

Remote Automation Solutions for IP-based Networks

Push-based Technology

- Event handling
- Bandwidth saving
- User-definable alarm messages



ioLogik W5300
Active GPRS Micro Controller
▶ see page 3



VPort 25
Outdoor IP Camera
▶ see page 14



EIP3000
Industrial Ethernet Gateway
▶ see page 19



AWK-6222
Dual-RF Wireless AP/Bridge/Client
▶ see page 22

What's Inside

GPRS Micro Controllers	3
Remote Ethernet I/O	5
Ethernet Micro Controllers	7
Peer-to-Peer I/O	10
Modular I/O	11
IP Surveillance	13
Device Networking	17
Ethernet Gateways	19
Ethernet Switches	21
Industrial Wireless	22

Complete and Reliable Solutions for Remote Automation

Modular Active Ethernet Micro Controller

The ioLogik E4200, featuring flexible, slim-type, and versatile I/O modules is suitable for remote monitoring and alarm applications that need more I/O points and a variety of I/O types, such as temperature sensors and water quality detectors.

Applications:

- Water treatment system monitoring
- Wastewater treatment system monitoring

▶ see page 11



Active Ethernet Micro Controllers

The ioLogik E2000 series delivers active, event-response based reporting and control of I/O devices to PC-based data acquisition and control. The I/O status of an Active Ethernet micro controller can be reported automatically based on user-specified conditions. The report-by-exception approach requires far less bandwidth than the traditional polling approach.

Applications:

- Pumping station monitoring
- Water tank monitoring

▶ see page 7

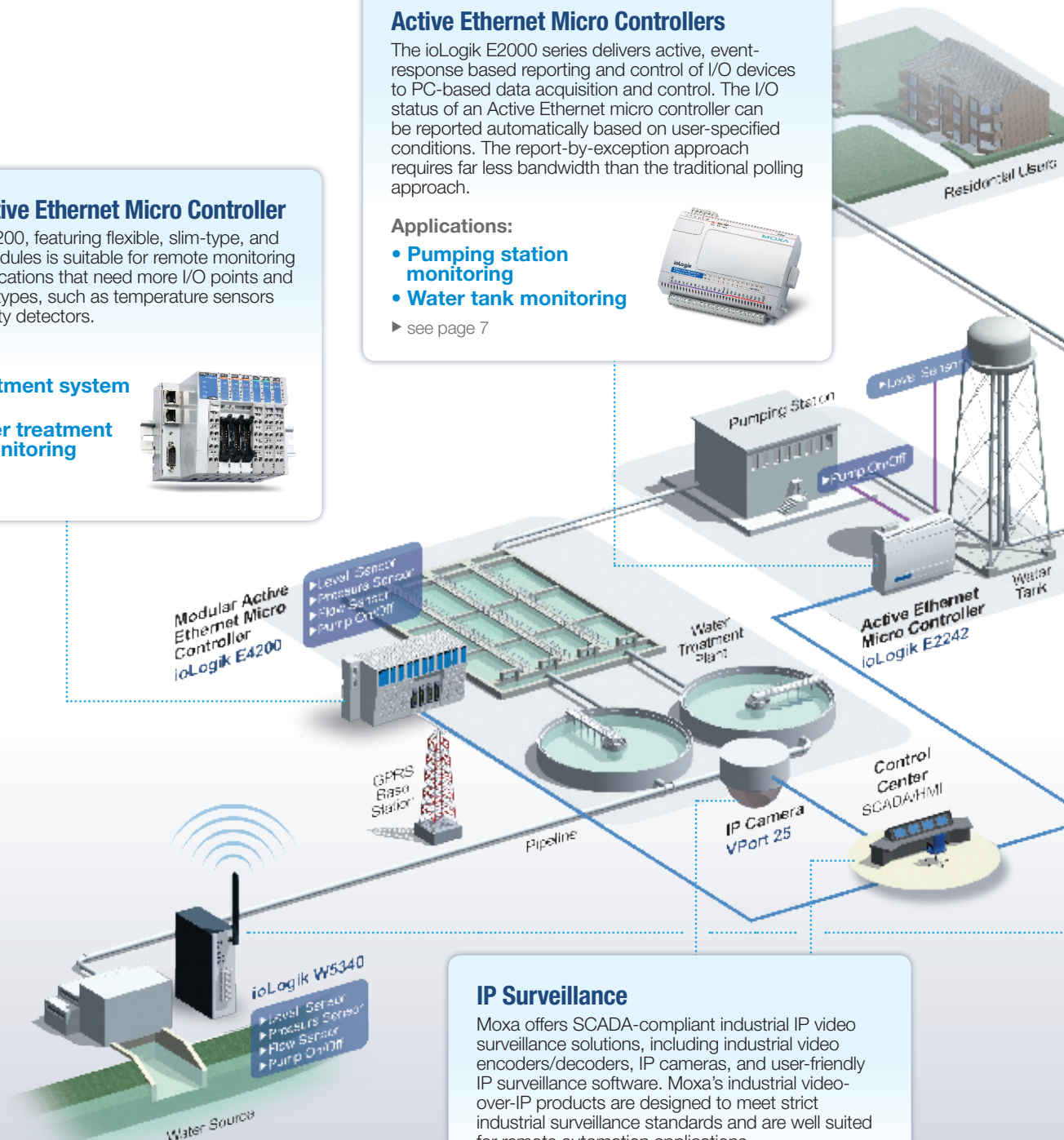

IP Surveillance

Moxa offers SCADA-compliant industrial IP video surveillance solutions, including industrial video encoders/decoders, IP cameras, and user-friendly IP surveillance software. Moxa's industrial video-over-IP products are designed to meet strict industrial surveillance standards and are well suited for remote automation applications.

Application:

- Water treatment system monitoring

▶ see page 13



Remote automation solutions are tailor-made for measurement and control applications at remote locations. Moxa provides a complete, highly integrated solution for field site data acquisition, IP surveillance, device networking, and communication infrastructures, which promises the highest operational reliability and communication efficiency for remote automation applications.

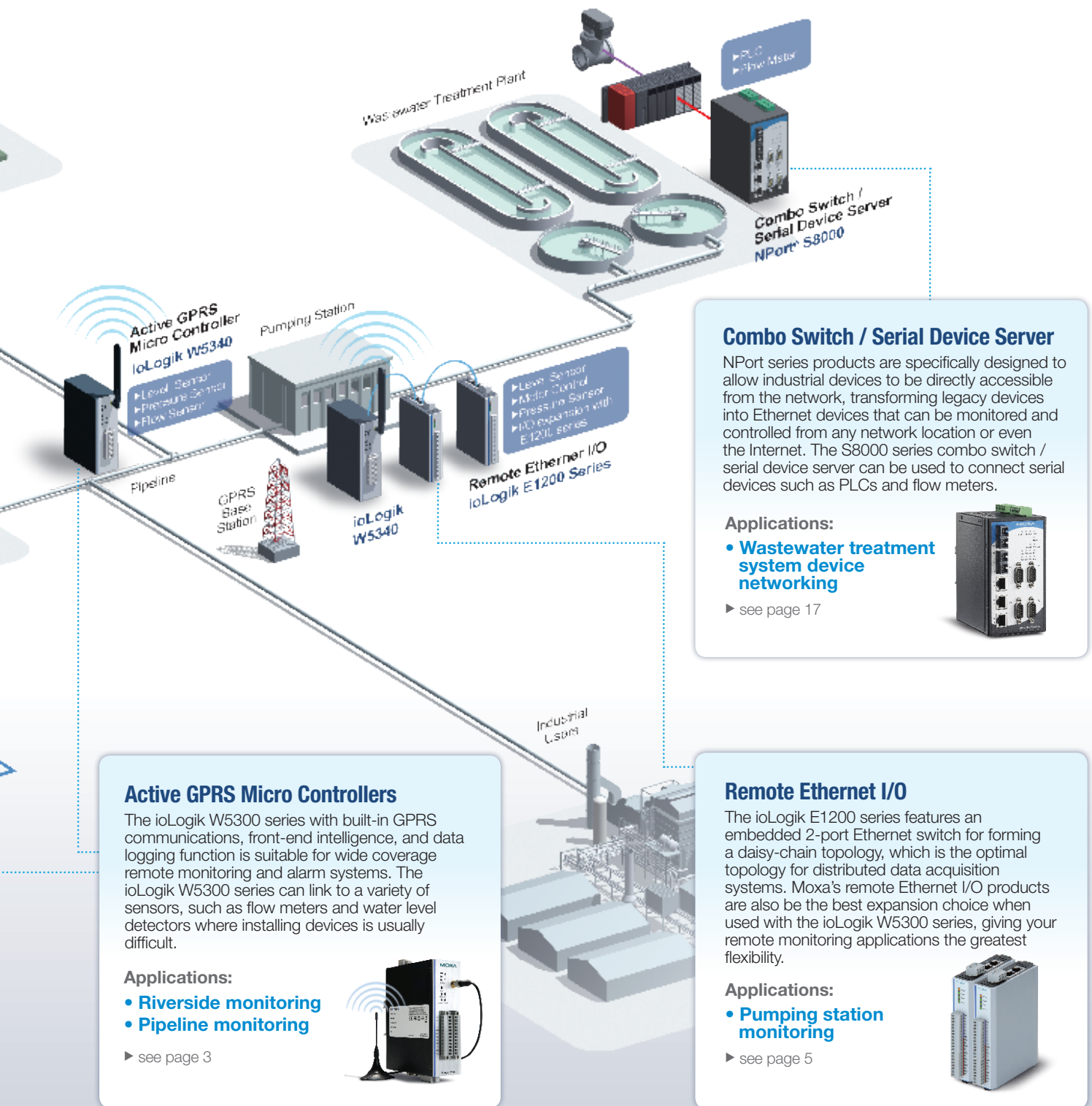

Combo Switch / Serial Device Server

NPort series products are specifically designed to allow industrial devices to be directly accessible from the network, transforming legacy devices into Ethernet devices that can be monitored and controlled from any network location or even the Internet. The S8000 series combo switch / serial device server can be used to connect serial devices such as PLCs and flow meters.

Applications:

- Wastewater treatment system device networking

▶ see page 17



Active GPRS Micro Controllers

The ioLogik W5300 series with built-in GPRS communications, front-end intelligence, and data logging function is suitable for wide coverage remote monitoring and alarm systems. The ioLogik W5300 series can link to a variety of sensors, such as flow meters and water level detectors where installing devices is usually difficult.

Applications:

- Riverside monitoring
- Pipeline monitoring

▶ see page 3



Remote Ethernet I/O

The ioLogik E1200 series features an embedded 2-port Ethernet switch for forming a daisy-chain topology, which is the optimal topology for distributed data acquisition systems. Moxa's remote Ethernet I/O products are also the best expansion choice when used with the ioLogik W5300 series, giving your remote monitoring applications the greatest flexibility.

Applications:

- Pumping station monitoring

▶ see page 5



Active GPRS Micro Controllers

All-in-One GPRS Remote Monitoring Solution

- Integrates a GPRS modem, I/O controller, and data logger
- Reduces operation cost and deployment time
- Supports Push-based Active OPC Server



All-in-one Compact Design

Reduce the total cost of system deployment with Moxa's new ioLogik W5300 series of GPRS micro controllers, which feature an all-in-one design that can completely replace multiple existing solutions for distributed telemetry over GPRS. ioLogik W5300 products combine the functions of a GPRS modem, I/O controller, and data logger, so you no longer need to buy or maintain separate devices. In addition, the ioLogik W5300's compact size makes installation simple and convenient.

Optimized Data Transmission Rate Saves on Communication Costs

In cellular communications, data transmission charges are based on the size of the transmitted data packets. The ioLogik W5300 comes with many features that optimize the data transmission rate and reduce your operating costs. Compared with the traditional "polling" structure, Moxa's "push-based" Active OPC Server conserves data transmission volume when communicating with SCADA systems. In addition, front-end data logging and report-by-exception functions minimize unnecessary data transmissions.



All-in-one Compact Solutions



Solve the Dynamic/Private IP Issue on GPRS Networks

The ioLogik W5300 series wireless micro controllers use Moxa's Active OPC Server as a central manager, which not only connects to the SCADA system, but also acts as a GPRS device gateway for managing the IP addresses of GPRS devices. Only the Active OPC Server requires a reachable, static IP. Remote ioLogik W5300 units can initiate communications actively to register their IP addresses with the GPRS gateway manager. The Active OPC Server uses an up-to-date IP-MAC lookup table to manage the remote W5300 units. Even if your remote devices are restricted to private/dynamic IPs, the Active OPC Server can still know how many devices are on line and what their IP addresses are.

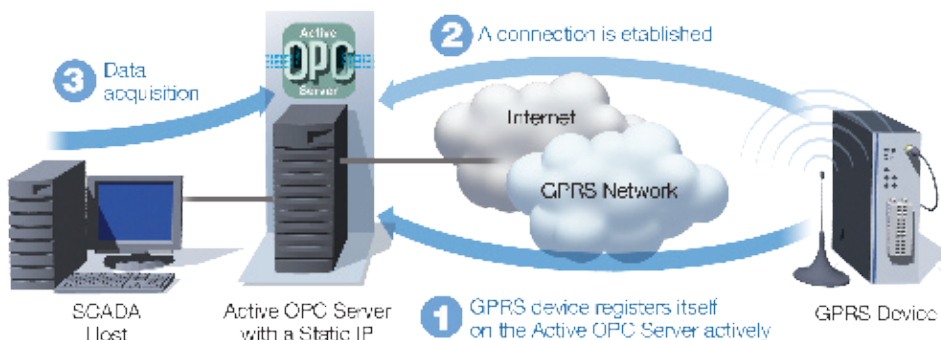

ioLogik W5300 Series Active Cellular Micro Controllers

- Integrated, compact all-in-one solution for cellular telemetry applications
- Definable cellular connection strategy to optimize data transmission
- Intuitive menu driven front-end intelligence
- Flexible unicode alarm system supporting SMS, email, SNMP Trap, and TCP/UDP
- One RS-232/422/485 serial port built in to connect with field serial devices

Wide temperature models and HSDPA (3.5G) models available!



Active OPC Server Lite *Free Download!*

Seamlessly Connect ioLogik to your SCADA Systems

Active OPC Server Lite is a software package that operates as an OPC driver for an HMI or SCADA system. It offers seamless connection from ioLogik products to SCADA systems, including Wonderware, Citect, and iFix. Active OPC Server Lite meets the OPC DA 3.0 standard, which allows connections to various kinds of devices and host OPC machines.

- OPC DA 3.0 supported
- Event-driven tag update
- Save 80% on network bandwidth
- I/O response that's 7 times faster
- Patented automatic tag generation
- Firewall-friendly connection from remote ioLogik devices



Smart I/O Connection Migrating from "Pull" to "Push"

General OPC servers typically use the "pull" architecture to connect to Ethernet I/O devices, which involves an HMI/SCADA system continuously sending out commands to collect relevant data. Active OPC Server supports the standard OPC protocol, but also offers active (or "push") communication with the ioLogik series of Active Ethernet micro controllers to HMI/SCADA systems, providing instant I/O status reports.

7 Times Faster I/O Response and 80% off Bandwidth Usage with Event-driven Tag Update

Active OPC Server Lite and the ioLogik series support "Auto Tag Generation," which eliminates the headache of specifying target IP addresses, I/O channels, and data formats one by one, or editing and importing configuration text files. Active tags automatically created by the Active OPC Server Lite and the ioLogik report the I/O status only when it changes. This event-driven tag status update makes the I/O response 7 times faster than 3rd party OPC Server packages in a test of 2,560 I/O channels. In another test of network bandwidth usage, Active OPC Server Lite and the ioLogik reduced traffic by 80%.

- Active OPC Server reduces network traffic by at least 50%
- Upgrade your HMI/SCADA system with a brand-new Active architecture

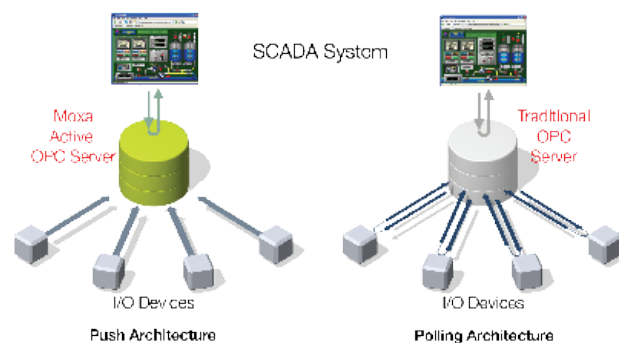

Test I: Network Traffic Comparison

This test used 32 ioLogik E2210 units with 640 DI/O points. As shown in the figure, Active Ethernet micro controllers can save 80% on bandwidth consumption compared to passive Ethernet I/O.



Test II: Response Time for I/O Status

This test used 128 ioLogik E2210 units with 2,560 I/O points. As shown in the figure, the active architecture is 7 times faster than the passive architecture in response time when the I/O status changes.

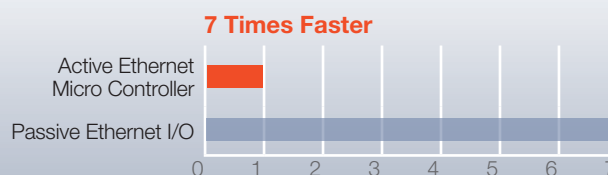

Remote Ethernet I/O

Daisy-chain Topology Reduces Wiring Costs

- Two embedded Ethernet switch ports
- Reduces wiring costs and effort
- Push-based Active OPC Server
- User-defined Modbus/TCP addressing



Daisy-chain Topology Simplifies Cabling and Reduces Deployment Costs

Save costs and eliminate cabling hassles with Moxa's ioLogik E1200 remote Ethernet I/O products. Thanks to two embedded Ethernet switch ports, this innovative design allows you to create daisy-chain topologies for flexible device cabling. In a distributed Ethernet data acquisition application, panels, units, and cabinets are often located at remote sites with limited space. Daisy-chaining ioLogik E1200 units to each other or other nearby Ethernet devices not only saves space, it reduces cabling, deployment time, and work requirements significantly. Applications such as factory automation, security and surveillance systems, and tunnel monitoring can all benefit from the ioLogik E1200 series' daisy-chain connection capability.

Push-based Active OPC Server for Seamless Connections to SCADA Systems

Use active communications to achieve faster response time with lower network bandwidth consumption in SCADA systems. Moxa's Active OPC Server Lite is a free software package that operates as an OPC driver for HMI/SCADA systems. Conventional OPC servers typically use a polling method to connect to Ethernet I/O devices, which continuously sends commands to collect the relevant data. Moxa's Active OPC Server Lite offers active, or "push" communications from Moxa's ioLogik Ethernet I/O products to HMI/SCADA systems, providing instant I/O status reports by using "Active Tags."

User-defined Modbus/TCP Addressing for Painless Upgrades of Existing Systems

For Modbus devices that are controlled and detected by fixed addresses and functions, users need to spend time to research and verify the configuration information in the manual. For each device you need to find detailed information on the respective I/O channel and verify that the addresses defined by vendors meet the requirements, such as the initial address or start address of a SCADA system or a PLC controller. With user-defined Modbus/TCP addressing, the ioLogik E1200 offers greater flexibility and ease of setup. Instead of worrying about the definition, you can simply configure the function and address map to directly fit your desired system.



Star vs. Daisy-chain Topology

Compared with star topologies, daisy-chain topologies offer the following benefits:

- Flexible cabling
- Save space, deployment time, and labor costs
- Easy expansion

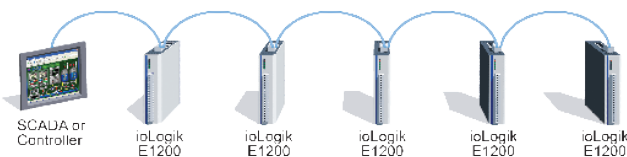

Daisy-chain Topology

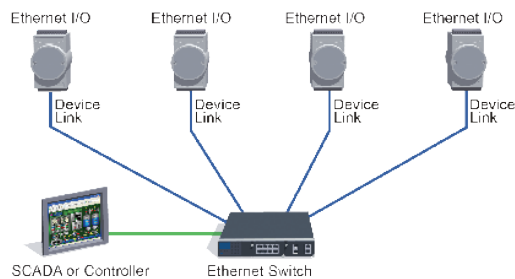

Star Topology

ioLogik E1200 Series Remote Ethernet I/O with 2-port Ethernet Switch

- Built-in 2-port Ethernet switch for daisy-chain topology
- Free support of Moxa's Active OPC Server Lite for seamless connections to SCADA systems
- User-defined Modbus/TCP addressing
- MXIO programming library for Windows/WinCE VB/VC.NET and Linux C APIs
- Web configuration with Import/Export function



Temperature Monitoring System in a Remote Gas Pipeline Tunnel

Monitoring the temperature of a gas pipeline tunnel is crucial for safe operations. Confined tunnels present a unique challenge since the temperature can rise easily and overheating could cause pipeline fractures that lead to gas leaks or even explosions. As a consequence of the long and narrow dimensions inherent in a tunnel layout, cabling costs can increase since more home run cables must be installed to link all of the temperature gauge data acquisition I/O devices back to the pipeline's SCADA system. Moxa's ioLogik E1240 remote Ethernet I/O with 8 AIs and two switch ports can be used to daisy-chain one E1240 to another, reducing wiring costs. Moreover, the ioLogik E1240 supports Active OPC Server, which allows real-time temperature updates to be sent to the SCADA system.

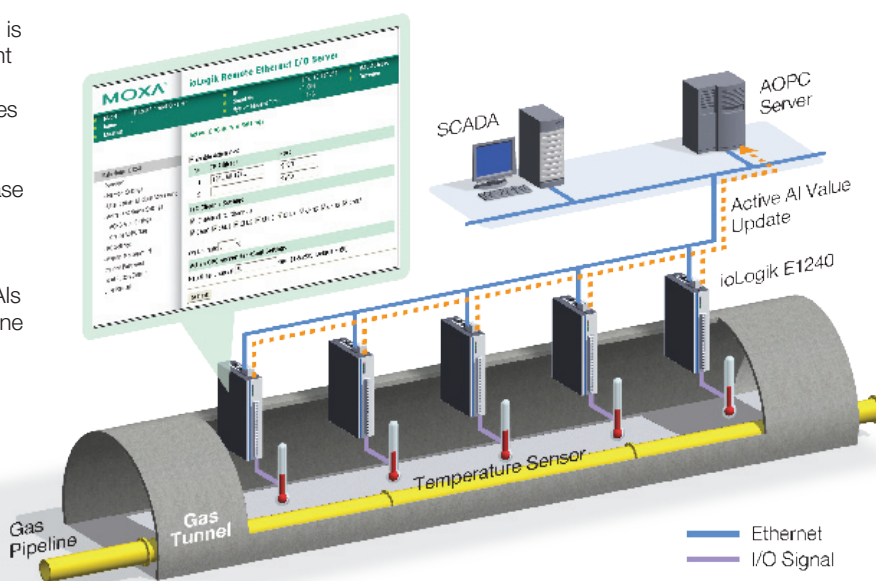

Remote Ethernet I/O Selection Table

Model \ I/O	I/O Combinations							
	Digital Inputs	Digital Outputs	Analog Inputs	Analog Outputs	RTD Inputs	TC Inputs	Relay Outputs	Configurable DIOs
ioLogik E1210	16	–	–	–	–	–	–	–
ioLogik E1211	–	16	–	–	–	–	–	–
ioLogik E1212	8	–	–	–	–	–	–	8
ioLogik E1214	6	–	–	–	–	–	6	–
ioLogik E1240	–	–	8	–	–	–	–	–
ioLogik E1241	–	–	–	4	–	–	–	–
ioLogik E1242	4	–	4	–	–	–	–	4
ioLogik E1260	–	–	–	–	6	–	–	–
ioLogik E1262	–	–	–	–	–	8	–	–

* Single LAN and wide temperature (-40 to 75°C) models are available per request.

Active Ethernet Micro Controllers

Transform Your Remote Monitoring and Alarm Systems from Passive to Active

- Push-based alarm messaging by TCP/UDP/email/SNMP-trap
- Supports SNMP v1, v2c, and v3
- Supports easy-to-use Click&Go™ logic for local control



Event-based Reporting with Innovative Push Technology

Moxa's Active Ethernet micro controllers deliver active, event-response based reporting and control of I/O devices to the PC-based data acquisition and control field. Active Ethernet micro controllers report I/O status automatically based on user-specified conditions. This report-by-exception approach requires far less bandwidth than the traditional polling approach. Critical sensor data can be obtained immediately with a real-time stamp instead of being confined to specific points of time, making Moxa's Active Ethernet micro controller the best choice for remote monitoring and alarm applications.

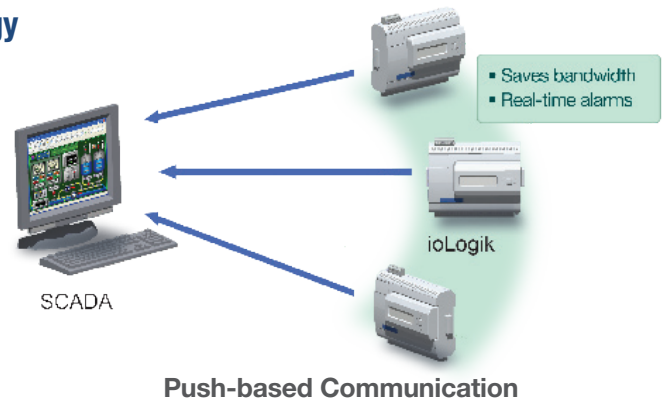

Use SNMP Protocol to Manage All Devices over Ethernet

Since Ethernet networks are already being used by many facilities, a data acquisition system composed of Ethernet devices is cost-effective and easy to implement. Moxa's Active Ethernet micro controllers are SNMP compatible, making them easy to integrate with existing SNMP-enabled software to simplify your remote monitoring system. You can easily manage all of your Ethernet devices, such as switches, routers, and I/O servers to obtain all of your environmental parameters.

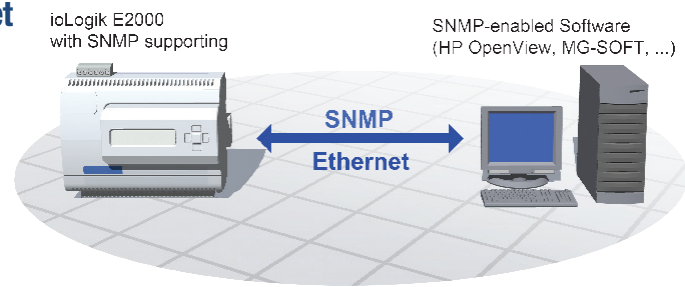

Active Ethernet Micro Controller vs. Traditional Remote I/O

	Active Ethernet Micro Controller 	Remote I/O
Protocols	Modbus for IA engineers SNMP/TCP/UDP/e-mail /CGI Commands for IT engineers	Modbus
Communication Architecture	Supports push and pull architecture (Push technology uses TCP, UDP, SNMP trap, email, and Active OPC Server)	Pull
Local Control Capability	<ul style="list-style-type: none"> • Click&Go™ logic • No programming effort required • Menu driven 	N/A
Interface	Ethernet/GPRS	Ethernet
Solution	Standalone solution	PLC components

Digital I/O Modules

ioLogik E2210 (12 DIs, 8 DOs)

- DI or counter mode supported
- Dry contact or wet contact (NPN) DO or pulse output

Digital I/O

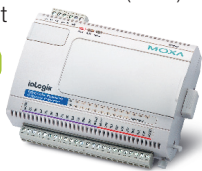

ioLogik E2212 (8 DIs, 8 DOs, 4 DIOs)

- Software configurable DI or DO channels
- Dry contact or wet contact (PNP/NPN) supported

Configurable



ioLogik E2214 (6 DIs, 6 Relays)

- 6 Form A relays
- Relay: 5A/250 VAC or 5A/30 VDC
- Relay counter for relay usage monitor

Relay

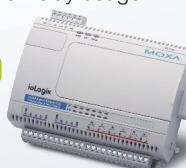

Versatile I/O Combinations for a Variety of Applications

Ease of Use

- Programming-free IF-THEN-ELSE control logic
- Menu-driven configuration interface
- Web console

Ease of Integration

- DLL Library SDK
- Active OPC Server, no OPC tag creation needed
- CGI command for web-based SCADA

Versatile Communication Methods

- TCP/UDP
- CGI command
- eMail
- SNMP trap

Push Technology

- I/O event report by exception
- Built-in RTC to provide precise timestamps for alarm messages
- Save 80% of your bandwidth
- 7-fold increase in response time

Analog I/O Modules

ioLogik E2240 (8 AIs, 2 AOs)

- ± 150 mV, ± 500 mV, ± 5 V, ± 10 V, 0 to 20 mA, 4 to 20 mA
- Adjustable sampling rate
- AI to AO signal replication over IP

Analog I/O



ioLogik E2242 (4 AIs, 12 DIOs)

- Software configurable DI or DO channels
- ± 150 mV, 0 to 150 mV, ± 500 mV, 0 to 500 mV, ± 5 V, 0 to 5 V, ± 10 V, 0 to 10 V, 0 to 20 mA, 4 to 20 mA
- Adjustable sampling rate
- Wide temperature (-40 to 75°C) model available

Mixed I/O



Temperature Modules

ioLogik E2260 (6 RTDs, 4 DOs)

- PT, JPT, Ni, and RTD sensors supported
- Built-in sensor temperature mapping tables
- 16-bit resolution

RTD



TC

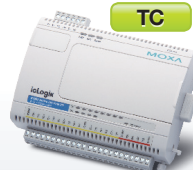

ioLogik E2262 (8 TC inputs, 4 DOs)

- Supports J, K, T, E, R, S, B, N type TC and mV
- Built-in sensor temperature mapping tables
- 16-bit resolution



SNMPv3 for Secure Private Communications

Moxa's Active Ethernet micro controllers are the first I/O products to support SNMPv3. SNMPv3 support is important because it provides powerful security features for protecting your network communications from unauthorized access. The security features include message integrity to verify that packet contents have not been altered, authentication to verify that packets come from an authorized source, and encryption to ensure that packets intercepted by unauthorized machines are unreadable.



ioLogik E2000 Series

Click&Go™ — The Most Powerful and Intelligent I/O Control Logic



- Easy and intuitive IF-THEN-ELSE style control logic
- PC-free solution with local intelligence
- Active alarm reports with TCP/UDP/SNMP-trap/email/SMS/CGI commands
- Peer-to-peer function

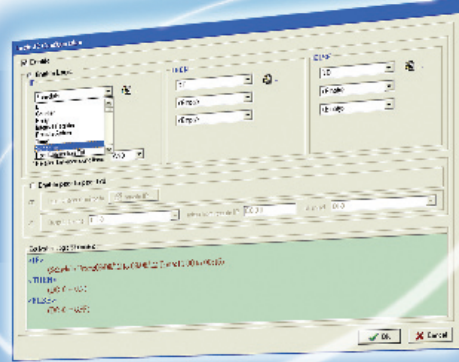

Front-end Intelligence for Smarter I/O Control

Moxa's patented Click&Go™ control logic bridges the gap between information technology and industrial automation. With this intuitive IF-THEN-ELSE style control logic, configuration is the only thing you'll need to learn. Unlike traditional C-language or PLC ladder logic, even an untrained user can learn how to perform I/O configurations in just a few minutes. Click&Go™ supports many powerful functions that make Moxa's ioLogik E2000, W5300, and E4200 series even more intelligent.

Making Device Control Easy

Remote Action

Programmers sometimes need to trigger remote digital output based on local analog values. In the example shown here, a water level sensor was installed in a water tower. When the water level drops below a preset level, the analog signal from the sensor will be converted to a remote digital output, which triggers the pump to turn on. Although this is a relatively simple example, Click&Go™ can handle different set points and trigger conditions.

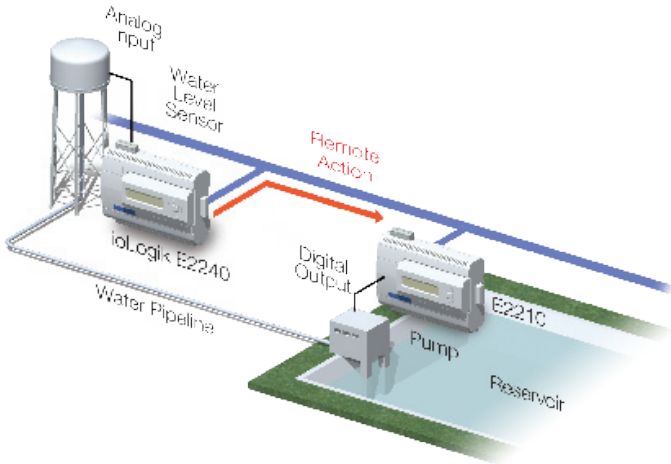

CGI Commands

CGI commands are based on the HTTP protocol, which is the most popular protocol for accessing the Internet. Users will be able to access Moxa's micro controllers from anywhere with a simple web browser, and can even communicate through firewalls. Software developers can use CGI commands to integrate I/O functions into their software, which is often used with IP surveillance systems. Moxa's Active Ethernet micro controllers can both send and receive CGI commands, and for this reason are compatible with surveillance devices that support CGI commands.

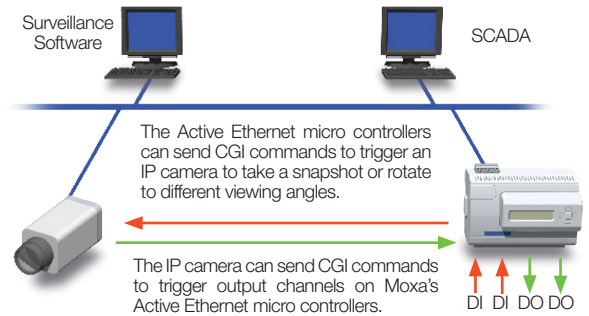

Active Reporting for Real-time Monitoring

Click&Go™ is designed to provide a simple configuration platform and real-time monitoring capability. For any alarm system, fast response and real-time monitoring is very important. Click&Go™ supports various active communication methods, including TCP, UDP, SNMP Trap, email, and CGI commands, making it very easy to integrate Click&Go™ with any monitoring system. Click&Go™ also supports SNTP for time alignment, making sequential and historical alarm tracking possible. In addition, users can define the content of alarm messages themselves, making Click&Go™ a perfect solution for system users.

Advanced Functions Supported by Active Micro Controllers

Click&Go™

Active OPC Server

SNMP



ioLogik E2000 Series



ioLogik E4200



ioLogik W5300 Series

Peer-to-Peer I/O

Simplify Input to Output Connections in your Existing IP Infrastructures

- Reduced cabling costs
- Easy I/O configuration
- Flexible deployment options: Ethernet, fiber, and wireless

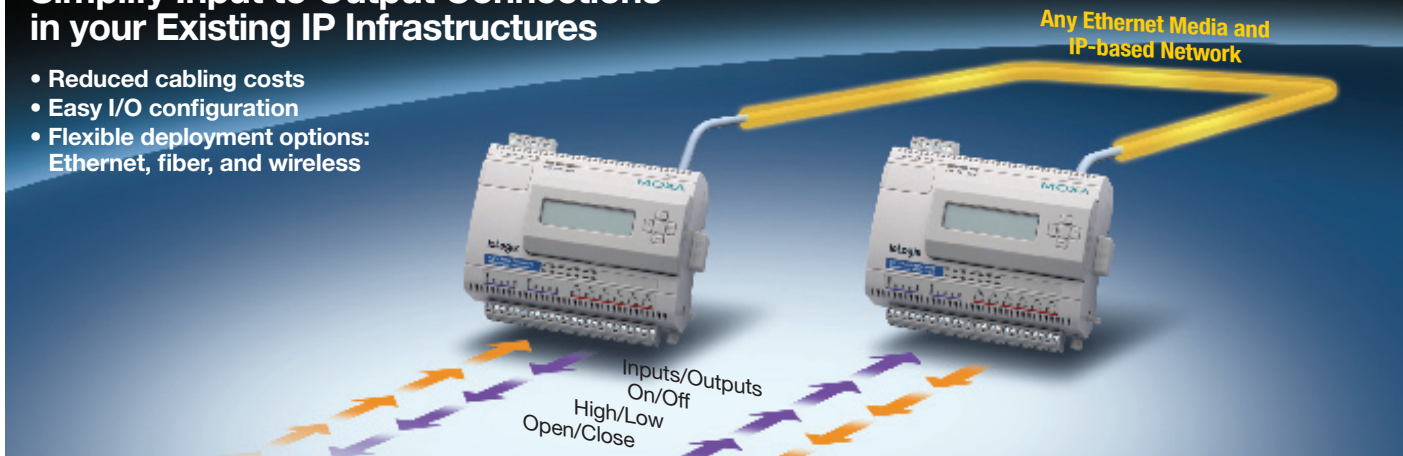

Take Advantage of Existing IP Infrastructure

The easiest and fastest way to connect input signals to remote outputs is to connect them over Ethernet and IP networks with ioMirror peer-to-peer I/O products. With the ioMirror E3210, you can transmit signals unlimited distances without any programming or a separate controller. The ioMirror E3210 works with Ethernet LANs via RJ45, fiber optic, or wireless connections. General input and output signals can be connected through the existing IP-based network infrastructure using a pair of ioMirror E3210s, making wiring simpler than ever.

Deliver the Signal to Your Dashboard within 20 ms

Moxa's ioMirror E3000 products use peer-to-peer technology to communicate with each other. The peer-to-peer function is the easiest and fastest way to connect input signals to remote outputs by connecting them over Ethernet and IP networks. With ioMirror products, signals can be transmitted over unlimited distances without any programming or a separate controller. Response time is within 20 ms.

Simple Web Console Configuration

Unlike PLC or PC solutions, ioMirror I/O products do not require any complex configurations or programming. You can configure signal mapping automatically through the built-in Web console to extend your Ethernet network to cover remote input signals.

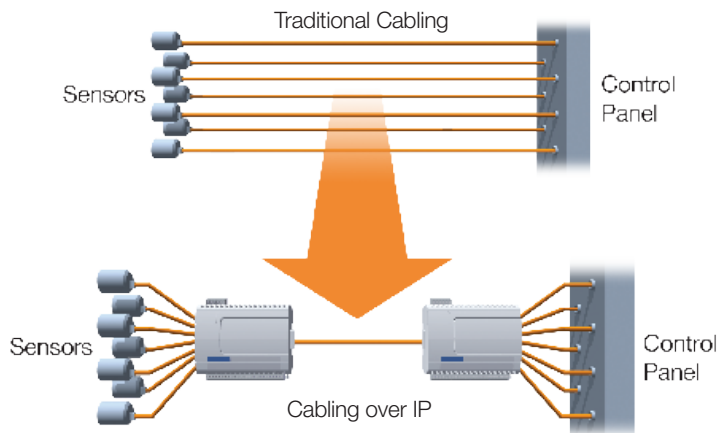
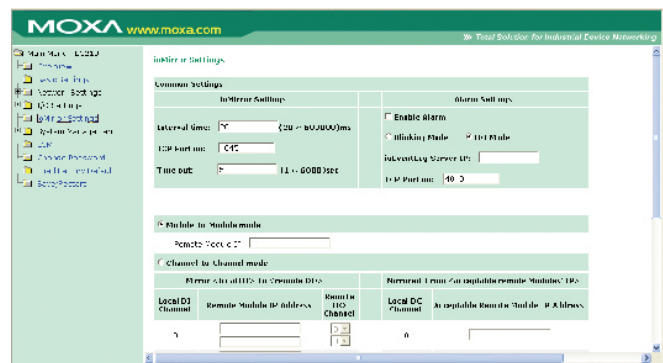

ioMirror E3210 Peer-to-Peer I/O

- Direct input-to-output signal communication over IP
- High speed Peer-to-Peer I/O within 20 ms
- One physical alarm port for connectivity status
- Quick and easy utility and web-based settings
- Local alarm channel



Modular Controller and I/O

Create a Compact Data Acquisition and Alarm System

- Variety of network adaptors and I/O options
- Slice-type system composition saves cabinet space
- Rich communication and control protocols
- Easy-to-use alarm function with e-mail, SMS, and SNMP trap



Mix and Match a Modular Solution in Just 3 Steps

Always adding more channels to your remote controller or remote I/O? Moxa's modular controller and I/O systems are perfect for large scale remote monitoring and alarm systems with special requirements, such as those used in water treatment and supply systems, factory power monitoring systems, and machinery. These applications need more I/O ports and a variety of I/O types to accommodate a specific array of devices, including temperature sensors, gas detectors, and water quality detectors. The ioLogik E4200 and ioLogik 4000 series come with a versatile mixture of I/O features that can be customized to fit any application.

Step 1 Select a network adaptor

Modular Active Ethernet Micro Controller — ioLogik E4200

- Intelligent micro controller with Click&Go™ local control logic
- Dual Ethernet LANs and 1 RS-232 for SMS alarm
- Supports up to 16 modules
- Supports Active OPC Server, Modbus/TCP, SNMP, and MXIO Library for remote I/O control
- Time stamped E-mail, SMS, and TCP/DUP alarm messages



- ✓ Dual Ethernet
- ✓ Click&Go™
- ✓ Active OPC Server

Modular Ethernet and RS-232/485 Network Adaptors — NA-4010/4020/4021

- Supports up to 32 modules
- Supports Modbus/TCP, Modbus/RTU, and MXIO Library for remote I/O Control



- ✓ Ethernet
- ✓ Modbus/TCP

NA-4010: Modular Ethernet Adaptor



- ✓ RS-232/485
- ✓ Modbus/TCP

NA-4020: Modular RS-485 Adaptor
NA-4021: Modular RS-232 Adaptor

Step 2 Select I/O modules



		DC-Digital Inputs				AC-Digital Inputs	
Specs	Model	M-1800	M-1801	M-1600	M-1601	M-1450	M-1451
	Channels	8	8	16	16	4	4
	Sink/Source	Sink	Source	Sink	Source	-	-
	Connector	RTB	RTB	20-pin	20-pin	RTB	RTB
	Voltage	24 VDC	24 VDC	24 VDC	24 VDC	110 VAC	220 VAC
	Isolation	Optical isolation					



		Digital Outputs				
Specs	Model	M-2800	M-2801	M-2600	M-2601	M-2450
	Channels	8	8	16	16	4
	Sink/Source	Sink	Source	Sink	Source	Relay
	Connector	RTB	RTB	20-pin	20-pin	RTB
	Voltage	24 VDC	24 VDC	24 VDC	24 VDC	24 VDC
	Current	0.5 A	0.5 A	0.3 A	0.3 A	2.0 A
Isolation	Optical isolation					



		Analog Inputs			
Specs	Model	M-3802	M-3810	M-6200	M-6201
	Channels	8	8	2	2
	Current	4 to 20 mA	-	-	-
	Voltage	-	0 to 10 V	-	-
	Connector	RTB	RTB	RTB	RTB
	Resolution	12-bit	12-bit	-	-
	Isolation	Optical isolation			
	Sensor Input	-	-	RTD (ohms)	Thermo-couple (mV)



		Analog Outputs	
Specs	Model	M-4402	M-4410
	Channels	4	4
	Current	4 to 20 mA	-
	Voltage	-	0 to 10 V
	Connector	RTB	RTB
	Resolution	12-bit	12-bit
Isolation	Optical isolation		

Step 3 Select power modules (optional)

		Power Modules			
Specs	Model	M-7001	M-7002	M-7804	M-7805
	Channels	0	0	8	8
	Voltage	24 VDC	DC: 5, 24, 48 VDC AC: 110/220 VAC	0 VDC	24 VDC
	Purpose	System Power	Field Power	Field Power	-



How do I send SMS alarms?

Step 1. Connect the ioLogik to a GSM modem

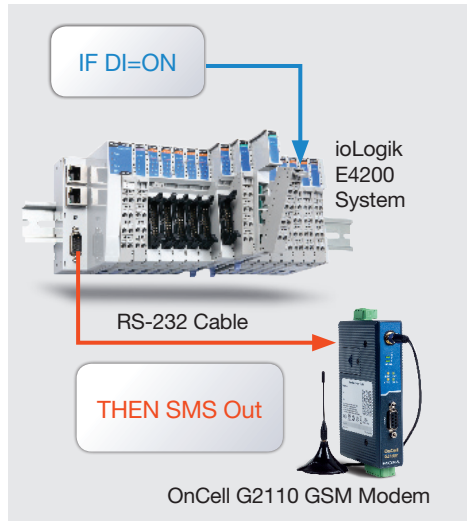

Step 2. Configure Click&Go™ logic

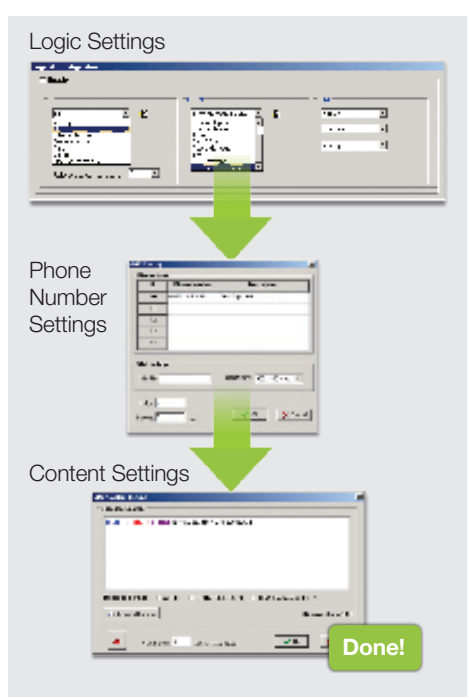

Industrial Video Servers and Cameras

H.264 Industrial IP Video Encoders

- H.264 and MJPEG supported
- 3 simultaneous video streams
- Latency under 200 ms



VPort 461 H.264 Industrial Video Encoder

Optimized IP Video Performance

The VPort 461 is a 1-channel industrial IP video encoder that transforms analog video into three simultaneous video streams in H.264 and MJPEG formats with low latency. Regardless of whether you use an H.264 or MJPEG video stream, the VPort 461 assures optimized video performance for live video monitoring, recording, image analysis, and event triggering over Ethernet.

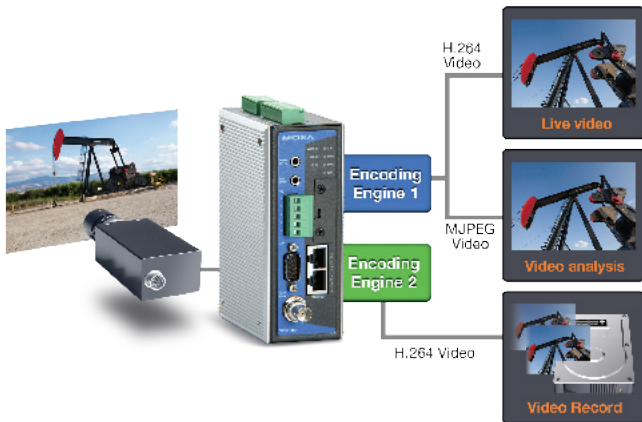

Low Latency Ensures Real-time Security

The VPort 461 ensures an end-to-end transmission latency of under 200 ms. Such a low latency guarantees that VPort 461 users can operate a camera's pan-tilt-zoom control to capture images from any web browser for critical, real-time security.

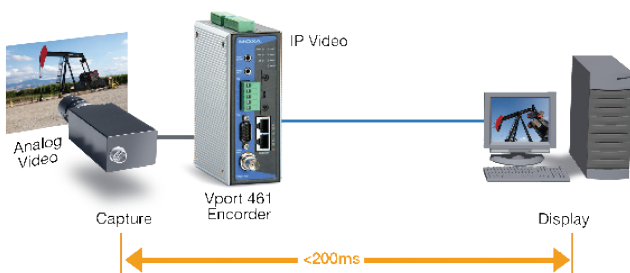

Two Ethernet Ports for Cascading or Port Redundancy

The VPort 461 has two built-in 10/100 Mbps Ethernet ports for cascading multiple network devices. With the cascade feature, fewer switch ports are needed, and you also save on cabling costs and effort when setting up your system. Alternatively, the same Ethernet ports can be used to set up a backup path to continue transmitting video when the primary path is disconnected.

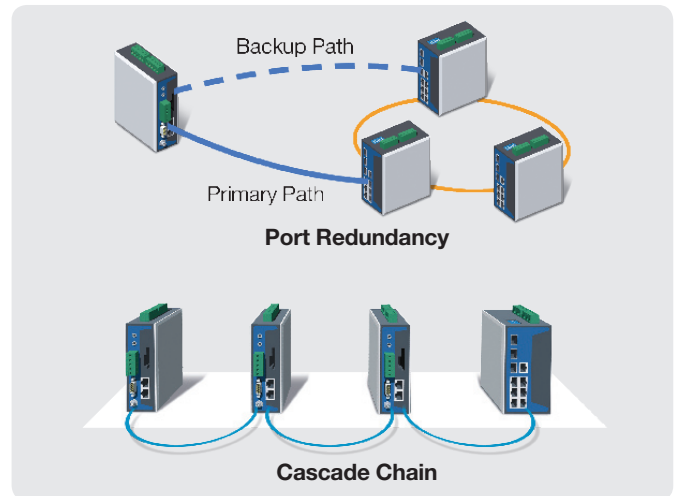

VPort 461 Series 1-channel H.264/MJPEG Industrial Video Encoders

- Dual codec for H.264 and MJPEG
- 3 simultaneous video streams
- Video latency under 200 ms
- SD/SDHC supported
- 2-way audio
- -40 to 75°C operating temperature
- 2 Ethernet ports for cascade or port redundancy
- Modbus/TCP supported
- Free VPort SDK PLUS development kit

Why Use Moxa VPort Solutions?

Industrial Grade Reliability for Extreme Environments

Moxa's IP video products are designed with numerous heavy-duty features, adhere to strict industry approvals, and are sure to solve any harsh application challenge that you encounter. The complete range from industrial video servers, IP cameras, and surveillance applications, to software development kit help our customers build up a hassle-free IP video surveillance.

- -40 to 75°C operating temperature
- Redundant power inputs
- EMI and surge protection
- IP30/66 rated enclosure
- High MTBF (> 150,000 hrs)
- DIN-Rail and panel mounting
- Industry approvals: UL508, C1D2/ATEX Z2, DNV, and NEMA TS2

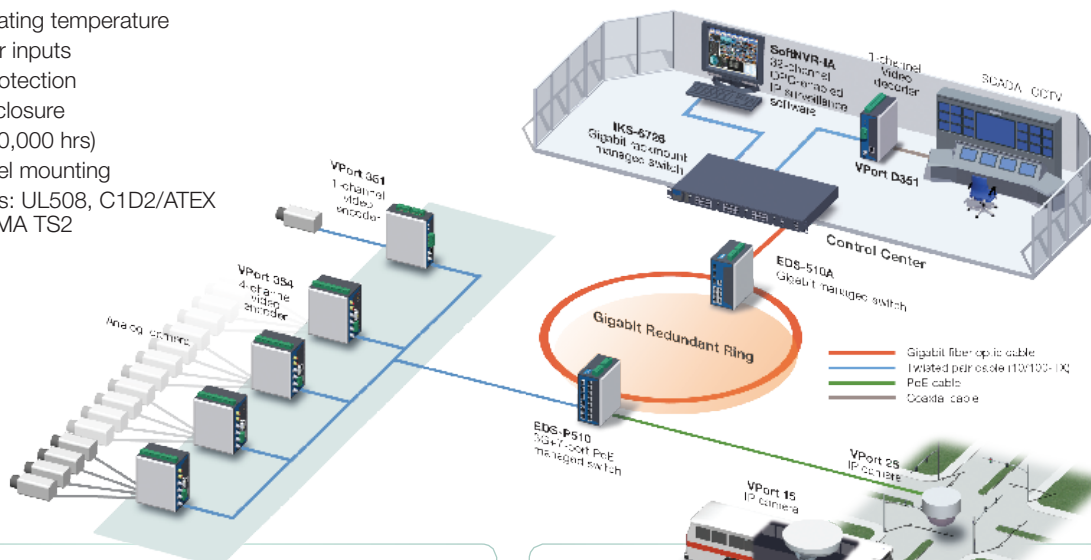

Full Spectrum of MJPEG/MPEG4 IP Video Servers

VPort 354 Series

Full Motion, 4-channel MJPEG/MPEG4 Industrial Video Encoders



- Video stream up to 120 FPS at 4CIF (704 x 480)
- 2-way (1 in, 1 out) audio supported
- -34 to 74°C operating temperature
- RJ45 or fiber Ethernet ports
- 2 Ethernet ports for cascade and port redundancy
- SD card slot for local storage capability
- Modbus communication with SCADA

VPort 254 Series

4-channel MJPEG/MPEG4 Industrial Video Encoders



- Video stream up to 120 FPS at CIF (352 x 240)
- -40 to 75°C operating temperature
- Fiber optic Ethernet port supported
- Modbus communication with SCADA
- CE/FCC, UL508 certified

VPort 351 Series

Full Motion, 1-channel MJPEG/MPEG4 Industrial Video Encoders



- Video stream up to 30 FPS at full D1 (720 x 480)
- Pre/post-alarm video recording
- 2-way (1 in, 1 out) audio supported
- -40 to 75°C operating temperature
- Fiber optic Ethernet port
- UL/cUL Class I, Division 2, DNV certified

VPort D351

1-channel MJPEG/MPEG4 Industrial Video Decoder



- Manual selection or automatic scan with max. of 64 video sources
- 2-way (1 in, 1 out) audio supported
- Transparent control with legacy PTZ controller
- CE/FCC, UL508 certified

Rugged Outdoor IP Cameras

Moxa VPort series fixed dome IP cameras feature IP66 rated protection and an extended operating temperature for use in harsh environments. The VPort 15-M12 complies with EN50155 standards for rolling stock, and the VPort 25 incorporates a day-and-night lens with up to 520 TVL and Sony high-resolution CCD sensor. This combination of features make the VPort IP camera series a top choice for both indoor and outdoor applications.

VPort 15 Series

EN50155 Compliance, 1.3-megapixel, Compact Fixed Dome IP Cameras



- 1.3 megapixel resolution
- EN50155 compliant for rolling stock applications
- Simultaneous MJPEG and MJPEG dual video streams
- IEEE 802.3af PoE supported for less cabling and easy installation
- M12 Ethernet connectors for high vibration environments
- -25 to 55°C wide operating temperature
- IP66-rated protection
- Free VPort SDK PLUS development kit

VPort 25 Series

IP66, Day-and-night Vandal-proof Fixed Dome IP Cameras



- -40 to 50°C operating temperature
- IP66-rated protection
- Direct-wired power input and PoE for power redundancy
- Up to 30 FPS at 720 x 480
- One camera lens for day and night use

Industrial IP Surveillance Software Solutions

32-channel IP Video Surveillance Software

Designed for Industrial Automation Systems

- Built-in OPC server
- Live-view GUI and video pop-up for SCADA/HMI
- Intelligent event handling
- Dual monitor display



SoftNVR-IA Enables OPC Communications between IP Surveillance and Automation Systems

SoftNVR-IA is an industrial network video recording software designed for Moxa IP video servers and cameras. SoftNVR-IA features a built-in OPC server that enables direct communications between factory floor automation systems, such as HMI/SCADA systems, and Moxa's IP-based network video products. It provides unlimited capability to integrate IP surveillance systems with automation systems for the industrial system integrator.

- Up to 32 channels in one system
- Built-in OPC server for easy communication with automation systems
- Live view with H.264, MPEG4, and MJPEG from the VPort series
- Dual monitor display capability
- Video recording with manual control, event-trigger, and schedule setting
- Playback system with search by event and time
- Supports English, Traditional Chinese, and Simplified Chinese

Visual Management in Automation Systems

The fact that advanced automation systems require a higher degree of management and control was a major motivation for Moxa's development of IP-based visual management for industrial automation systems. Moxa's visual management solution integrates IP video networking and industrial automation systems to facilitate real-time visualization, giving system administrators faster and more relevant responses to enhance event management.

3-layer Architecture for Easy Integration

Automation systems are often described as consisting of three layers: the information layer, the control layer, and the device layer. Moxa has developed a similar structure for IP surveillance solutions, which can be described as consisting of the management layer, the operation layer, and the device layer.

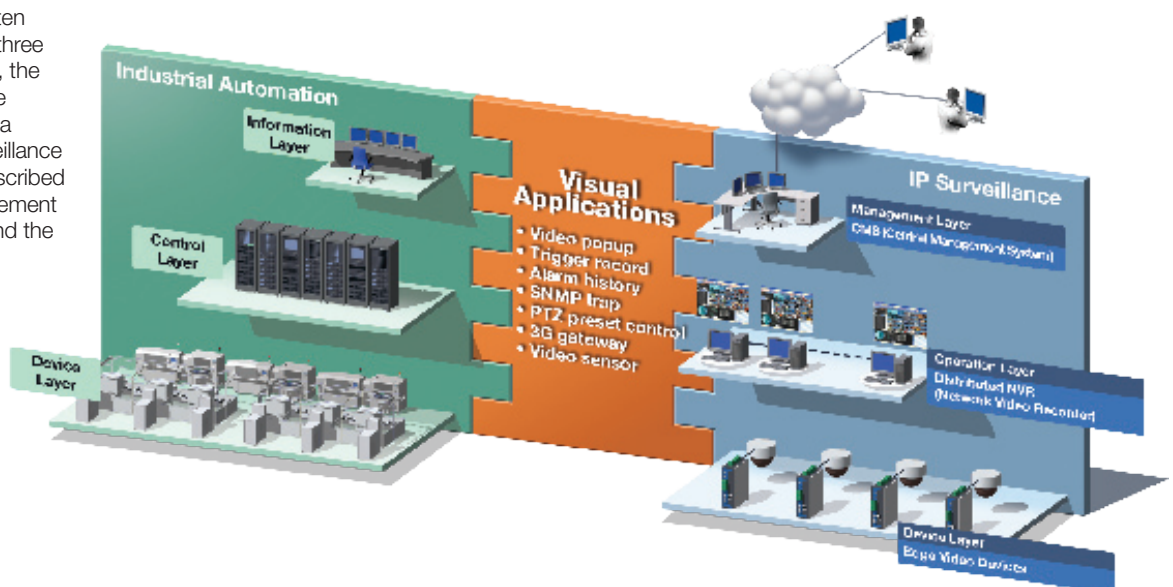



IA or IT? Do you need to run both systems to check your event status? Moxa's IP Surveillance Solution Makes SCADA Visual Monitoring Easier and More Efficient

Moxa's industrial IP surveillance solutions integrate excellent video quality, an industrial-grade rugged design, and powerful networking capability to give users a hassle-free IP video surveillance solution tailored to their own unique requirements. The full range of VPort series IP cameras and video servers support Modbus/TCP, which can be used to communicate directly with most SCADA automation systems. In addition, the SoftNVR-IA IP surveillance software, the VPort SDK PLUS software development kit, and VPort Video Gadget (a coding free software development tool for SCADA software) provide an OPC communication and ActiveX Control component for SCADA automation systems, making Moxa's IP surveillance solution ideal for industrial facility surveillance.



VPort SDK Plus

Free Software Development Kit for Third-party Software Developers and System Integrators

VPort SDK PLUS is bundled free with VPort products to help customers develop their own custom applications. VPort SDK PLUS is used to integrate video management systems with monitoring and control applications, such as SCADA systems, access control systems, and fire alarm systems. Moxa's VPort SDK PLUS includes CGI commands, ActiveX, and a C library and is available free of charge to system integrators and third-party software developers. Learning to use VPort SDK PLUS is easy, and detailed documentation and sample code is provided for quick reference. For detailed information about SDK PLUS, please visit Moxa's website at www.moxa.com.

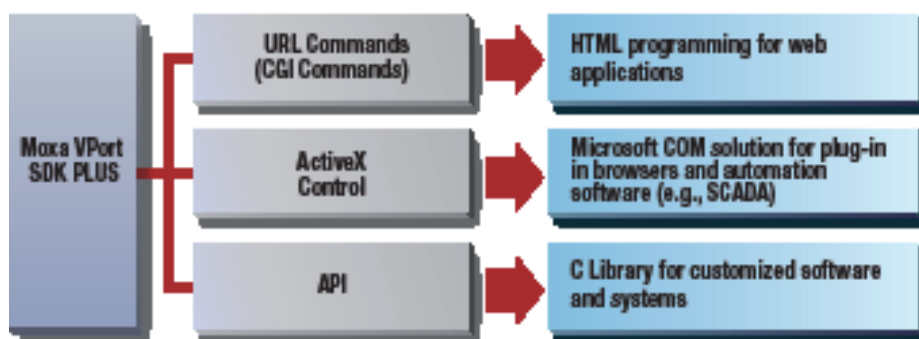

VPort Video Gadget

A Coding-free Programming Method Specially Designed for SCADA Systems

VPort Video Gadget, which is a new feature of VPort SDK PLUS, is a code-free tool for embedding surveillance video into a SCADA system. Only three simple steps are needed. Try it today and save time and engineering effort by adding visual management to your SCADA/HMI applications.

3 Steps for Integrating Visual-management with SCADA

Step 1 Drag & drop the selected function object



Step 2 Input the required parameters into the columns



Step 3 Save, and the function programming job is done!

Quick & Easy!

- Code-free programming
- 1 to 3 hour development time
- Supports Citect, InTouch, and Cimplicity third-party SCADA systems

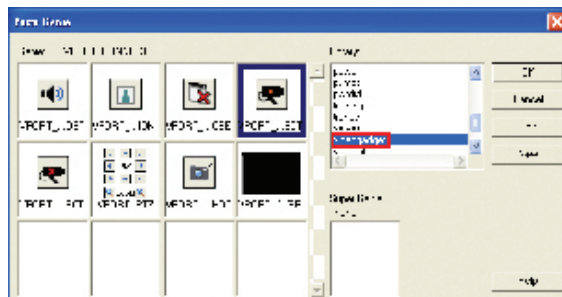

Industrial Device Networking

Reliable Device Networking for Remote Automation

- Reliable serial-to-Ethernet communication
- Ethernet backup solution
- Secure data communication and cyber management



Leading Device Networking for Remote Automation

Reliability is a crucial requirement for device networking in mission-critical remote automation applications such as DCS or SCADA systems for environmental monitoring or factory, transportation, and power automation applications.

Moxa offers a comprehensive spectrum of reliable device networking solutions to help system integrators create robust, secure, zero-data-loss architectures for mission-critical applications that incorporate both serial and Ethernet devices.

Port Buffering that Preserves Data During Ethernet Failures

For mission-critical applications, data collected from the serial device must be safeguarded even during Ethernet network interruptions. The NPort® 6000 series provides exceptionally reliable data transmission by saving serial data to an internal 64 KB port buffer if the Ethernet connection fails. When the Ethernet network is restored, data in the buffer is automatically released and sent to the appropriate destination. For the NPort® 6250, 6450, and 6650, this buffer can be further expanded by installing an SD card.

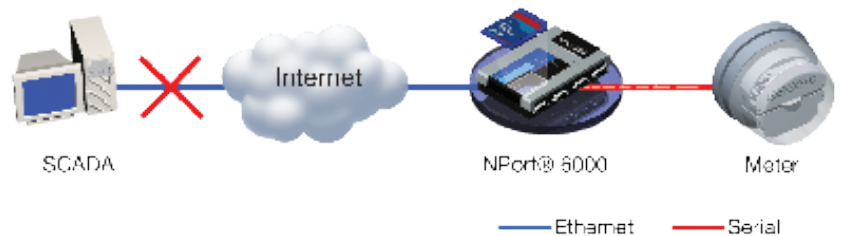

Ethernet Ring Redundancy with Fast Recovery

Moxa's NPort® 6000 secure terminal servers and NPort® S8000 combo switch / serial device servers support the following redundant protocols: STP, RSTP, and Moxa's own proprietary Turbo Ring™. With Turbo Ring™, if any segment of the daisy chain ring is disconnected, your network will recover in less than 20 ms.

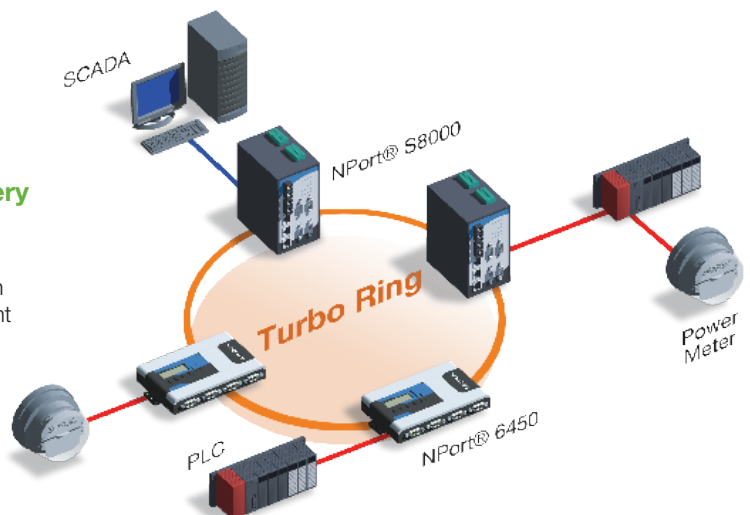

Back up Your Ethernet Connection

The NM-GPRS/GSM and NM-Modem network modules can be used to provide NPort® 6000 terminal servers with automatic communications backup. When the backup function is enabled, the NPort® 6000 will check the remote host connection on the Ethernet side after powering on. If it detects a connection failure, data from the serial device will be sent out through the GSM/GPRS and PSTN network. Data will again be sent through the Ethernet once the connection is restored. This NPort® 6000 backup function makes data transmission safer and more reliable.

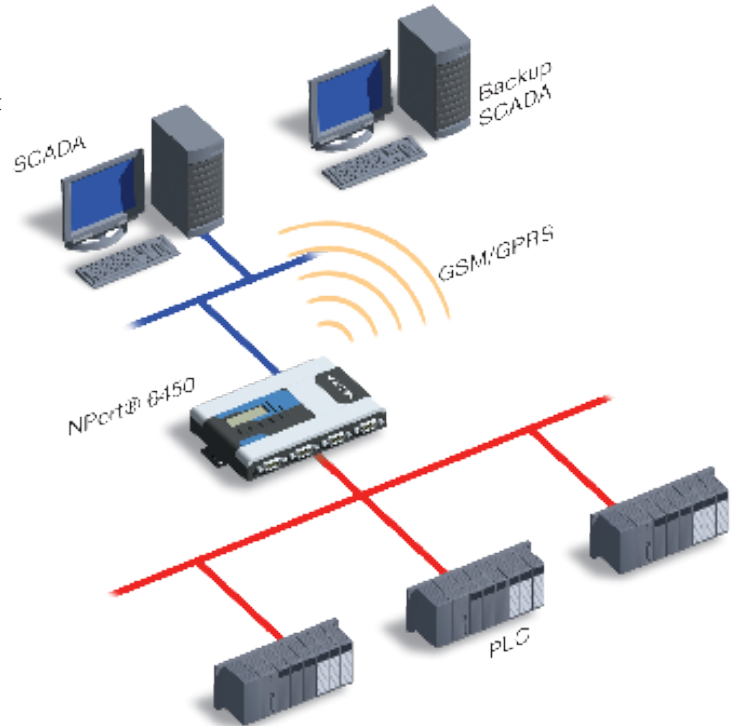

Secure Data Communication

Network security is critical for many applications, and is especially important when data is transmitted over the Internet where it is vulnerable to interception by third parties. The NPort® 6000 secure terminal servers use SSL to implement secure data transmission. NPort® drivers follow the SSL standard and automatically negotiate the encryption key to prevent hacker attacks.

Unauthorized access is also a major concern for system managers, and the NPort® 6000 secure terminal servers help control access by supporting IP filtering and password protection. Extra protection from hackers is provided by SSH and SSL. Secure configuration of the NPort® 6000 is provided by opening the web console with a web browser that supports https (e.g., Internet Explorer), or by opening the Telnet console using a terminal emulator that supports SSH (e.g., PuTTY).

Product Highlights

NPort® 6000

4-port RS-232/422/485 Secure Terminal Server

- LCD panel for easy IP address configuration
- Secure operation modes for Real COM, TCP Server, TCP Client, Pair Connection, Terminal, and Reverse Terminal
- *Any Baudrate* supported with high precision
- Port buffers for storing serial data when the Ethernet is off-line
- SD slot for expanding port buffer memory
- Slot for network expansion module

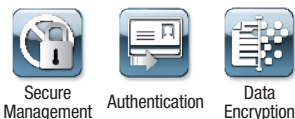

NPort® S8000

Combo Switch / Serial Device Server

- Serial QoS for configuring serial data transmission priority
- 2 KV (DC) isolation protection for each serial port
- Adjustable pull high/low resistor for RS-485 ports
- Ethernet redundancy with Turbo Ring™ or RSTP/STP (IEEE 802.1w/D) supported
- QoS, IGMP-snooping/GMRP, VLAN, LACP, SNMPv1/v2c/v3,
- RMON supported
- Surge protection for serial, power, and Ethernet



Industrial Ethernet Gateways

Easy-to-use Fieldbus Device Connectivity

- Easy Fieldbus and Ethernet gateway solutions
- Innovative and flexible Fieldbus to network applications
- Friendly user interface for configuration



Easy-to-use Fieldbus Device Connectivity

Modbus is the standard communication protocol for a wide range of industrial devices, including PLCs, DCSS, HMIs, instruments, meters, motors, and drives. Although Modbus can be used for both serial (RS-232, RS-422, and RS-485) devices and newer Ethernet devices, the serial and Ethernet protocols are so different that a specialized gateway is required for one protocol to communicate with the other. Moxa's MGate™ MB3000 series products are specially designed to integrate Modbus TCP and Modbus RTU/ASCII networks. DF1 is also a widely-used protocol on PLCs; Moxa's MGate™ EIP 3000 series offers a versatile gateway function to bring DF1 PLCs to Ethernet/IP networks.

Multiple Masters across Different Modbus Networks

The MGate™ MB3000 and MGate™ EIP3000 support 16 simultaneous TCP masters with up to 32 simultaneous requests per master. Serial masters are able to access up to 32 different IP addresses as TCP slaves. MGate™ MB3000 and MGate™ EIP3000 gateways have been designed so that even with multiple masters across different Modbus networks, communication remains compliant with each Modbus protocol.

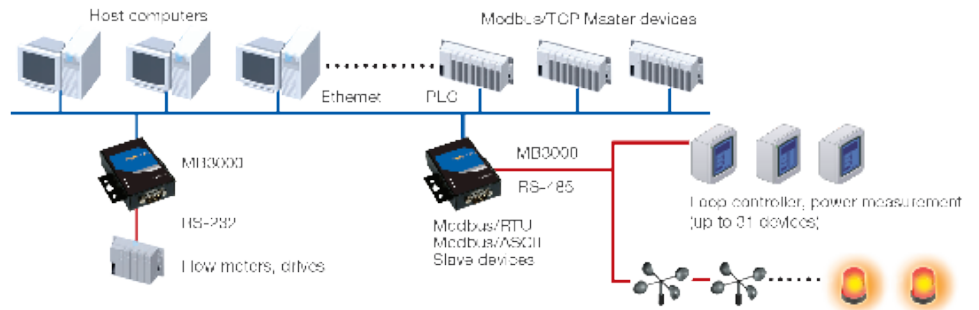

Ready-to-use ProCOM Technology ProCOM

Most existing host software uses COM ports as the interface for control. The MGate™ EIP3000 is much more than just a device server since it provides a COM mapping function and also retains DF1 connection capability. The MGate™ EIP3000 supports Windows 2000/XP/2003/Vista, and provides COM port mapping control of device servers, and DF1 behavior compatibility of gateways.

Each MGate™ EIP3000 gateway supports four virtual serial ports for remote control over an Ethernet connection.

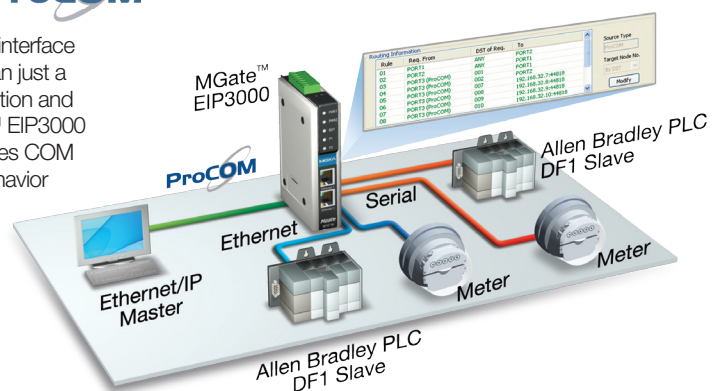

Priority Control for Critical Commands

The MGate™ MB3000 and MGate™ EIP3000 include a patent-pending priority control feature that allows urgent commands to be flagged for immediate response based on IP address, command type, or TCP port. Unlike conventional Modbus gateways that simply transfer all requests between Modbus networks on a FIFO (first in first out) basis, Moxa's Fieldbus gateway products are an ideal component of real-time control systems.



Smart Routing Simplifies Applications

The MGate™ MB3000 and MGate™ EIP3000 include smart routing for enhanced compatibility with existing Modbus networks. Other Modbus gateways require a separate socket connection for each serial port, making them useless for TCP masters that can only open one connection. With smart routing on the MB3000 Modbus gateway, a TCP master only needs one socket connection to command serial slaves on every serial port.

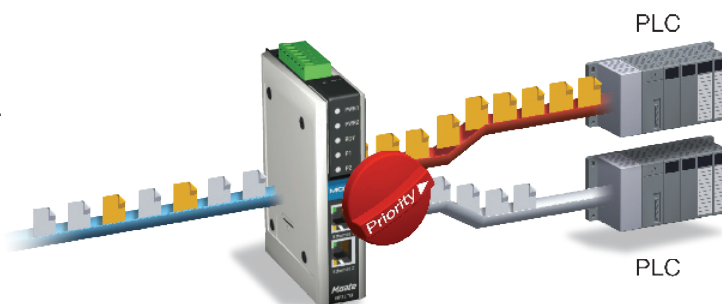

Product Highlights

MGate™ EIP3000

1 and 2-port EtherNet/IP to DF1 Gateways

- PCCC objects for Rockwell Automation networks supported
- Use ProCOM to implement control via COM port mapping
- 16 simultaneous EtherNet/IP client/server pairs with up to 16 requests queued
- Serial redirector function keeps connection of original serial master and slave while connecting devices to the Ethernet
- EtherNet/IP and DF1 protocol analyzer for easy troubleshooting



MGate™ MB3170/3270

1 and 2-port Advanced Serial-to-Ethernet Modbus Gateways

- Slave mode supports 16 TCP masters and up to 62 serial slaves at the same time
- Master mode supports 32 TCP slaves at the same time
- Serial redirector function provided
- Embedded Modbus protocol analyzer
- Redundant dual DC power inputs
- Built-in Ethernet cascading for easy wiring



Industrial Ethernet Switches and Routers

Industrial Ethernet Switches Tailored for Automation

- Media and power redundancy
- Intelligent networking features
- Industrial design: fanless, redundant power, -40 to 75°C operating temperature



EDS-619



Self-healing Ethernet

Modbus/TCP

IPv6



Leading-edge Chain and Ring Redundancy

Moxa's innovative Turbo Chain™ and proprietary Turbo Ring™ redundant technologies feature the fastest fault recovery time (under 20 ms) to ensure that your automation network runs continuously. Supported by all of Moxa's managed Ethernet switches, these recovery mechanisms allow you to create any type of self-healing recovery network to eliminate network failures and enable high availability.

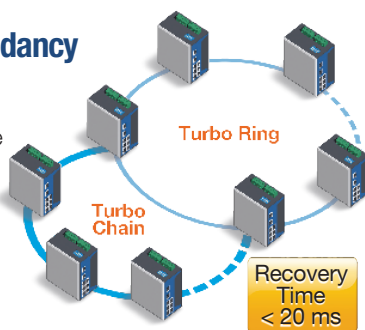

iNMS Visualizes Your Automation Networks

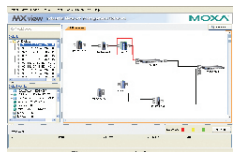

Visualize, monitor, configure, and troubleshoot your networks with MXview industrial network management software (iNMS). Use iNMS to monitor Moxa's managed Ethernet switches, wireless AP/Bridge/Client solutions, and other SNMP-enabled devices to ensure optimal network operations and reduce system downtime. Moxa's EDS-SNMP OPC server or Modbus/TCP compatible managed switches can help you directly integrate network status updates to your SCADA/HMI automation system for instant supervision.

Superior Network Management and Security Features

Deploy an Ethernet infrastructure with exceptional network management and integrated network security functions, including Layer 3 switching, Modbus/TCP, SNMP Inform, LLDP, DHCP Option 82, QoS, IGMP snooping, VLAN, as well as IEEE 802.1X, HTTPS, SSH, and SNMPv3 with Moxa's managed Ethernet switches. All of Moxa's Ethernet switches are IPv6-ready to allow seamless upgrading to next generation network standards.

Build Secure Automation Networks



EDR-G903 Series Industrial Gigabit Firewall/VPN Secure Router

- High performance Gigabit combo RJ45/SFP port
- Redundant WAN backup function
- Network Address Translation: N-to-1, 1-to-1, and port forwarding
- Quick Automation Profile, PolicyCheck, and SettingCheck functionality
- -40 to 75°C operating temperature

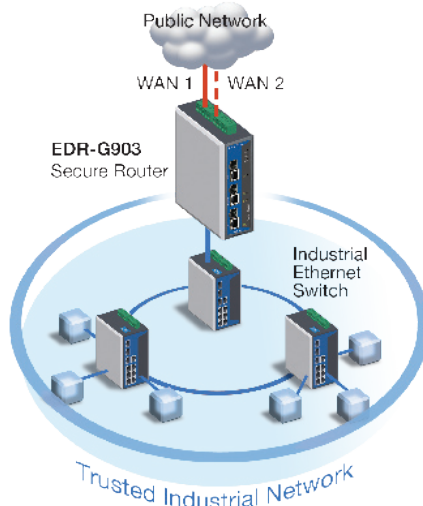

Get the Perfect Fit

A Vast Range of Industrial Ethernet Switches



DIN-Rail managed/unmanaged Ethernet switches



Rackmount managed/unmanaged Ethernet switches



PoE managed/unmanaged Ethernet switches



Industry-specific Ethernet switches for railway or power markets

Industrial Wireless AP/Bridge/Client

Reliable and Flexible Wireless Communications

- Moxa's proprietary Dual-RF design for wireless redundancy
- Enable stable wireless with Turbo Roaming and long distance transmission
- Industrial design for outdoor and indoor usage



Reliable and Flexible Wireless Communications

Moxa offers a wide range of IEEE 802.11a/b/g compliant industrial-grade products for indoor and outdoor applications. To provide greater flexibility, Moxa's AWK series products can be configured as access points, bridges, or clients, and support Turbo Roaming with a rapid handover time of less than 100 ms and long range wireless communications up to 10 km. In addition, the AWK-5222 and AWK-6222 are both equipped with Moxa's proprietary wireless redundancy technology, which features two independent RF modules with 2.4 or 5 GHz dual-band. With this technology, you can set up independent wireless connections to avoid interruptions in transmission, and provide flexible frequency configuration and superior reliability.

Built for Critical Environments

Moxa's AWK-4121 and AWK-6222 products have a tough, IP68-rated metal housing that is rugged enough to guard against the effects of water, oil, and dust. Even when subjected to severe vibrations and shocks, the M12 connectors ensure stability, making the AWK-4121 and AWK-6222 a natural fit for outdoor applications and other harsh environments.

Moxa's AWK series products are designed for harsh wireless applications, are compliant with E/e mark for motor vehicles, and EN50155 and EN50121 for railway applications.



AWK-6222 IEEE 802.11a/b/g Outdoor Dual-RF
Wireless AP/Bridge/Client



AWK-5222 IEEE 802.11a/b/g Indoor Dual-RF
Wireless AP/Bridge/Client



AWK-4121 IEEE 802.11a/b/g Outdoor Single RF
Wireless AP/Bridge/Client



AWK-3121 IEEE 802.11a/b/g Indoor Single RF
Wireless AP/Bridge/Client

- Redundant dual-RF design for rapid failover
- Industrial wireless AP/Bridge/Client with IEEE 802.11a/b/g
- Rapid Turbo Roaming under 100 ms
- Long-distance data transfer up to 10 km
- Dual DC power inputs and PoE for easy deployment

Industrial Wireless Overview

Model	Features					Security
	IEEE Standard	Dual-RF Module	IP Rating	RS-232 Console Port	Operating Temp.	
AWK-6222	802.11a/b/g/h, 802.3u, 802.3af	✓	IP68	Waterproof RJ45	-40 to 75°C	<ul style="list-style-type: none"> • SSID broadcast enable/disable • Firewall for MAC/IP/Protocol/Port-based filtering • 64-bit and 128-bit WEP encryption, WPA/WPA2 Personal and Enterprise (IEEE 802.11X/RADIUS, TKIP and AES)
AWK-5222		✓	IP30	RJ45	0 to 60°C -40 to 75°C	
AWK-4121		–	IP68	Waterproof RJ45	-40 to 75°C	
AWK-3121		–	IP30	RJ45	0 to 60°C -40 to 75°C	

Hot Products

Remote Ethernet I/O

ioLogik E1200 Series

- Daisy-chainable
- Easy wiring and expansion
- Saves cabling cost
- Push-based Active OPC Server
- 9 models with versatile I/O combinations



Programmable Automation Controller

ioPAC 8000

- EN50155 certified
- Hot-swappable I/O modules
- 2 RS-232/422/485 serial ports
- 2 LAN ports with M12 connectors
- Redundant dual VDC power input



**Coming
Soon!**

Active Ethernet Micro Controller

**Experience the
Easy-to-use ioLogik Now!**

ioLogik Starter Kit

- ioLogik E2212
- Evaluation board
- Power adaptor
- Quick startup guide
- ioLogik instruction video



ioLogik E2212

MOXA®

Moxa Europe

Tel: +49-89-3 70 03 99-0
Fax: +49-89-3 70 03 99-99
www.moxa.com
www.moxa.com/de
europe@moxa.com



Elmark Automatyka Sp. z o.o.

ul. Niemcewicza 76
05-075 Warszawa - Wesola
Poland
tel: +48 22 541-84-60
fax: +48 22 541-84-61
www.elmark.com.pl
moxa@elmark.com.pl