

CE Appendix Report

Product Name : RISC-Base Industrial Ready-to-Run Embedded Computer
Model No. : IA240-LX, IA240-T-LX, IA240-CE, IA240-T-CE, IA241-LX,
IA241-T-LX, IA241-CE, IA241-T-CE

Applicant : MOXA Inc.

Address : FL.4, NO. 135. LANE 235, BAOQIAO RD. XINDIAN
DIST.,NEW TAIPEI CITY, TAIWAN

Date of Receipt : 2011/05/02

Issued Date : 2013/10/31

Report No. : 139023R-ITCEP07V05

Report Version : V2.0



The test results relate only to the samples tested.

The test results shown in the test report are traceable to the national/international standard through the calibration of the equipment and evaluated measurement uncertainty herein.

This report must not be used to claim product endorsement by TAF or any agency of the Government.

The test report shall not be reproduced except in full without the written approval of Quietek Corporation.

Test Report Certification

Issued Date : 2013/10/31

Report No. : 139023R-ITCEP07V05



Product Name : RISC-based Industrial Ready-to-Run Embedded Computer
Applicant : MOXA Inc.
Address : FL.4, NO. 135. LANE 235, BAOQIAO RD. XINDIAN DIST.,NEW
TAIPEI CITY, TAIWAN
Manufacturer : MOXA Inc.
Model No. : IA240-LX, IA240-T-LX, IA240-CE, IA240-T-CE, IA241-LX,
IA241-T-LX, IA241-CE, IA241-T-CE
EUT Rated Voltage : DC 12 - 48V
EUT Test Voltage : AC 230 V / 50 Hz
Trade Name : MOXA
Applicable Standard : EN 55022: 2010+AC:2011, Class A
EN 55024: 2010
EN 61000-3-2: 2006+A2: 2009
EN 61000-3-3: 2008
Test Result : Complied
Performed Location : Quietek Corporation (Linkou Laboratory)
No.5-22, Ruishukeng, Linkou Dist., New Taipei City 24451,
Taiwan, R.O.C.
TEL:+866-2-8601-3788 / FAX:+886-2-8601-3789

Documented By : 
(Senior Adm. Specialist / Rita Huang)

Reviewed By : 
(Assistant Engineer / JoJolee Jung)

Approved By : 
(Manager / Vincent Lin)

Laboratory Information

We , **Quietek Corporation**, are an independent EMC and safety consultancy that was established the whole facility in our laboratories. The test facility has been accredited/accepted (audited or listed) by the following related bodies in compliance with ISO 17025, EN 45001 and specified testing scopes:

Taiwan R.O.C.	:	BSMI, NCC, TAF
Norway	:	Nemko, DNV
USA	:	FCC
Japan	:	VCCI

The related certificate for our laboratories about the test site and management system can be downloaded from Quietek Corporation's Web Site : <http://www.quietek.com/tw/ctg/cts/accreditations.htm>

The address and introduction of Quietek Corporation's laboratories can be founded in our Web site : <http://www.quietek.com/>

If you have any comments, Please don't hesitate to contact us. Our contact information is as below:

HsinChu Testing Laboratory :

No.75-2, 3rd Lin, Wangye Keng, Yonghxing Tsuen, Qionglin Shiang, Hsinchu County 307, Taiwan, R.O.C.

TEL:+886-3-592-8858 / FAX:+886-3-592-8859 E-Mail : service@quietek.com

LinKou Testing Laboratory :

No. 5-22, Ruei-Shu Valley, Ruei-Ping Tsuen, Lin-Kou Shiang, Taipei, Taiwan, R.O.C.

TEL : 886-2-8601-3788 / FAX : 886-2-8601-3789 E-Mail : service@quietek.com

Suzhou (China) Testing Laboratory :

No. 99 Hongye Rd., Suzhou Industrial Park Loufeng Hi-Tech Development Zone., Suzhou,China.

TEL : +86-512-6251-5088 / FAX : +86-512-6251-5098 E-Mail : service@quietek.com

TABLE OF CONTENTS

Description	Page
1. General Information	7
1.1. EUT Description.....	7
1.2. Mode of Operation	10
1.3. Tested System Details	11
1.4. Configuration of Tested System	11
1.5. EUT Exercise Software.....	12
2. Technical Test	13
2.1. Summary of Test Result.....	13
2.2. List of Test Equipment	14
2.3. Measurement Uncertainty.....	17
2.4. Test Environment.....	19
3. Conducted Emission (Main Terminals).....	20
3.1. Test Specification	20
3.2. Test Setup.....	20
3.3. Limit.....	20
3.4. Test Procedure	21
3.5. Deviation from Test Standard.....	21
3.6. Test Result	22
3.7. Test Photograph	28
4. Conducted Emissions (Telecommunication Ports).....	29
4.1. Test Specification	29
4.2. Test Setup.....	29
4.3. Limit.....	29
4.4. Test Procedure	30
4.5. Deviation from Test Standard.....	30
4.6. Test Result	31
4.7. Test Photograph	37
5. Radiated Emission	38
5.1. Test Specification	38
5.2. Test Setup.....	38
5.3. Limit.....	39
5.4. Test Procedure	40
5.5. Deviation from Test Standard.....	40
5.6. Test Result.....	41
5.7. Test Photograph	43
6. Harmonic Current Emission	44

6.1.	Test Specification	44
6.2.	Test Setup.....	44
6.3.	Limit.....	44
6.4.	Test Procedure	46
6.5.	Deviation from Test Standard.....	46
6.6.	Test Result.....	47
6.7.	Test Photograph	49
7.	Voltage Fluctuation and Flicker.....	50
7.1.	Test Specification.....	50
7.2.	Test Setup.....	50
7.3.	Limit.....	50
7.4.	Test Procedure	51
7.5.	Deviation from Test Standard.....	51
7.6.	Test Result.....	52
7.7.	Test Photograph	53
8.	Electrostatic Discharge	54
8.1.	Test Specification.....	54
8.2.	Test Setup.....	54
8.3.	Limit.....	54
8.4.	Test Procedure	55
8.5.	Deviation from Test Standard.....	55
8.6.	Test Result.....	56
8.7.	Test Photograph	57
9.	Radiated Susceptibility	58
9.1.	Test Specification.....	58
9.2.	Test Setup.....	58
9.3.	Limit.....	58
9.4.	Test Procedure	59
9.5.	Deviation from Test Standard.....	59
9.6.	Test Result.....	60
9.7.	Test Photograph	61
10.	Electrical Fast Transient/Burst.....	62
10.1.	Test Specification.....	62
10.2.	Test Setup.....	62
10.3.	Limit.....	62
10.4.	Test Procedure	63
10.5.	Deviation from Test Standard.....	63
10.6.	Test Result.....	64

10.7.	Test Photograph	65
11.	Surge	66
11.1.	Test Specification	66
11.2.	Test Setup.....	66
11.3.	Limit.....	66
11.4.	Test Procedure	67
11.5.	Deviation from Test Standard.....	67
11.6.	Test Result.....	68
11.7.	Test Photograph	69
12.	Conducted Susceptibility	70
12.1.	Test Specification	70
12.2.	Test Setup.....	70
12.3.	Limit.....	71
12.4.	Test Procedure	71
12.5.	Deviation from Test Standard.....	71
12.6.	Test Result.....	72
12.7.	Test Photograph	73
13.	Power Frequency Magnetic Field	74
13.1.	Test Specification	74
13.2.	Test Setup.....	74
13.3.	Limit.....	74
13.4.	Test Procedure	74
13.5.	Deviation from Test Standard.....	74
13.6.	Test Result.....	75
13.7.	Test Photograph	76
14.	Voltage Dips and Interruption.....	77
14.1.	Test Specification	77
14.2.	Test Setup.....	77
14.3.	Limit.....	77
14.4.	Test Procedure	78
14.5.	Deviation from Test Standard.....	78
14.6.	Test Result.....	79
14.7.	Test Photograph	80
15.	Attachment	81
	EUT Photograph.....	81

1. General Information

1.1. EUT Description

Product Name	RISC-Base Industrial Ready-to-Run Embedded Computer
Trade Name	MOXA
Model No.	IA240-LX, IA240-T-LX, IA240-CE, IA240-T-CE, IA241-LX, IA241-T-LX, IA241-CE, IA241-T-CE

Component	
Power Adapter (Optional)	MFR: ENG, M/N: 3A-165DA12 Input: AC 100-240V, 50-60Hz 0.4A Output: DC 12V-1.25A Cable out: Non-Shielded, 1.6m

- Note: 1. This appendix report was based on Quietek report No. 105171R-ITCE-P07V03.
 2. Modified for new Adapter.
 3. The EUT is including eight models for different marketing requirement.

Test Item		EN 55022 ITE Standard	EMI TEST
2.1 CE		<input checked="" type="checkbox"/> Class A	
		<input type="checkbox"/> Class B	
2.2	<input checked="" type="checkbox"/> Harmonics (AC only)	EN61000-3-2	
2.3	<input checked="" type="checkbox"/> Flicker (AC only)	EN61000-3-3	

EN 55024 ITE Standard		EMS TEST	Test Result				
			AC	DC	Signal		
3.1 ESD	EN61000-4-2	<input checked="" type="checkbox"/> Criteria A <input type="checkbox"/> Criteria B	<input type="checkbox"/> Level 1	Contact: 2kV	<input type="checkbox"/>	<input type="checkbox"/>	<input type="checkbox"/>
			<input checked="" type="checkbox"/> Level 2	Contact: 4kV	<input checked="" type="checkbox"/>	<input type="checkbox"/>	<input type="checkbox"/>
			<input type="checkbox"/> Level 3	Contact: 6kV	<input type="checkbox"/>	<input type="checkbox"/>	<input type="checkbox"/>
			<input type="checkbox"/> Level 4	Contact: 8kV	<input type="checkbox"/>	<input type="checkbox"/>	<input type="checkbox"/>
			<input type="checkbox"/> Level 1	Air: 2kV	<input type="checkbox"/>	<input type="checkbox"/>	<input type="checkbox"/>
			<input type="checkbox"/> Level 2	Air: 4kV	<input type="checkbox"/>	<input type="checkbox"/>	<input type="checkbox"/>
			<input checked="" type="checkbox"/> Level 3	Air: 8kV	<input checked="" type="checkbox"/>	<input type="checkbox"/>	<input type="checkbox"/>
			<input type="checkbox"/> Level 4	Air: 15kV	<input type="checkbox"/>	<input type="checkbox"/>	<input type="checkbox"/>
3.2 RF field strength susceptibility	EN61000-4-3	<input checked="" type="checkbox"/> Criteria A <input type="checkbox"/> Criteria B	<input type="checkbox"/> Level 1	80MHz – 1GHz, 1 V/m, 80%AM (1KHz)	<input type="checkbox"/>	<input type="checkbox"/>	<input type="checkbox"/>
			<input checked="" type="checkbox"/> Level 2	80MHz – 1GHz, 895-905 MHz, 1795-1805 MHz, 3 V/m, 80%AM (1KHz)	<input checked="" type="checkbox"/>	<input type="checkbox"/>	<input type="checkbox"/>
			<input type="checkbox"/> Level 3	80MHz – 1GHz, 10 V/m, 80% AM (1KHz)	<input type="checkbox"/>	<input type="checkbox"/>	<input type="checkbox"/>
3.3 Burst (EFT)	EN61000-4-4 <input checked="" type="checkbox"/> AC <input type="checkbox"/> DC <input checked="" type="checkbox"/> Signal I/O	<input checked="" type="checkbox"/> Criteria A <input type="checkbox"/> Criteria B	<input type="checkbox"/> Level 1	AC Power 0.5kV	<input type="checkbox"/>	<input type="checkbox"/>	<input type="checkbox"/>
			<input checked="" type="checkbox"/> Level 2	AC Power: 1kV	<input checked="" type="checkbox"/>	<input type="checkbox"/>	<input type="checkbox"/>
			<input type="checkbox"/> Level 3	AC Power: 2kV	<input type="checkbox"/>	<input type="checkbox"/>	<input type="checkbox"/>
			<input type="checkbox"/> Level 4	AC Power: 4kV	<input type="checkbox"/>	<input type="checkbox"/>	<input type="checkbox"/>
			<input type="checkbox"/> Level 1	DC Power: 0.5kV	<input type="checkbox"/>	<input type="checkbox"/>	<input type="checkbox"/>
			<input type="checkbox"/> Level 2	DC Power: 1kV	<input type="checkbox"/>	<input type="checkbox"/>	<input type="checkbox"/>
			<input type="checkbox"/> Level 3	DC Power: 2kV	<input type="checkbox"/>	<input type="checkbox"/>	<input type="checkbox"/>
			<input type="checkbox"/> Level 4	DC Power: 4kV	<input type="checkbox"/>	<input type="checkbox"/>	<input type="checkbox"/>
			<input type="checkbox"/> Level 1	I/O line: 0.25kV	<input type="checkbox"/>	<input type="checkbox"/>	<input type="checkbox"/>
			<input checked="" type="checkbox"/> Level 2	I/O line: 0.5kV	<input type="checkbox"/>	<input type="checkbox"/>	<input checked="" type="checkbox"/>
			<input type="checkbox"/> Level 3	I/O line: 1kV	<input type="checkbox"/>	<input type="checkbox"/>	<input type="checkbox"/>
			<input type="checkbox"/> Level 4	I/O line: 2kV	<input type="checkbox"/>	<input type="checkbox"/>	<input type="checkbox"/>
3.4 Surge (Power)	EN61000-4-5 <input checked="" type="checkbox"/> AC <input type="checkbox"/> DC	<input type="checkbox"/> Criteria A <input checked="" type="checkbox"/> Criteria B	<input type="checkbox"/> Level 1	AC L-PE: 0.5kV AC L-L : 0.25kV	<input type="checkbox"/>	<input type="checkbox"/>	<input type="checkbox"/>
			<input type="checkbox"/> Level 2	AC L-PE: 1kV AC L-L : 0.5kV	<input type="checkbox"/>	<input type="checkbox"/>	<input type="checkbox"/>

			<input checked="" type="checkbox"/> Level 3	AC L-L : 1kV	<input checked="" type="checkbox"/>	<input type="checkbox"/>	<input type="checkbox"/>
			<input type="checkbox"/> Level 4	AC L-PE: 4kV AC L-L : 2kV	<input type="checkbox"/>	<input type="checkbox"/>	<input type="checkbox"/>
			<input type="checkbox"/> Level 1	DC L-L: 0.25KV DC L-PE: 0.5kV	<input type="checkbox"/>	<input type="checkbox"/>	<input type="checkbox"/>
			<input type="checkbox"/> Level 2	DC L-L: 0.5kV DC L-PE: 1kV	<input type="checkbox"/>	<input type="checkbox"/>	<input type="checkbox"/>
			<input type="checkbox"/> Level 3	DC L-L: 1kV DC L-PE: 2kV	<input type="checkbox"/>	<input type="checkbox"/>	<input type="checkbox"/>
			<input type="checkbox"/> Level 4	DC L-L: 2kV DC L-PE: 4kV	<input type="checkbox"/>	<input type="checkbox"/>	<input type="checkbox"/>
3.5 Surge (Communication Line)	EN61000-4-5 Signal I/O	<input type="checkbox"/> Criteria A <input type="checkbox"/> Criteria B	<input type="checkbox"/> Level 1	0.5kV	<input type="checkbox"/>	<input type="checkbox"/>	<input type="checkbox"/>
			<input type="checkbox"/> Level 2	1kV	<input type="checkbox"/>	<input type="checkbox"/>	<input type="checkbox"/>
			<input type="checkbox"/> Level 3	2kV	<input type="checkbox"/>	<input type="checkbox"/>	<input type="checkbox"/>
			<input type="checkbox"/> Level 4	4kV	<input type="checkbox"/>	<input type="checkbox"/>	<input type="checkbox"/>
3.6 CS	EN61000-4-6 <input checked="" type="checkbox"/> AC <input type="checkbox"/> DC <input checked="" type="checkbox"/> Signal I/O	<input checked="" type="checkbox"/> Criteria A <input type="checkbox"/> Criteria B	<input type="checkbox"/> Level 1	150 kHz - 80 MHz 1 V/m, 80%AM (1KHz)	<input type="checkbox"/>	<input type="checkbox"/>	<input type="checkbox"/>
			<input type="checkbox"/> Level 2	150 kHz - 80 MHz 3 V/m, 80%AM (1KHz)	<input type="checkbox"/>	<input type="checkbox"/>	<input type="checkbox"/>
			<input checked="" type="checkbox"/> Level 3	150 kHz - 80 MHz 10 V/m, 80%AM (1KHz)	<input checked="" type="checkbox"/>	<input type="checkbox"/>	<input type="checkbox"/>
			<input type="checkbox"/> Level 1	I/O line: 1 V/m	<input type="checkbox"/>	<input type="checkbox"/>	<input type="checkbox"/>
			<input type="checkbox"/> Level 2	I/O line: 3 V/m	<input type="checkbox"/>	<input type="checkbox"/>	<input type="checkbox"/>
			<input checked="" type="checkbox"/> Level 3	I/O line: 10 V/m	<input type="checkbox"/>	<input type="checkbox"/>	<input checked="" type="checkbox"/>
3.7 PFMF (Magnetic Field)	EN61000-4-8	<input checked="" type="checkbox"/> Criteria A <input type="checkbox"/> Criteria B	<input checked="" type="checkbox"/> Level 1	1 A/m	<input checked="" type="checkbox"/>	<input type="checkbox"/>	<input type="checkbox"/>
			<input type="checkbox"/> Level 2	3 A/m	<input type="checkbox"/>	<input type="checkbox"/>	<input type="checkbox"/>
			<input type="checkbox"/> Level 3	10 A/m	<input type="checkbox"/>	<input type="checkbox"/>	<input type="checkbox"/>
			<input type="checkbox"/> Level 4	30 A/m	<input type="checkbox"/>	<input type="checkbox"/>	<input type="checkbox"/>
			<input type="checkbox"/> Level 5	100 A/m	<input type="checkbox"/>	<input type="checkbox"/>	<input type="checkbox"/>
			<input type="checkbox"/> X	125 A/m	<input type="checkbox"/>	<input type="checkbox"/>	<input type="checkbox"/>
3.8 Dips (AC only)	EN61000-4-11	<input checked="" type="checkbox"/> Criteria A <input checked="" type="checkbox"/> Criteria B <input type="checkbox"/> Criteria C	<input checked="" type="checkbox"/> Criteria A	>95% reduction (Voltage Dips), 0.5period>	<input checked="" type="checkbox"/>	<input type="checkbox"/>	<input type="checkbox"/>
			<input type="checkbox"/> Criteria B		<input type="checkbox"/>	<input type="checkbox"/>	<input type="checkbox"/>
			<input type="checkbox"/> Criteria C		<input type="checkbox"/>	<input type="checkbox"/>	<input type="checkbox"/>
			<input checked="" type="checkbox"/> Criteria A	30% reduction (Voltage Dips), 25 period	<input checked="" type="checkbox"/>	<input type="checkbox"/>	<input type="checkbox"/>
			<input type="checkbox"/> Criteria B		<input type="checkbox"/>	<input type="checkbox"/>	<input type="checkbox"/>
			<input type="checkbox"/> Criteria C		<input type="checkbox"/>	<input type="checkbox"/>	<input type="checkbox"/>
			<input type="checkbox"/> Criteria A	> 95% reduction (Voltage Interruptions), 250 period	<input type="checkbox"/>	<input type="checkbox"/>	<input type="checkbox"/>
			<input checked="" type="checkbox"/> Criteria B		<input checked="" type="checkbox"/>	<input type="checkbox"/>	<input type="checkbox"/>
<input type="checkbox"/> Criteria C	<input type="checkbox"/>	<input type="checkbox"/>	<input type="checkbox"/>				

1.2. Mode of Operation

Quietek has verified the construction and function in typical operation. All the test modes were carried out with the EUT in normal operation, which was shown in this test report and defined as:

Pre-Test Mode	
Mode 1: Normal Operation	
Final Test Mode	
Emission	Mode 1: Normal Operation
Immunity	Mode 1: Normal Operation

1.3. Tested System Details

The types for all equipments, plus descriptions of all cables used in the tested system (including inserted cards) are:

Product	Manufacturer	Model No.	Serial No.	Power Cord	
1	iPod nano (EMI)	Apple	A1236	7K823E51Y0P	N/A
	iPod nano (EMS)	Apple	A1199	5U728909VQ5	N/A
2	Notebook PC	DELL	PP04X	C8YYM1S	Non-Shielded, 0.8m

1.4. Configuration of Tested System

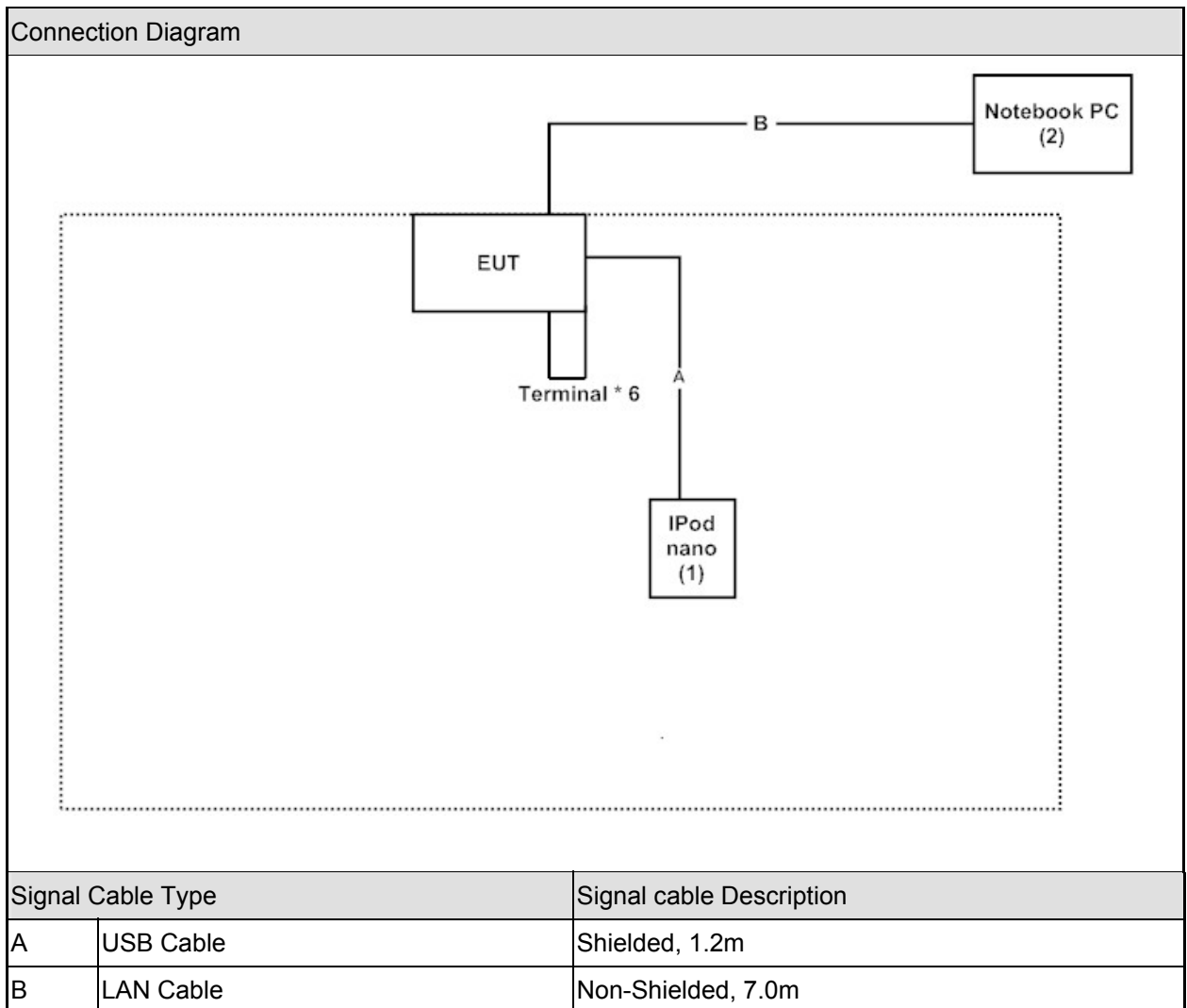

1.5. EUT Exercise Software

1	Setup the EUT and simulators as shown on 1.4.
2	Turn on the power of all equipment.
3	A multi meter was used to verify the model operation before the measurement.

2. Technical Test

2.1. Summary of Test Result

- No deviations from the test standards
 Deviations from the test standards as below description:

Emission			
Performed Item	Normative References	Test Performed	Deviation
Conducted Emission	EN 55022:2010+AC: 2011	Yes	No
Impedance Stabilization Network	EN 55022:2010+AC: 2011	Yes	No
Radiated Emission	EN 55022:2010+AC: 2011	Yes	No
Power Harmonics	EN 61000-3-2: 2006+A2: 2009	Yes	No
Voltage Fluctuation and Flicker	EN 61000-3-3: 2008	Yes	No

Immunity			
Performed Item	Normative References	Test Performed	Deviation
Electrostatic Discharge	IEC 61000-4-2 Ed. 2.0: 2008	Yes	No
Radiated susceptibility	IEC 61000-4-3 Ed. 3.2: 2010	Yes	No
Electrical fast transient/burst	IEC 61000-4-4 Ed. 3.0: 2012	Yes	No
Surge	IEC 61000-4-5 Ed. 2.0: 2005	Yes	No
Conducted susceptibility	IEC 61000-4-6 Ed. 3.0: 2008	Yes	No
Power frequency magnetic field	IEC 61000-4-8 Ed. 2.0: 2009	Yes	No
Voltage dips and interruption	IEC 61000-4-11 Ed. 2.0: 2004	Yes	No

2.2. List of Test Equipment

Conducted Emission / SR1

Instrument	Manufacturer	Type No.	Serial No	Cal. Date
EMI Test Receiver	R&S	ESCS 30	100366	2010/11/10
LISN	R&S	ENV4200	833209/007	2010/09/06
LISN	R&S	ENV216	100085	2011/02/10
Pulse Limiter	R&S	ESH3-Z2	357.88.10.52	2010/09/02

Impedance Stabilization Network / SR1

Instrument	Manufacturer	Type No.	Serial No	Cal. Date
Capacitive Voltage Probe	Schaffner	CVP2200A	18331	2010/11/15
EMI Test Receiver	R&S	ESCS 30	100366	2010/11/10
LISN	R&S	ENV216	100085	2011/02/10
LISN	R&S	ENV4200	833209/007	2010/09/06
Pulse Limiter	R&S	ESH3-Z2	357.88.10.52	2010/09/02
RF Current Probe	FCC	F-65 10KHz~1GHz	198	2010/11/08
BALANCED TELECOM ISN	FCC	FCC-TLISN-T2-02	20316	2010/06/26
BALANCED TELECOM ISN	FCC	FCC-TLISN-T4-02	20317	2010/06/26
BALANCED TELECOM ISN	FCC	FCC-TLISN-T8-02	20319	2010/06/26

Radiated Emission / Site1

Instrument	Manufacturer	Type No.	Serial No	Cal. Date
Bilog Antenna	Schaffner Chase	CBL6112B	2918	2010/08/01
Broadband Horn Antenna	Schwarzbeck	BBHA9170	209	2010/10/27
EMI Test Receiver	R&S	ESCS 30	100121	2010/12/06
Horn Antenna	Schwarzbeck	BBHA9120D	305	2010/08/26
Pre-Amplifier	QTK	N/A	N/A	2010/08/01
Spectrum Analyzer	Advantest	R3162	100803482	2010/11/10

Power Harmonics / SR3

Instrument	Manufacturer	Type No.	Serial No	Cal. Date
AC Power Source(Harmonic)	Schaffner	NSG 1007	HK54148	2010/09/06
IEC1000-4-X Analyzer(Flicker)	Schaffner	CCN 1000-1	X7 1887	2010/09/06

Voltage Fluctuation and Flicker / SR3

Instrument	Manufacturer	Type No.	Serial No	Cal. Date
AC Power Source(Harmonic)	Schaffner	NSG 1007	HK54148	2010/09/06
IEC1000-4-X Analyzer(Flicker)	Schaffner	CCN 1000-1	X7 1887	2010/09/06

Electrostatic Discharge / SR6

Instrument	Manufacturer	Type No.	Serial No	Cal. Date
ESD Simulator System	Noiseken	TC-815R	ESS0929097	2010/08/30
Horizontal Coupling Plane(HCP)	Quietek	HCP AL50	N/A	N/A
Vertical Coupling Plane(VCP)	Quietek	VCP AL50	N/A	N/A

Radiated susceptibility / CB5

Instrument	Manufacturer	Type No.	Serial No	Cal. Date
AF-BOX	R&S	AF-BOX ACCUST	100007	N/A
Audio Analyzer	R&S	UPL 16	100137	2011/04/21
Biconilog Antenna	EMCO	3149	00071675	N/A
Directional Coupler	A&R	DC 6180	22735	N/A
Dual Microphone Supply	B&K	5935	2426784	2011/04/21
Mouth Simulator	B&K	4227	2439692	2011/04/21
Power Amplifier	A&R	30S1G3	309453	N/A
Power Amplifier	A&R	100W10000M7	A285000010	N/A
Power Amplifier	SCHAFFNER	CBA9413B	4020	N/A
Power Amplifier	AR	75A250A	0325371	N/A
Power Meter	R&S	NRVD(P.M)	100219	2011/04/21
Pre-Amplifier	A&R	150A220	23067	N/A
Probe Microphone	B&K	4182	2278070	2011/04/21
Signal Generator	R&S	SML03	103300	2010/05/09

Electrical fast transient/burst / SR3

Instrument	Manufacturer	Type No.	Serial No	Cal. Date
TRANSIENT TEST SYSTEM	EMC PARTNER	TRA2000IN6	1138	2010/12/09

Surge / SR3

Instrument	Manufacturer	Type No.	Serial No	Cal. Date
TRANSIENT TEST SYSTEM	EMC PARTNER	TRA2000IN6	1138	2010/12/09

Conducted susceptibility / SR6

Instrument	Manufacturer	Type No.	Serial No	Cal. Date
Schaffner NSG 2070 RF-Generator	Schaffner	N/A	N/A	2011/04/07

Power frequency magnetic field / SR3

Instrument	Manufacturer	Type No.	Serial No	Cal. Date
Induction Coil Interface	Schaffner	INA 2141	6002	N/A
Magnetic Loop Coil	Schaffner	INA 702	160	N/A

Voltage dips and interruption / SR3

Instrument	Manufacturer	Type No.	Serial No	Cal. Date
TRANSIENT TEST SYSTEM	EMC PARTNER	TRA2000IN6	1138	2010/12/09

Schaffner NSG 2070 RF-Generator

Instrument	Manufacturer	Type No.	Serial No	Cal. Date
CDN	Schaffner	CAL U100A	20405	N/A
CDN	Schaffner	TRA U150	20454	N/A
CDN M016S	Schaffner	CAL U100A	20410	N/A
CDN M016S	Schaffner	TRA U150	21167	N/A
CDN T002	Schaffner	CAL U100	20491	N/A
CDN T002	Schaffner	TRA U150	21169	N/A
CDN T400	Schaffner	CAL U100	17735	N/A
CDN T400	Schaffner	TRA U150	21166	N/A
Coupling Decoupling Network	Schaffner	CDN M016S	20823	2011/04/08

Coupling Decoupling Network	Schaffner	CDN T002	19018	2011/04/08
Coupling Decoupling Network	Schaffner	CDN T400	21226	2011/04/08
EM-CLAMP	Schaffner	KEMZ 801	21024	2011/04/08

2.3. Measurement Uncertainty

Conducted Emission

The measurement uncertainty is evaluated as ± 2.26 dB.

Impedance Stabilization Network

The measurement uncertainty is evaluated as ± 2.26 dB.

Radiated Emission

The measurement uncertainty is evaluated as ± 3.19 dB.

Harmonic Current Emission

The measurement uncertainty is evaluated as 5.1 (mA/A).

Voltage Fluctuation and Flicker

The measurement uncertainty is evaluated as 0.6 (mV/V).

Electrostatic Discharge

As what is concluded in the document from Note2 of clause 5.4.6.2 of ISO/IEC 17025, the requirements for measurement uncertainty in ESD testing are deemed to have been satisfied, and the testing is reported in accordance with the relevant ESD standards. The immunity test signal from the ESD system meet the required specifications in IEC 61000-4-2 through the calibration report with the calibrated uncertainty for the waveform of current and timing as being 7.8 % and 3.2%.

Radiated susceptibility

As what is concluded in the document from Note2 of clause 5.4.6.2 of ISO/IEC 17025, the requirements for measurement uncertainty in RS testing are deemed to have been satisfied, and the testing is reported in accordance with the relevant RS standards. The immunity test signal from the RS system meet the required specifications in IEC 61000-4-3 through the calibration for the uniform field strength and monitoring for the test level with the uncertainty evaluation report for the electrical filed strength as being 3.57 dB.

Electrical fast transient/burst

As what is concluded in the document from Note2 of clause 5.4.6.2 of ISO/IEC 17025, the requirements for measurement uncertainty in EFT/Burst testing are deemed to have been satisfied, and the testing is reported in accordance with the relevant EFT/Burst standards. The immunity test signal from the EFT/Burst system meet the required specifications in IEC 61000-4-4 through the calibration report with the calibrated uncertainty for the waveform of voltage and timing as being 8.3 % and 5.4%.

Surge

As what is concluded in the document from Note2 of clause 5.4.6.2 of ISO/IEC 17025, the requirements for measurement uncertainty in Surge testing are deemed to have been satisfied, and the testing is reported in accordance with the relevant Surge standards. The immunity test signal from the Surge system meet the required specifications in IEC 61000-4-5 through the calibration report with the calibrated uncertainty for the waveform of voltage and timing as being 4.4 % and 5.9%.

Conducted susceptibility

As what is concluded in the document from Note2 of clause 5.4.6.2 of ISO/IEC 17025, the requirements for measurement uncertainty in CS testing are deemed to have been satisfied, and the testing is reported in accordance with the relevant CS standards. The immunity test signal from the CS system meet the required specifications in IEC 61000-4-6 through the calibration for unmodulated signal and monitoring for the test level with the uncertainty evaluation report for the injected modulated signal level through CDN and EM Clamp/Direct Injection as being 2.0 dB and 2.61 dB.

Power frequency magnetic field

As what is concluded in the document from Note2 of clause 5.4.6.2 of ISO/IEC 17025, the requirements for measurement uncertainty in PFM testing are deemed to have been satisfied, and the testing is reported in accordance with the relevant PFM standards. The immunity test signal from the PFM system meet the required specifications in IEC 61000-4-8 through the calibration report with the calibrated uncertainty for the Gauss Meter to verify the output level of magnetic field strength as being 1.0 %.

Voltage dips and interruption

As what is concluded in the document from Note2 of clause 5.4.6.2 of ISO/IEC 17025, the requirements for measurement uncertainty in DIP testing are deemed to have been satisfied, and the testing is reported in accordance with the relevant DIP standards. The immunity test signal from the DIP system meet the required specifications in IEC 61000-4-11 through the calibration report with the calibrated uncertainty for the waveform of voltage and timing as being 1.6 % and 2.8%.

2.4. Test Environment

Performed Item	Items	Required	Actual
Conducted Emission	Temperature (°C)	15-35	25
	Humidity (%RH)	25-75	50
	Barometric pressure (mbar)	860-1060	950-1000
Impedance Stabilization Network	Temperature (°C)	15-35	25
	Humidity (%RH)	25-75	50
	Barometric pressure (mbar)	860-1060	950-1000
Radiated Emission	Temperature (°C)	15-35	25
	Humidity (%RH)	25-75	50
	Barometric pressure (mbar)	860-1060	950-1000
Electrostatic Discharge	Temperature (°C)	15-35	22
	Humidity (%RH)	30-60	49
	Barometric pressure (mbar)	860-1060	950-1000
Radiated susceptibility	Temperature (°C)	15-35	24
	Humidity (%RH)	25-75	51
	Barometric pressure (mbar)	860-1060	950-1000
Electrical fast transient/burst	Temperature (°C)	15-35	24
	Humidity (%RH)	25-75	57
	Barometric pressure (mbar)	860-1060	950-1000
Surge	Temperature (°C)	15-35	24
	Humidity (%RH)	10-75	51
	Barometric pressure (mbar)	860-1060	950-1000
Conducted susceptibility	Temperature (°C)	15-35	24
	Humidity (%RH)	25-75	51
	Barometric pressure (mbar)	860-1060	950-1000
Power frequency magnetic field	Temperature (°C)	15-35	24
	Humidity (%RH)	25-75	51
	Barometric pressure (mbar)	860-1060	950-1000
Voltage dips and interruption	Temperature (°C)	15-35	24
	Humidity (%RH)	25-75	51
	Barometric pressure (mbar)	860-1060	950-1000

3. Conducted Emission (Main Terminals)

3.1. Test Specification

According to EMC Standard : EN 55022

3.2. Test Setup

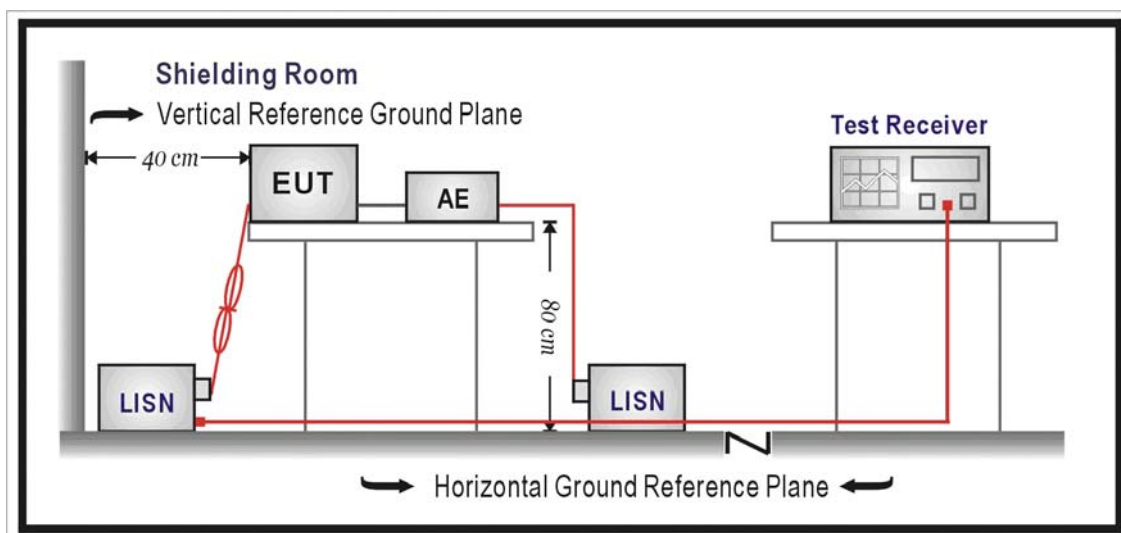

3.3. Limit

Limits		
Frequency (MHz)	QP (dBuV)	AV (dBuV)
0.15 - 0.50	79	66
0.50-5.0	73	60
5.0 - 30	73	60

Remarks: In the above table, the tighter limit applies at the band edges.

3.4. Test Procedure

The EUT and simulators are connected to the main power through a line impedance stabilization network (L.I.S.N.). This provides a 50 ohm /50uH coupling impedance for the measuring equipment. The peripheral devices are also connected to the main power through a LISN that provides a 50ohm/50uH coupling impedance with 50ohm termination.

(Please refers to the block diagram of the test setup and photographs.)

Both sides of A.C. line are checked for maximum conducted interference. In order to find the maximum emission, the relative positions of equipment and all of the interface cables must be changed on conducted measurement.

Conducted emissions were invested over the frequency range from 0.15MHz to 30MHz using a receiver bandwidth of 9kHz.

3.5. Deviation from Test Standard

No deviation.

3.6. Test Result

Site : SR_1	Time : 2011/05/06 - 05:10
Limit : CISPR_A_00M_QP	Margin : 10
EUT : RISC-Base Industrial Ready-to-Run Embedded Computer	Probe : ENV_216_L1 - Line1
Power : AC 230V/50Hz	Note : Mode 1



Site : SR_1	Time : 2011/05/06 - 05:12
Limit : CISPR_A_00M_QP	Margin : 0
EUT : RISC-Base Industrial Ready-to-Run Embedded Computer	Probe : ENV_216_L1 - Line1
Power : AC 230V/50Hz	Note : Mode 1

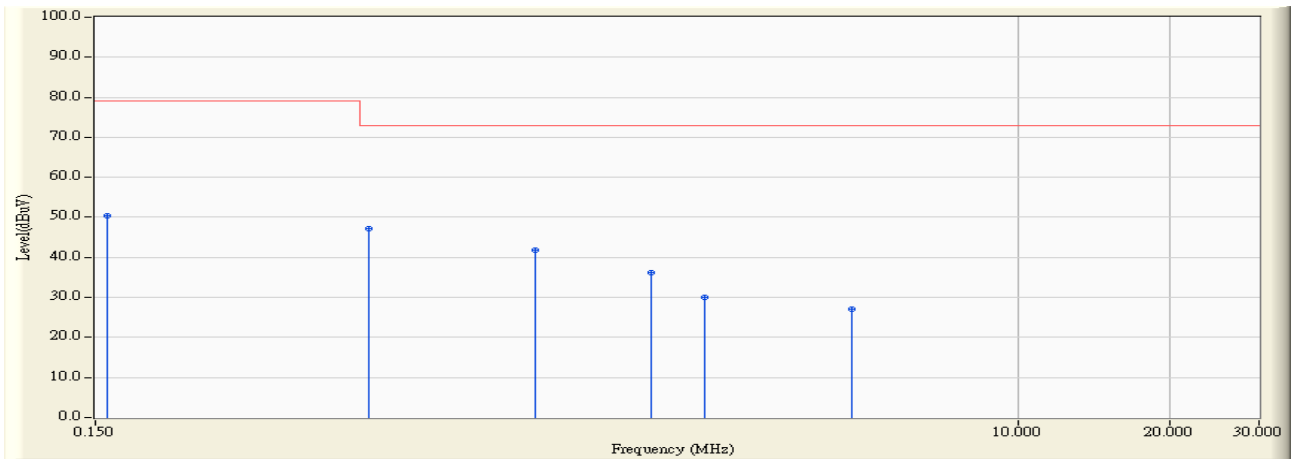

		Frequency (MHz)	Correct Factor (dB)	Reading Level (dBuV)	Measure Level (dBuV)	Margin (dB)	Limit (dBuV)	Detector Type
1		0.158	9.790	40.730	50.520	-28.480	79.000	QUASIPeAK
2	*	0.521	9.790	37.370	47.160	-25.840	73.000	QUASIPeAK
3		1.115	9.800	32.050	41.850	-31.150	73.000	QUASIPeAK
4		1.884	9.810	26.330	36.140	-36.860	73.000	QUASIPeAK
5		2.404	9.810	20.130	29.940	-43.060	73.000	QUASIPeAK
6		4.709	9.830	17.130	26.960	-46.040	73.000	QUASIPeAK

Note:

1. All Reading Levels are Quasi-Peak and average value.
2. " * ", means this data is the worst emission level.
3. Measurement Level = Reading Level + Correct Factor

Site : SR_1	Time : 2011/05/06 - 05:12
Limit : CISPR_A_00M_AV	Margin : 0
EUT : RISC-Base Industrial Ready-to-Run Embedded Computer	Probe : ENV_216_L1 - Line1
Power : AC 230V/50Hz	Note : Mode 1

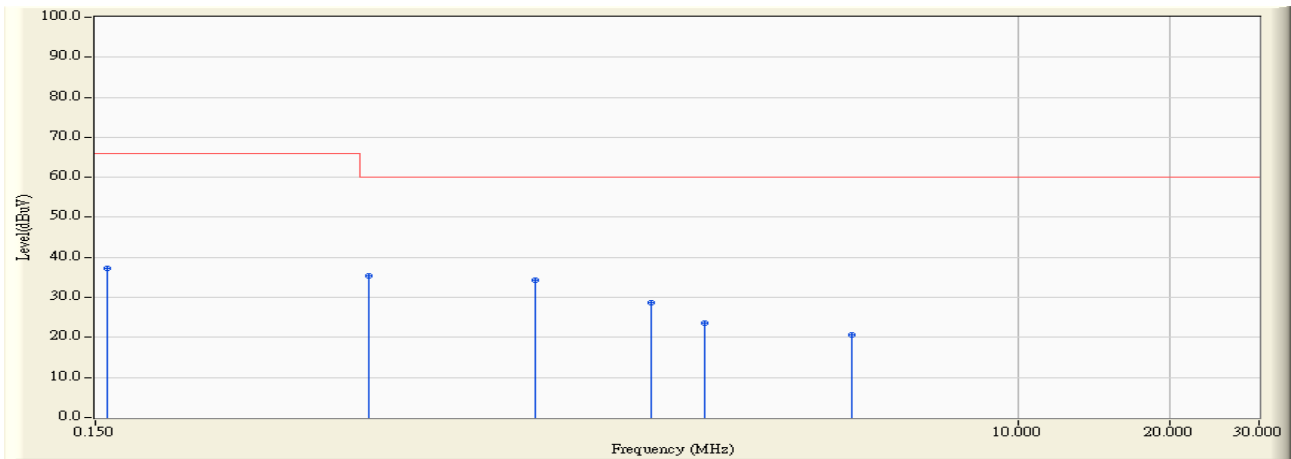

		Frequency (MHz)	Correct Factor (dB)	Reading Level (dBuV)	Measure Level (dBuV)	Margin (dB)	Limit (dBuV)	Detector Type
1		0.158	9.790	27.560	37.350	-28.650	66.000	AVERAGE
2	*	0.521	9.790	25.630	35.420	-24.580	60.000	AVERAGE
3		1.115	9.800	24.530	34.330	-25.670	60.000	AVERAGE
4		1.884	9.810	19.000	28.810	-31.190	60.000	AVERAGE
5		2.404	9.810	13.810	23.620	-36.380	60.000	AVERAGE
6		4.709	9.830	10.820	20.650	-39.350	60.000	AVERAGE

Note:

1. All Reading Levels are Quasi-Peak and average value.
2. " * ", means this data is the worst emission level.
3. Measurement Level = Reading Level + Correct Factor

Site : SR_1	Time : 2011/05/06 - 05:12
Limit : CISPR_A_00M_QP	Margin : 10
EUT : RISC-Base Industrial Ready-to-Run Embedded Computer	Probe : ENV_216_N - Line2
Power : AC 230V/50Hz	Note : Mode 1



Site : SR_1	Time : 2011/05/06 - 05:13
Limit : CISPR_A_00M_QP	Margin : 0
EUT : RISC-Base Industrial Ready-to-Run Embedded Computer	Probe : ENV_216_N - Line2
Power : AC 230V/50Hz	Note : Mode 1

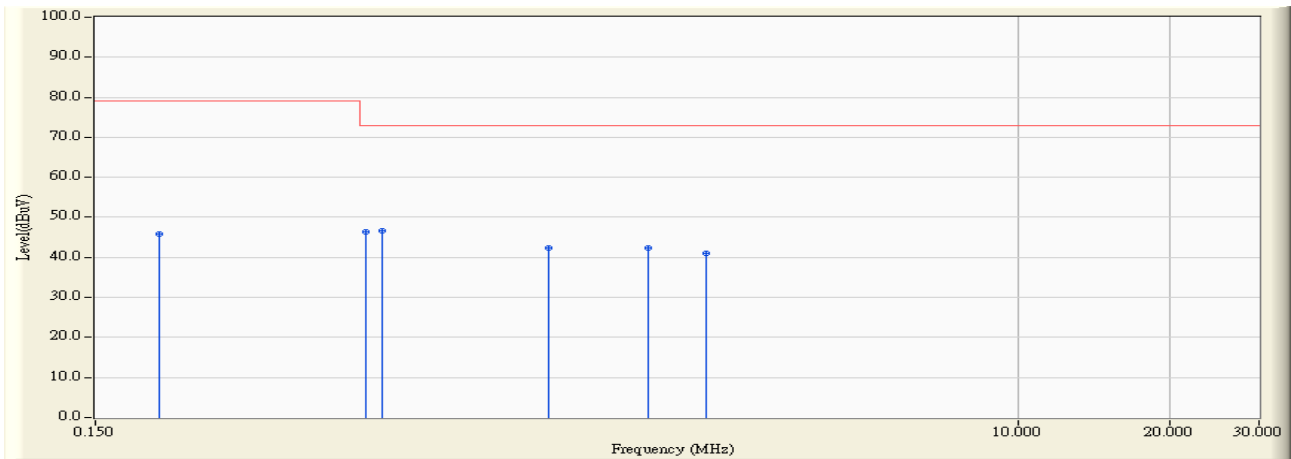

		Frequency (MHz)	Correct Factor (dB)	Reading Level (dBuV)	Measure Level (dBuV)	Margin (dB)	Limit (dBuV)	Detector Type
1		0.201	9.780	36.170	45.950	-33.050	79.000	QUASIPeAK
2		0.513	9.790	36.670	46.460	-26.540	73.000	QUASIPeAK
3	*	0.552	9.790	36.930	46.720	-26.280	73.000	QUASIPeAK
4		1.181	9.790	32.450	42.240	-30.760	73.000	QUASIPeAK
5		1.853	9.800	32.630	42.430	-30.570	73.000	QUASIPeAK
6		2.423	9.800	31.230	41.030	-31.970	73.000	QUASIPeAK

Note:

1. All Reading Levels are Quasi-Peak and average value.
2. " * ", means this data is the worst emission level.
3. Measurement Level = Reading Level + Correct Factor

Site : SR_1	Time : 2011/05/06 - 05:13
Limit : CISPR_A_00M_AV	Margin : 0
EUT : RISC-Base Industrial Ready-to-Run Embedded Computer	Probe : ENV_216_N - Line2
Power : AC 230V/50Hz	Note : Mode 1

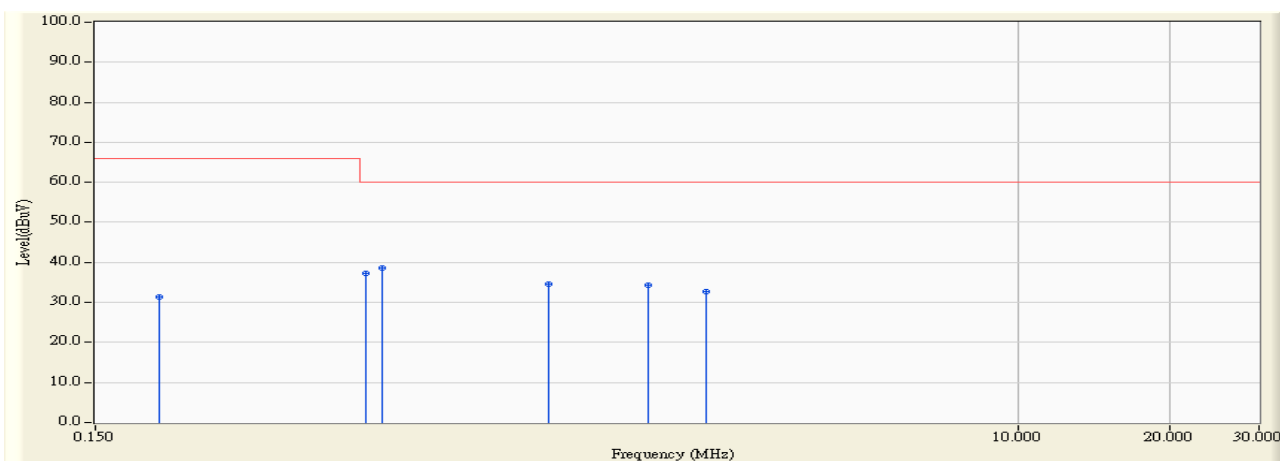

		Frequency (MHz)	Correct Factor (dB)	Reading Level (dBuV)	Measure Level (dBuV)	Margin (dB)	Limit (dBuV)	Detector Type
1		0.201	9.780	21.600	31.380	-34.620	66.000	AVERAGE
2		0.513	9.790	27.560	37.350	-22.650	60.000	AVERAGE
3	*	0.552	9.790	28.830	38.620	-21.380	60.000	AVERAGE
4		1.181	9.790	24.780	34.570	-25.430	60.000	AVERAGE
5		1.853	9.800	24.610	34.410	-25.590	60.000	AVERAGE
6		2.423	9.800	22.910	32.710	-27.290	60.000	AVERAGE

Note:

1. All Reading Levels are Quasi-Peak and average value.
2. " * ", means this data is the worst emission level.
3. Measurement Level = Reading Level + Correct Factor

3.7. Test Photograph

Test Mode : Mode 1: Normal Operation

Description : Front View of Conducted Test



Test Mode : Mode 1: Normal Operation

Description : Back View of Conducted Test



4. Conducted Emissions (Telecommunication Ports)

4.1. Test Specification

According to EMC Standard : EN 55022

4.2. Test Setup

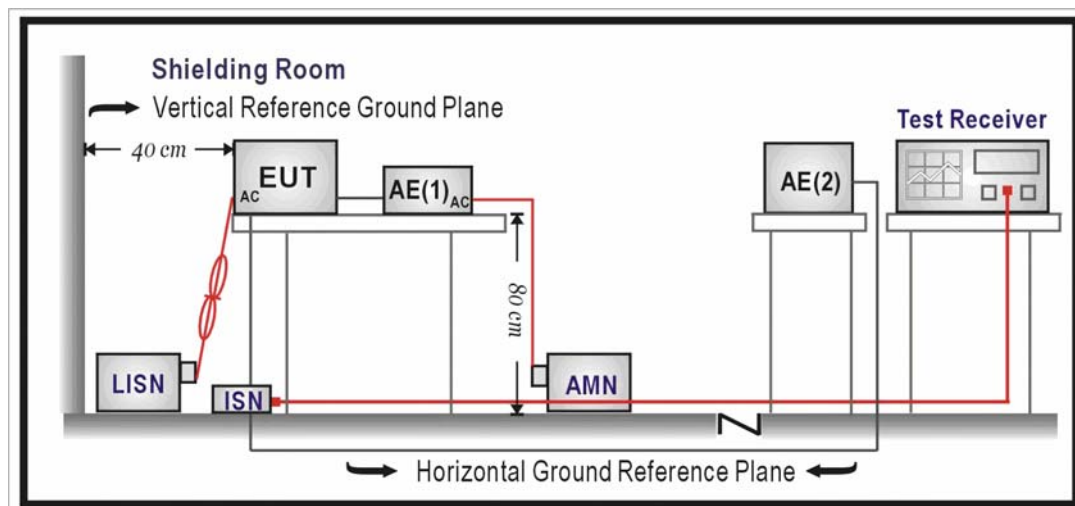

4.3. Limit

Limits		
Frequency (MHz)	QP (dBuV)	AV (dBuV)
0.15 - 0.50	97 – 87	84 – 74
0.50 - 30	87	74

Remarks:

The limit decreases linearly with the logarithm of the frequency in the range 0.15 MHz~0.50 MHz.

4.4. Test Procedure

Telecommunication Port:

The mains voltage shall be supplied to the EUT via the LISN when the measurement of telecommunication port is performed. The common mode disturbances at the telecommunication port shall be connected to the ISN, which is 150 ohm impedance.

Both alternative cables are tested related to the LCL requested. The measurement range is from 150kHz to 30MHz. The bandwidth of measurement is set to 9kHz.

The 75dB LCL ISN is used for cat. 6 cable, the 65dB LCL ISN is used for cat. 5 cable, 55dB LCL ISN is used for cat. 3.

4.5. Deviation from Test Standard

No deviation.

4.6. Test Result

Site : SR_1	Time : 2011/05/06 - 05:18
Limit : ISN_Voltage_A_00M_QP	Margin : 10
EUT : RISC-Base Industrial Ready-to-Run Embedded Computer	Probe : ISN_T4 - Line1
Power : AC 230V/50Hz	Note : Mode 1: ISN 10MB



Site : SR_1	Time : 2011/05/06 - 05:19
Limit : ISN_Voltage_A_00M_QP	Margin : 0
EUT : RISC-Base Industrial Ready-to-Run Embedded Computer	Probe : ISN_T4 - Line1
Power : AC 230V/50Hz	Note : Mode 1: ISN 10MB

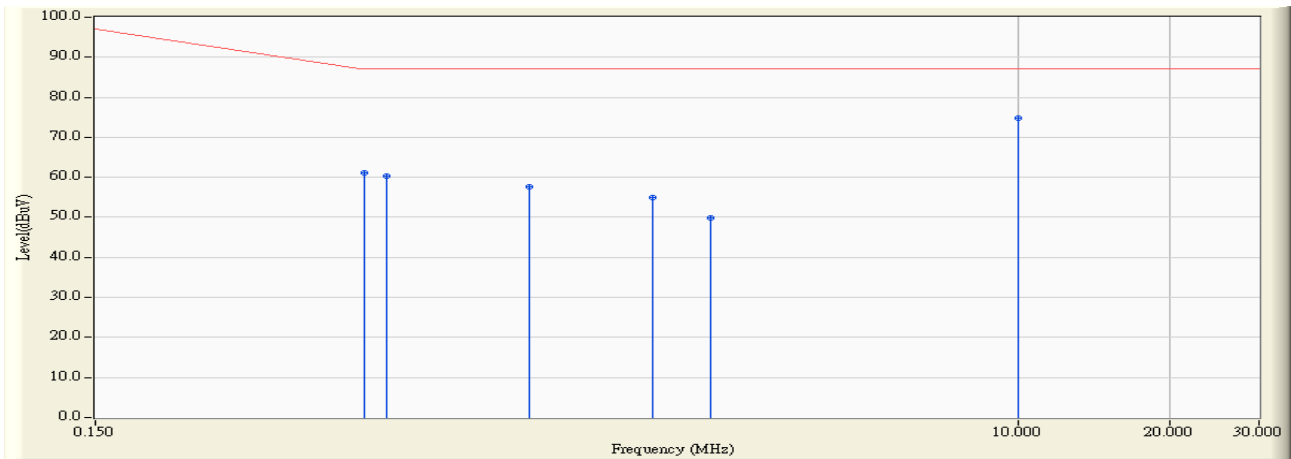

		Frequency (MHz)	Correct Factor (dB)	Reading Level (dBuV)	Measure Level (dBuV)	Margin (dB)	Limit (dBuV)	Detector Type
1		0.509	9.990	51.010	61.000	-26.000	87.000	QUASPEAK
2		0.564	9.990	50.450	60.440	-26.560	87.000	QUASPEAK
3		1.084	9.980	47.530	57.510	-29.490	87.000	QUASPEAK
4		1.892	10.000	44.950	54.950	-32.050	87.000	QUASPEAK
5		2.470	10.000	39.850	49.850	-37.150	87.000	QUASPEAK
6	*	10.002	9.960	64.950	74.910	-12.090	87.000	QUASPEAK

Note:

1. All Reading Levels are Quasi-Peak and average value.
2. " * ", means this data is the worst emission level.
3. Measurement Level = Reading Level + Correct Factor

Site : SR_1	Time : 2011/05/06 - 05:19
Limit : ISN_Voltage_A_00M_AV	Margin : 0
EUT : RISC-Base Industrial Ready-to-Run Embedded Computer	Probe : ISN_T4 - Line1
Power : AC 230V/50Hz	Note : Mode 1: ISN 10MB

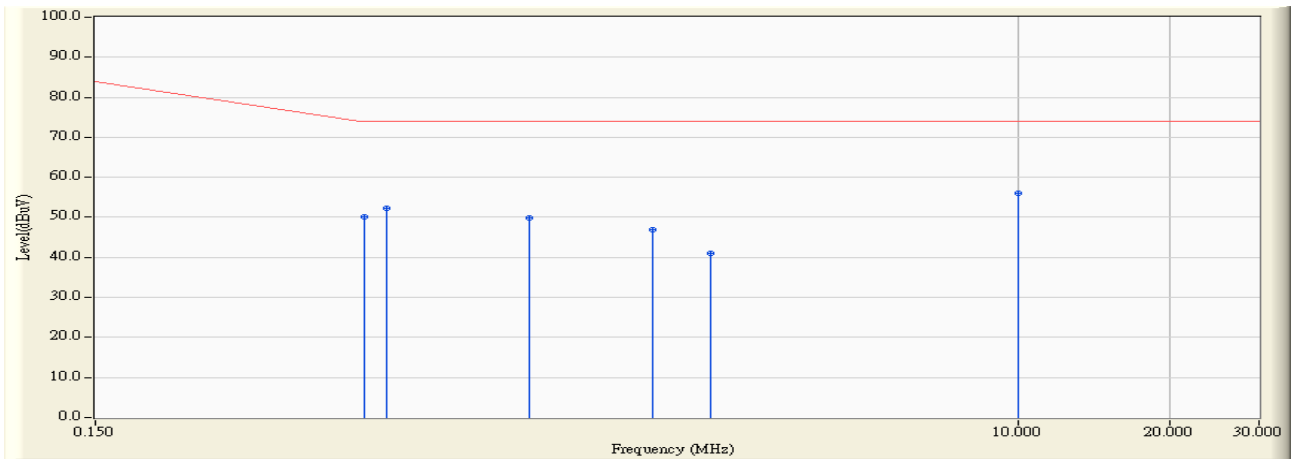

		Frequency (MHz)	Correct Factor (dB)	Reading Level (dBuV)	Measure Level (dBuV)	Margin (dB)	Limit (dBuV)	Detector Type
1		0.509	9.990	40.120	50.110	-23.890	74.000	AVERAGE
2		0.564	9.990	42.420	52.410	-21.590	74.000	AVERAGE
3		1.084	9.980	39.770	49.750	-24.250	74.000	AVERAGE
4		1.892	10.000	36.900	46.900	-27.100	74.000	AVERAGE
5		2.470	10.000	30.960	40.960	-33.040	74.000	AVERAGE
6	*	10.002	9.960	46.190	56.150	-17.850	74.000	AVERAGE

Note:

1. All Reading Levels are Quasi-Peak and average value.
2. " * ", means this data is the worst emission level.
3. Measurement Level = Reading Level + Correct Factor

Site : SR_1	Time : 2011/05/06 - 05:16
Limit : ISN_Voltage_A_00M_QP	Margin : 10
EUT : RISC-Base Industrial Ready-to-Run Embedded Computer	Probe : ISN_T4 - Line1
Power : AC 230V/50Hz	Note : Mode 1: ISN 100MB



Site : SR_1	Time : 2011/05/06 - 05:17
Limit : ISN_Voltage_A_00M_QP	Margin : 0
EUT : RISC-Base Industrial Ready-to-Run Embedded Computer	Probe : ISN_T4 - Line1
Power : AC 230V/50Hz	Note : Mode 1: ISN 100MB

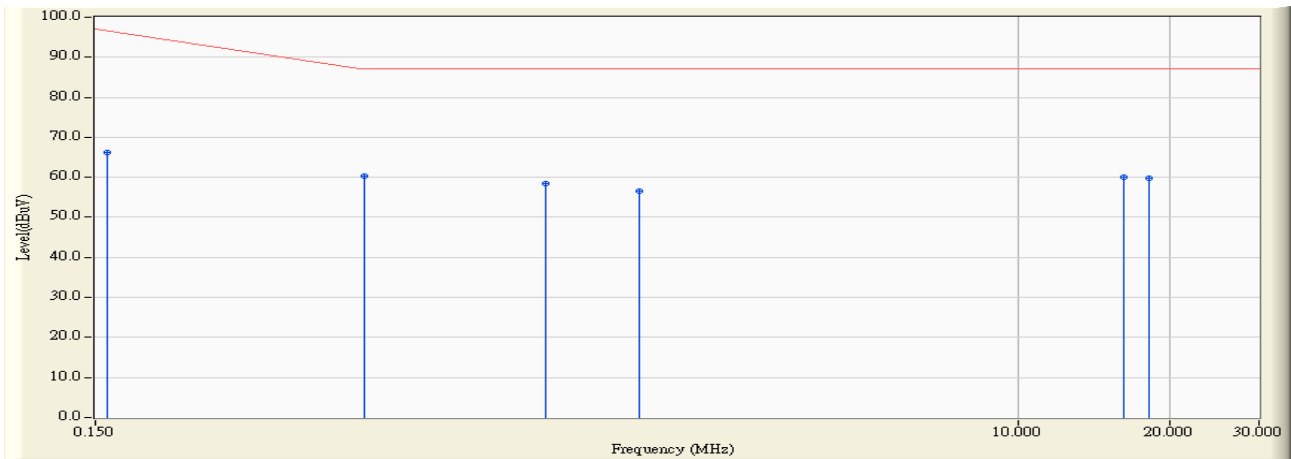

		Frequency (MHz)	Correct Factor (dB)	Reading Level (dBuV)	Measure Level (dBuV)	Margin (dB)	Limit (dBuV)	Detector Type
1		0.158	10.047	56.250	66.297	-30.474	96.771	QUASPEAK
2	*	0.509	9.990	50.250	60.240	-26.760	87.000	QUASPEAK
3		1.166	9.980	48.510	58.490	-28.510	87.000	QUASPEAK
4		1.791	10.000	46.510	56.510	-30.490	87.000	QUASPEAK
5		16.228	10.130	49.930	60.060	-26.940	87.000	QUASPEAK
6		18.244	10.120	49.770	59.890	-27.110	87.000	QUASPEAK

Note:

1. All Reading Levels are Quasi-Peak and average value.
2. " * ", means this data is the worst emission level.
3. Measurement Level = Reading Level + Correct Factor

Site : SR_1	Time : 2011/05/06 - 05:17
Limit : ISN_Voltage_A_00M_AV	Margin : 0
EUT : RISC-Base Industrial Ready-to-Run Embedded Computer	Probe : ISN_T4 - Line1
Power : AC 230V/50Hz	Note : Mode 1: ISN 100MB

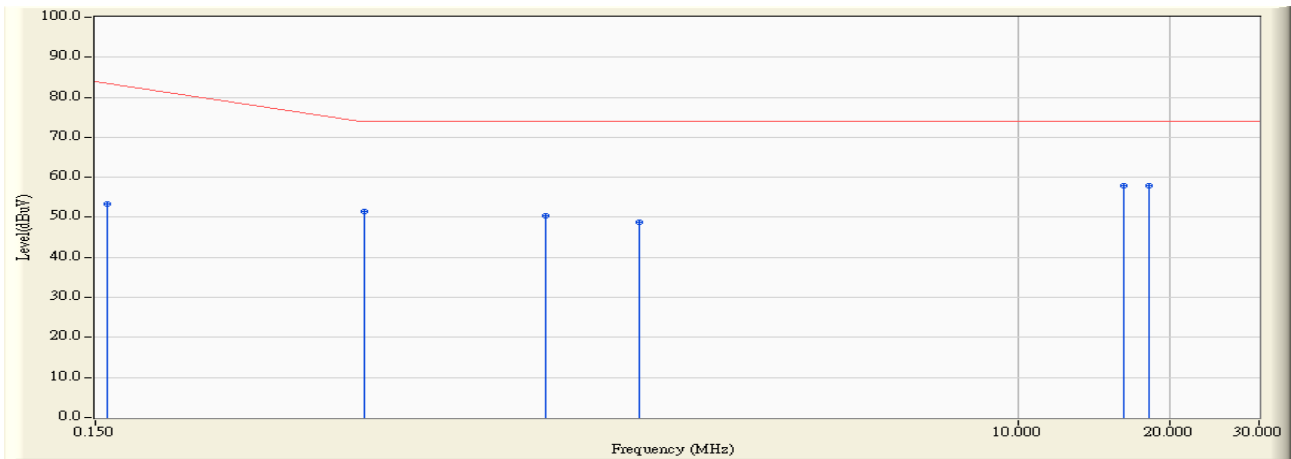

		Frequency (MHz)	Correct Factor (dB)	Reading Level (dBuV)	Measure Level (dBuV)	Margin (dB)	Limit (dBuV)	Detector Type
1		0.158	10.047	43.240	53.287	-30.484	83.771	AVERAGE
2		0.509	9.990	41.560	51.550	-22.450	74.000	AVERAGE
3		1.166	9.980	40.450	50.430	-23.570	74.000	AVERAGE
4		1.791	10.000	38.790	48.790	-25.210	74.000	AVERAGE
5	*	16.228	10.130	47.810	57.940	-16.060	74.000	AVERAGE
6		18.244	10.120	47.720	57.840	-16.160	74.000	AVERAGE

Note:

1. All Reading Levels are Quasi-Peak and average value.
2. " * ", means this data is the worst emission level.
3. Measurement Level = Reading Level + Correct Factor

4.7. Test Photograph

Test Mode : Mode 1: Normal Operation

Description : Front View of ISN Test



Test Mode : Mode 1: Normal Operation

Description : Back View of ISN Test



5. Radiated Emission

5.1. Test Specification

According to EMC Standard : EN 55022

5.2. Test Setup

Under 1GHz Test Setup:

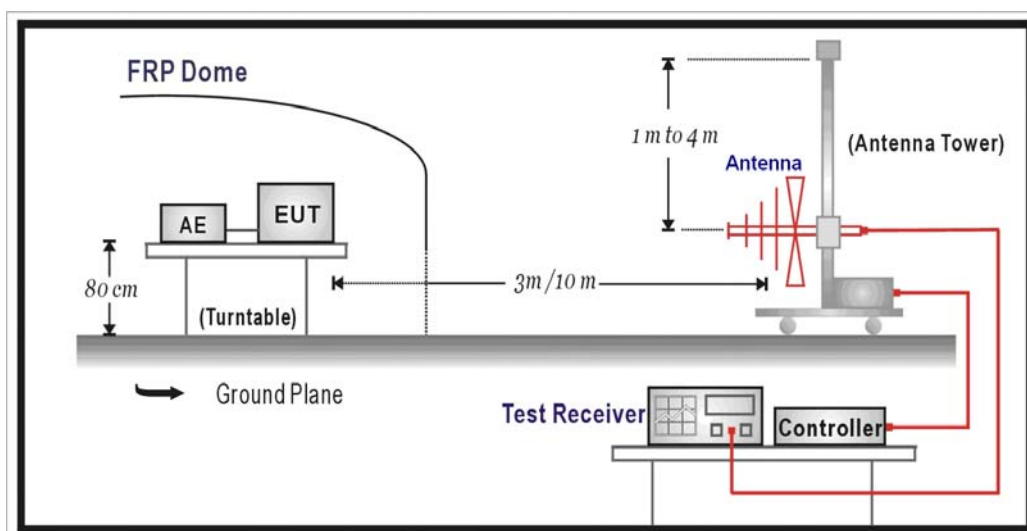

Above 1GHz Test Setup:

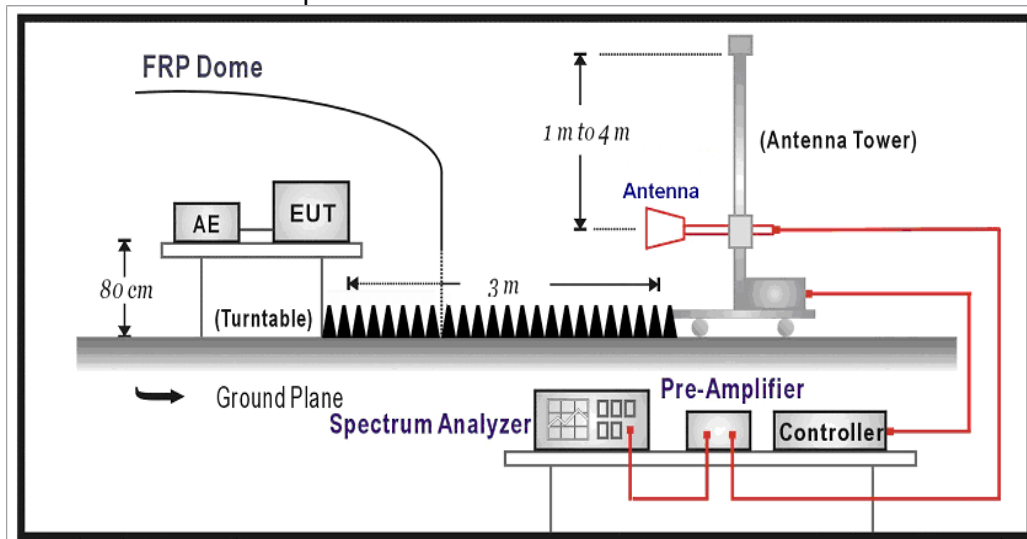

5.3. Limit

Limits		
Frequency MHz	Distance (m)	dBuV/m
30 – 230	10	40
230 – 1000	10	47

Limits			
Frequency (GHz)	Distance (m)	Peak (dBuV/m)	Average (dBuV/m)
1 – 3	3	76	56
3 – 6	3	80	60

Remark:

1. The tighter limit shall apply at the edge between two frequency bands.
2. Distance refers to the distance in meters between the measuring instrument antenna and the closed point of any part of the device or system.

Highest frequency generated or used in the device or on which the device operates or tunes (MHz)	Upper frequency of measurement range (MHz)
Below 108	1000
108 – 500	2000
500 – 1000	5000
Above 1000	5 th harmonic of the highest frequency or 6 GHz, whichever is lower

5.4. Test Procedure

The EUT and its simulators are placed on a turn table which is 0.8 meter above ground. The turn table can rotate 360 degrees to determine the position of the maximum emission level. The EUT was positioned such that the distance from antenna to the EUT was 3/10 meters. The antenna can move up and down between 1 meter and 4 meters to find out the maximum emission level.

Both horizontal and vertical polarization of the antenna are set on measurement. In order to find the maximum emission, all of the interface cables must be manipulated on radiated measurement.

Radiated emissions were investigated over the frequency range from 30MHz to 1GHz using a receiver bandwidth of 120kHz and above 1GHz using a receiver bandwidth of 1MHz.

30MHz to 1GHz Radiated was performed at an antenna to EUT distance of 10 meters.

Above 1GHz Radiated was performed at an antenna to EUT distance of 3 meters.

It is placed with absorb on the ground between EUT and Antenna.

5.5. Deviation from Test Standard

No deviation.

5.6. Test Result

Site : OATS-1	Time : 2011/05/04 - 23:33
Limit : CISPR_A_10M_QP	Margin : 6
EUT : RISC-Base Industrial Ready-to-Run Embedded Computer	Probe : Site1_CBL6112_10M_0811 - HORIZONTAL
Power : AC 230V / 50Hz	Note : Mode 1

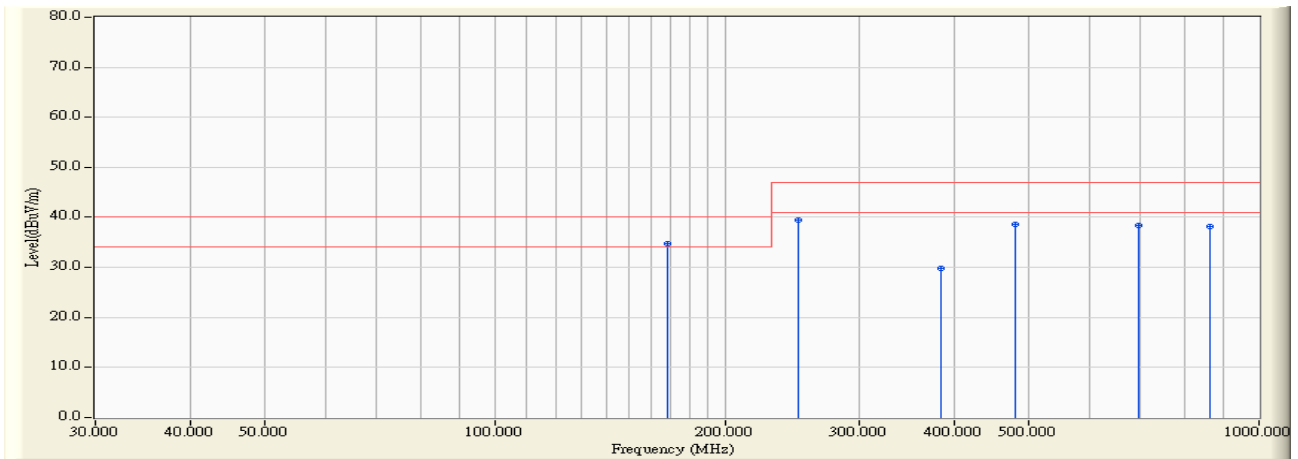

		Frequency (MHz)	Correct Factor (dB)	Reading Level (dBuV)	Measure Level (dBuV/m)	Margin (dB)	Limit (dBuV/m)	Detector Type
1	*	168.000	11.295	23.500	34.795	-5.205	40.000	QUASIPeAK
2		250.000	14.388	25.100	39.488	-7.512	47.000	QUASIPeAK
3		384.000	18.591	11.300	29.891	-17.109	47.000	QUASIPeAK
4		480.000	20.693	17.900	38.593	-8.407	47.000	QUASIPeAK
5		696.000	23.242	15.100	38.342	-8.658	47.000	QUASIPeAK
6		864.000	25.163	13.100	38.263	-8.737	47.000	QUASIPeAK

Note:

1. All Readings below 1GHz are Quasi-Peak, above are performed with peak and/or average measurements as necessary.
2. " * ", means this data is the worst emission level.
3. Measurement Level = Reading Level + Correct Factor

Site : OATS-1	Time : 2011/05/04 - 23:29
Limit : CISPR_A_10M_QP	Margin : 6
EUT : RISC-Base Industrial Ready-to-Run Embedded Computer	Probe : Site1_CBL6112_10M_0811 - VERTICAL
Power : AC 230V / 50Hz	Note : Mode 1

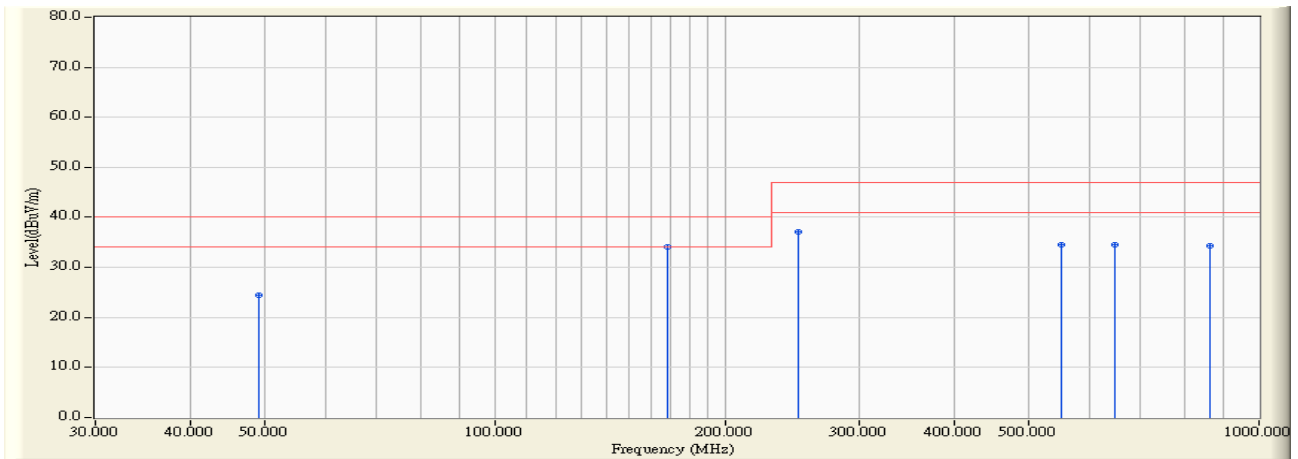

		Frequency (MHz)	Correct Factor (dB)	Reading Level (dBuV)	Measure Level (dBuV/m)	Margin (dB)	Limit (dBuV/m)	Detector Type
1		49.000	9.553	15.000	24.553	-15.447	40.000	QUASIPeAK
2	*	167.984	11.296	22.900	34.196	-5.804	40.000	QUASIPeAK
3		250.000	14.388	22.700	37.088	-9.912	47.000	QUASIPeAK
4		552.000	22.661	11.800	34.461	-12.539	47.000	QUASIPeAK
5		648.000	22.949	11.600	34.549	-12.451	47.000	QUASIPeAK
6		864.000	25.163	9.100	34.263	-12.737	47.000	QUASIPeAK

Note:

1. All Readings below 1GHz are Quasi-Peak, above are performed with peak and/or average measurements as necessary.
2. " * ", means this data is the worst emission level.
3. Measurement Level = Reading Level + Correct Factor

5.7. Test Photograph

Test Mode : Mode 1: Normal Operation

Description : Front View of Radiated Test



Test Mode : Mode 1: Normal Operation

Description : Back View of Radiated Test



6. Harmonic Current Emission

6.1. Test Specification

According to EMC Standard : EN 61000-3-2

6.2. Test Setup

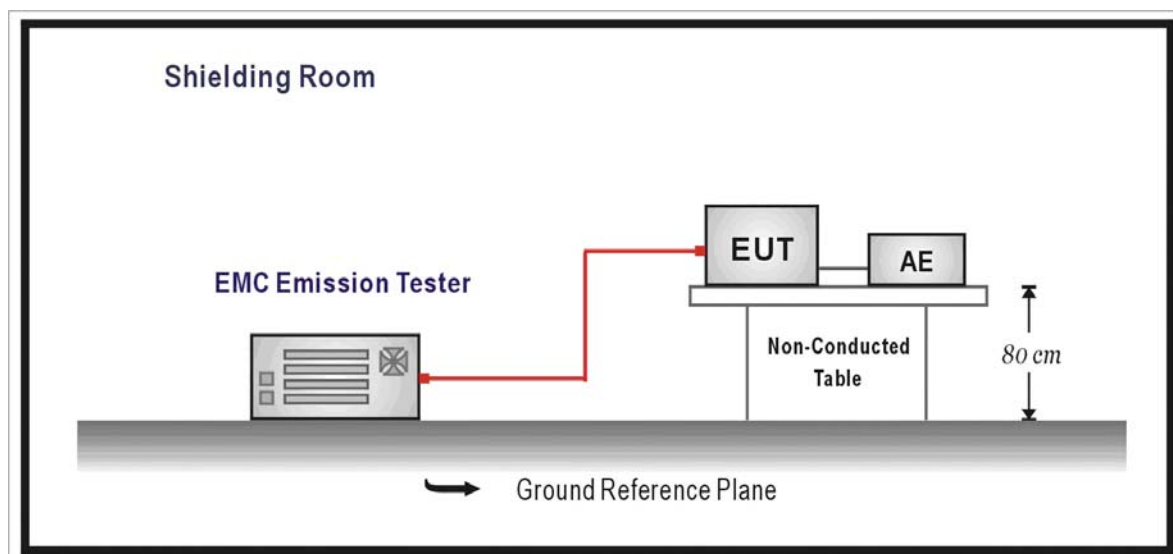

6.3. Limit

(a) Limits of Class A Harmonics Currents

Harmonics Order n	Maximum Permissible harmonic current A	Harmonics Order n	Maximum Permissible harmonic current A
Odd harmonics		Even harmonics	
3	2.30	2	1.08
5	1.14	4	0.43
7	0.77	6	0.30
9	0.40	8 ≤ n ≤ 40	0.23 * 8/n
11	0.33		
13	0.21		
15 ≤ n ≤ 39	0.15 * 15/n		

(b) Limits of Class B Harmonics Currents

For Class B equipment, the harmonic of the input current shall not exceed the maximum permissible values given in table that is the limit of Class A multiplied by a factor of 1.5.

(c) Limits of Class C Harmonics Currents

Harmonics Order n	Maximum Permissible harmonic current Expressed as a percentage of the input current at the fundamental frequency %
2	2
3	$30 \cdot \lambda^*$
5	10
7	7
9	5
$11 \leq n \leq 39$ (odd harmonics only)	3

* λ is the circuit power factor

(d) Limits of Class D Harmonics Currents

Harmonics Order n	Maximum Permissible harmonic current per watt mA/W	Maximum Permissible harmonic current A
3	3.4	2.30
5	1.9	1.14
7	1.0	0.77
9	0.5	0.40
11	0.35	0.33
$11 \leq n \leq 39$ (odd harmonics only)	$3.85/n$	See limit of Class A

6.4. Test Procedure

The EUT is supplied in series with power analyzer from a power source having the same normal voltage and frequency as the rated supply voltage and the equipment under test. And the rated voltage at the supply voltage of EUT of 0.94 times and 1.06 times shall be performed.

6.5. Deviation from Test Standard

No deviation.

6.6. Test Result

Product	RISC-Base Industrial Ready-to-Run Embedded Computer		
Test Item	Power Harmonics		
Test Mode	Mode 1: Normal Operation		
Date of Test	2011/05/06	Test Site	No.3 Shielded Room

Test Result: Pass Source qualification: Normal

Current & voltage waveforms

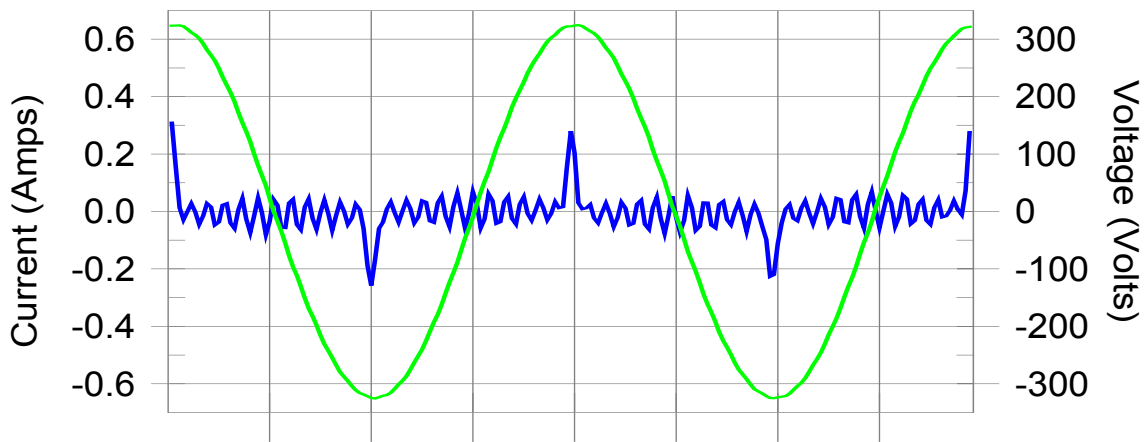

Harmonics and Class A limit line

European Limits

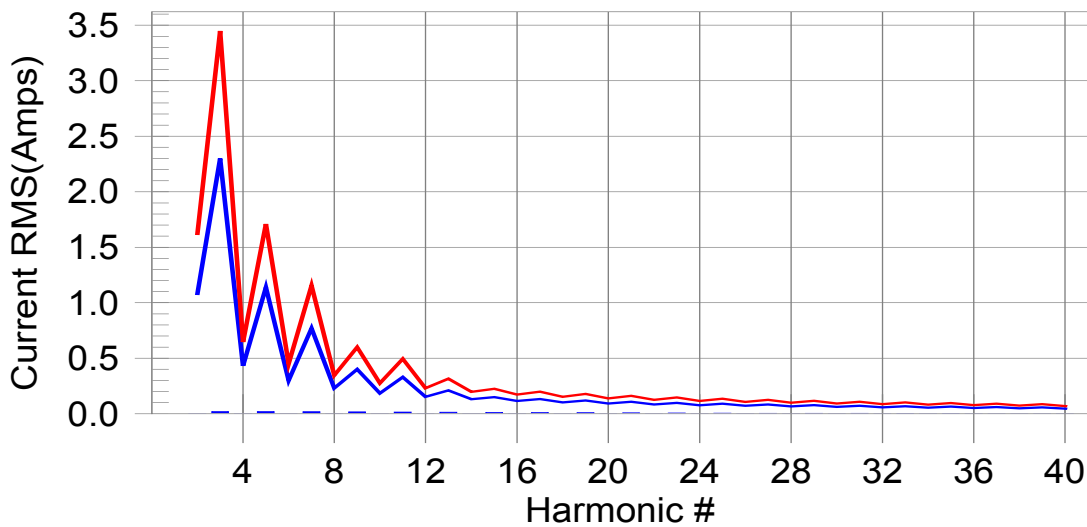

Test result: Pass Worst harmonic was #15 with 8.13% of the limit.

Test Result: Pass Source qualification: Normal
 THC(A): 0.05 I-THD(%): 224.53 POHC(A): 0.014 POHC Limit(A): 0.251
 Highest parameter values during test:

V_RMS (Volts):	229.63	Frequency(Hz):	50.00
I_Peak (Amps):	0.337	I_RMS (Amps):	0.064
I_Fund (Amps):	0.022	Crest Factor:	5.317
Power (Watts):	4.7	Power Factor:	0.322

Harm#	Harms(avg)	100%Limit	%of Limit	Harms(max)	150%Limit	%of Limit	Status
2	0.001	1.080	0.1	0.001	1.620	0.04	Pass
3	0.019	2.300	0.8	0.020	3.450	0.57	Pass
4	0.001	0.430	0.1	0.001	0.645	0.11	Pass
5	0.019	1.140	1.6	0.019	1.710	1.12	Pass
6	0.001	0.300	0.2	0.001	0.450	0.18	Pass
7	0.018	0.770	2.3	0.018	1.155	1.57	Pass
8	0.001	0.230	0.3	0.001	0.345	0.20	Pass
9	0.017	0.400	4.1	0.017	0.600	2.81	Pass
10	0.001	0.184	0.3	0.001	0.276	0.25	Pass
11	0.015	0.330	4.6	0.015	0.495	3.13	Pass
12	0.001	0.153	0.4	0.001	0.230	0.32	Pass
13	0.014	0.210	6.5	0.014	0.315	4.43	Pass
14	0.001	0.131	0.5	0.001	0.197	0.34	Pass
15	0.012	0.150	8.1	0.012	0.225	5.50	Pass
16	0.001	0.115	0.5	0.001	0.173	0.37	Pass
17	0.011	0.132	8.1	0.011	0.199	5.46	Pass
18	0.001	0.102	0.5	0.001	0.153	0.42	Pass
19	0.009	0.118	7.8	0.009	0.178	5.28	Pass
20	0.000	0.092	0.5	0.001	0.138	0.41	Pass
21	0.008	0.107	7.4	0.008	0.161	4.98	Pass
22	0.000	0.084	0.6	0.001	0.125	0.42	Pass
23	0.007	0.098	6.8	0.007	0.147	4.63	Pass
24	0.000	0.077	0.5	0.000	0.115	0.42	Pass
25	0.006	0.090	6.3	0.006	0.135	4.24	Pass
26	0.000	0.071	0.5	0.000	0.106	0.42	Pass
27	0.005	0.083	5.6	0.005	0.125	3.82	Pass
28	0.000	0.066	0.5	0.000	0.099	0.40	Pass
29	0.004	0.078	5.0	0.004	0.116	3.41	Pass
30	0.000	0.061	0.5	0.000	0.092	0.40	Pass
31	0.003	0.073	4.4	0.003	0.109	2.98	Pass
32	0.000	0.058	0.4	0.000	0.086	0.37	Pass
33	0.003	0.068	3.8	0.003	0.102	2.59	Pass
34	0.000	0.054	0.4	0.000	0.081	0.36	Pass
35	0.002	0.064	3.2	0.002	0.096	2.20	Pass
36	0.000	0.051	0.4	0.000	0.077	0.36	Pass
37	0.002	0.061	2.6	0.002	0.091	1.80	Pass
38	0.000	0.048	0.4	0.000	0.073	0.34	Pass
39	0.001	0.058	2.0	0.001	0.087	1.44	Pass
40	0.000	0.046	0.4	0.000	0.069	0.34	Pass

1.Dynamic limits were applied for this test. The highest harmonics values in the above table may not occur at the same window as the maximum harmonics/limit ratio.

2:According to EN61000-3-2 paragraph 7 the note 1 and 2 are valid for all applications having an active input power >75W. Others the result should be pass.

6.7. Test Photograph

Test Mode : Mode 1: Normal Operation

Description : Power Harmonics Test Setup



7. Voltage Fluctuation and Flicker

7.1. Test Specification

According to EMC Standard : EN 61000-3-3

7.2. Test Setup

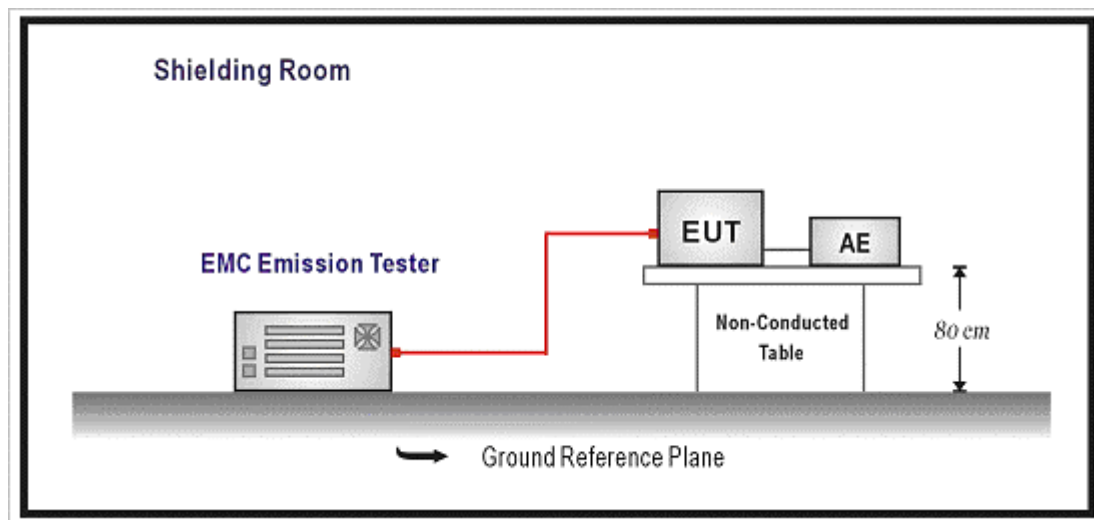

7.3. Limit

The following limits apply:

- the value of P_{st} shall not be greater than 1.0;
- the value of P_{1t} shall not be greater than 0.65;
- the value of $d(t)$ during a voltage change shall not exceed 3.3 % for more than 500 ms;
- the relative steady-state voltage change, d_c , shall not exceed 3.3 %;
- the maximum relative voltage change, d_{max} , shall not exceed;
 - a) 4 % without additional conditions;
 - b) 6 % for equipment which is:
 - switched manually, or
 - switched automatically more frequently than twice per day, and also has either a delayed restart (the delay being not less than a few tens of seconds), or manual restart, after a power supply interruption.

NOTE The cycling frequency will be further limited by the P_{st} and P_{1t} limit.

For example: a d_{max} of 6% producing a rectangular voltage change characteristic twice per hour will give a P_{1t} of about 0.65.

- c) 7 % for equipment which is:
- attended whilst in use (for example: hair dryers, vacuum cleaners, kitchen equipment such as mixers, garden equipment such as lawn mowers, portable tools such as electric drills), or
 - switched on automatically, or is intended to be switched on manually, no more than twice per day, and also has either a delayed restart (the delay being not less than a few tens of seconds) or manual restart, after a power supply interruption.

P_{st} and P_{1t} requirements shall not be applied to voltage changes caused by manual switching.

7.4. Test Procedure

The EUT is supplied in series with power analyzer from a power source having the same normal voltage and frequency as the rated supply voltage and the equipment under test. And the rated voltage at the supply voltage of EUT of 0.94 times and 1.06 times shall be performed.

7.5. Deviation from Test Standard

No deviation.

7.6. Test Result

Product	RISC-Base Industrial Ready-to-Run Embedded Computer		
Test Item	Voltage Fluctuation and Flicker		
Test Mode	Mode 1: Normal Operation		
Date of Test	2011/05/06	Test Site	No.3 Shielded Room

Test Result: Pass

Status: Test Completed

Pstj and limit line

European Limits

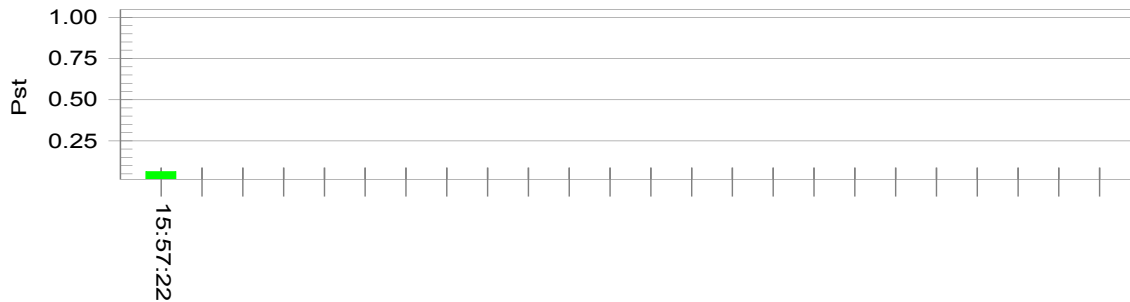

Plt and limit line

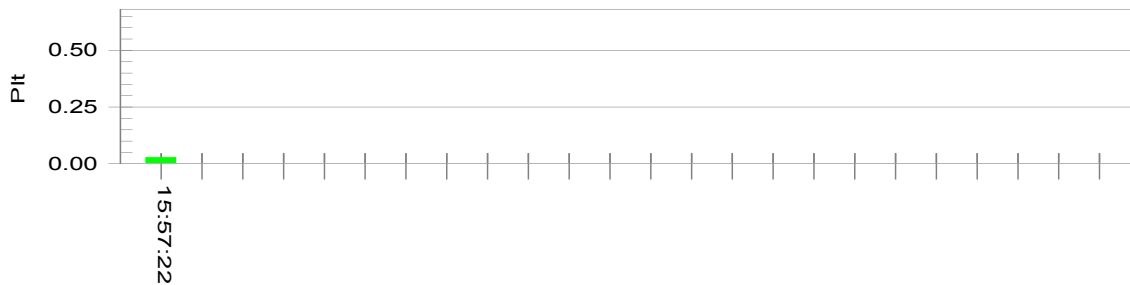

Parameter values recorded during the test:

Vrms at the end of test (Volt):	229.55		
Highest dt (%):	0.00	Test limit (%):	3.30 Pass
Time(mS) > dt:	0.0	Test limit (mS):	500.0 Pass
Highest dc (%):	0.00	Test limit (%):	3.30 Pass
Highest dmax (%):	0.00	Test limit (%):	4.00 Pass
Highest Pst (10 min. period):	0.064	Test limit:	1.000 Pass
Highest Plt (2 hr. period):	0.028	Test limit:	0.650 Pass

7.7. Test Photograph

Test Mode : Mode 1: Normal Operation

Description : Flicker Test Setup



8. Electrostatic Discharge

8.1. Test Specification

According to Standard : IEC 61000-4-2

8.2. Test Setup

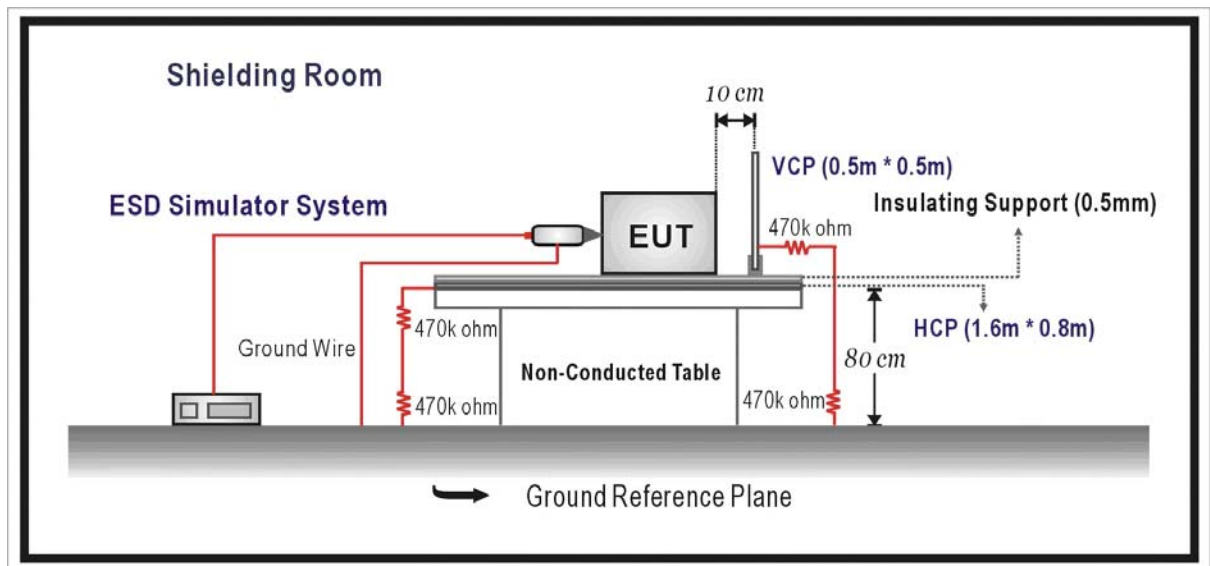

8.3. Limit

Item	Environmental Phenomena	Units	Test Specification	Performance Criteria
Enclosure Port				
	Electrostatic Discharge	kV(Charge Voltage)	±8 Air Discharge ±4 Contact Discharge	B

8.4. Test Procedure

Direct application of discharges to the EUT:

Contact discharge was applied only to conductive surfaces of the EUT.

Air discharges were applied only to non-conductive surfaces of the EUT.

During the test, it was performed with single discharges. For the single discharge time between successive single discharges will be keep longer 1 second. It was at least ten single discharges with positive and negative at the same selected point.

The selected point, which was performed with electrostatic discharge, was marked on the red label of the EUT.

Indirect application of discharges to the EUT:

Vertical Coupling Plane (VCP):

The coupling plane, of dimensions 0.5m x 0.5m, is placed parallel to, and positioned at a distance 0.1m from, the EUT, with the Discharge Electrode touching the coupling plane.

The four faces of the EUT will be performed with electrostatic discharge. It was at least ten single discharges with positive and negative at the same selected point.

Horizontal Coupling Plane (HCP):

The coupling plane is placed under to the EUT. The generator shall be positioned vertically at a distance of 0.1m from the EUT, with the Discharge Electrode touching the coupling plane.

The four faces of the EUT will be performed with electrostatic discharge. It was at least ten single discharges with positive and negative at the same selected point.

8.5. Deviation from Test Standard

No deviation.

8.6. Test Result

Product	RISC-Base Industrial Ready-to-Run Embedded Computer		
Test Item	Electrostatic Discharge		
Test Mode	Mode 1: Normal Operation		
Date of Test	2011/05/10	Test Site	No.6 Shielded Room

Item	Amount of Discharge	Voltage	Required Criteria	Complied To Criteria (A,B,C)	Results
Air Discharge	10	+8kV	B	A	Pass
	10	-8kV	B	A	Pass
Contact Discharge	25	+4kV	B	A	Pass
	25	-4kV	B	A	Pass
Indirect Discharge (HCP)	25	+4kV	B	A	Pass
	25	-4kV	B	A	Pass
Indirect Discharge (VCP Front)	25	+4kV	B	A	Pass
	25	-4kV	B	A	Pass
Indirect Discharge (VCP Left)	25	+4kV	B	A	Pass
	25	-4kV	B	A	Pass
Indirect Discharge (VCP Back)	25	+4kV	B	A	Pass
	25	-4kV	B	A	Pass
Indirect Discharge (VCP Right)	25	+4kV	B	A	Pass
	25	-4kV	B	A	Pass

Note:

The testing performed is from lowest level up to the highest level as required by standard, but only highest level is shown on the report.

NR: No Requirement

- Meet criteria A: Operate as intended during and after the test
- Meet criteria B: Operate as intended after the test
- Meet criteria C: Loss/Error of function
- Additional Information
 - EUT stopped operation and could / could not be reset by operator at ____ kV.
 - No false alarms or other malfunctions were observed during or after the test.

Remark:

The Contact discharges were applied at least total 200 discharges at a minimum of four test points.

8.7. Test Photograph

Test Mode : Mode 1: Normal Operation

Description : ESD Test Setup



9. Radiated Susceptibility

9.1. Test Specification

According to Standard : IEC 61000-4-3

9.2. Test Setup

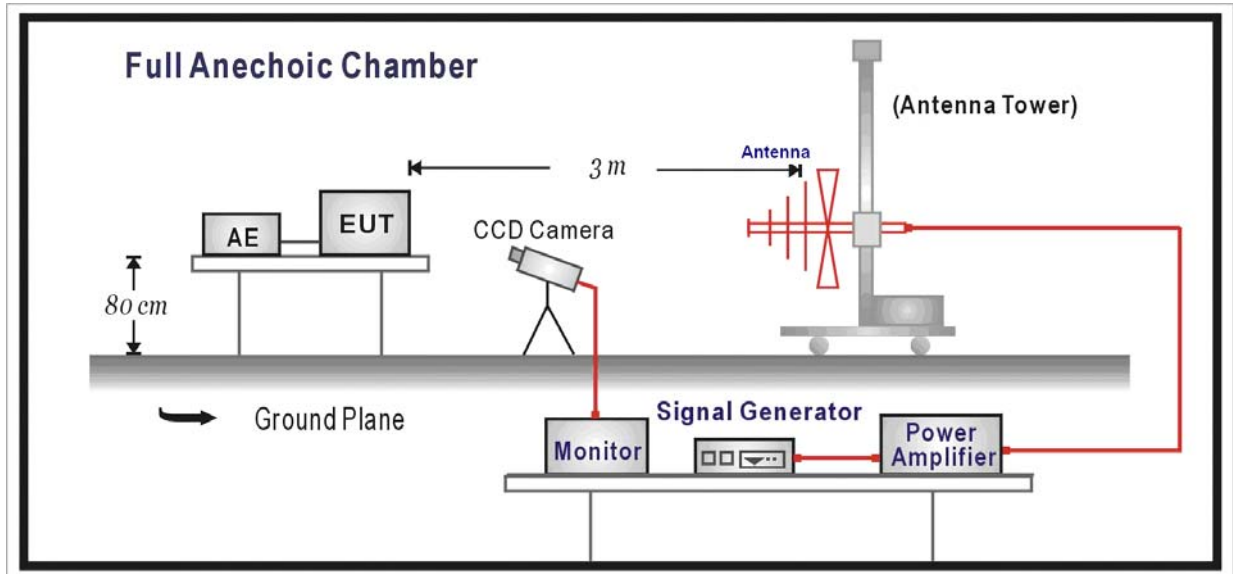

9.3. Limit

Item	Environmental Phenomena	Units	Test Specification	Performance Criteria
Enclosure Port				
	Radio-Frequency Electromagnetic Field Amplitude Modulated	MHz V/m(Un-modulated, rms) % AM (1kHz)	80-1000 3 80	A

9.4. Test Procedure

The EUT and load, which are placed on a table that is 0.8 meter above ground, are placed with one coincident with the calibration plane such that the distance from antenna to the EUT was 3 meters.

Both horizontal and vertical polarization of the antenna and four sides of the EUT are set on measurement.

In order to judge the EUT performance, a CCD camera is used to monitor EUT screen.

All the scanning conditions are as follows:

Condition of Test	Remarks
1. Field Strength	3 V/m Level 2
2. Radiated Signal	AM 80% Modulated with 1kHz
3. Scanning Frequency	80MHz - 1000MHz
4. Dwell Time	3 Seconds
5. Frequency step size Δf :	1%
6. The rate of Swept of Frequency	1.5×10^{-3} decades/s

9.5. Deviation from Test Standard

No deviation.

9.6. Test Result

Product	RISC-Base Industrial Ready-to-Run Embedded Computer		
Test Item	Radiated susceptibility		
Test Mode	Mode 1: Normal Operation		
Date of Test	2011/05/09	Test Site	Chamber5

Frequency (MHz)	Position (Angle)	Polarity (H or V)	Field Strength (V/m)	Required Criteria	Complied To Criteria (A,B,C)	Results
80-1000	FRONT	H	3	A	A	PASS
80-1000	FRONT	V	3	A	A	PASS
80-1000	BACK	H	3	A	A	PASS
80-1000	BACK	V	3	A	A	PASS
80-1000	RIGHT	H	3	A	A	PASS
80-1000	RIGHT	V	3	A	A	PASS
80-1000	LEFT	H	3	A	A	PASS
80-1000	LEFT	V	3	A	A	PASS
80-1000	UP	H	3	A	A	PASS
80-1000	UP	V	3	A	A	PASS
80-1000	DOWN	H	3	A	A	PASS
80-1000	DOWN	V	3	A	A	PASS
895-905	All Face	H	3	A	A	PASS
895-905	All Face	V	3	A	A	PASS
1795-1805	All Face	H	3	A	A	PASS
1795-1805	All Face	V	3	A	A	PASS

Note:

The testing performed is from lowest level up to the highest level as required by standard, but only highest level is shown on the report.

- Meet criteria A: Operate as intended during and after the test
- Meet criteria B: Operate as intended after the test
- Meet criteria C: Loss/Error of function
- Additional Information
 - There was no observable degradation in performance.
 - EUT stopped operation and could / could not be reset by operator at _____ V/m at frequency _____ MHz.
- No false alarms or other malfunctions were observed during or after the test.

9.7. Test Photograph

Test Mode : Mode 1: Normal Operation

Description : Radiated Susceptibility Test Setup

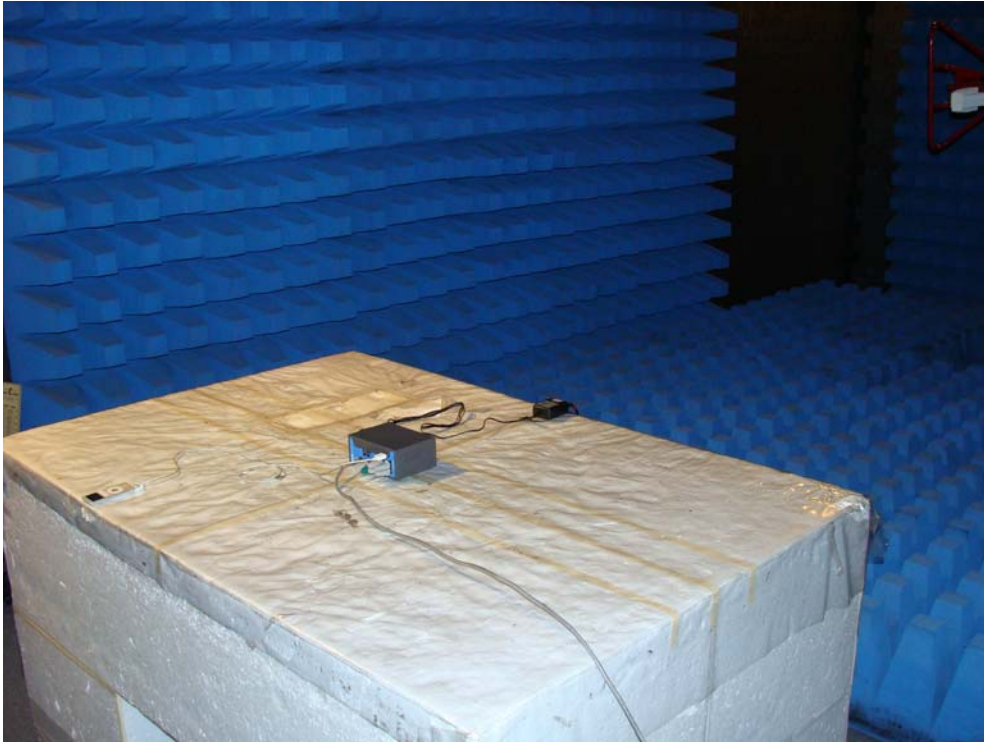

10. Electrical Fast Transient/Burst

10.1. Test Specification

According to Standard : IEC 61000-4-4

10.2. Test Setup

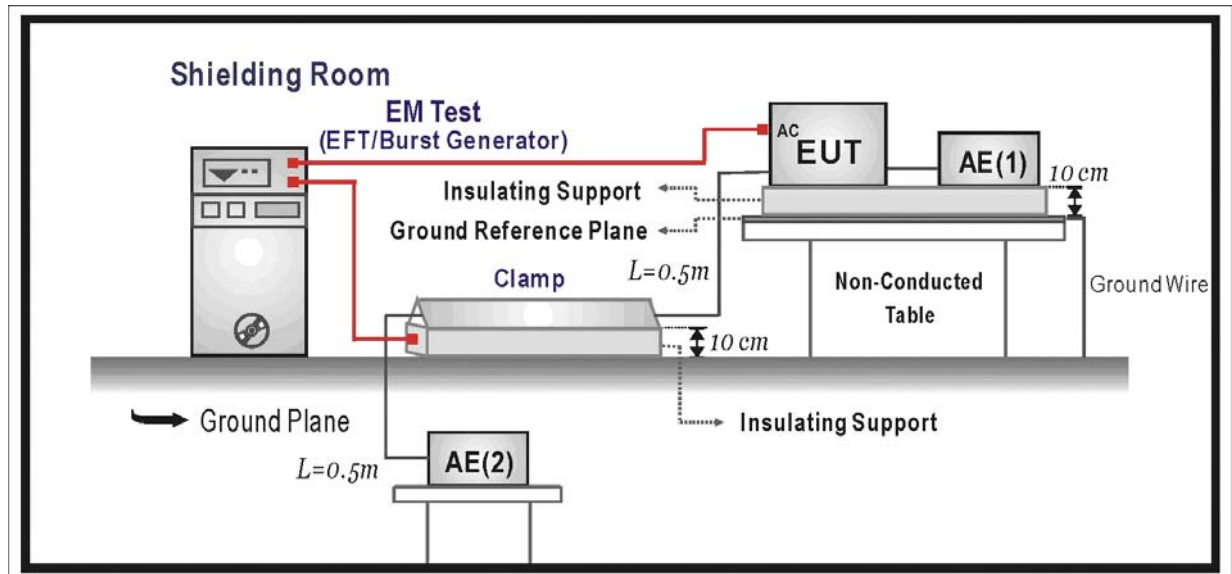

10.3. Limit

Item	Environmental Phenomena	Units	Test Specification	Performance Criteria
I/O and communication ports				
	Fast Transients Common Mode	kV (Peak) Tr/Th ns Rep. Frequency kHz	+0.5 5/50 5	B
Input DC Power Ports				
	Fast Transients Common Mode	kV (Peak) Tr/Th ns Rep. Frequency kHz	+0.5 5/50 5	B
Input AC Power Ports				
	Fast Transients Common Mode	kV (Peak) Tr/Th ns Rep. Frequency kHz	+1 5/50 5	B

10.4. Test Procedure

The EUT is placed on a table that is 0.8 meter height. A ground reference plane is placed on the table, and uses a 0.1m insulation between the EUT and ground reference plane.

The minimum area of the ground reference plane is 1m*1m, and 0.65mm thick min, and projected beyond the EUT by at least 0.1m on all sides.

Test on I/O and communication ports:

The EFT interference signal is through a coupling clamp device couples to the signal and control lines of the EUT with burst noise for 1minute.

Test on power supply ports:

The EUT is connected to the power mains through a coupling device that directly couples the EFT/B interference signal.

Each of the Line and Neutral conductors is impressed with burst noise for 1 minute.

The length of the signal and power lines between the coupling device and the EUT is 0.5m.

10.5. Deviation from Test Standard

No deviation.

10.6. Test Result

Product	RISC-Base Industrial Ready-to-Run Embedded Computer		
Test Item	Electrical fast transient/burst		
Test Mode	Mode 1: Normal Operation		
Date of Test	2011/05/09	Test Site	No.3 Shielded Room

Inject Line	Polarity	Voltage kV	Inject Time (Second)	Inject Method	Required Criteria	Complied to Criteria	Result
L+N	±	1kV	60	Direct	B	A	PASS
Communication	±	0.5kV	60	Clamp	B	A	PASS

Note:

The testing performed is from lowest level up to the highest level as required by standard, but only highest level is shown on the report.

- Meet criteria A : Operate as intended during and after the test
- Meet criteria B : Operate as intended after the test
- Meet criteria C : Loss/Error of function
- Additional Information
 - EUT stopped operation and could / could not be reset by operator at _____ kV of Line _____.
- No false alarms or other malfunctions were observed during or after the test.

10.7. Test Photograph

Test Mode : Mode 1: Normal Operation

Description : EFT/B Test Setup

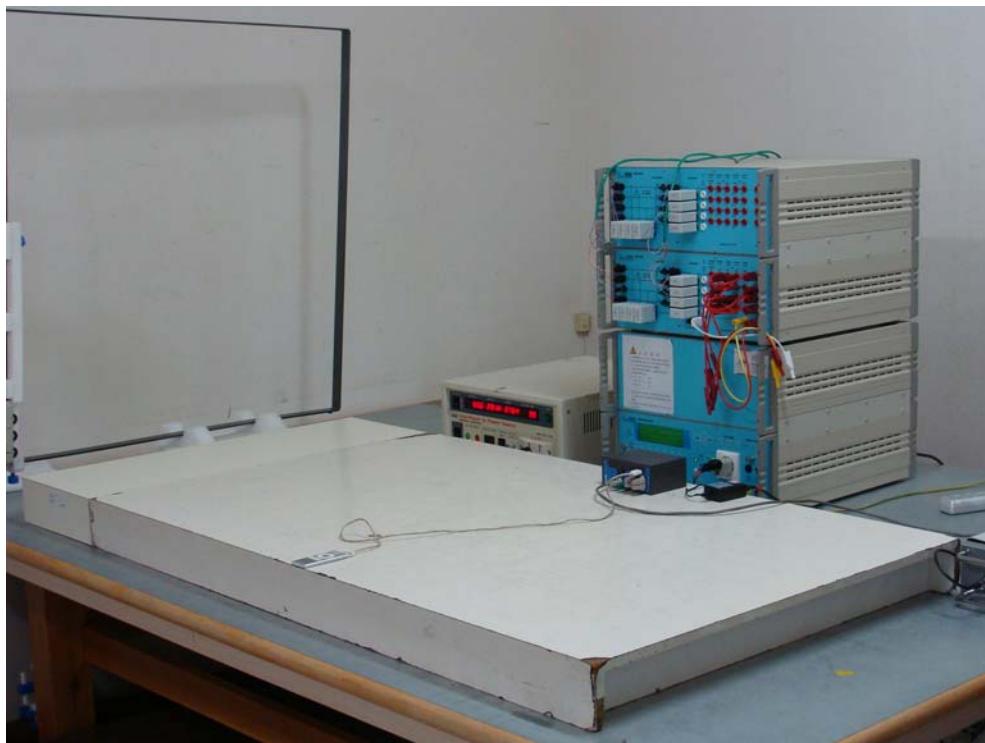

Test Mode : Mode 1: Normal Operation

Description : EFT/B Test Setup-Clamp



11. Surge

11.1. Test Specification

According to Standard : IEC 61000-4-5

11.2. Test Setup

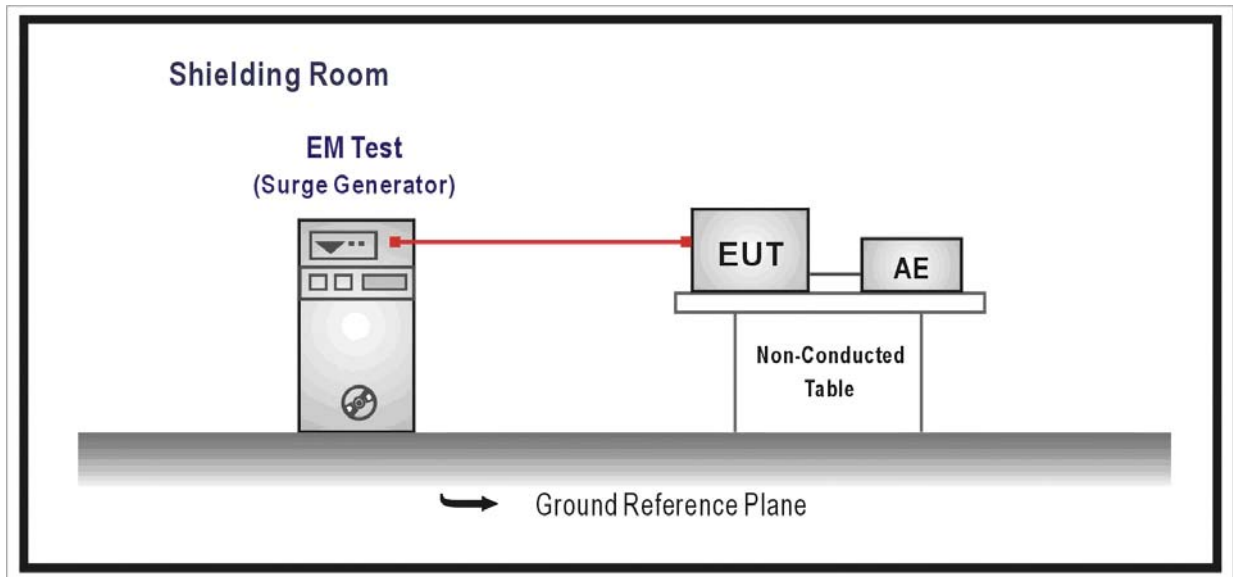

11.3. Limit

Item	Environmental Phenomena	Units	Test Specification	Performance Criteria
Signal Ports and Telecommunication Ports(See 1) and 2))				
	Surges Line to Ground	Tr/Th us kV	1.2/50 (8/20) ± 1	B
Input DC Power Ports				
	Surges Line to Ground	Tr/Th us kV	1.2/50 (8/20) ± 0.5	B
AC Input and AC Output Power Ports				
	Surges Line to Line Line to Ground	Tr/Th us kV kV	1.2/50 (8/20) ± 1 ± 2	B

Notes:

- 1) Applicable only to ports which according to the manufacturer’s may directly to outdoor cables.
- 2) Where normal functioning cannot be achieved because of the impact of the CDN on the EUT, no immunity test shall be required.

11.4. Test Procedure

The EUT and its load are placed on a table that is 0.8 meter above a metal ground plane measured 1m*1m min. and 0.65mm thick min. And projected beyond the EUT by at least 0.1m on all sides. The length of power cord between the coupling device and the EUT shall be 2m or less.

For Input and Output AC Power or DC Input and DC Output Power Ports:

The EUT is connected to the power mains through a coupling device that directly couples the Surge interference signal.

The surge noise shall be applied synchronized to the voltage phase at 0⁰, 90⁰, 180⁰, 270⁰ and the peak value of the a.c. voltage wave. (Positive and negative)

Each of Line-Earth and Line-Line is impressed with a sequence of five surge voltages with interval of 1 min.

11.5. Deviation from Test Standard

No deviation.

11.6. Test Result

Product	RISC-Base Industrial Ready-to-Run Embedded Computer		
Test Item	Surge		
Test Mode	Mode 1: Normal Operation		
Date of Test	2011/05/09	Test Site	No.3 Shielded Room

Inject Line	Polarity	Angle	Voltage kV	Time Interval (Second)	Inject Method	Required Criteria	Complied to Criteria	Result
L-N	±	0	1kV	60	Direct	B	A	PASS
L-N	±	90	1kV	60	Direct	B	A	PASS
L-N	±	180	1kV	60	Direct	B	A	PASS
L-N	±	270	1kV	60	Direct	B	A	PASS

Note:

The testing performed is from lowest level up to the highest level as required by standard, but only highest level is shown on the report.

- Meet criteria A : Operate as intended during and after the test
- Meet criteria B : Operate as intended after the test
- Meet criteria C : Loss/Error of function
- Additional Information
 - EUT stopped operation and could / could not be reset by operator at _____ kV of Line _____.
- No false alarms or other malfunctions were observed during or after the test.

11.7. Test Photograph

Test Mode : Mode 1: Normal Operation

Description : SURGE Test Setup



12. Conducted Susceptibility

12.1. Test Specification

According to Standard : IEC 61000-4-6

12.2. Test Setup

CDN Test Mode

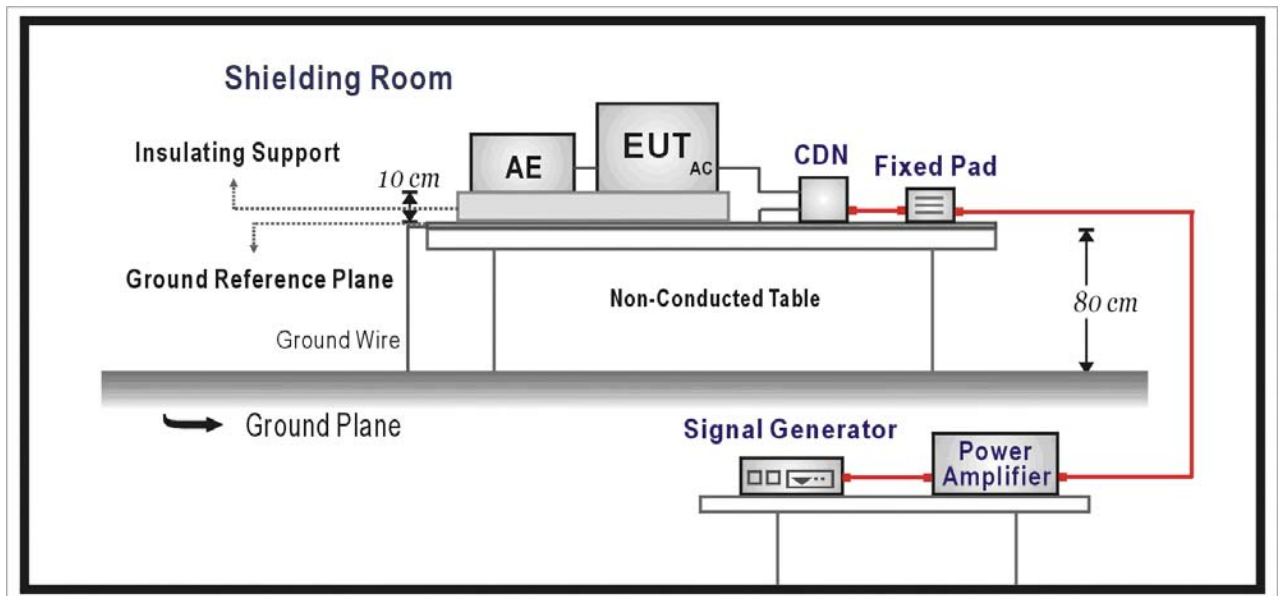

EM Clamp Test Mode

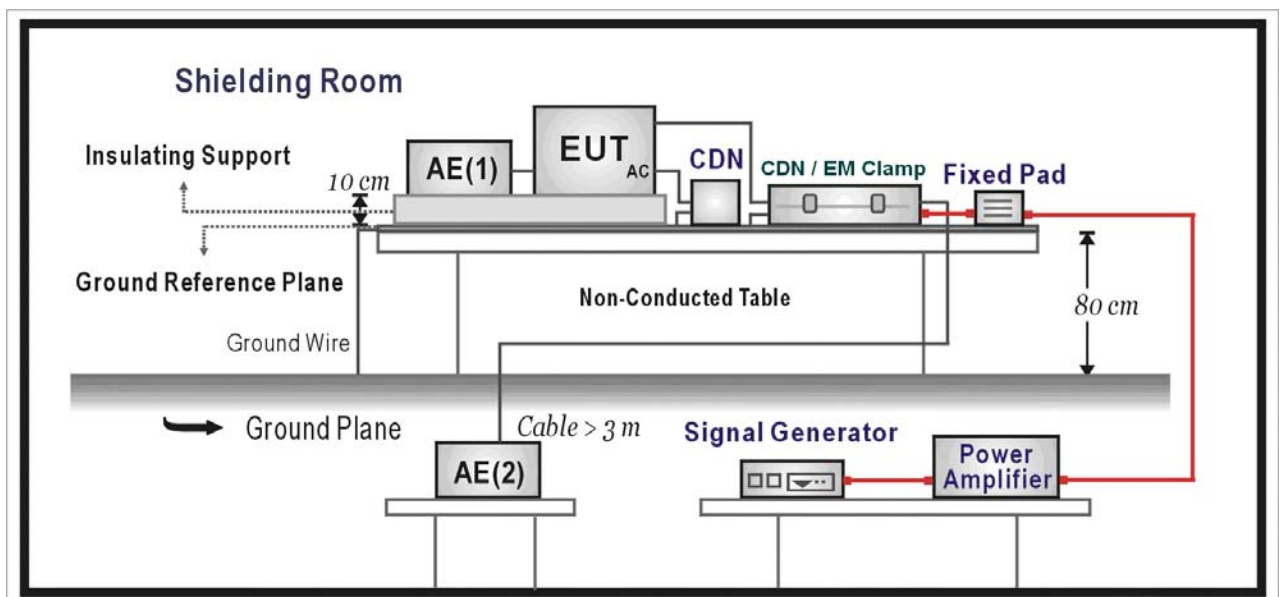

12.3. Limit

Item	Environmental Phenomena	Units	Test Specification	Performance Criteria
Signal Ports and Telecommunication Ports				
	Radio-Frequency Continuous Conducted	MHz V (rms, Un-modulated) % AM (1kHz)	0.15-80 3 80	A
Input DC Power Ports				
	Radio-Frequency Continuous Conducted	MHz V (rms, Un-modulated) % AM (1kHz)	0.15-80 3 80	A
Input AC Power Ports				
	Radio-Frequency Continuous Conducted	MHz V (rms, Un-modulated) % AM (1kHz)	0.15-80 3 80	A

12.4. Test Procedure

The EUT are placed on a table that is 0.8 meter height, and a Ground reference plane on the table, EUT are placed upon table and use a 10cm insulation between the EUT and Ground reference plane.

For Signal Ports and Telecommunication Ports

The disturbance signal is through a coupling and decoupling networks (CDN) or EM-clamp device couples to the signal and Telecommunication lines of the EUT.

For Input DC and AC Power Ports

The EUT is connected to the power mains through a coupling and decoupling networks for power supply lines. And directly couples the disturbances signal into EUT.

Used CDN-M2 for two wires or CDN-M3 for three wires.

All the scanning conditions are as follows:

Condition of Test	Remarks
1. Field Strength	130dBuV(3V) Level 2
2. Radiated Signal	AM 80% Modulated with 1kHz
3. Scanning Frequency	0.15MHz – 80MHz
4. Dwell Time	3 Seconds
5. Frequency step size Δf :	1%
6. The rate of Swept of Frequency	1.5×10^{-3} decades/s

12.5. Deviation from Test Standard

No deviation.

12.6. Test Result

Product	RISC-Base Industrial Ready-to-Run Embedded Computer		
Test Item	Conducted susceptibility		
Test Mode	Mode 1: Normal Operation		
Date of Test	2011/05/06	Test Site	No.6 Shielded Room

Frequency Range (MHz)	Voltage Applied dBuV(V)	Inject Method	Tested Port of EUT	Required Criteria	Performance Criteria Complied To	Result
0.15~80	10V	CDN	AC IN	A	A	PASS
0.15~80	10V	CDN	Communication	A	A	PASS

Note:

The testing performed is from lowest level up to the highest level as required by standard, but only highest level is shown on the report.

- Meet criteria A : Operate as intended during and after the test
- Meet criteria B : Operate as intended after the test
- Meet criteria C : Loss/Error of function
- Additional Information
 - EUT stopped operation and could / could not be reset by operator at _____ dBuV(V) at frequency _____MHz.
 - No false alarms or other malfunctions were observed during or after the test. The acceptance criteria were met, and the EUT passed the test.

12.7. Test Photograph

Test Mode : Mode 1: Normal Operation

Description : Conducted Susceptibility Test Setup



Test Mode : Mode 1: Normal Operation

Description : Conducted Susceptibility Test Setup-CDN



13. Power Frequency Magnetic Field

13.1. Test Specification

According to Standard : IEC 61000-4-8

13.2. Test Setup

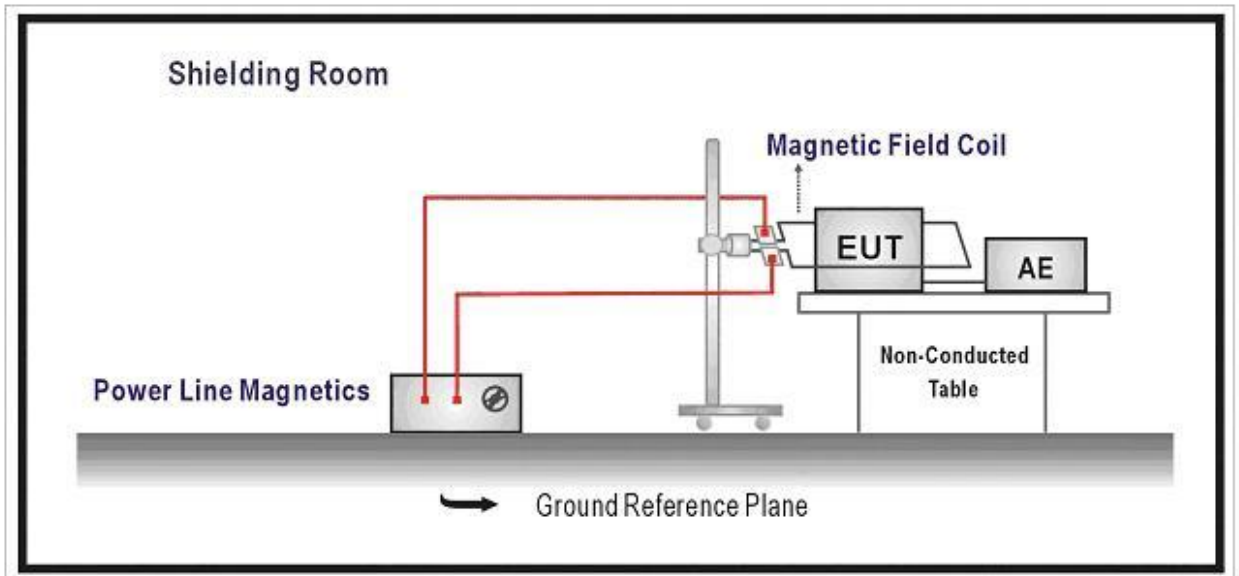

13.3. Limit

Item	Environmental Phenomena	Units	Test Specification	Performance Criteria
Enclosure Port				
	Power-Frequency Magnetic Field	Hz A/m (r.m.s.)	50 1	A

13.4. Test Procedure

The EUT and its load are placed on a table which is 0.8 meter above a metal ground plane measured at least 1m*1m min. The test magnetic field shall be placed at central of the induction coil.

The test magnetic Field shall be applied 10 minutes by the immersion method to the EUT. And the induction coil shall be rotated by 90° in order to expose the EUT to the test field with different orientation (X, Y, Z Orientations).

13.5. Deviation from Test Standard

No deviation.

13.6. Test Result

Product	RISC-Base Industrial Ready-to-Run Embedded Computer		
Test Item	Power frequency magnetic field		
Test Mode	Mode 1: Normal Operation		
Date of Test	2011/05/06	Test Site	No.3 Shielded Room

Polarization	Frequency (Hz)	Magnetic Strength (A/m)	Required Performance Criteria	Performance Criteria Complied To	Test Result
X Orientation	50	1	A	A	PASS
Y Orientation	50	1	A	A	PASS
Z Orientation	50	1	A	A	PASS

- Meet criteria A: Operate as intended during and after the test
- Meet criteria B: Operate as intended after the test
- Meet criteria C: Loss/Error of function
- Additional Information
 - EUT stopped operation and could / could not be reset by operator at _____ kV of Line _____.
- No false alarms or other malfunctions were observed during or after the test. The acceptance criteria were met, and the EUT passed the test.

13.7. Test Photograph

Test Mode : Mode 1: Normal Operation

Description : Power Frequency Magnetic Field Test Setup



14. Voltage Dips and Interruption

14.1. Test Specification

According to Standard : IEC 61000-4-11

14.2. Test Setup

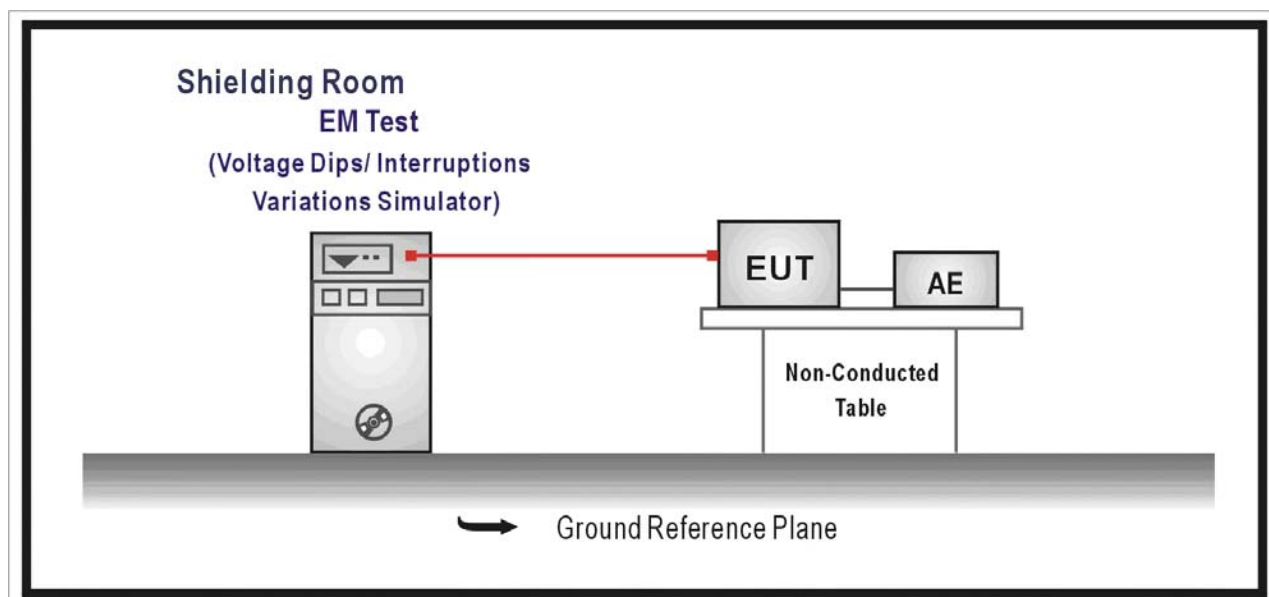

14.3. Limit

Item	Environmental Phenomena	Units	Test Specification	Performance Criteria
Input AC Power Ports				
	Voltage Dips	% Reduction	30	C
		Period	25	
	Voltage Dips	% Reduction	>95	B
		Period	0.5	
	Voltage Interruptions	% Reduction	> 95	C
		Period	250	

14.4. Test Procedure

The EUT and its load are placed on a table which is 0.8 meter above a metal ground plane measured 1m*1m min. And 0.65mm thick min. And projected beyond the EUT by at least 0.1m on all sides. The power cord shall be used the shortest power cord as specified by the manufacturer.

For Voltage Dips/ Interruptions test:

The selection of test voltage is based on the rated power range. If the operation range is large than 20% of lower power range, both end of specified voltage shall be tested.

Otherwise, the typical voltage specification is selected as test voltage.

The EUT is connected to the power mains through a coupling device that directly couples to the Voltage Dips and Interruption Generator.

The EUT shall be tested for 30% voltage dip of supplied voltage and duration 25 Periods, for 95% voltage dip of supplied voltage and duration 0.5 Periods with a sequence of three voltage dips with intervals of 10 seconds, and for 95% voltage interruption of supplied voltage and duration 250 Periods with a sequence of three voltage interruptions with intervals of 10 seconds.

Voltage phase shifting are shall occur at 0° , 45° , 90° , 135° , 180° , 225° , 270° , 315° of the voltage.

14.5. Deviation from Test Standard

No deviation.

14.6. Test Result

Product	RISC-Base Industrial Ready-to-Run Embedded Computer		
Test Item	Voltage dips and interruption		
Test Mode	Mode 1: Normal Operation		
Date of Test	2011/05/09	Test Site	No.3 Shielded Room

Voltage Dips and Interruption Reduction(%)	Angle	Test Duration (Periods)	Required Performance Criteria	Performance Criteria Complied To	Test Result
30	0	25	C	A	PASS
30	45	25	C	A	PASS
30	90	25	C	A	PASS
30	135	25	C	A	PASS
30	180	25	C	A	PASS
30	225	25	C	A	PASS
30	270	25	C	A	PASS
30	315	25	C	A	PASS
>95	0	0.5	B	A	PASS
>95	45	0.5	B	A	PASS
>95	90	0.5	B	A	PASS
>95	135	0.5	B	A	PASS
>95	180	0.5	B	A	PASS
>95	225	0.5	B	A	PASS
>95	270	0.5	B	A	PASS
>95	315	0.5	B	A	PASS
>95	0	250	C	B	PASS
>95	45	250	C	B	PASS
>95	90	250	C	B	PASS
>95	135	250	C	B	PASS
>95	180	250	C	B	PASS
>95	225	250	C	B	PASS
>95	270	250	C	B	PASS
>95	315	250	C	B	PASS

- Meet criteria A: Operate as intended during and after the test
- Meet criteria B: Operate as intended after the test
- Meet criteria C: Loss/Error of function
- Additional Information
 - The nominal voltage of EUT is 230V.
 - EUT stopped operation and could / could not be reset by operator at _____ kV of Line _____.

No false alarms or other malfunctions were observed during or after the test. The acceptance criteria were met, and the EUT passed the test.

14.7. Test Photograph

Test Mode : Mode 1: Normal Operation

Description : Voltage Dips Test Setup

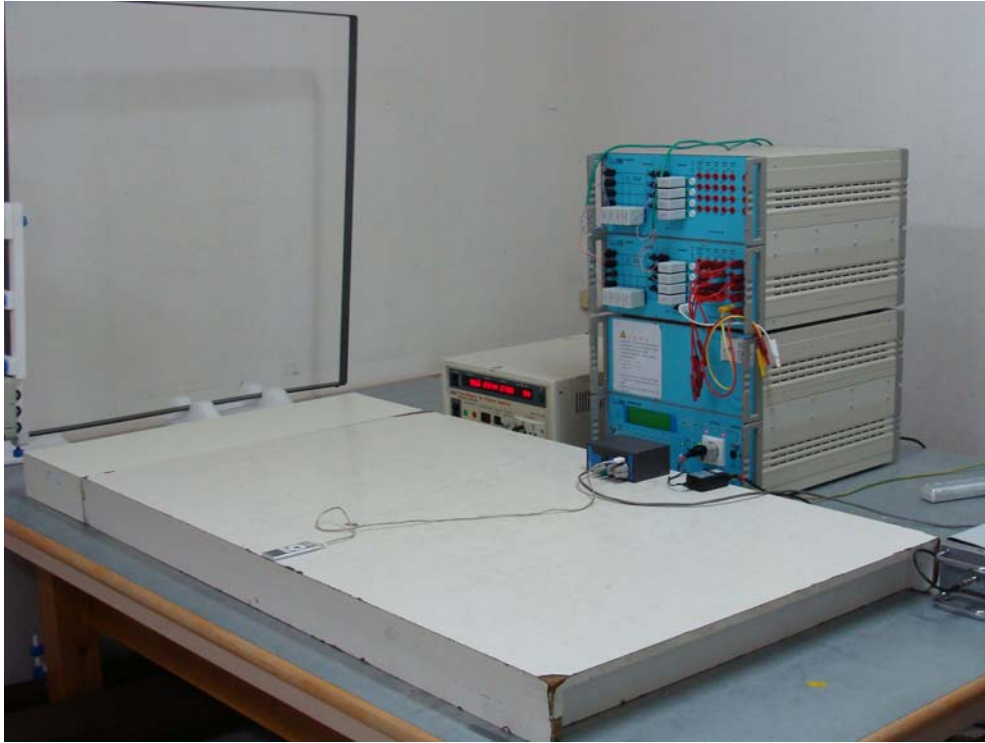

15. Attachment

➤ EUT Photograph

(1) EUT Photo



(2) EUT Photo



(3) EUT Photo



(4) EUT Photo



(5) EUT Photo



(6) EUT Photo



(7) EUT Photo



(8) EUT Photo



(9) EUT Photo

