



CERTIFICATE

Issued Date: Apr. 17, 2006
Report No.: 063L086-IT-CE-P07V03

This is to certify that the following designated product

Product : Ether Device Switch
Trade name : Moxa
Model Number : EDS-518A-X1-X2-X3-X4, EDS-516A-X1-X2-X3-X4
X1 = M or S or MM or MS or SS or blank (stands for Fiber mode)
X2 = SC or ST or blank (stands for Fiber Category)
X3 = 40 or 80 or blank (stands for Fiber transmissible distance)
X4 = 0-9, A-Z or blank (for marketing purpose)
Company Name : Moxa Networking Co., Ltd

This product, which has been issued the test report listed as above in QuieTek Laboratory, is based on a single evaluation of one sample and confirmed to comply with the requirements of the following EMC standard.

EN 55022: 1998+A1: 2000+A2: 2003	EN 55024: 1998+A1: 2001+A2: 2003
EN 61000-3-2: 2000	IEC 61000-4-2 Edition 1.2: 2001-04 (Level 2)
EN 61000-3-3: 1995 + A1:2001	IEC 61000-4-3: 2002+A1: 2002(Level 3)
	IEC 61000-4-4: 2004(Level 2)
	IEC 61000-4-5 Edition 1.1: 2001-04(Level 3)
	IEC 61000-4-6 Edition 2.1: 2004-11(Level 3)
	IEC 61000-4-8 Edition 1.1: 2001-03
	IEC 61000-4-11 Second Edition: 2004-03

TEST LABORATORY

George Chen / President



Test Report

Product Name : Ether Device Switch

Model No. : EDS-518A-X1-X2-X3-X4, EDS-516A-X1-X2-X3-X4

X1 = M or S or MM or MS or SS or blank (stands for Fiber mode)

X2 = SC or ST or blank (stands for Fiber Category)

X3 = 40 or 80 or blank (stands for Fiber transmissible distance)

X4 = 0-9, A-Z or blank (for marketing purpose)

Applicant : Moxa Networking Co., Ltd

Address : F1.8, No. 6, Alley 6, Lane 235, Pao-Chiao Rd. Shing
Tien City, Taiwan, R.O.C.

Date of Receipt : 2006/03/14

Issued Date : 2006/04/17

Report No. : 063L086-IT-CE-P07V03

The test results relate only to the samples tested.

The test results shown in the test report are traceable to the national/international standard through the calibration of the equipment and evaluated measurement uncertainty herein.

This report must not be used to claim product endorsement by CNLA, NVLAP or any agency of the Government.

The test report shall not be reproduced except in full without the written approval of QuieTek Corporation.



Declaration of Conformity

The following product is herewith confirmed to comply with the requirements set out in the Council Directive on the Approximation of the laws of the Member States relating to Electromagnetic Compatibility Directive (89/336/EEC). The listed standards as below were applied:

19

The following Equipment:

Product : Ether Device Switch
 Model Number : EDS-518A-X1-X2-X3-X4,EDS-516A-X1-X2-X3-X4
 X1 = M or S or MM or MS or SS or blank (stands for Fiber mode)
 X2 = SC or ST or blank (stands for Fiber Category)
 X3 = 40 or 80 or blank (stands for Fiber transmissible distance)
 X4 = 0-9, A-Z or blank (for marketing purpose)
 Trade Name : Moxa

This product is herewith confirmed to comply with the requirements set out in the Council Directive on the Approximation of the laws of the Member States relating to Electromagnetic Compatibility Directive (89/336/EEC). For the evaluation regarding EMC, the following standards were applied:

RFI Emission:

EN 55022:1998+A1:2000+A2:2003 Class A : Product family standard
 EN 61000-3-2:2000 : Limits for harmonic current emission
 EN 61000-3-3:1995+A1:2001 : Limitation of voltage fluctuation and flicker in low-voltage supply system

Immunity:

EN 55024:1998+A1:2001+A2:2003 : Product family standard

The following importer/manufacturer is responsible for this declaration:

Company Name : _____
 Company Address : _____
 Telephone : _____ Facsimile : _____

Person is responsible for marking this declaration:

Name (Full Name)

Position/ Title

Date

Legal Signature

CE Statement of Conformity

This certifies that the following designated product:

Product : Ether Device Switch
Model Number : EDS-518A-X1-X2-X3-X4, EDS-516A-X1-X2-X3-X4
X1 = M or S or MM or MS or SS or blank (stands for Fiber mode)
X2 = SC or ST or blank (stands for Fiber Category)
X3 = 40 or 80 or blank (stands for Fiber transmissible distance)
X4 = 0-9, A-Z or blank (for marketing purpose)
Trade Name : Moxa
Company Name : Moxa Networking Co., Ltd

This product is herewith confirmed to comply with the requirements set out in the Council Directive on the Approximation of the laws of the Member States relating to Electromagnetic Compatibility Directive (89/336/EEC). For the evaluation regarding EMC, the following standards were applied:

RFI Emission:

EN 55022:1998+A1:2000+A2:2003 Class A : Product family standard
EN 61000-3-2:2000 : Limits for harmonic current emission
EN 61000-3-3:1995+A1:2001 : Limitation of voltage fluctuation and flicker in low-voltage supply system

Immunity:

EN 55024:1998+A1:2001+A2:2003 : Product family standard



0914

TEST LABORATORY

George Chen

George Chen / President

The verification is based on a single evaluation of one sample of above-mentioned products. It does not imply an assessment of the whole production and does not permit the use of the test lab. Logo.

Test Report Certification

Issued Date : 2006/04/17

Report No. : 063L086-IT-CE-P07V03



Product Name : Ether Device Switch
Applicant : Moxa Networking Co., Ltd
Address : F1.8, No. 6, Alley 6, Lane 235, Pao-Chiao Rd. Shing Tien City,
Taiwan, R.O.C.
Manufacturer : Moxa Networking Co., Ltd
Model No. : EDS-518A-X1-X2-X3-X4, EDS-516A-X1-X2-X3-X4
X1 = M or S or MM or MS or SS or blank (stands for Fiber mode)
X2 = SC or ST or blank (stands for Fiber Category)
X3 = 40 or 80 or blank (stands for Fiber transmissible distance)
X4 = 0-9, A-Z or blank (for marketing purpose)
Rated Voltage : AC 230 V / 50 Hz
EUT Voltage : DC 12V, 1.25A
Trade Name : Moxa
Applicable Standard : EN 55022: 1998+A1: 2000+A2: 2003 Class A
EN 55024: 1998+A1: 2001+A2: 2003
EN 61000-3-2:2000 EN 61000-3-3:1995+A1:2001
Test Result : Complied
Performed Location : Linkou EMC laboratory
No.5-22, Ruei-Shu Valley, Ruei-Ping Tsuen Lin Kuo Shiang, Taipei,
244 Taiwan, R.O.C.
TEL:+866-2-8601-3788 / FAX:+866-2-8601-3789

Documented By : Leven Huang
(Engineering Adm. Assistant / Leven Huang)

Reviewed By : Tommy Chen
(Assistant Engineer / Tommy Chen)

Approved By : George Chen
(Vice President / George Chen)

Laboratory Information

We , **Quietek Corporation**, are an independent EMC and safety consultancy that was established the whole facility in our laboratories. The test facility has been accredited by the following accreditation Bodies in compliance with ISO 17025, EN 45001 and Guide 25:

Taiwan R.O.C.	: BSMI, DGT, CNLA
Germany	: TÜV Rheinland
Norway	: Nemko, DNV
USA	: FCC, NVLAP
Japan	: VCCI

The related certificate for our laboratories about the test site and management system can be downloaded from Quietek Corporation's Web Site : <http://tw.quietek.com/modules/myalbum/>

The address and introduction of Quietek Corporation's laboratories can be founded in our Web site : <http://www.quietek.com/>

If you have any comments, Please don't hesitate to contact us. Our contact information is as below:

HsinChu Testing Laboratory :

No.75-2, 3rd Lin, Wangye Keng, Yonghxing Tsuen, Qionglin Shiang, Hsinchu County 307, Taiwan, R.O.C.

TEL:+886-3-592-8858 / FAX:+886-3-592-8859

E-Mail : service@quietek.com



LinKou Testing Laboratory :

No. 5-22, Ruei-Shu Valley, Ruei-Ping Tsuen, Lin-Kou Shiang, Taipei, Taiwan, R.O.C.

TEL : 886-2-8601-3788 / FAX : 886-2-8601-3789

E-Mail : service@quietek.com



TABLE OF CONTENTS

Description	Page
1. General Information	6
1.1. EUT Description.....	6
1.2. Mode of Operation	7
1.3. Tested System Details	8
1.4. Configuration of Tested System	9
1.5. EUT Exercise Software.....	10
2. Technical Test	11
2.1. Summary of Test Result.....	11
2.2. List of Test Equipment	12
2.3. Measurement Uncertainty.....	15
2.4. Test Environment.....	17
3. Conducted Emissions (Telecommunication Ports).....	19
3.1. Test Specification	19
3.2. Test Setup.....	19
3.3. Limit	19
3.4. Test Procedure	20
3.5. Deviation from Test Standard.....	20
3.6. Test Result	21
3.7. Test Photograph	27
4. Radiated Emission.....	28
4.1. Test Specification	28
4.2. Test Setup.....	28
4.3. Limit	28
4.4. Test Procedure	29
4.5. Deviation from Test Standard.....	29
4.6. Test Result	30
4.7. Test Photograph	32
5. Electrostatic Discharge	33
5.1. Test Specification	33
5.2. Test Setup.....	33
5.3. Limit	33
5.4. Test Procedure	34
5.5. Deviation from Test Standard.....	34
5.6. Test Result.....	35
5.7. Test Photograph	36
6. Radiated Susceptibility	37

6.1.	Test Specification	37
6.2.	Test Setup.....	37
6.3.	Limit.....	37
6.4.	Test Procedure	38
6.5.	Deviation from Test Standard	38
6.6.	Test Result.....	39
6.7.	Test Photograph	40
7.	Electrical Fast Transient/Burst	41
7.1.	Test Specification	41
7.2.	Test Setup.....	41
7.3.	Limit.....	41
7.4.	Test Procedure	42
7.5.	Deviation from Test Standard	42
7.6.	Test Result.....	43
7.7.	Test Photograph	44
8.	Surge	45
8.1.	Test Specification	45
8.2.	Test Setup.....	45
8.3.	Limit.....	45
8.4.	Test Procedure	46
8.5.	Deviation from Test Standard	46
8.6.	Test Result.....	47
8.7.	Test Photograph	48
9.	Conducted Susceptibility.....	49
9.1.	Test Specification	49
9.2.	Test Setup.....	49
9.3.	Limit.....	50
9.4.	Test Procedure	50
9.5.	Deviation from Test Standard	50
9.6.	Test Result.....	51
9.7.	Test Photograph	52
10.	Attachment	53
	EUT Photograph.....	53

1. General Information

1.1. EUT Description

Product Name	Ether Device Switch
Trade Name	Moxa
Model No.	EDS-518A-X1-X2-X3-X4, EDS-516A-X1-X2-X3-X4 X1 = M or S or MM or MS or SS or blank (stands for Fiber mode) X2 = SC or ST or blank (stands for Fiber Category) X3 = 40 or 80 or blank (stands for Fiber transmissible distance) X4 = 0-9, A-Z or blank (for marketing purpose)

Note: The different of each model is shown as below:

Model Number	Description
EDS-518A-X1-X2-X3-X4	X1 = M or S or MM or MS or SS or blank (stands for Fiber mode) X2 = SC or ST or blank (stands for Fiber Category)
EDS-516A-X1-X2-X3-X4	X3 = 40 or 80 or blank (stands for Fiber transmissible distance) X4 = 0-9, A-Z or blank (for marketing purpose)

1.2. Mode of Operation

QuieTek has verified the construction and function in typical operation. All the test modes were carried out with the EUT in normal operation, which was shown in this test report and defined as:

Pre-Test Mode	
Mode 1:Normal Operation(fiber optics)	
Mode 2:Normal Operation(LAN)	
Final Test Mode	
Emission	Mode 1:Normal Operation(fiber optics)
Immunity	Mode 1:Normal Operation(fiber optics)

1.3. Tested System Details

The types for all equipments, plus descriptions of all cables used in the tested system (including inserted cards) are:

Product		Manufacturer	Model No.	Serial No.	Power Cord
1	PC	COMPAQ	Evo D310	SG30801023	Non-Shielded, 1.8m
2	PC	COMPAQ	Evo D310	SG30801054	Non-Shielded, 1.8m
3	PC	COMPAQ	Evo D310	SG30801008	Non-Shielded, 1.8m

1.4. Configuration of Tested System

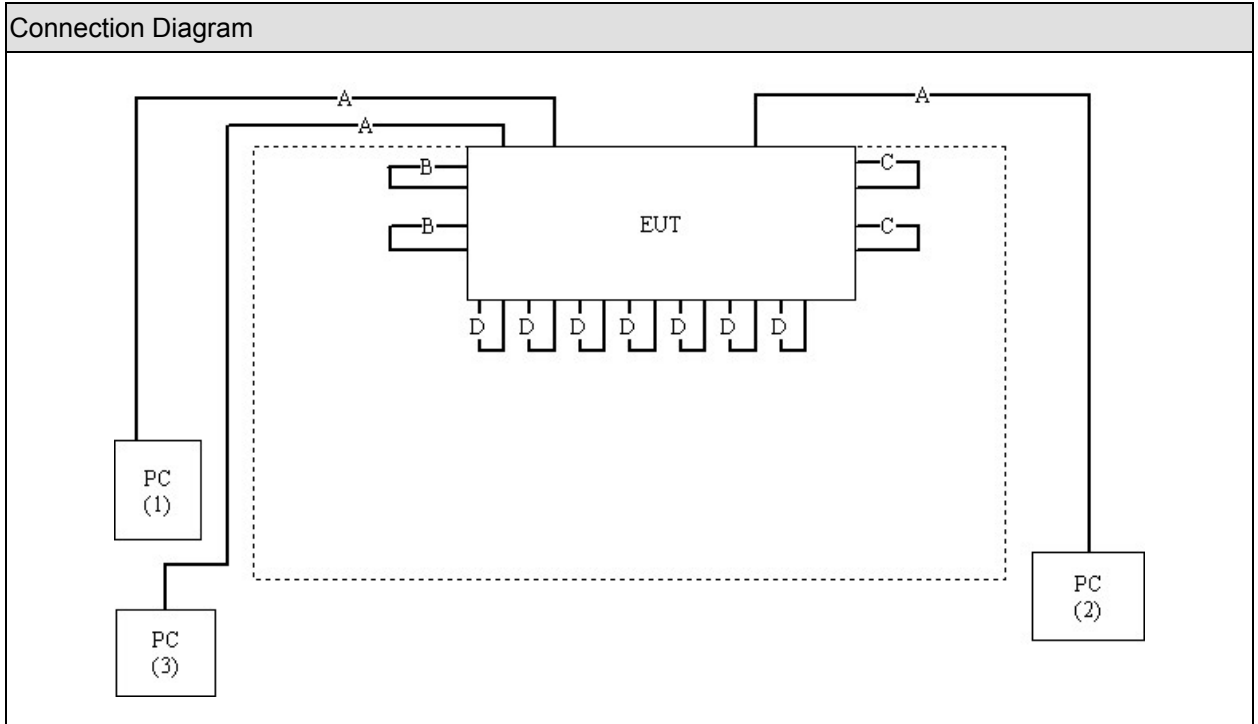

Signal Cable Type		Signal cable Description
A	LAN Cable	Non-Shielded, 7m, three PCS.
B	Fiber Cable	Non-Shielded, 1.1m, two PCS.
C	Fiber Cable	Non-Shielded, 1.2m, two PCS.
D	LAN Cable	Non-Shielded, 0.3m, seven PCS.

1.5. EUT Exercise Software

1	Setup the EUT and simulators as shown on 1.4.
2	Turn on the power of all equipment.
3	Boot the PC from Hard Disk.
4	Data will be communicated between computer and EUT.
5	The personal computer monitors' will show the transmitting and receiving characteristics when the communication is success.
6	Repeat the above procedure (4) to (5).

2. Technical Test

2.1. Summary of Test Result

- No deviations from the test standards
 Deviations from the test standards as below description:

Emission			
Performed Item	Normative References	Test Performed	Deviation
Conducted Emission	EN 55022:1998+A1:2000+A2:2003 Class A	No	No
Conducted Emissions (Telecommunication Ports)	EN 55022:1998+A1:2000+A2:2003 Class A	No	No
Radiated Emission	EN 55022:1998+A1:2000+A2:2003 Class A	Yes	No
Power Harmonics	EN 61000-3-2:2000	No	No
Voltage Fluctuation and Flicker	EN 61000-3-3:1995+A1:2001	No	No

Immunity			
Performed Item	Normative References	Test Performed	Deviation
Electrostatic Discharge	IEC 61000-4-2 Edition 1.2: 2001-04	Yes	No
Radiated susceptibility	IEC 61000-4-3:2002+A1:2002	Yes	No
Electrical fast transient/burst	IEC 61000-4-4:2004	Yes	No
Surge	IEC 61000-4-5 Edition 1.1: 2001-04	Yes	No
Conducted susceptibility	IEC 61000-4-6 Edition 2.1: 2004-11	Yes	No
Power frequency magnetic field	IEC 61000-4-8 Edition 1.1: 2001-03	No	No
Voltage dips and interruption	IEC 61000-4-11 2nd Edition: 2004-03	No	No

2.2. List of Test Equipment

Conducted Emissions (Telecommunication Ports) / SR1

Instrument	Manufacturer	Type No.	Serial No	Cal. Date
Schaffner NSG 2070 RF-Generator				
Capacitive Voltage Probe	Schaffner	CVP2200A	18331	2005/11/11
EMI Test Receiver	R&S	ESCS 30	836858/022	2006/02/18
LISN	R&S	ESH3-Z5	836679/020	2006/02/14
LISN	R&S	ENV4200	833209/007	2005/07/27
Impedance Stabilization Network	Schaffner	ISN T400	19099	2005/07/14
Pulse Limiter	R&S	ESH3-Z2	357.88.10.52	2005/09/07
RF Current Probe	FCC	F-65 10KHz~1GHz	198	2005/11/11

Radiated Emission / Site4

Instrument	Manufacturer	Type No.	Serial No	Cal. Date
Bilog Antenna	Schaffner Chase	CBL6112B	2793	2005/09/15
Broadband Horn Antenna	Schwarzbeck	BBHA9170	208	2005/07/25
EMI Test Receiver	R&S	ESCS 30	100366	2005/10/01
Horn Antenna	Schwarzbeck	BBHA9120D	305	2005/08/10
Pre-Amplifier	QTK	N/A	N/A	2006/01/03
Spectrum Analyzer	Advantest	R3162	100803468	2005/10/24

Power Harmonics /

Instrument	Manufacturer	Type No.	Serial No	Cal. Date
<Instrument>	<InsManufacturer>	<InsTypeNo>	<InsSerialNo>	<InsCalDate>

Voltage Fluctuation and Flicker /

Instrument	Manufacturer	Type No.	Serial No	Cal. Date
<Instrument>	<InsManufacturer>	<InsTypeNo>	<InsSerialNo>	<InsCalDate>

Electrostatic Discharge / SR3

Instrument	Manufacturer	Type No.	Serial No	Cal. Date
ESD simulator system	Schaffner	NSG 438	167	2006/03/24
Horizontal Coupling Plane(HCP)	Quietek	HCP AL50	N/A	N/A
Vertical Coupling Plane(VCP)	Quietek	VCP AL50	N/A	N/A

Radiated susceptibility / CB5

Instrument	Manufacturer	Type No.	Serial No	Cal. Date
AF-BOX	R&S	AF-BOX ACCUST	100007	N/A
Audio Analyzer	R&S	UPL 16	100137	2006/03/16
Bilog Antenna	Schaffner Chase	CBL6112B	2450	2006/01/03
Broad-Band Antenna	Schwarzbeck	VULB 9166	1085	2005/08/01
CMU200 UNIV.RADIOCOMM	R&S	CMU200	104846	2006/03/16
Directional Coupler	A&R	DC 6180	22735	2005/08/03
Dual Microphone Supply	B&K	5935	2426784	2005/08/03
Mouth Simulator	B&K	4227	2439692	2005/08/03
Power Amplifier	A&R	30S1G3	309453	N/A

Power Amplifier	A&R	100W10000M7	A285000010	N/A
Power Meter	R&S	NRVD(P.M)	100219	2005/01/17
Pre-Amplifier	A&R	150A220	23067	N/A
Probe Microphone	B&K	4182	2278070	2005/08/03
Signal Generator	R&S	SMY02(9K-2080)	825454/028	2005/10/03

Electrical fast transient/burst / SR2

Instrument	Manufacturer	Type No.	Serial No	Cal. Date
Schaffner NSG 2050 System Mainframe				

Surge / SR2

Instrument	Manufacturer	Type No.	Serial No	Cal. Date
Schaffner NSG 2050 System Mainframe				

Conducted susceptibility / SR6

Instrument	Manufacturer	Type No.	Serial No	Cal. Date
Schaffner NSG 2070 RF-Generator				
N/A	N/A	N/A	N/A	N/A

Power frequency magnetic field /

Instrument	Manufacturer	Type No.	Serial No	Cal. Date
<Instrument>	<InsManufacturer>	<InsTypeNo>	<InsSerialNo>	<InsCalDate>

Voltage dips and interruption /

Instrument	Manufacturer	Type No.	Serial No	Cal. Date
Schaffner NSG 2050 System Mainframe				

Schaffner NSG 2050 System Mainframe				
Instrument	Manufacturer	Type No.	Serial No	Cal. Date
Burst 4.8KV/16A Generator with CDN	Schaffner	PNW2225	200123-098SC	2005/12/28
Damped osc. Wave 100kHz and 1MHz	Schaffner	PNW2056	200124-058SC	2005/12/28
Double AC Source Variator	Schaffner	NSG 642A	30910014938	2005/12/28
Hybrid surge pulse 1.2/50uS	Schaffner	PNW 2050	20532-514LU	2006/01/03
PQT Generator	Schaffner	PNW2003	200138-007SC	2006/01/02
Pulse COUPLING NETWORK	Schaffner	CDN131	200124-007SC	2005/12/28

Schaffner NSG 2070 RF-Generator				
Instrument	Manufacturer	Type No.	Serial No	Cal. Date
CDN	Schaffner	CAL U100A	20405	2006/03/27
CDN	Schaffner	TRA U150	20454	2006/03/27
CDN M016S	Schaffner	CAL U100A	20410	2006/03/27
CDN M016S	Schaffner	TRA U150	21167	2006/03/27
CDN T002	Schaffner	CAL U100	20491	2006/03/27
CDN T002	Schaffner	TRA U150	21169	2006/03/27
CDN T400	Schaffner	CAL U100	17735	2006/03/27

CDN T400	Schaffner	TRA U150	21166	2006/03/27
Coupling Decoupling Network	Schaffner	CDN M016S	20822	2006/03/27
Coupling Decoupling Network	Schaffner	CDN M016S	20823	2006/03/27
Coupling Decoupling Network	Schaffner	CDN T002	19018	2006/03/27
Coupling Decoupling Network	Schaffner	CDN T400	21226	2006/03/27
EM-CLAMP	Schaffner	KEMZ 801	21024	2005/04/21

2.3. Measurement Uncertainty

Conducted Emission

The measurement uncertainty is evaluated as ± 2.26 dB.

Conducted Emissions (Telecommunication Ports)

The measurement uncertainty is evaluated as ± 2.26 dB.

Radiated Emission

The measurement uncertainty is evaluated as ± 3.19 dB.

Electrostatic Discharge

As what is concluded in the document from Note2 of clause 5.4.6.2 of ISO/IEC 17025: 1999[2], the requirements for measurement uncertainty in ESD testing are deemed to have been satisfied, and the testing is reported in accordance with the relevant ESD standards. The immunity test signal from the ESD system meet the required specifications in IEC 61000-4-2 through the calibration report with the calibrated uncertainty for the waveform of voltage and timing as being 1.63 % and 2.76%.

Radiated susceptibility

As what is concluded in the document from Note2 of clause 5.4.6.2 of ISO/IEC 17025: 1999[2], the requirements for measurement uncertainty in RS testing are deemed to have been satisfied, and the testing is reported in accordance with the relevant RS standards. The immunity test signal from the RS system meet the required specifications in IEC 61000-4-3 through the calibration for the uniform field strength and monitoring for the test level with the uncertainty evaluation report for the electrical field strength as being 2.72 dB.

Electrical fast transient/burst

As what is concluded in the document from Note2 of clause 5.4.6.2 of ISO/IEC 17025: 1999[2], the requirements for measurement uncertainty in EFT/Burst testing are deemed to have been satisfied, and the testing is reported in accordance with the relevant EFT/Burst standards. The immunity test signal from the EFT/Burst system meet the required specifications in IEC 61000-4-4 through the calibration report with the calibrated uncertainty for the waveform of voltage, frequency and timing as being 1.63 %, 2.8 10-10 and 2.76%.

Surge

As what is concluded in the document from Note2 of clause 5.4.6.2 of ISO/IEC 17025: 1999[2], the requirements for measurement uncertainty in Surge testing are deemed to have been satisfied, and the testing is reported in accordance with the relevant Surge standards. The immunity test signal from the Surge system meet the required specifications in IEC 61000-4-5 through the calibration report with the calibrated uncertainty for the waveform of voltage and timing as being 1.63 % and 2.76%.

Conducted susceptibility

As what is concluded in the document from Note2 of clause 5.4.6.2 of ISO/IEC 17025: 1999[2], the requirements for measurement uncertainty in CS testing are deemed to have been satisfied, and the testing is reported in accordance with the relevant CS standards. The immunity test signal from the CS system meet the required specifications in IEC 61000-4-6 through the calibration for unmodulated signal and monitoring for the test level with the uncertainty evaluation report for the injected modulated signal level through CDN and EM Clamp/Direct Injection as being 3.72 dB and 2.78 dB.

Power frequency magnetic field

As what is concluded in the document from Note2 of clause 5.4.6.2 of ISO/IEC 17025: 1999[2], the requirements for measurement uncertainty in PFM testing are deemed to have been satisfied, and the testing is reported in accordance with the relevant PFM standards. The immunity test signal from the PFM system meet the required specifications in IEC 61000-4-8 through the calibration report with the calibrated uncertainty for the Gauss Meter to verify the output level of magnetic field strength as being 2 %.

Voltage dips and interruption

As what is concluded in the document from Note2 of clause 5.4.6.2 of ISO/IEC 17025: 1999[2], the requirements for measurement uncertainty in DIP testing are deemed to have been satisfied, and the testing is reported in accordance with the relevant DIP standards. The immunity test signal from the DIP system meet the required specifications in IEC 61000-4-11 through the calibration report with the calibrated uncertainty for the waveform of voltage and timing as being 1.63 % and 2.76%.

2.4. Test Environment

Performed Item	Items	Required	Actual
Conducted Emission	Temperature (°C)	25-75	
	Humidity (%RH)	15-35	
	Barometric pressure (mbar)	860-1060	
Conducted Emissions (Telecommunication Ports)	Temperature (°C)	15-35	25
	Humidity (%RH)	25-75	50
	Barometric pressure (mbar)	860-1060	950-1000
Radiated Emission	Temperature (°C)	15-35	25
	Humidity (%RH)	25-75	50
	Barometric pressure (mbar)	860-1060	950-1000
Electrostatic Discharge	Temperature (°C)	15-35	20.2
	Humidity (%RH)	30-60	55
	Barometric pressure (mbar)	860-1060	950-1000
Radiated susceptibility	Temperature (°C)	15-35	22
	Humidity (%RH)	25-75	45
	Barometric pressure (mbar)	860-1060	950-1000
Electrical fast transient/burst	Temperature (°C)	15-35	24.6
	Humidity (%RH)	25-75	52
	Barometric pressure (mbar)	860-1060	950-1000
Surge	Temperature (°C)	15-35	24.7
	Humidity (%RH)	10-75	52
	Barometric pressure (mbar)	860-1060	950-1000
Conducted susceptibility	Temperature (°C)	15-35	23.2
	Humidity (%RH)	25-75	45
	Barometric pressure (mbar)	860-1060	950-1000
	Temperature (°C)	15-35	

Power frequency magnetic field	Humidity (%RH)	25-75	
	Barometric pressure (mbar)	860-1060	
Voltage dips and interruption	Temperature (°C)	15-35	
	Humidity (%RH)	25-75	
	Barometric pressure (mbar)	860-1060	

3. Conducted Emissions (Telecommunication Ports)

3.1. Test Specification

According to EMC Standard : EN 55022

3.2. Test Setup

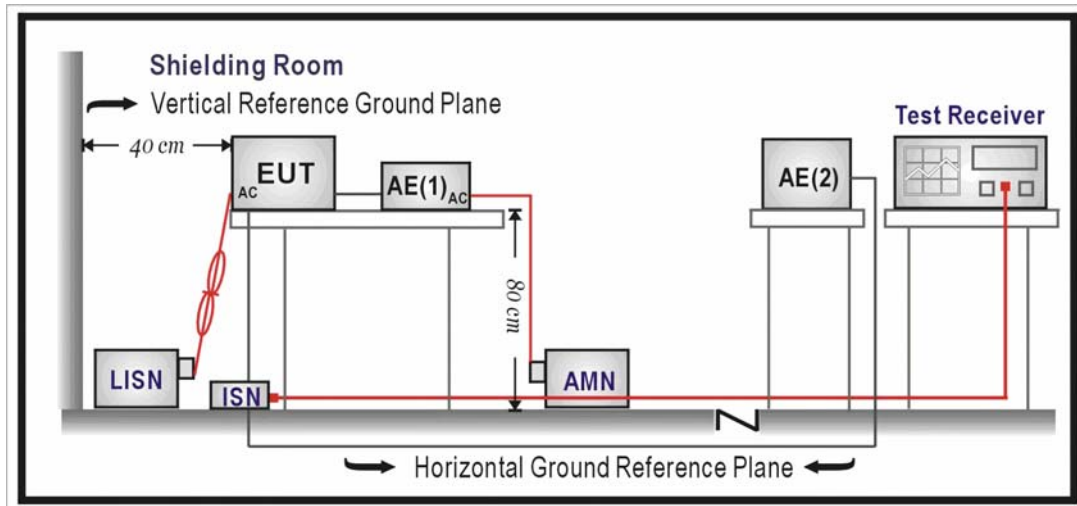

3.3. Limit

Limits		
Frequency (MHz)	QP (dBuV)	AV (dBuV)
0.15 - 0.50	97 – 87	84 – 74
0.50 - 30	87	74

Remarks:

The limit decreases linearly with the logarithm of the frequency in the range 0.15 MHz~0.50 MHz.

3.4. Test Procedure

Telecommunication Port:

The mains voltage shall be supplied to the EUT via the LISN when the measurement of telecommunication port is performed. The common mode disturbances at the telecommunication port shall be connected to the ISN, which is 150 ohm impedance.

Both alternative cables are tested related to the LCL requested. The measurement range is from 150kHz to 30MHz. The bandwidth of measurement is set to 9kHz.

The 60dB LCL ISN is used for cat. 5 cable, 50dB LCL ISN is used for cat. 3 and 80dB LCL is used for alternative one.

3.5. Deviation from Test Standard

No deviation.

3.6. Test Result

Site : SR-1	Time : 2006/04/14 - 11:14
Limit : ISN_Voltage_A_10db_00M_QP	Margin : 10
EUT : Ether Device Switch	Probe : - Line1
Power : AC 230V/50 Hz	Note : ISN-100Mbps

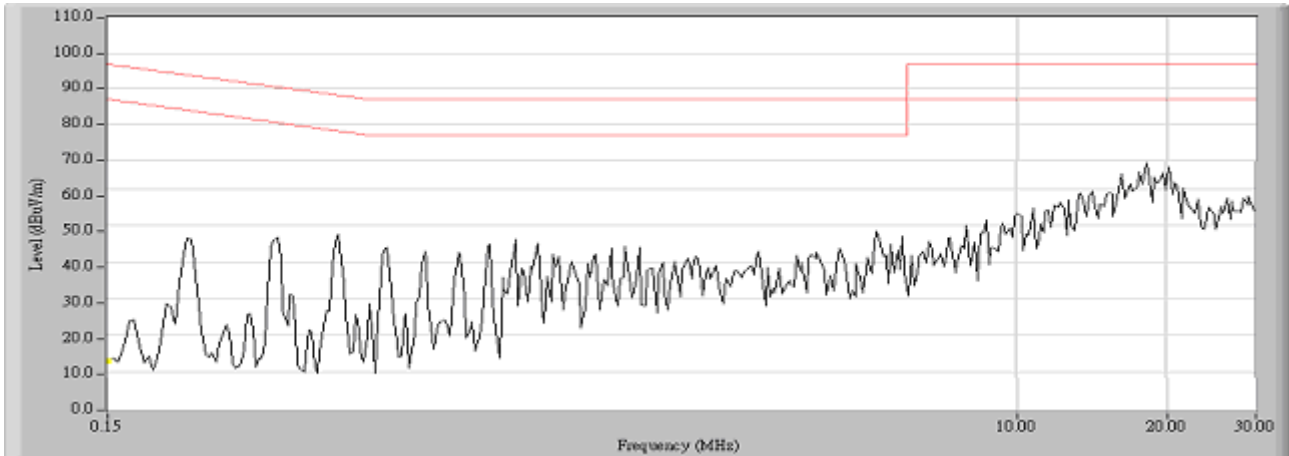

Site : SR-1	Time : 2006/04/14 - 11:07
Limit : ISN_Voltage_A_10db_00M_QP	Margin : 0
EUT : Ether Device Switch	Probe : ISN-T400 - Line1
Power : AC 230V/50 Hz	Note : ISN-100Mbps

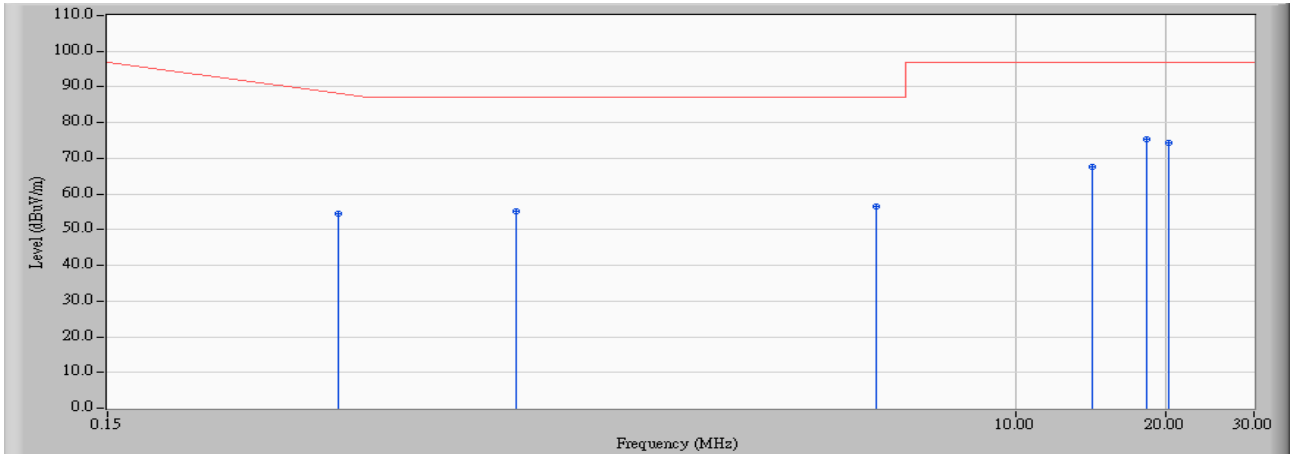

		Frequency (MHz)	Correct Factor (dB)	Reading Level (dBuV)	Measure Level (dBuV)	Margin (dB)	Limit (dBuV)	Detector Type
1		0.435	9.775	44.600	54.375	-34.482	88.857	QUASIPeAK
2		0.990	9.733	45.580	55.313	-31.687	87.000	QUASIPeAK
3		5.236	9.770	46.730	56.500	-30.500	87.000	QUASIPeAK
4		14.212	9.839	57.840	67.679	-29.321	97.000	QUASIPeAK
5	*	18.244	9.863	65.340	75.203	-21.797	97.000	QUASIPeAK
6		20.259	9.880	64.420	74.300	-22.700	97.000	QUASIPeAK

Note:

1. All Reading Levels are Quasi-Peak and average value.
2. " * ", means this data is the worst emission level.
3. Measurement Level = Reading Level + Correct Factor

Site : SR-1	Time : 2006/04/14 - 11:09
Limit : ISN_Voltage_A_10db_00M_AV	Margin : 0
EUT : Ether Device Switch	Probe : ISN-T400 - Line1
Power : AC 230V/50 Hz	Note : ISN-100Mbps

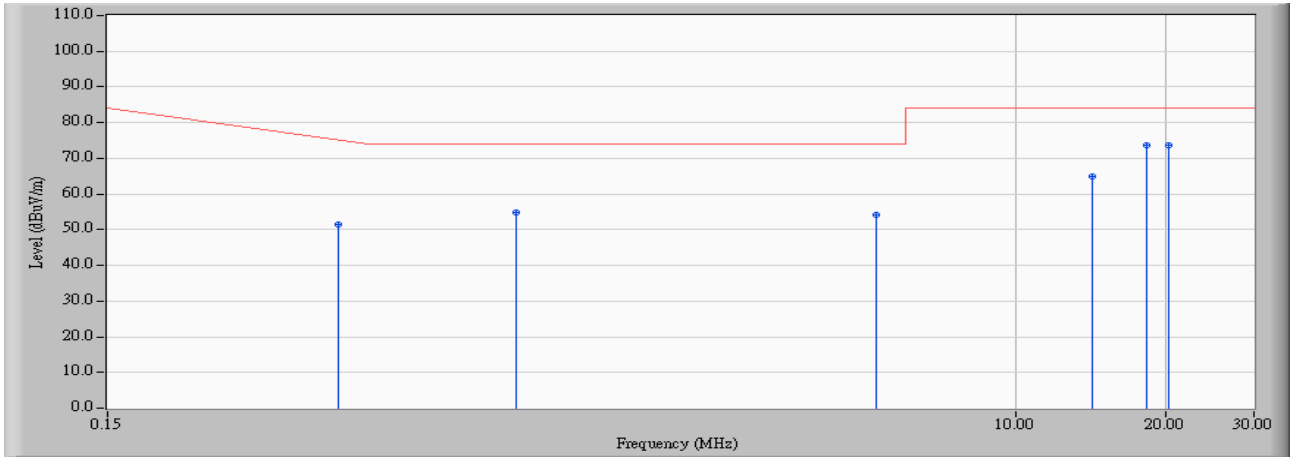

		Frequency (MHz)	Correct Factor (dB)	Reading Level (dBuV)	Measure Level (dBuV)	Margin (dB)	Limit (dBuV)	Detector Type
1		0.435	9.775	41.840	51.616	-24.242	75.857	AVERAGE
2		0.990	9.733	45.000	54.733	-19.267	74.000	AVERAGE
3		5.236	9.770	44.510	54.280	-19.720	74.000	AVERAGE
4		14.212	9.839	55.200	65.039	-18.961	84.000	AVERAGE
5	*	18.244	9.863	63.830	73.693	-10.307	84.000	AVERAGE
6		20.259	9.880	63.720	73.600	-10.400	84.000	AVERAGE

Note:

1. All Reading Levels are Quasi-Peak and average value.
2. " * ", means this data is the worst emission level.
3. Measurement Level = Reading Level + Correct Factor

Site : SR-1	Time : 2006/04/14 - 11:15
Limit : ISN_Voltage_A_10db_00M_QP	Margin : 10
EUT : Ether Device Switch	Probe : - Line1
Power : AC 230V/50 Hz	Note : ISN-10Mbps

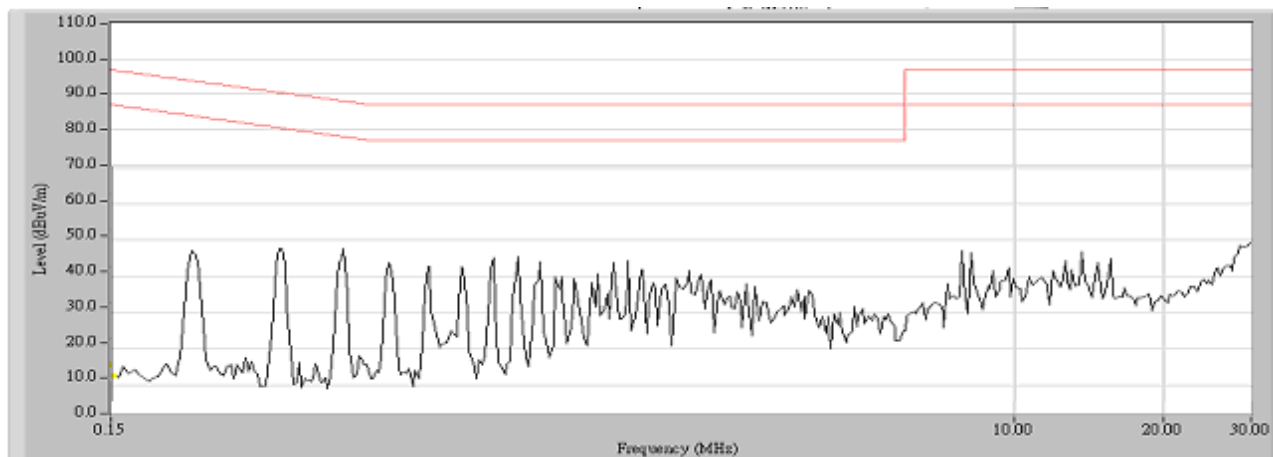

Site : SR-1	Time : 2006/04/14 - 11:11
Limit : ISN_Voltage_A_10db_00M_QP	Margin : 0
EUT : Ether Device Switch	Probe : ISN-T400 - Line1
Power : AC 230V/50 Hz	Note : ISN-10Mbps

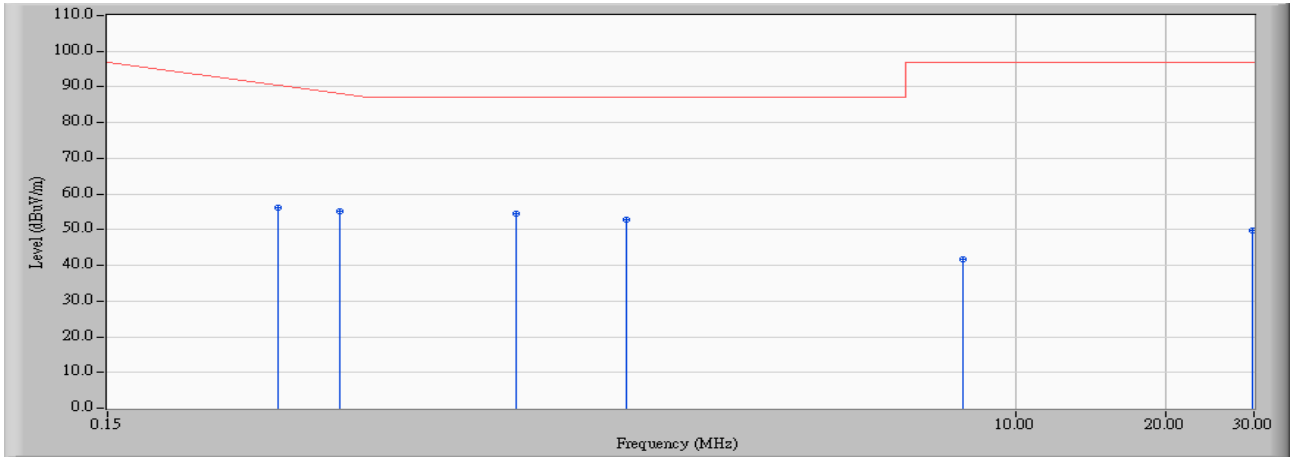

		Frequency (MHz)	Correct Factor (dB)	Reading Level (dBuV)	Measure Level (dBuV)	Margin (dB)	Limit (dBuV)	Detector Type
1		0.330	9.784	46.430	56.214	-35.643	91.857	QUASIPeAK
2		0.439	9.776	45.450	55.226	-33.517	88.743	QUASIPeAK
3	*	0.990	9.733	44.770	54.503	-32.497	87.000	QUASIPeAK
4		1.654	9.742	42.910	52.652	-34.348	87.000	QUASIPeAK
5		7.832	9.794	31.840	41.634	-55.366	97.000	QUASIPeAK
6		29.716	9.997	39.790	49.787	-47.213	97.000	QUASIPeAK

Note:

1. All Reading Levels are Quasi-Peak and average value.
2. " * ", means this data is the worst emission level.
3. Measurement Level = Reading Level + Correct Factor

Site : SR-1	Time : 2006/04/14 - 11:12
Limit : ISN_Voltage_A_10db_00M_AV	Margin : 0
EUT : Ether Device Switch	Probe : ISN-T400 - Line1
Power : AC 230V/50 Hz	Note : ISN-10Mbps

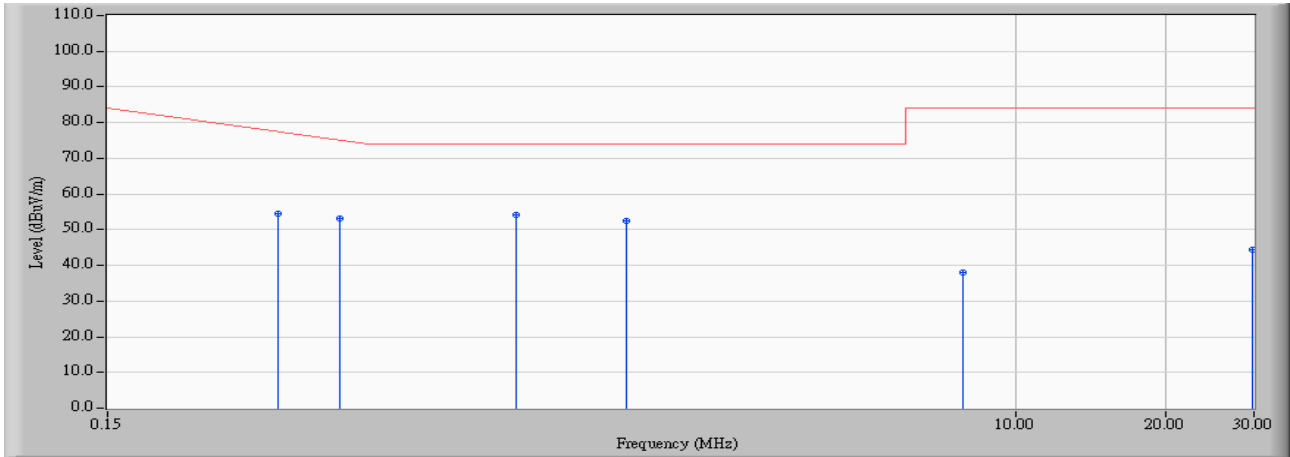

		Frequency (MHz)	Correct Factor (dB)	Reading Level (dBuV)	Measure Level (dBuV)	Margin (dB)	Limit (dBuV)	Detector Type
1		0.330	9.784	44.820	54.604	-24.253	78.857	AVERAGE
2		0.439	9.776	43.510	53.286	-22.457	75.743	AVERAGE
3	*	0.990	9.733	44.540	54.273	-19.727	74.000	AVERAGE
4		1.654	9.742	42.900	52.642	-21.358	74.000	AVERAGE
5		7.832	9.794	28.270	38.064	-45.936	84.000	AVERAGE
6		29.716	9.997	34.310	44.307	-39.693	84.000	AVERAGE

Note:

1. All Reading Levels are Quasi-Peak and average value.
2. " * ", means this data is the worst emission level.
3. Measurement Level = Reading Level + Correct Factor

3.7. Test Photograph

Test Mode : Mode 1:Normal Operation(fiber optics)

Description : Front View of ISN Test



Test Mode : Mode 1:Normal Operation(fiber optics)

Description : Back View of ISN Test



4. Radiated Emission

4.1. Test Specification

According to EMC Standard : EN 55022

4.2. Test Setup

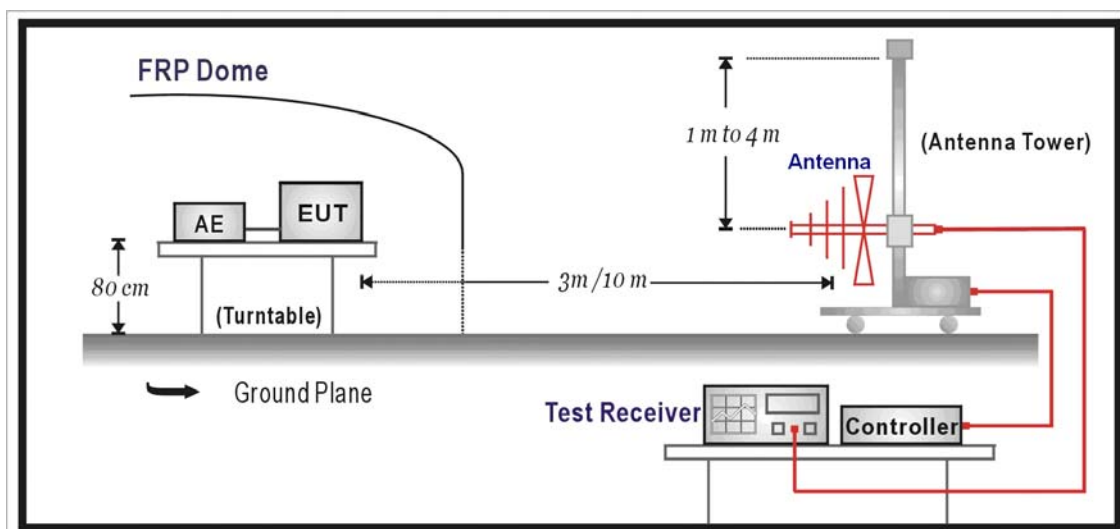

4.3. Limit

Limits		
Frequency MHz	Distance (m)	dBuV/m
30 – 230	10	40
230 – 1000	10	47

Remark:

1. The tighter limit shall apply at the edge between two frequency bands.
2. Distance refers to the distance in meters between the measuring instrument antenna and the closed point of any part of the device or system.

4.4. Test Procedure

The EUT and its simulators are placed on a turn table which is 0.8 meter above ground. The turn table can rotate 360 degrees to determine the position of the maximum emission level.

The EUT was positioned such that the distance from antenna to the EUT was 10 meters.

The antenna can move up and down between 1 meter and 4 meters to find out the maximum emission level.

Both horizontal and vertical polarization of the antenna are set on measurement. In order to find the maximum emission, all of the interface cables must be manipulated on radiated measurement.

Radiated emissions were investigated over the frequency range from 30MHz to 1GHz using a receiver bandwidth of 120kHz. Radiated was performed at an antenna to EUT distance of 10 meters.

4.5. Deviation from Test Standard

No deviation.

4.6. Test Result

Site : OATS-4	Time : 2006/04/06 - 14:26
Limit : CISPR_A_10M_QP	Margin : 6
EUT : Ether Device Switch	Probe : LKANT_S4_2006_01 - HORIZONTAL
Power : AC 230V/50Hz	Note : MODE 1

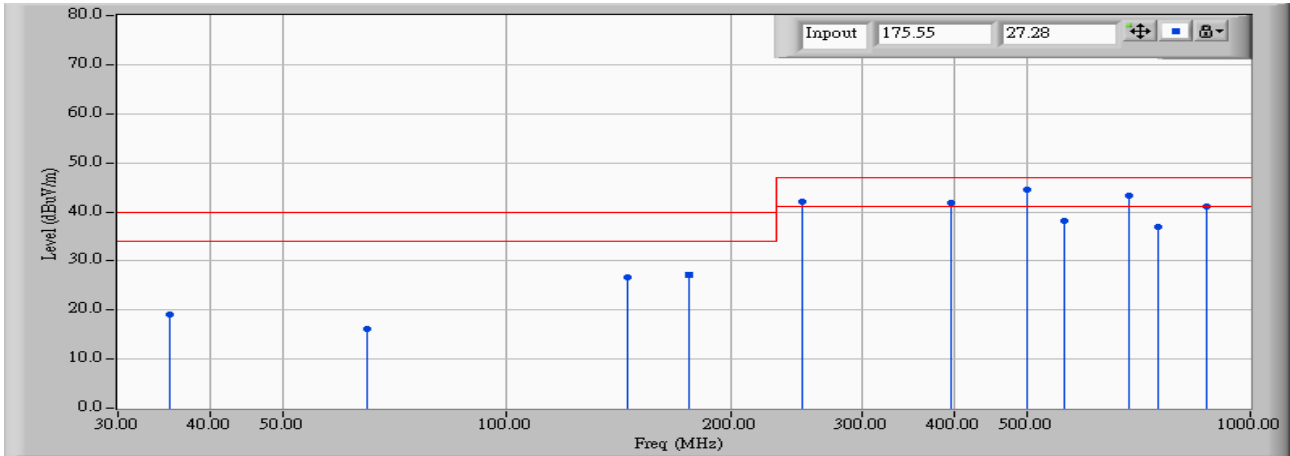

	Frequency (MHz)	Correct Factor (dB)	Reading Level (dBuV)	Measure Level (dBuV/m)	Margin (dB)	Limit (dBuV/m)	Detector Type
1	35.220	17.969	1.150	19.119	-20.881	40.000	QUASPEAK
2	64.775	8.205	7.880	16.085	-23.915	40.000	QUASPEAK
3	145.260	14.060	12.640	26.701	-13.299	40.000	QUASPEAK
4	175.548	12.548	14.730	27.278	-12.722	40.000	QUASPEAK
5	250.000	16.088	25.980	42.068	-4.932	47.000	QUASPEAK
6	396.000	20.139	21.600	41.740	-5.260	47.000	QUASPEAK
7	* 500.000	22.081	22.530	44.611	-2.389	47.000	QUASPEAK
8	562.495	23.240	14.910	38.149	-8.851	47.000	QUASPEAK
9	687.505	25.018	18.220	43.238	-3.762	47.000	QUASPEAK
10	750.008	25.780	11.120	36.900	-10.100	47.000	QUASPEAK
11	875.005	27.311	13.910	41.221	-5.779	47.000	QUASPEAK

Site : OATS-4	Time : 2006/04/06 - 14:13
Limit : CISPR_A_10M_QP	Margin : 6
EUT : Ether Device Switch	Probe : LKANT_S4_2006_01 - VERTICAL
Power : AC 230V/50Hz	Note : MODE 1

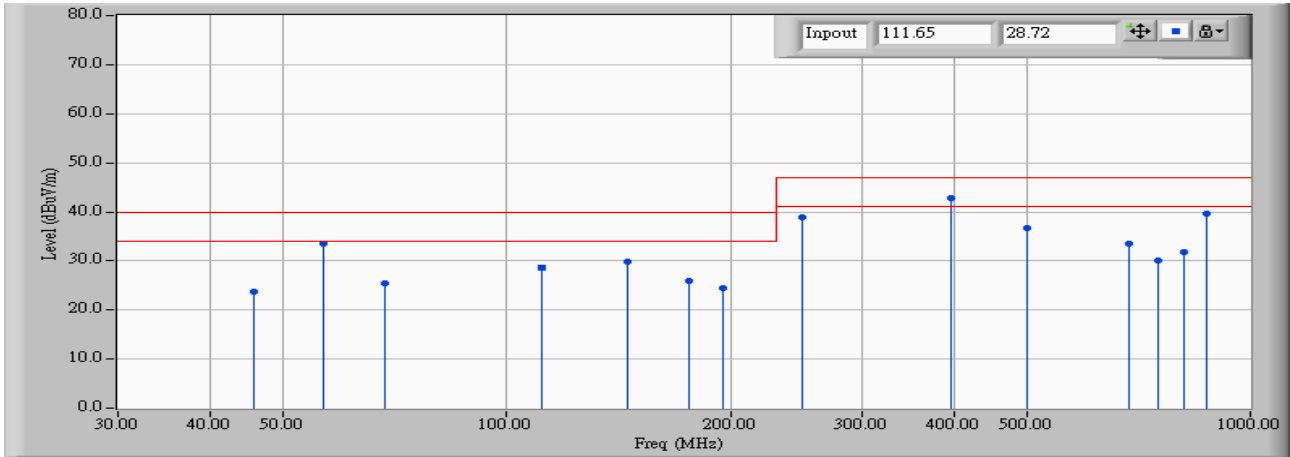

	Frequency (MHz)	Correct Factor (dB)	Reading Level (dBuV)	Measure Level (dBuV/m)	Margin (dB)	Limit (dBuV/m)	Detector Type
1	45.709	13.339	10.440	23.779	-16.221	40.000	QUASPEAK
2	56.764	8.791	24.660	33.451	-6.549	40.000	QUASPEAK
3	68.549	8.612	16.780	25.392	-14.608	40.000	QUASPEAK
4	111.649	13.827	14.890	28.718	-11.282	40.000	QUASPEAK
5	145.260	14.060	15.780	29.841	-10.159	40.000	QUASPEAK
6	175.426	12.552	13.270	25.822	-14.178	40.000	QUASPEAK
7	195.150	12.483	11.880	24.363	-15.637	40.000	QUASPEAK
8	250.000	16.088	22.820	38.908	-8.092	47.000	QUASPEAK
9	* 395.992	20.139	22.730	42.869	-4.131	47.000	QUASPEAK
10	500.005	22.081	14.710	36.791	-10.209	47.000	QUASPEAK
11	687.505	25.018	8.450	33.468	-13.532	47.000	QUASPEAK
12	750.008	25.780	4.380	30.160	-16.840	47.000	QUASPEAK
13	812.513	26.537	5.360	31.897	-15.103	47.000	QUASPEAK
14	875.005	27.311	12.370	39.681	-7.319	47.000	QUASPEAK

4.7. Test Photograph

Test Mode : Mode 1:Normal Operation(fiber optics)

Description : Front View of Radiated Test



Test Mode : Mode 1:Normal Operation(fiber optics)

Description : Back View of Radiated Test

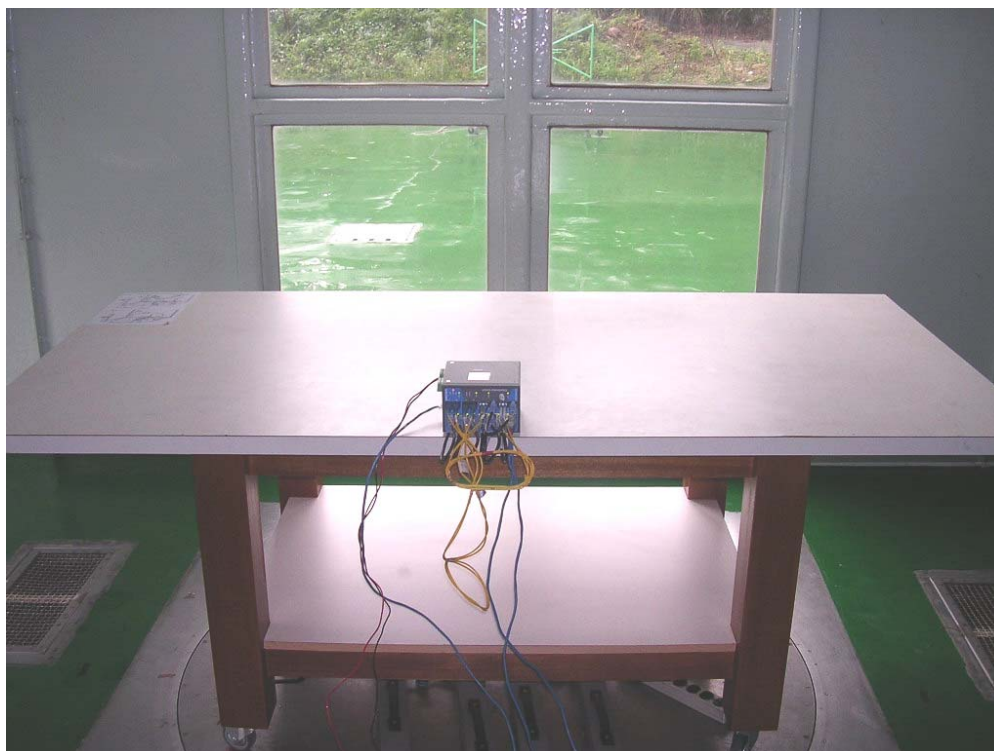

5. Electrostatic Discharge

5.1. Test Specification

According to Standard : IEC 61000-4-2

5.2. Test Setup

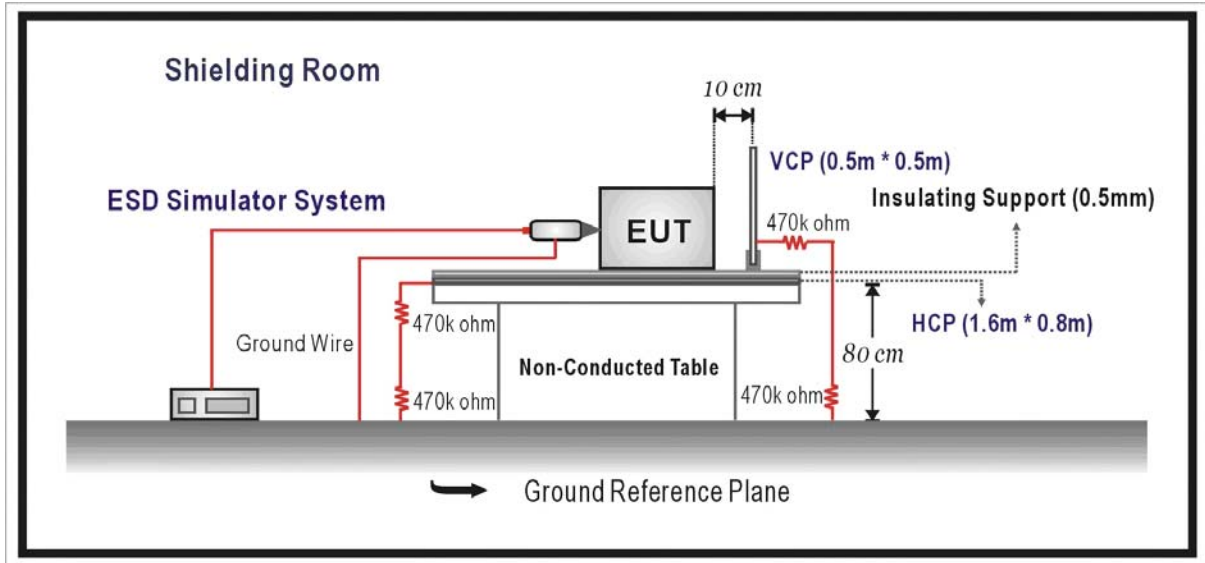

5.3. Limit

Item	Environmental Phenomena	Units	Test Specification	Performance Criteria
Enclosure Port				
	Electrostatic Discharge	kV(Charge Voltage)	±8 Air Discharge ±4 Contact Discharge	B

5.4. Test Procedure

Direct application of discharges to the EUT:

Contact discharge was applied only to conductive surfaces of the EUT.

Air discharges were applied only to non-conductive surfaces of the EUT.

During the test, it was performed with single discharges. For the single discharge time between successive single discharges will be keep longer 1 second. It was at least ten single discharges with positive and negative at the same selected point.

The selected point, which was performed with electrostatic discharge, was marked on the red label of the EUT.

Indirect application of discharges to the EUT:

Vertical Coupling Plane (VCP):

The coupling plane, of dimensions 0.5m x 0.5m, is placed parallel to, and positioned at a distance 0.1m from, the EUT, with the Discharge Electrode touching the coupling plane.

The four faces of the EUT will be performed with electrostatic discharge. It was at least ten single discharges with positive and negative at the same selected point.

Horizontal Coupling Plane (HCP):

The coupling plane is placed under to the EUT. The generator shall be positioned vertically at a distance of 0.1m from the EUT, with the Discharge Electrode touching the coupling plane.

The four faces of the EUT will be performed with electrostatic discharge. It was at least ten single discharges with positive and negative at the same selected point.

5.5. Deviation from Test Standard

No deviation.

5.6. Test Result

Product	Ether Device Switch		
Test Item	Electrostatic Discharge		
Test Mode	Mode 1:Normal Operation(fiber optics)		
Date of Test	2006/04/11	Test Site	No.3 Shielded Room

Item	Amount of Discharge	Voltage	Required Criteria	Complied To Criteria (A,B,C)	Results
Air Discharge	10	+8kV	B	A	Pass
	10	-8kV	B	A	Pass
Contact Discharge	25	+4kV	B	A	Pass
	25	-4kV	B	A	Pass
Indirect Discharge (HCP)	50	+4kV	B	A	Pass
	50	-4kV	B	A	Pass
Indirect Discharge (VCP Front)	50	+4kV	B	A	Pass
	50	-4kV	B	A	Pass
Indirect Discharge (VCP Left)	50	+4kV	B	A	Pass
	50	-4kV	B	A	Pass
Indirect Discharge (VCP Back)	50	+4kV	B	A	Pass
	50	-4kV	B	A	Pass
Indirect Discharge (VCP Right)	50	+4kV	B	A	Pass
	50	-4kV	B	A	Pass

Note:

The testing performed is from lowest level up to the highest level as required by standard, but only highest level is shown on the report.

NR: No Requirement

- Meet criteria A: Operate as intended during and after the test
- Meet criteria B: Operate as intended after the test
- Meet criteria C: Loss/Error of function
- Additional Information
 - EUT stopped operation and could / could not be reset by operator at ____ kV.
 - No false alarms or other malfunctions were observed during or after the test.

Remark:

The Contact discharges were applied at least total 200 discharges at a minimum of four test points.

5.7. Test Photograph

Test Mode : Mode 1:Normal Operation(fiber optics)

Description : ESD Test Setup

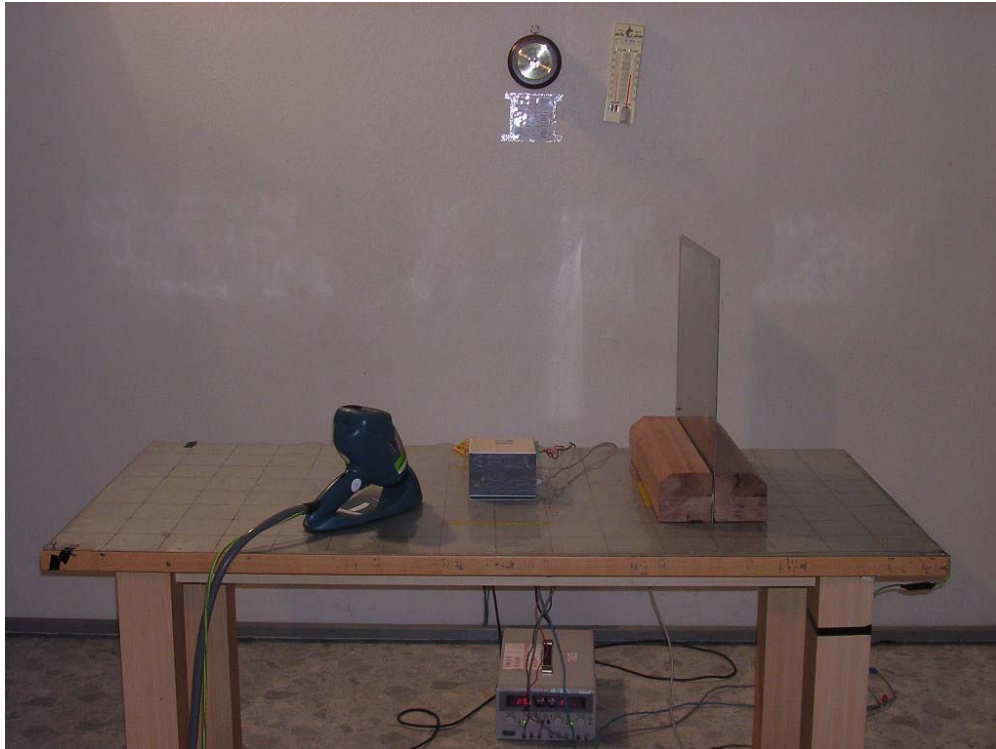

6. Radiated Susceptibility

6.1. Test Specification

According to Standard : IEC 61000-4-3

6.2. Test Setup

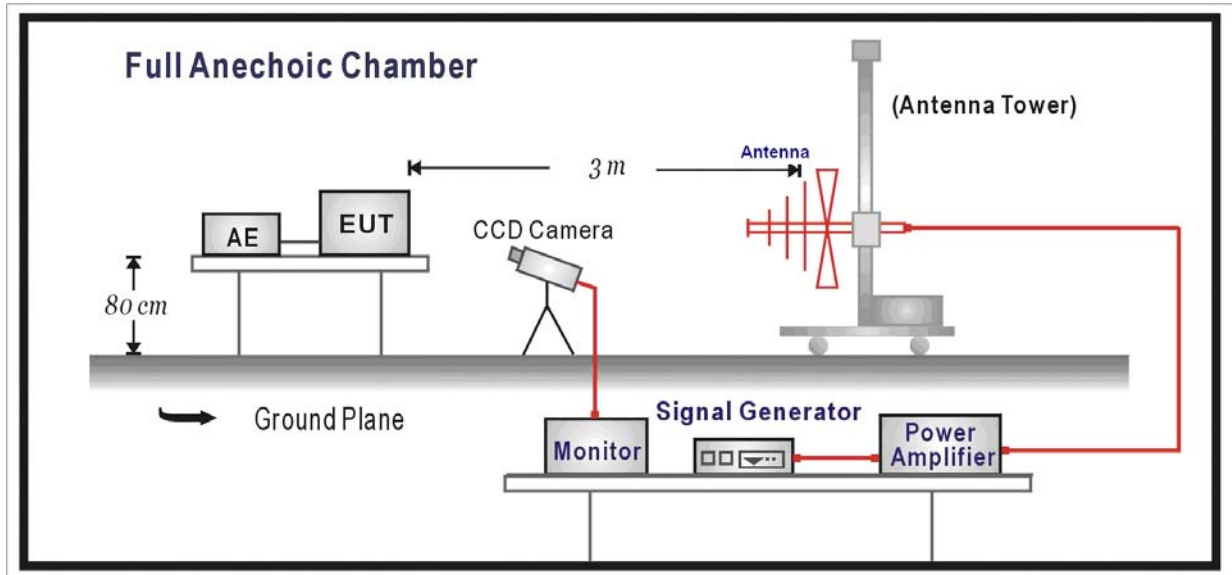

6.3. Limit

Item	Environmental Phenomena	Units	Test Specification	Performance Criteria
Enclosure Port				
	Radio-Frequency	MHz	80-1000	A
	Electromagnetic Field	V/m(Un-modulated, rms)	10	
	Amplitude Modulated	% AM (1kHz)	80	

6.4. Test Procedure

The EUT and load, which are placed on a table that is 0.8 meter above ground, are placed with one coincident with the calibration plane such that the distance from antenna to the EUT was 3 meters.

Both horizontal and vertical polarization of the antenna and four sides of the EUT are set on measurement.

In order to judge the EUT performance, a CCD camera is used to monitor EUT screen.

All the scanning conditions are as follows:

Condition of Test	Remarks
1. Field Strength	10 V/m Level 3
2. Radiated Signal	AM 80% Modulated with 1kHz
3. Scanning Frequency	80MHz - 1000MHz
4. Dwell Time	3 Seconds
5. Frequency step size Δf :	1%
6. The rate of Swept of Frequency	1.5×10^{-3} decades/s

6.5. Deviation from Test Standard

No deviation.

6.6. Test Result

Product	Ether Device Switch		
Test Item	Radiated susceptibility		
Test Mode	Mode 1:Normal Operation(fiber optics)		
Date of Test	2006/04/13	Test Site	Chamber5

Frequency (MHz)	Position (Angle)	Polarity (H or V)	Field Strength (V/m)	Required Criteria	Complied To Criteria (A,B,C)	Results
80-1000	FRONT	H	10	A	A	PASS
80-1000	FRONT	V	10	A	A	PASS
80-1000	BACK	H	10	A	A	PASS
80-1000	BACK	V	10	A	A	PASS
80-1000	RIGHT	H	10	A	A	PASS
80-1000	RIGHT	V	10	A	A	PASS
80-1000	LEFT	H	10	A	A	PASS
80-1000	LEFT	V	10	A	A	PASS
80-1000	UP	H	10	A	A	PASS
80-1000	UP	V	10	A	A	PASS
80-1000	DOWN	H	10	A	A	PASS
80-1000	DOWN	V	10	A	A	PASS

Note:

The testing performed is from lowest level up to the highest level as required by standard, but only highest level is shown on the report.

- Meet criteria A: Operate as intended during and after the test
- Meet criteria B: Operate as intended after the test
- Meet criteria C: Loss/Error of function
- Additional Information
 - There was no observable degradation in performance.
 - EUT stopped operation and could / could not be reset by operator at _____ V/m at frequency _____ MHz.
- No false alarms or other malfunctions were observed during or after the test.

6.7. Test Photograph

Test Mode : Mode 1:Normal Operation(fiber optics)

Description : Radiated Susceptibility Test Setup

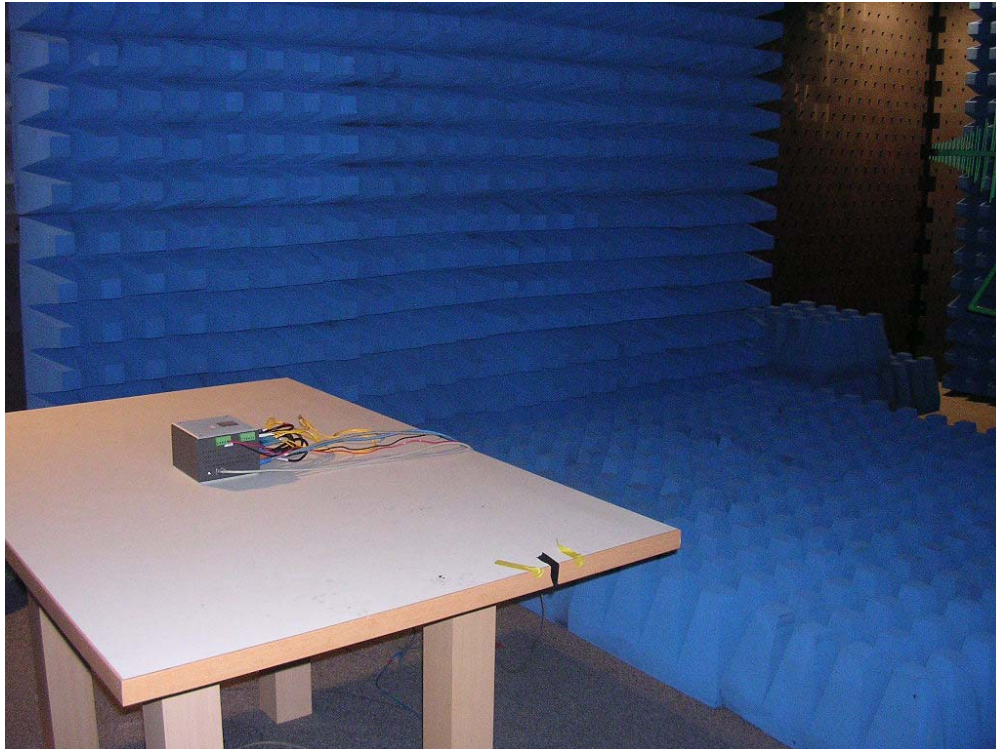

7. Electrical Fast Transient/Burst

7.1. Test Specification

According to Standard : IEC 61000-4-4

7.2. Test Setup

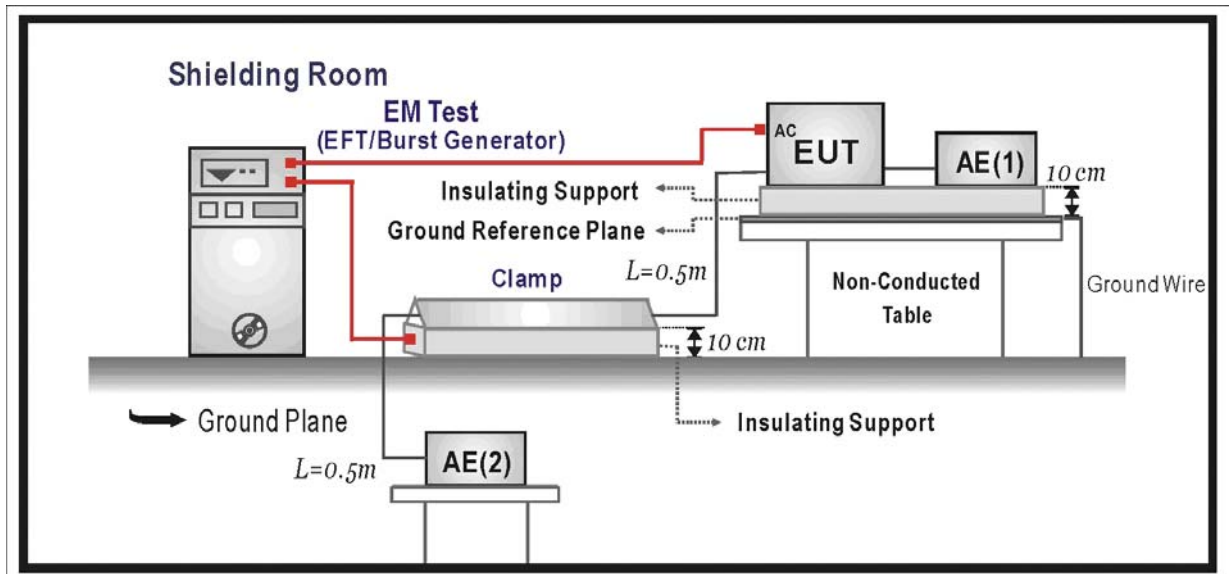

7.3. Limit

Item	Environmental Phenomena	Units	Test Specification	Performance Criteria
I/O and communication ports				
	Fast Transients Common Mode	kV (Peak) Tr/Th ns Rep. Frequency kHz	+0.5 5/50 5	B
Input DC Power Ports				
	Fast Transients Common Mode	kV (Peak) Tr/Th ns Rep. Frequency kHz	+0.5 5/50 5	B
Input AC Power Ports				
	Fast Transients Common Mode	kV (Peak) Tr/Th ns Rep. Frequency kHz	+1 5/50 5	B

7.4. Test Procedure

The EUT is placed on a table that is 0.8 meter height. A ground reference plane is placed on the table, and uses a 0.1m insulation between the EUT and ground reference plane.

The minimum area of the ground reference plane is 1m*1m, and 0.65mm thick min, and projected beyond the EUT by at least 0.1m on all sides.

Test on I/O and communication ports:

The EFT interference signal is through a coupling clamp device couples to the signal and control lines of the EUT with burst noise for 1minute.

Test on power supply ports:

The EUT is connected to the power mains through a coupling device that directly couples the EFT/B interference signal.

Each of the Line and Neutral conductors is impressed with burst noise for 1 minute.

The length of the signal and power lines between the coupling device and the EUT is 0.5m.

7.5. Deviation from Test Standard

No deviation.

7.6. Test Result

Product	Ether Device Switch		
Test Item	Electrical fast transient/burst		
Test Mode	Mode 1:Normal Operation(fiber optics)		
Date of Test	2006/03/21	Test Site	No.2 Shielded Room

Inject Line	Polarity	Voltage kV	Inject Time (Second)	Inject Method	Required Criteria	Complied to Criteria	Result
L+N+PE	±	1kV	60	CDN	B	A	PASS
LAN	±	0.5 kV	90	Clamp	B	A	PASS

Note:

The testing performed is from lowest level up to the highest level as required by standard, but only highest level is shown on the report.

- Meet criteria A : Operate as intended during and after the test
- Meet criteria B : Operate as intended after the test
- Meet criteria C : Loss/Error of function
- Additional Information
 - EUT stopped operation and could / could not be reset by operator at _____ kV of Line _____.
- No false alarms or other malfunctions were observed during or after the test.

7.7. Test Photograph

Test Mode : Mode 1:Normal Operation(fiber optics)

Description : EFT/B Test Setup



Test Mode : Mode 1:Normal Operation(fiber optics)

Description : EFT/B Test Setup-Clamp



8. Surge

8.1. Test Specification

According to Standard : IEC 61000-4-5

8.2. Test Setup

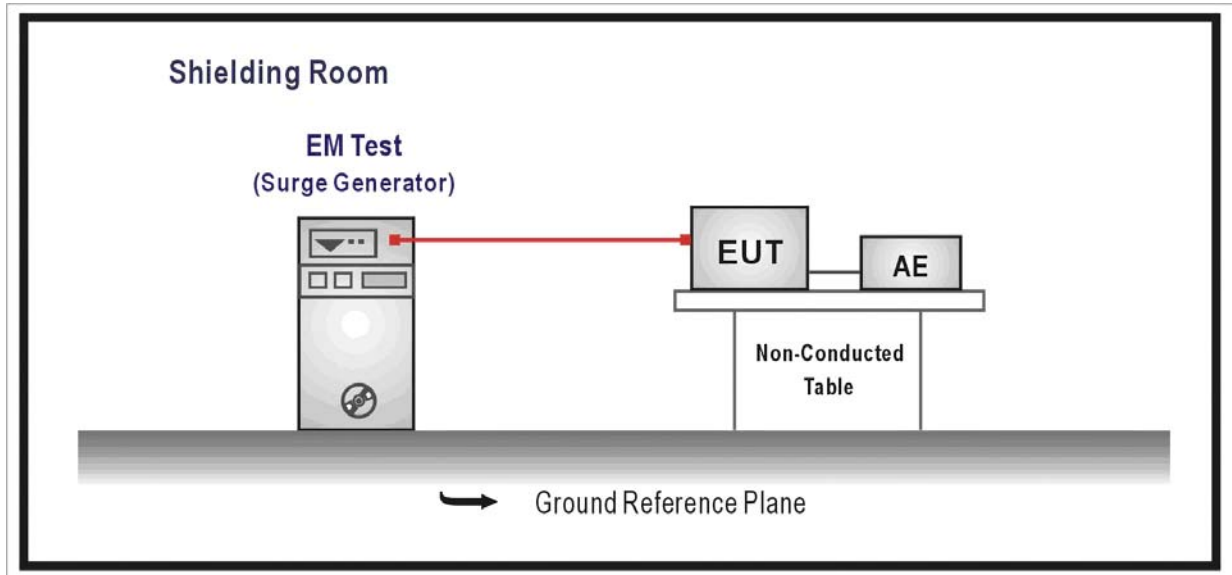

8.3. Limit

Item	Environmental Phenomena	Units	Test Specification	Performance Criteria
Signal Ports and Telecommunication Ports(See 1) and 2))				
	Surges Line to Ground	Tr/Th us kV	1.2/50 (8/20) ± 1	B
Input DC Power Ports				
	Surges Line to Ground	Tr/Th us kV	1.2/50 (8/20) ± 0.5	B
AC Input and AC Output Power Ports				
	Surges Line to Line Line to Ground	Tr/Th us kV kV	1.2/50 (8/20) ± 1 ± 2	B

Notes:

- 1) Applicable only to ports which according to the manufacturer’s may directly to outdoor cables.
- 2) Where normal functioning cannot be achieved because of the impact of the CDN on the EUT, no immunity test shall be required.

8.4. Test Procedure

The EUT and its load are placed on a table that is 0.8 meter above a metal ground plane measured 1m*1m min. and 0.65mm thick min. And projected beyond the EUT by at least 0.1m on all sides. The length of power cord between the coupling device and the EUT shall be 2m or less.

For Input and Output AC Power or DC Input and DC Output Power Ports:

The EUT is connected to the power mains through a coupling device that directly couples the Surge interference signal.

The surge noise shall be applied synchronized to the voltage phase at 0° , 90° , 180° , 270° and the peak value of the a.c. voltage wave. (Positive and negative)

Each of Line-Earth and Line-Line is impressed with a sequence of five surge voltages with interval of 1 min.

8.5. Deviation from Test Standard

No deviation.

8.6. Test Result

Product	Ether Device Switch		
Test Item	Surge		
Test Mode	Mode 1:Normal Operation(fiber optics)		
Date of Test	2006/03/21	Test Site	No.2 Shielded Room

Inject Line	Polarity	Voltage kV	Time Interval (Second)	Inject Method	Required Criteria	Complie d to Criteria	Result
L-N	±	1kV	60	Direct	B	A	PASS
L-N	±	1kV	60	Direct	B	A	PASS
L-N	±	1kV	60	Direct	B	B	PASS
L-N	±	1kV	60	Direct	B	B	PASS
L-PE	±	2kV	60	Direct	B	A	PASS
L-PE	±	2kV	60	Direct	B	A	PASS
L-PE	±	2kV	60	Direct	B	A	PASS
L-PE	±	2kV	60	Direct	B	A	PASS
N-PE	±	2kV	60	Direct	B	A	PASS
N-PE	±	2kV	60	Direct	B	A	PASS
N-PE	±	2kV	60	Direct	B	A	PASS
N-PE	±	2kV	60	Direct	B	A	PASS

Note:

The testing performed is from lowest level up to the highest level as required by standard, but only highest level is shown on the report.

- Meet criteria A : Operate as intended during and after the test
- Meet criteria B : Operate as intended after the test
- Meet criteria C : Loss/Error of function
- Additional Information
 - EUT stopped operation and could / could not be reset by operator at _____ kV of Line _____.
- No false alarms or other malfunctions were observed during or after the test.

8.7. Test Photograph

Test Mode : Mode 1:Normal Operation(fiber optics)

Description : SURGE Test Setup



9. Conducted Susceptibility

9.1. Test Specification

According to Standard : IEC 61000-4-6

9.2. Test Setup

CDN Test Mode

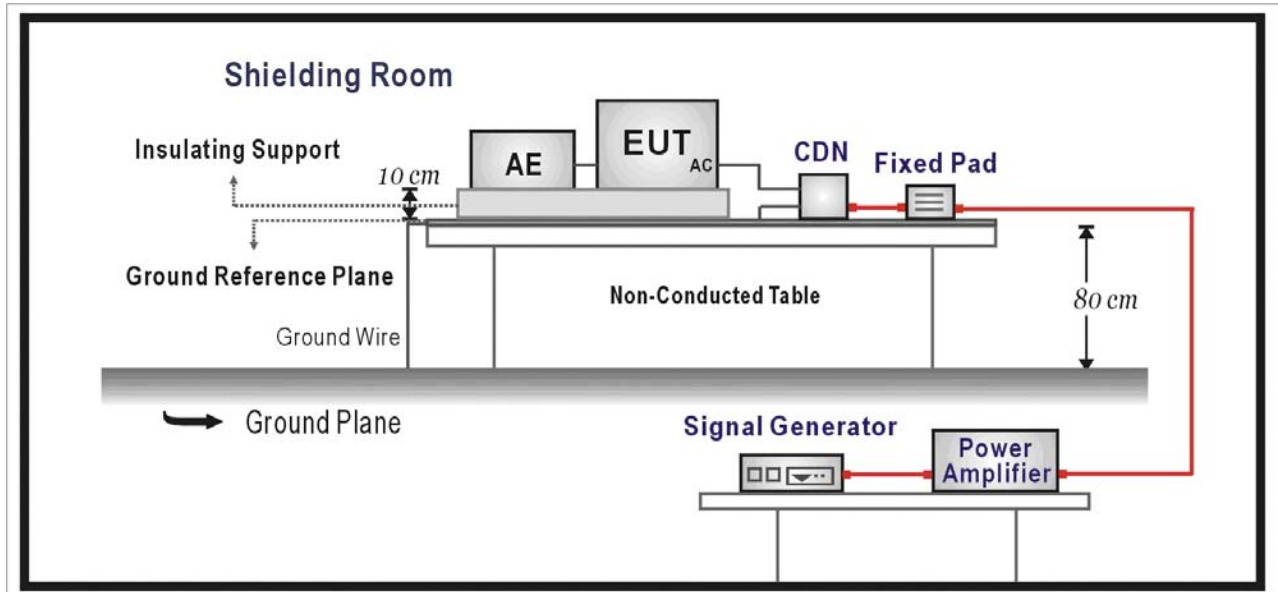

EM Clamp Test Mode

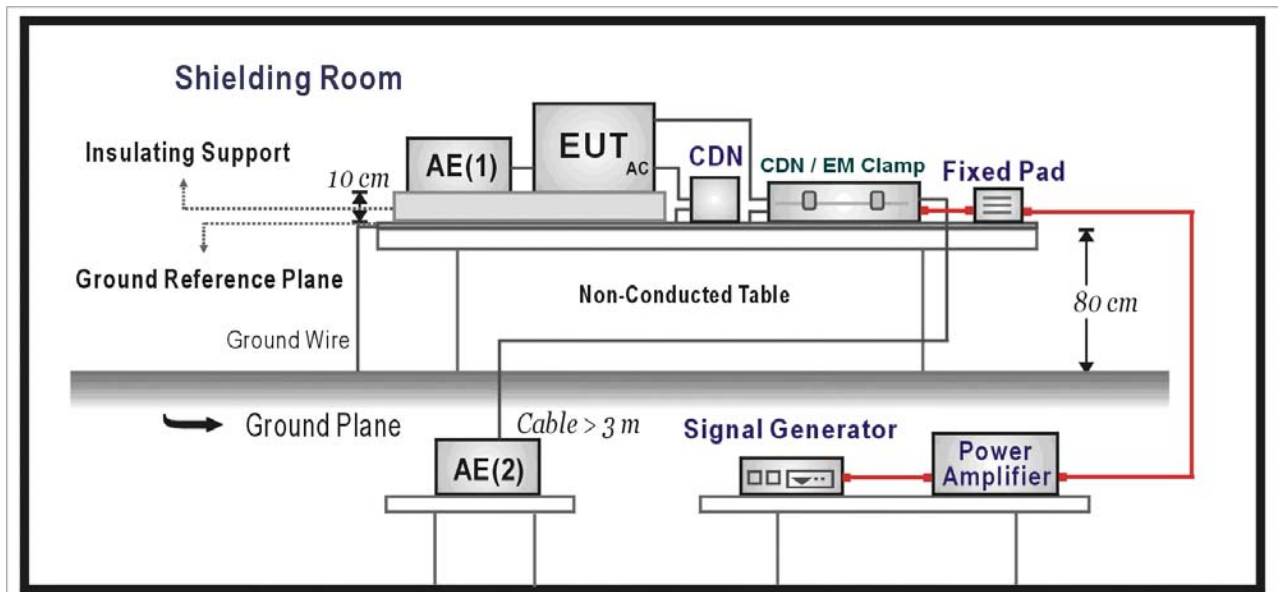

9.3. Limit

Item	Environmental Phenomena	Units	Test Specification	Performance Criteria
Signal Ports and Telecommunication Ports				
	Radio-Frequency Continuous Conducted	MHz V (rms, Un-modulated) % AM (1kHz)	0.15-80 10 80	A
Input DC Power Ports				
	Radio-Frequency Continuous Conducted	MHz V (rms, Un-modulated) % AM (1kHz)	0.15-80 10 80	A
Input AC Power Ports				
	Radio-Frequency Continuous Conducted	MHz V (rms, Un-modulated) % AM (1kHz)	0.15-80 10 80	A

9.4. Test Procedure

The EUT are placed on a table that is 0.8 meter height, and a Ground reference plane on the table, EUT are placed upon table and use a 10cm insulation between the EUT and Ground reference plane.

For Signal Ports and Telecommunication Ports

The disturbance signal is through a coupling and decoupling networks (CDN) or EM-clamp device couples to the signal and Telecommunication lines of the EUT.

For Input DC and AC Power Ports

The EUT is connected to the power mains through a coupling and decoupling networks for power supply lines. And directly couples the disturbances signal into EUT.

Used CDN-M2 for two wires or CDN-M3 for three wires.

All the scanning conditions are as follows:

Condition of Test	Remarks
1. Field Strength	130dBuV(10V) Level 3
2. Radiated Signal	AM 80% Modulated with 1kHz
3. Scanning Frequency	0.15MHz – 80MHz
4. Dwell Time	3 Seconds
5. Frequency step size Δf :	1%
6. The rate of Swept of Frequency	1.5×10^{-3} decades/s

9.5. Deviation from Test Standard

No deviation.

9.6. Test Result

Product	Ether Device Switch		
Test Item	Conducted susceptibility		
Test Mode	Mode 1:Normal Operation(fiber optics)		
Date of Test	2006/04/17	Test Site	No.6 Shielded Room

Frequency Range (MHz)	Voltage Applied dBuV(V)	Inject Method	Tested Port of EUT	Required Criteria	Performance Criteria Complied To	Result
0.15~80	130 (10V)	CDN03	AC IN	A	A	PASS
0.15~80	130 (10V)	CDN13	LAN	A	A	PASS

Note:

The testing performed is from lowest level up to the highest level as required by standard, but only highest level is shown on the report.

- Meet criteria A : Operate as intended during and after the test
- Meet criteria B : Operate as intended after the test
- Meet criteria C : Loss/Error of function
- Additional Information
 - EUT stopped operation and could / could not be reset by operator at _____ dBuV(V) at frequency _____MHz.
 - No false alarms or other malfunctions were observed during or after the test. The acceptance criteria were met, and the EUT passed the test.

9.7. Test Photograph

Test Mode : Mode 1:Normal Operation(fiber optics)

Description : Conducted Susceptibility Test Setup



Test Mode : Mode 1:Normal Operation(fiber optics)

Description : Conducted Susceptibility Test Setup



10. Attachment

➤ EUT Photograph

(1) EUT Photo



(2) EUT Photo



(3) EUT Photo



(4) EUT Photo



(5) EUT Photo



(6) EUT Photo



(7) EUT Photo



(8) EUT Photo



(9) EUT Photo



(10) EUT Photo



(11) EUT Photo



(12) EUT Photo



(13) EUT Photo

