

## DIN Rail Accessories

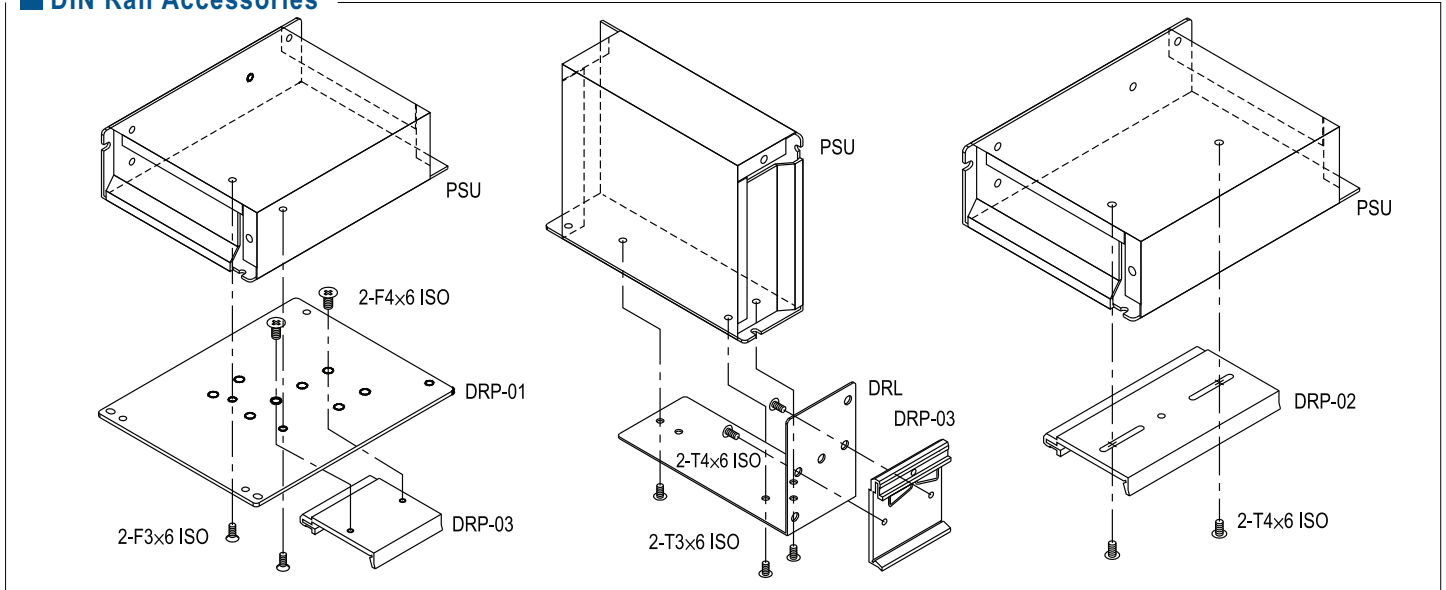

## Mounting Accessories

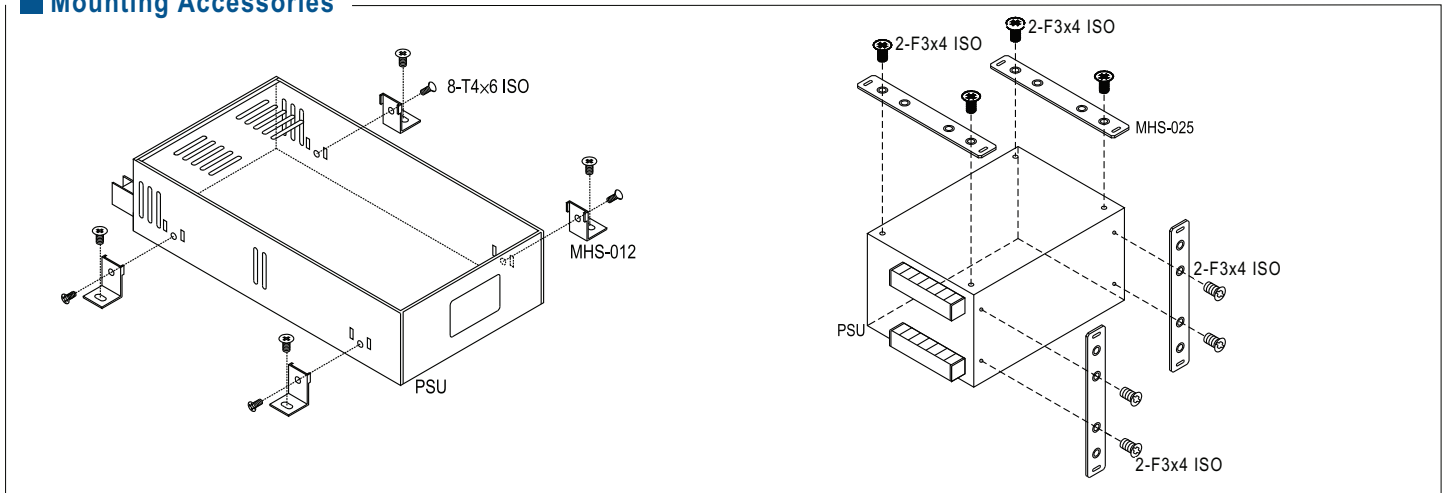

ITEM	Order No.	Case	Model
	DRL-01	903 905 931 932 971	S-40, D-30, T-30, ..... S-15, S-25, ..... RS-25, NES-15 RS-35, NES-25 RS-15
	DRL-02	901 902 906 915 916 920	S-50, S-60, D-60, ..... S-100, S-100F, SD-100, ..... S-150, SD-150, D-120, ..... SP-100, ..... SP-150, SP-200, ..... SP-75, .....
	DRL-03	911 912	S-240, ..... S-320, SP-320, .....
	DRL-03A	980 987	SP-240, HRP(G)-300
	DRP-01	901, 902 903, 906 912, 931 932	All models
	DRP-02	905 / 915 916 / 920 928	S-15, S-25, ... / SP-100, ... SP-150, SP-200, ... / SP-75, ... USP-225, .....
		DRP-03	DRP-01 DRL-01~03

ITEM	Order No.	Case	Model
	MHS012	912, 915 916, 935 939, 940 977, 980 987	S-201, S-320, S-350, SP-100, SP-150, SP-200, SP-320, SE-1000, MP450/650/1000, SP-240, HRP-300/600
	MHS013	919 926	PSP-500, SP-750, SE-600
	MHS014	952	RSP-1000, SD-1000
	MHS025	910	SP-500, PSP-600.....
	MHS026	943	RSP-1500
 <b>NEW</b>	TBC-05	901 903 905 932	SD-50 S-40, NES-50, RS-75 S-25, SD-25, NES-35, RS-50 S-60, NES-25, RS-35
	Cover for terminal block	TBC-07	901 902 902A 903 905 906
	TBC-08	901 906	AD-155, ADD/ADS-155 D/T/Q-120,

## 952B

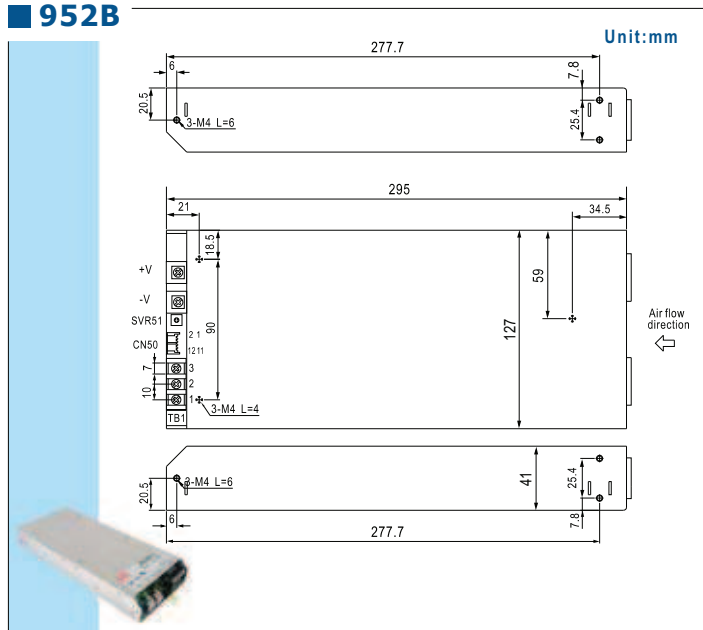

## 986

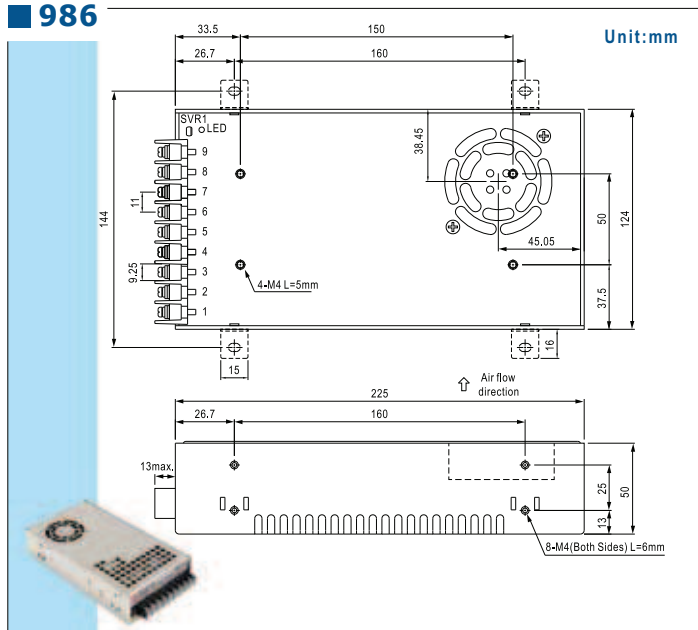

## 963

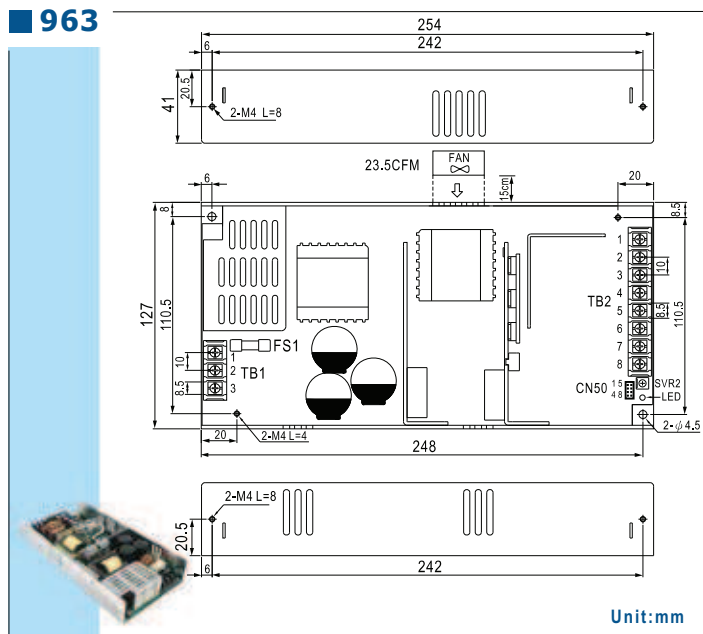

## 987A

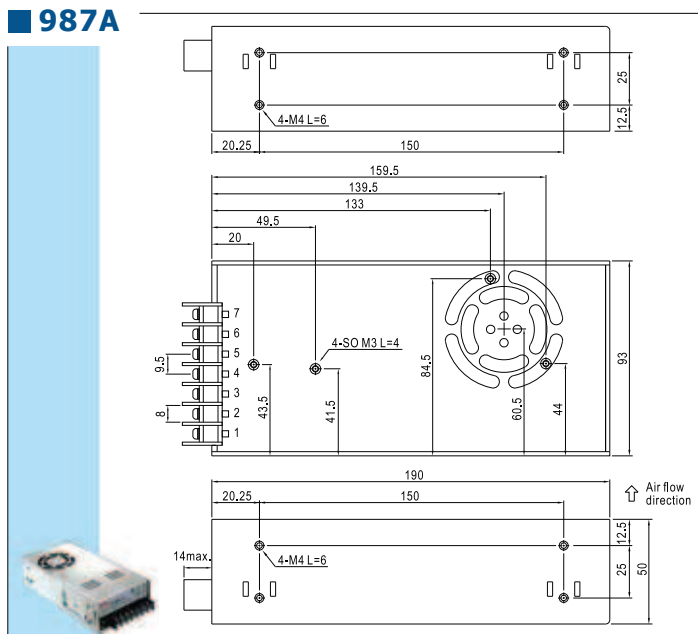

## 971A

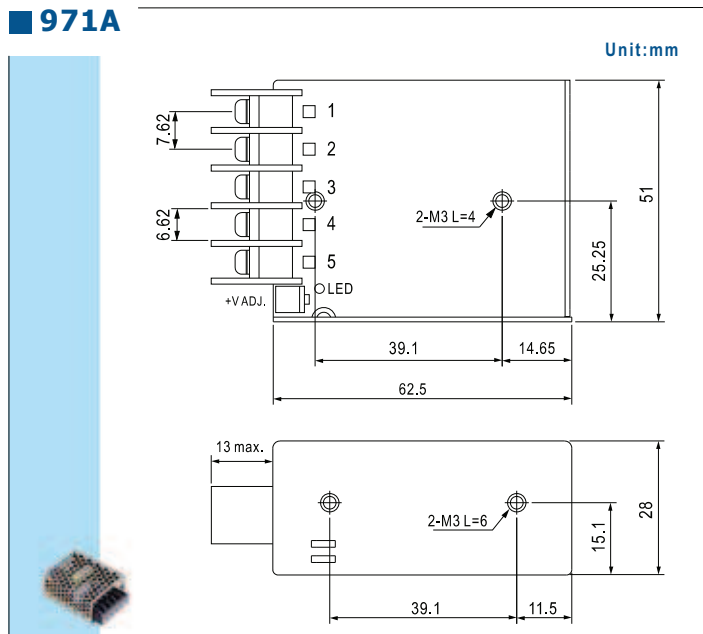

## 988A

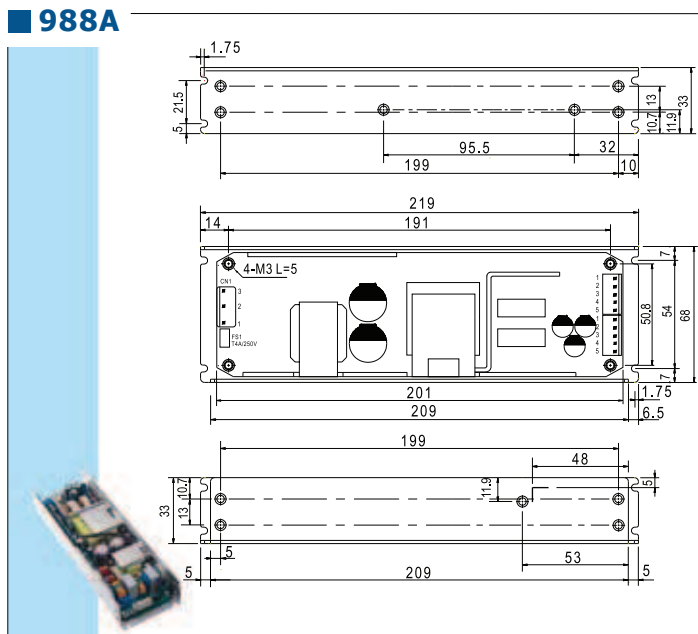

# Case Drawing

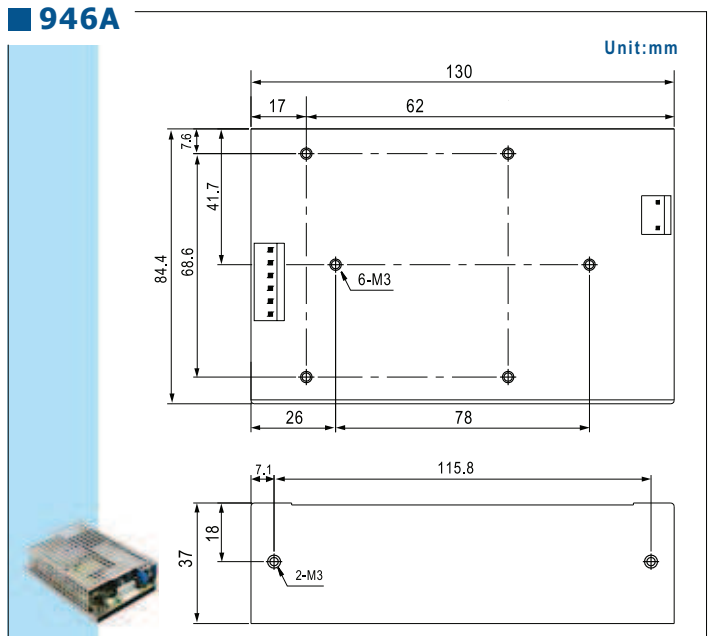
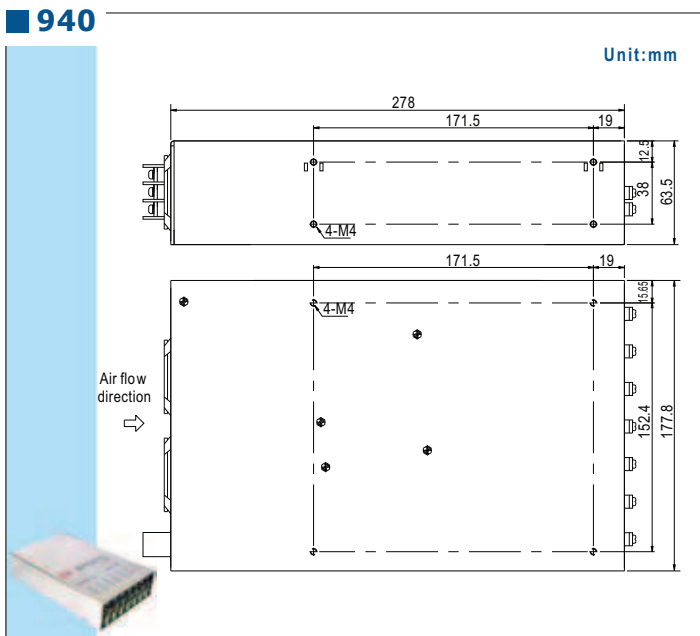
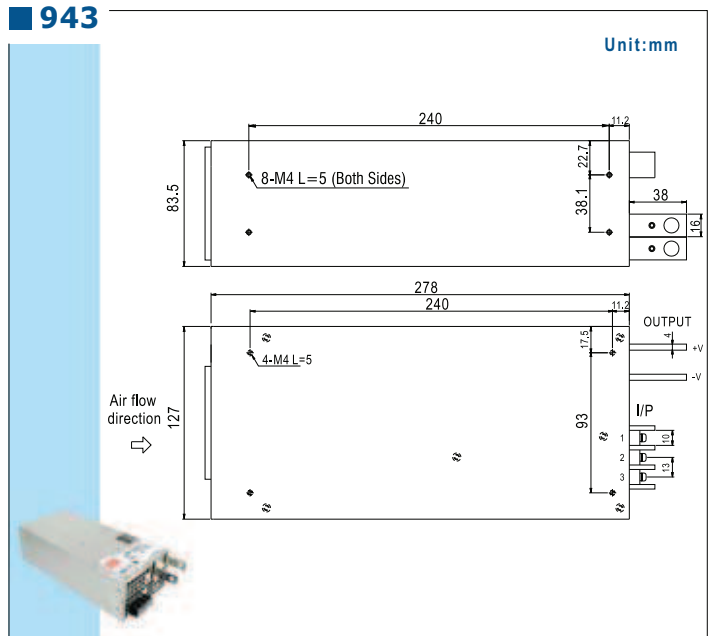
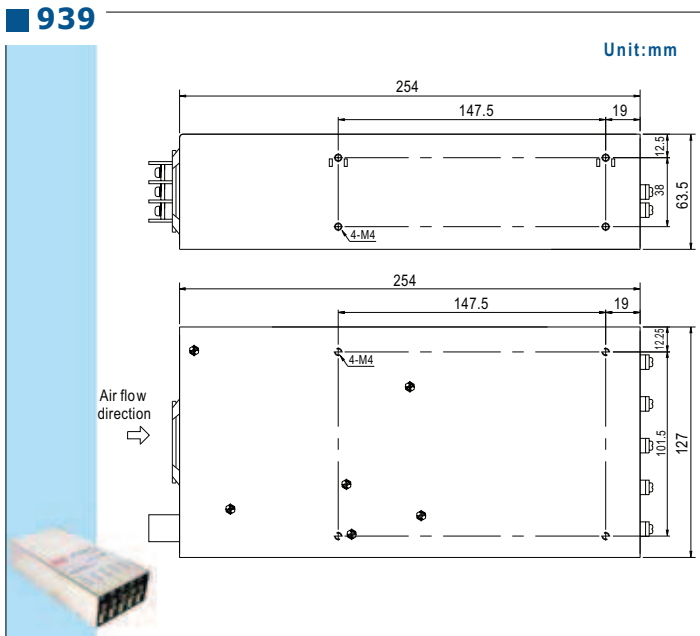
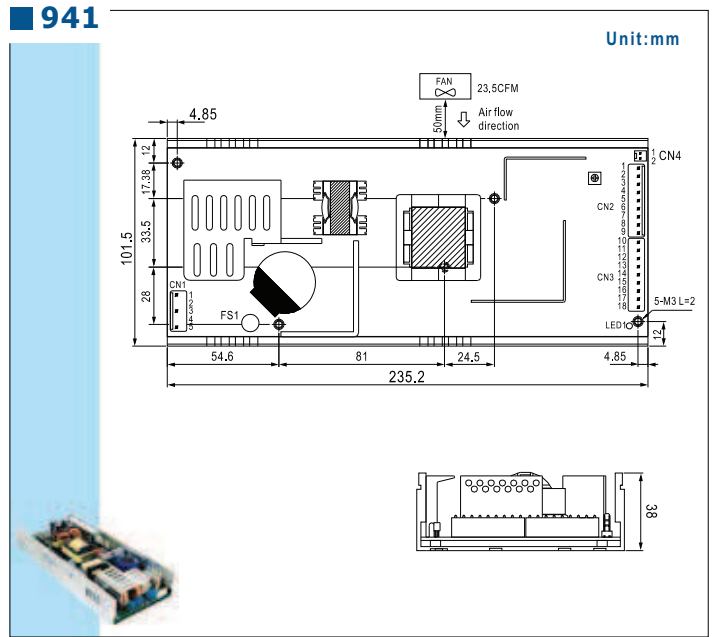
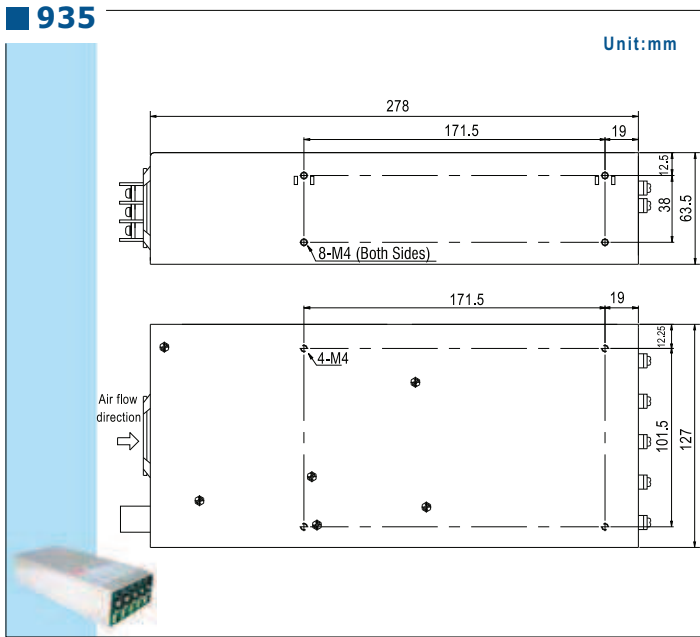

# Case Drawing

926

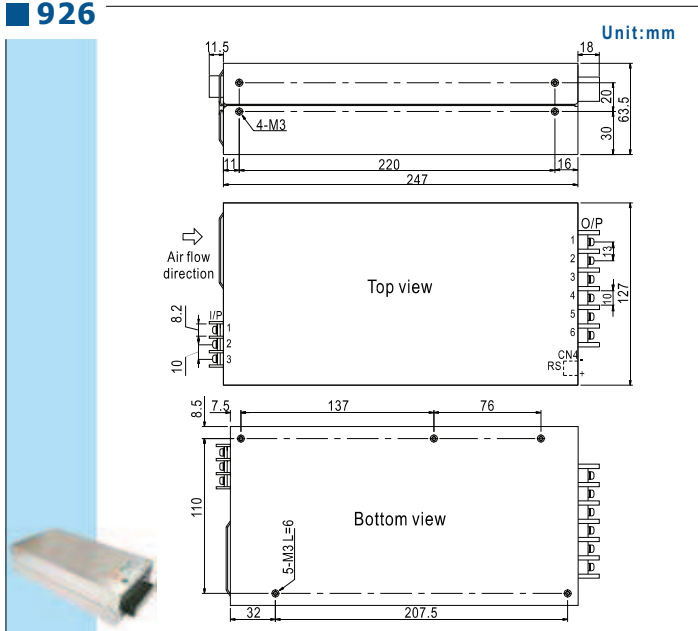

929

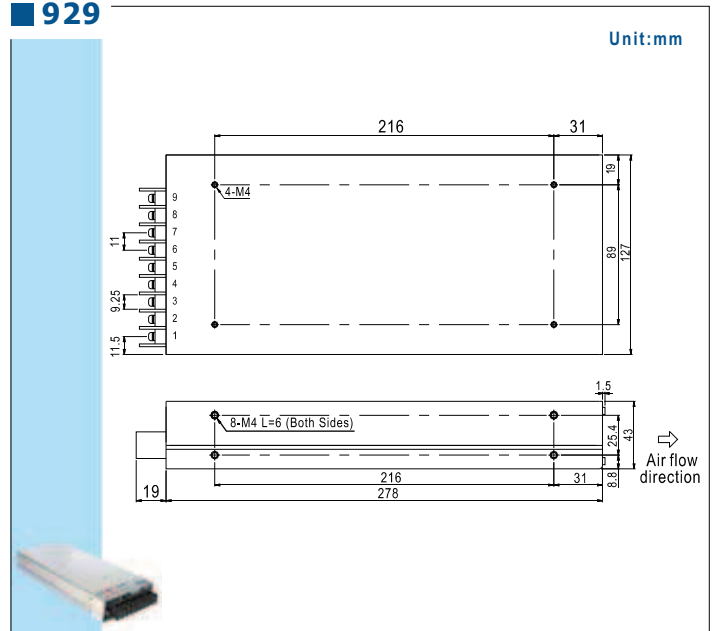

927

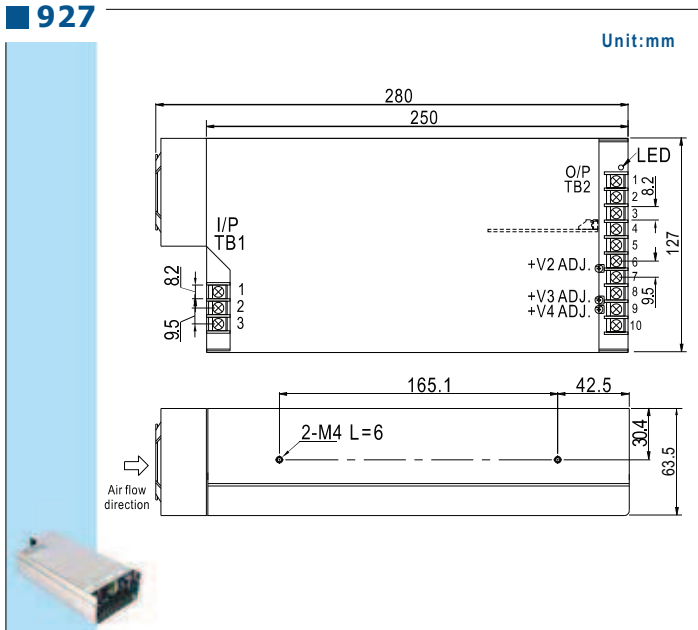

931

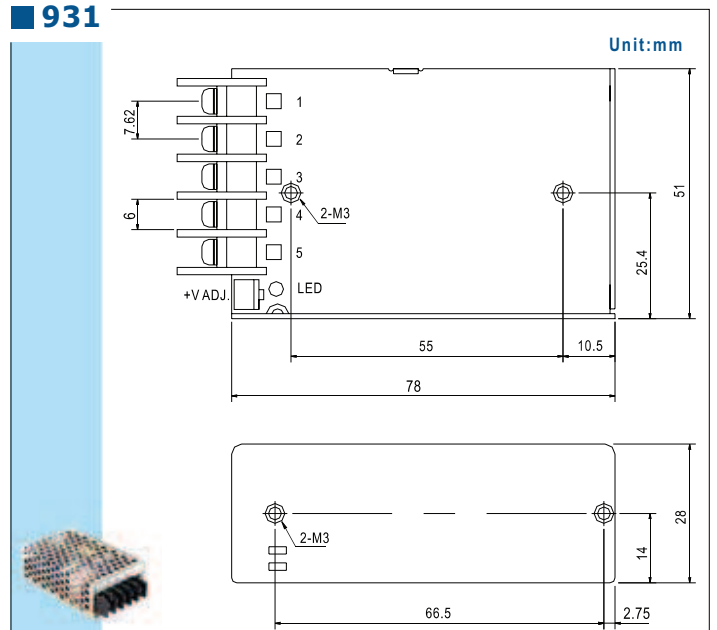

928

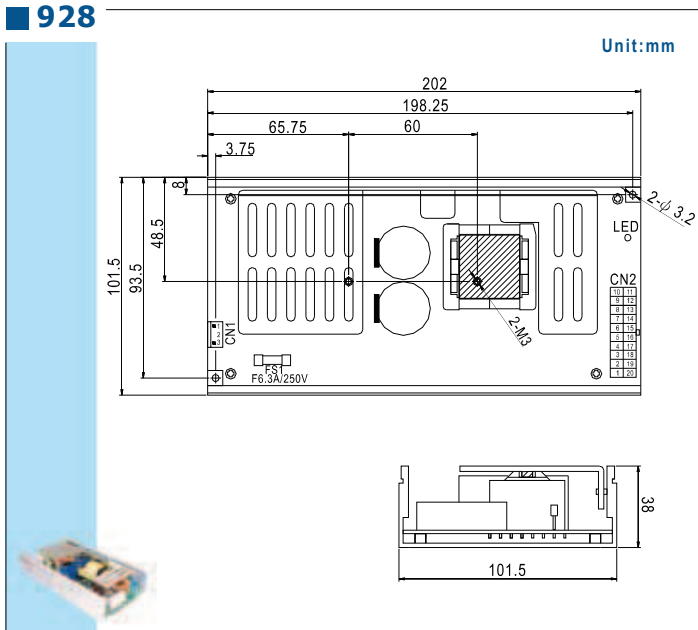

932

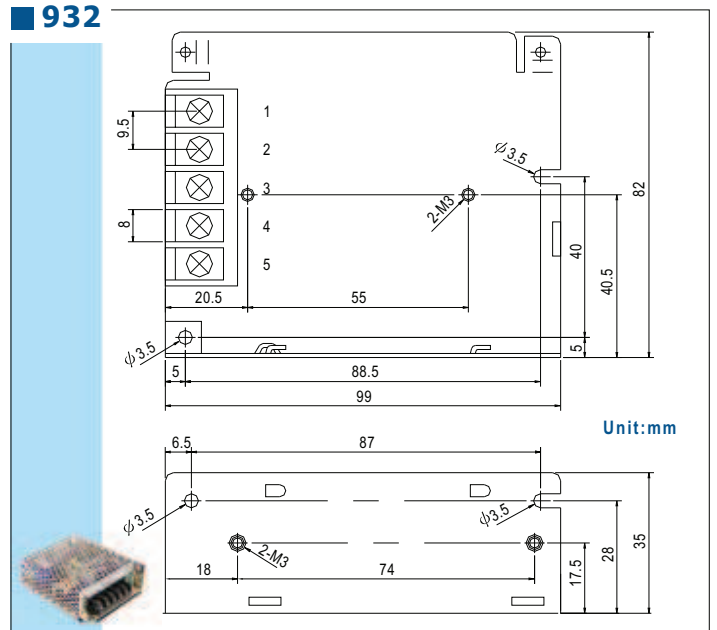

# Case Drawing



## 910

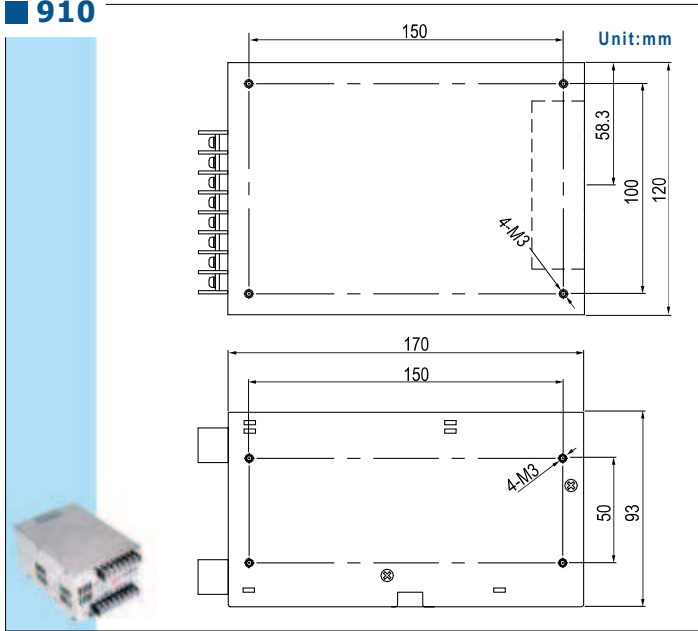

## 916A 916B

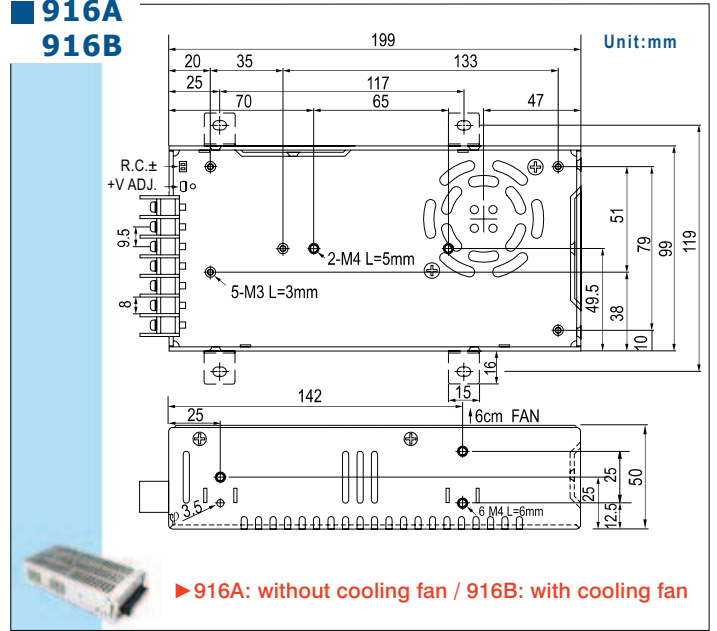

## 912 912B

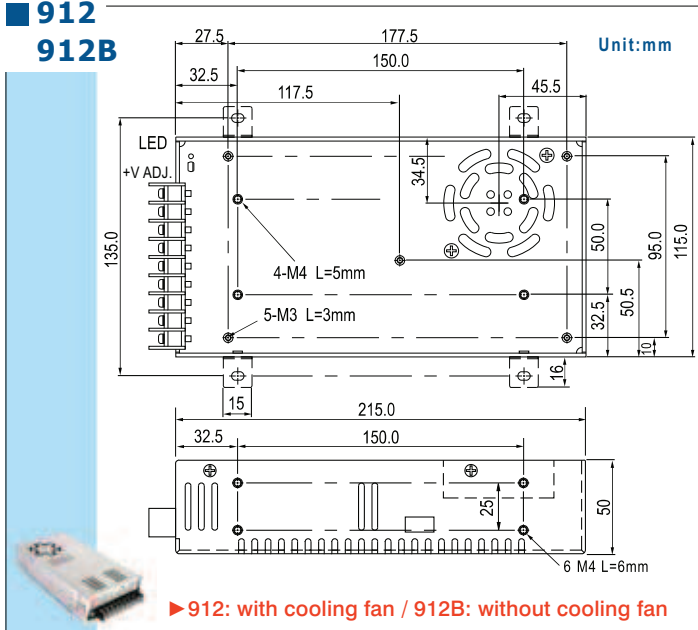

## 919

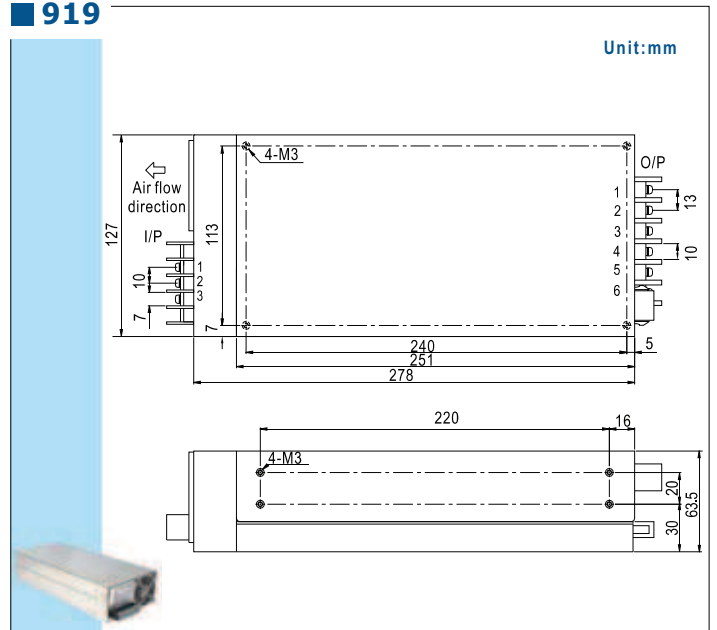

## 915A

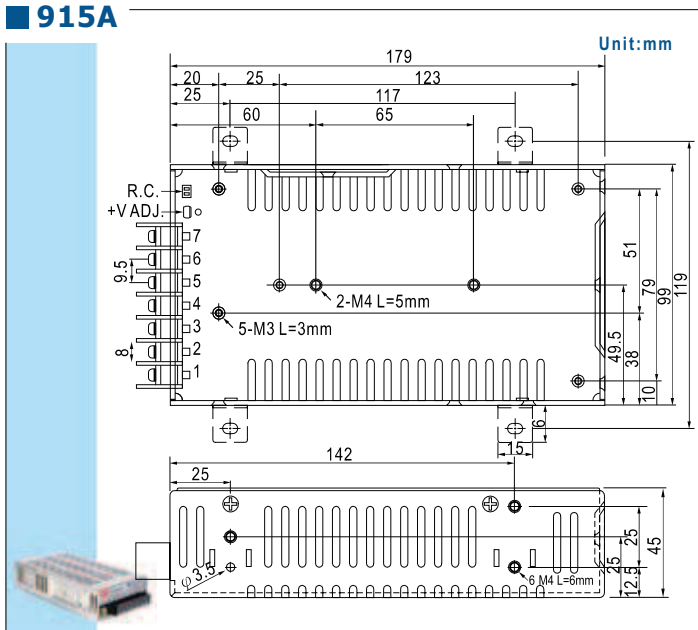

## 920A

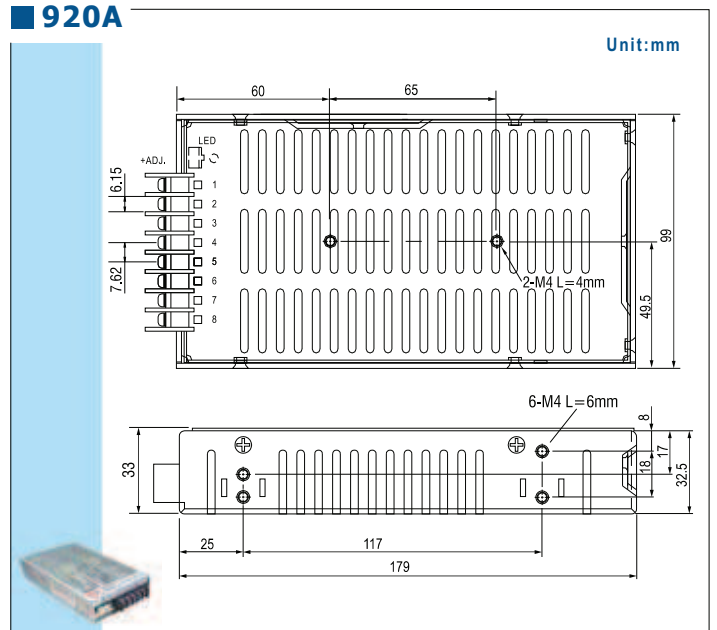

# Case Drawing

**901**

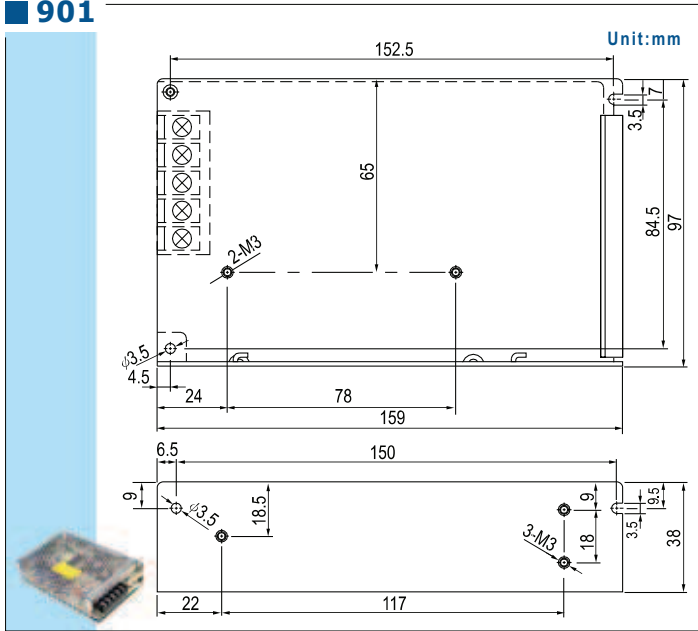

**905**

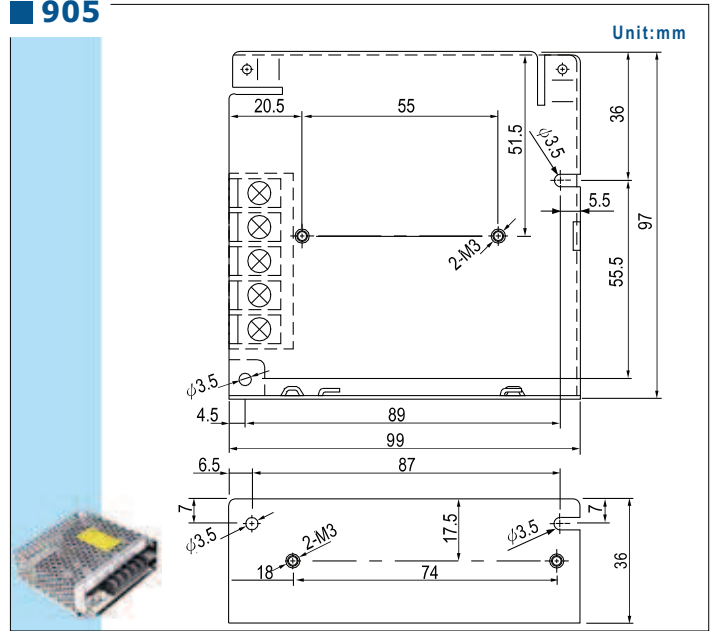

**902**

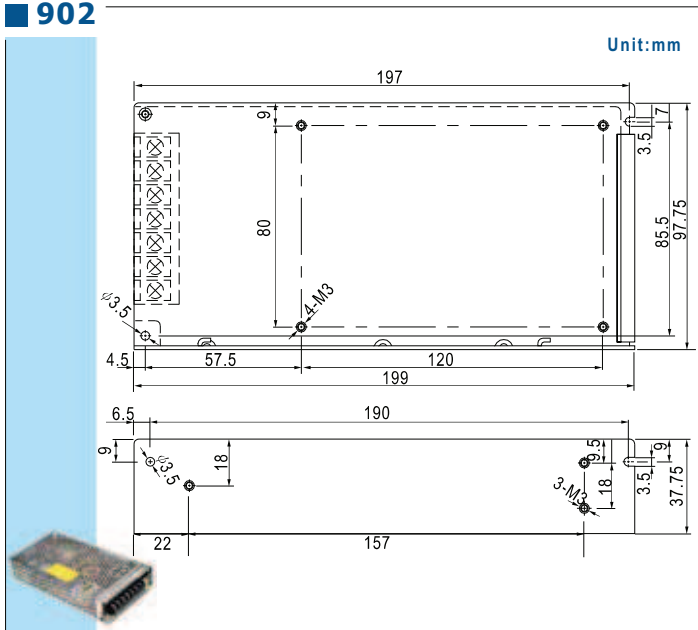

**906**

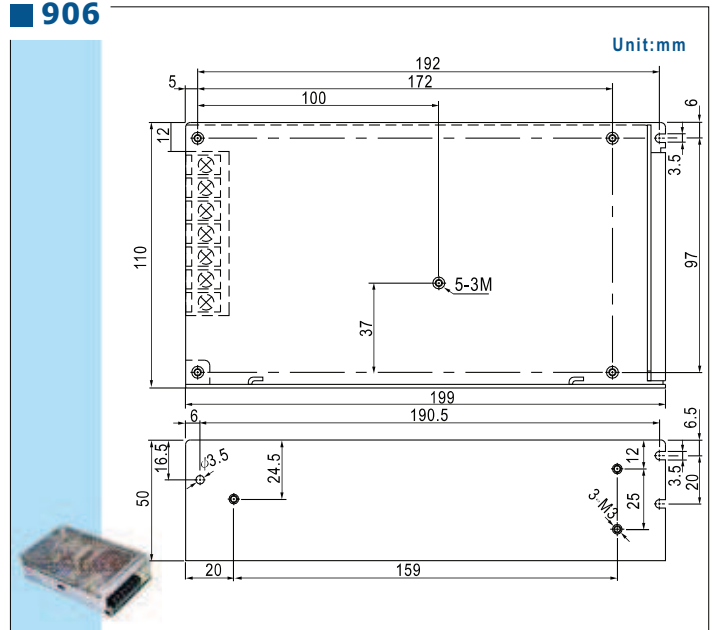

**903**

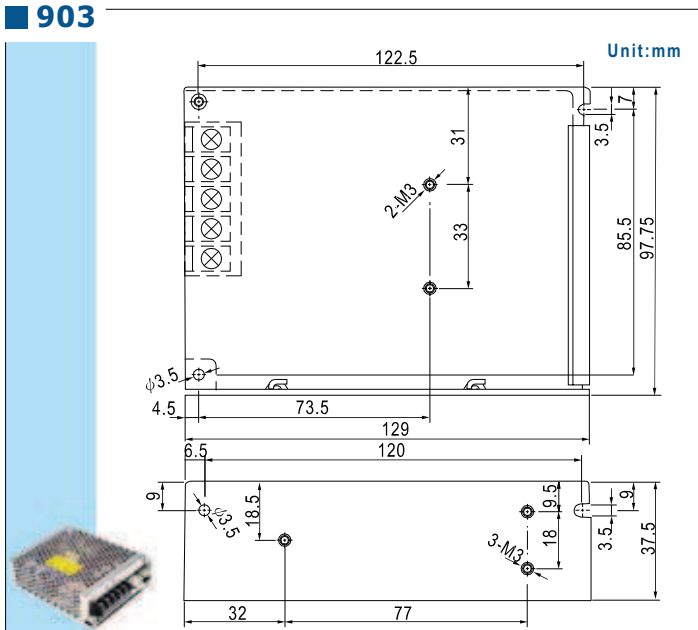

**907**

