

## DT340

**BUS: PCI**

**Type: Low Cost, Counter/Timer, DIO**

# DT340

**Low-Cost, Counter/Timer and Digital I/O Board for the PCI Bus**

### Key Features

- Combines digital I/O and counter/timer functions in one PCI slot.
- New custom counter/timer design for speed and flexibility.
- Four internal interval timers enable periodic interrupt.
- 32 digital I/O channels for high channel-count requirements.
- Eight user accessible counter/timers for event counting, square wave generation, and interval measurement.
- Interrupt on bit change detection for monitoring critical signals.
- Supported by Measure Foundry™, test and measurement application builder software that lets you easily create complex measurement applications.

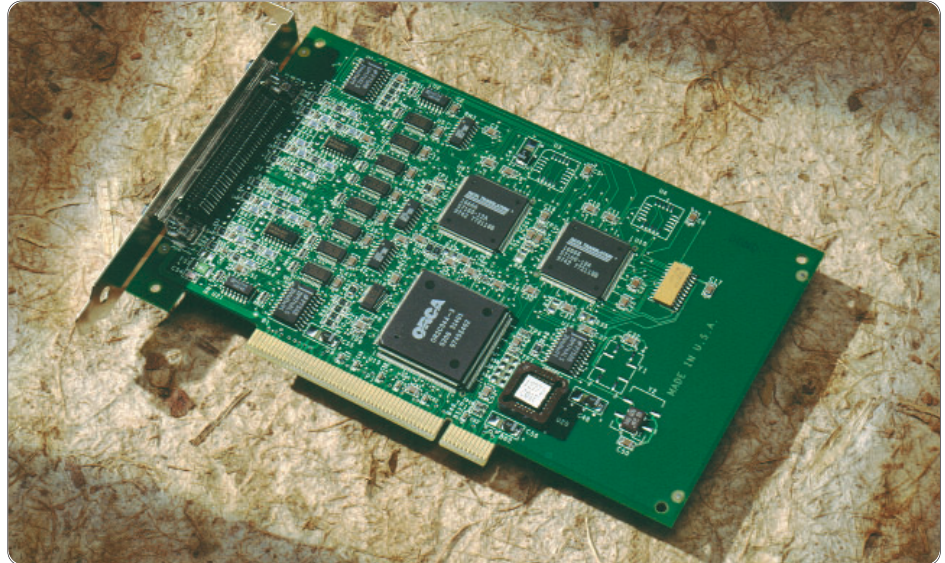

M-5874

The DT340 features eight 16-bit counter/timers, 4 internal interval timers, and 32 digital I/O lines.

### Overview

Ideal for applications that require automated counter/timer and control capabilities, the DT340 is the first board to combine digital I/O and counter/timer functions in a single PCI slot.

### New Counter/Timer Design Enhances Speed and Flexibility

Traditional counter/timer circuits with standard 9513 and 8254 chips are hampered by limitations in speed and flexibility. Data Translation's new custom counter/timer design overcomes these limitations, enabling frequencies up to 20 MHz and providing superior flexibility.

Each of the eight counter/timers accepts a clock input and gate input signal, and outputs a clock output signal. Each counter can use a time base generated from an internal clock or from an external

clock. The internal clock uses a 25 ns time base with output frequencies ranging from 610 Hz to 20 MHz. An external clock is useful when you want to pace counter/timer operations at rates not available with the internal clock or if you want to pace at uneven intervals.

You can also internally route the clock output signal from one counter/timer to the clock input signal of the next counter/timer to internally cascade the counter/timers. In this way, you can create a 32-bit counter/timer. If you want to cascade more than two counter/timers, you can connect the counter/timers externally using the screw terminal panel accessory.

Additionally, you can set each counter to interrupt the CPU when it reaches a count of 0.

### Features Summary

Digital I/O				
Port	Lines per port	Type	Interrupt on Bit Change Detection	SSR Drive
A,B,C	8 bidirectional	Level-sensitive	No	Yes
D	8 bidirectional	Level-sensitive	Yes	Yes
Counter/Timers				
	Channels	Resolution	Maximum Clock Frequency	External Clock
Counter/Timer	8	16-bit	20 MHz	Yes
Interval Timers	4	24-bit	20 MHz	No

You can control the gate of each counter through software or by connecting an external gate signal. The external gate can trigger a one-shot output or can enable event counting, frequency measurement, or rate generation when the gate signal is active.

The DT340 supports pulse output types on the clock output signal with either high-to-low transitions or low-to-high transitions. You can program the duty cycle (or pulse width) of the pulse.

### Four Internal Interval Timers for Periodic Interrupt

The DT340 provides four 24-bit interval timers. Interrupts are individually enabled for each interval timer. You can use these timers to generate a periodic interrupt to the host CPU to time an event, such as reading the digital inputs or updating the digital outputs.

Interval timers use an internal clock input signal; no external connections are used. The frequency of the clock output signal can range from 2.38 Hz to 20 MHz.

### 32 Digital I/O Channels for High Channel-Count Requirements

The DT340 provides 32 digital I/O lines, grouped into four 8-bit ports. You can program each port for either input or output. Digital outputs are capable of driving external solid-state relays (sink 24 mA and source 15 mA).

The DT340 board can generate an interrupt when any of the eight digital I/O lines corresponding to one of the 8-bit digital ports changes state. This feature is useful when you want to monitor critical signals or when you want to signal the host computer to transfer data to or from the board. You can enable the interrupts on a bit-by-bit basis on this port.

### Easy User Connections

All signals are brought out to a dedicated 68-pin connector on the backplate of the DT340 board. The STP68 and STP340 screw terminal panels are available to simplify connections. The EP305 cable connects the DT340 board to the screw terminal panel.

## Software

All boards ship with the Omni CD that includes the following software:

### ■ DT-Open Layers for .NET with DT-Display:

The DT-Open Layers for .NET Class Library is a collection of classes, methods, properties, and events that provides a programming interface for DT-Open Layers-compatible hardware devices. It can be used from any language that conforms to the Common Language Specification (CLS), including Visual Basic.NET, Visual C#, Visual C++.NET with managed extensions, and Visual J#.NET.

— **DT-Display for .NET** is a control for plotting data to a Windows form. It provides a powerful and user-friendly interface for rendering data.

### ■ DT-Open Layers for Win32:

DT-Open Layers for Win32 consists of the DataAcq SDK and DTx-EZ.

— The **DataAcq SDK** consists of the necessary header files, libraries, example programs, and documentation to develop your own DT-Open Layers data acquisition and control applications. It is intended for use with non .NET languages, such as ANSI C, Visual C++ 6.0, and Visual Basic 6.0.

— **DTx-EZ** provides visual programming tools for Microsoft Visual Basic and Visual C++ that enable quick and easy development of test and measurement applications.

Note: If you have an existing application that was written using the DataAcq SDK, we recommend that you migrate your application to use the DT-Open Layers for .NET Class Library. This will guarantee compatibility with future Data Translation hardware and software.

### ■ Drivers:

The 32-bit WDM device drivers make your application cross-platform compatible. These drivers support Data Translation USB and PCI boards using Windows 2000/XP.

You can choose to install demo versions of the following software from the CD:

■ **Measure Foundry** is an open, powerful application builder for test and measurement systems. No programming is required!

■ **quickDAQ** is a high performance, ready-to-run application that lets you acquire, plot, analyze, and save data to disc at 2MHz per channel without writing any code. quickDAQ supports applications from temperature measurement to high-speed testing and analysis.

■ **LV-Link** contains all necessary VIs, examples, and documentation to use Data Translation hardware in LabVIEW 8.0 and greater.

The following software is available as a free download from our web site.

■ **DAQ Adaptor for MATLAB™** to access the visualization and analysis capabilities of MATLAB from The MathWorks™.

### Cross-Series Compatibility Saves Programming Time, Protects Your Investment

Virtually all Data Translation data acquisition boards, including the DT330 Series, are compatible with the DT-Open Layers software standard. This means that if your application was developed with one of Data Translation's software products, you can easily upgrade to a new Data Translation board, now or in the future. Little or no reprogramming is needed. For example, if you are currently using a Data Translation DT2815 data acquisition board, upgrading to a DT330 Series board is simple – just load the new drivers and you're done.

### Technical Support

As you develop your application, technical support is available when you need it. Extensive information is available 24 hours a day on our web site at [www.datatranslation.com](http://www.datatranslation.com), including drivers, example code, bug fixes, pinouts, a searchable KnowledgeBase, and much more.

Support is also available from your point of purchase. Telephone support is free for the first 90 days; you can also request complimentary support via e-mail or fax at any time. Additional support options are available; contact your Data Translation representative for details.

# DT340

BUS: PCI

Type: Low Cost, Counter/Timer, DIO

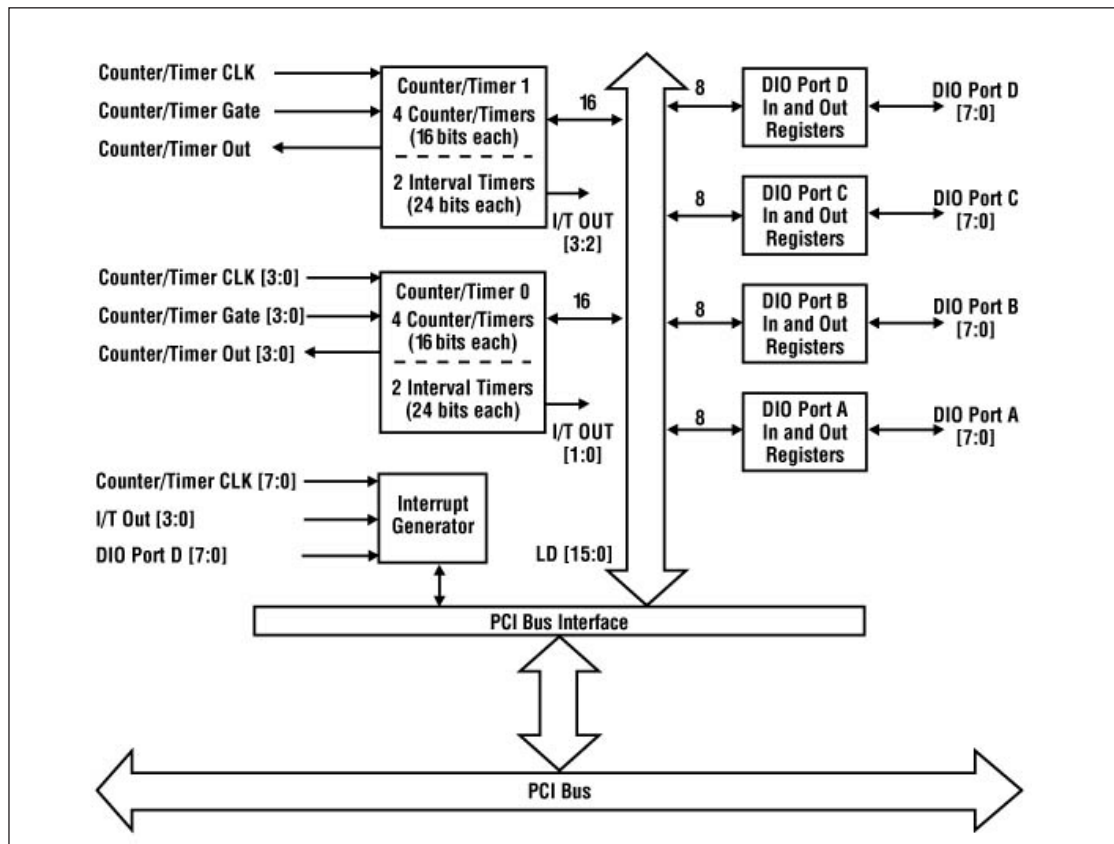

DT340 Block Diagram

## Digital I/O

	Ports A, B, C	Port D
Number of lines	8 bidirectional per port	8 bidirectional
Inputs		
Input type:	Level-sensitive	Level-sensitive
High-level input voltage:	2.0 V minimum	2.0 V minimum
Low-level input voltage:	0.8 V maximum	0.8 V maximum
Minimum pulse width:	Not applicable	66 ns high and low*
Outputs		
Output driver high voltage:	2.4 V minimum (IOH = -15 mA)	2.4 V minimum (IOH = -15 mA)
Output driver low voltage:	0.5 V minimum (IOL = 12 mA)	0.5 V minimum (IOL = 12 mA)

\*The minimum pulse width applies only to interrupt-on-change detection. Pulses less than the minimum may not be detected as a change.

## Accessories

### STP68 Screw Terminal Panel and EP305 Cable

The STP68 screw terminal panel together with the EP305 cable simplifies the connection of digital I/O and counter/timer signals to the DT340 Series boards. Accommodating all user connections on convenient screw clamp connectors, the STP68 mounts on a panel and includes nylon standoffs for table-top applications. The panel measures 3.9375 in. (100 mm) wide by 3.9375 in.

(100 mm) long.

The EP305 is a 68-pin, 79 in., twisted pair, shielded cable that connects the board to the STP68 screw terminal panel.

### DT340 Series Manuals

The DT340 Series getting started and user's manuals are provided in Adobe Acrobat PDF format on the CD-ROM provided with the board; you can view and print them using Acrobat Reader. You can also purchase a hard copy of these manuals, if you wish.

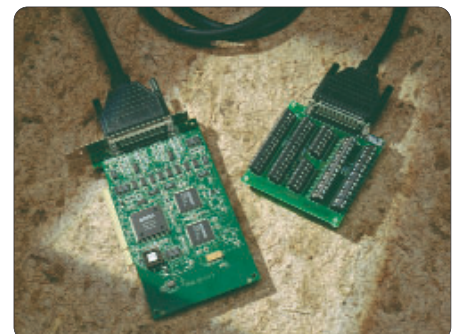

## Counter/Timer

Number of counter/timer channels	8
<b>Clock Inputs</b>	
Threshold voltage:	0.98 V
Input sensitivity:	±200 mV
Input hysteresis:	60 mV
Input current: (Vin = 0)	0
Input current: (Vin = 5 V)	0.5 mA
Minimum pulse width:	25 ns (high); 25 ns (low) sampled by 40 MHz
Maximum frequency:	19.9 MHz typical
<b>Gate Inputs</b>	
High-level input voltage:	2.0 V minimum
Low-level input voltage:	0.8 V maximum
Minimum pulse width:	25 ns (high); 25 ns (low) sampled by 40 MHz
<b>Counter Outputs</b>	
Output driver high voltage:	2.0 V minimum (IOH = -15 mA); 2.4 V minimum (IOH = -3 mA)
Output driver low voltage:	0.5 V maximum (IOL = 24 mA); 0.4 V maximum (IOL = 12 mA)

## Power, Physical, and Environmental Specifications



<b>Power</b>	
+5 V	405 mA + output current nominal
<b>Physical</b>	
Dimensions:	6.875 inches (length) by 4.2 inches (width) (PCI short card)
I/O Connector:	68-pin AMP (#749621-7)
Certification and Compliance	FCC Class A verified; will not compromise FCC compliance of host computer CE
<b>Environmental</b>	
Operating temperature range:	0°C to 70°C
Storage temperature range:	-25°C to 85°C
Relative humidity:	To 95%, noncondensing

## Ordering Summary

All Data Translation hardware products are covered by a 1-year warranty. For pricing information, see a current price list, visit our web site or contact your local reseller.

### DT340

Each DT340 board is shipped with the Data Acquisition Omni CD, which includes DT-Open Layers-compliant drivers for Microsoft Windows 2000/XP, ready-to-run software, and a comprehensive user's manual in PDF format. Manuals are available in hard-copy form for an additional charge.

### DT340 PCI Counter/Timer and Digital I/O Board Accessories

- STP340—Shielded screw terminal panel
- STP68—Low-cost screw terminal panel
- STP68-DIN—STP68 screw terminal panel equipped for DIN-rail mounting
- EP305—68-pin, 79 in., shielded cable for connecting STP68
- DT340 Manual set in hard-copy form

### Software

The following software can be purchased separately:

- Measure Foundry is an open, powerful application builder for test and measurement systems.  
SP1300-CD
- quickDAQ is a high-performance, ready-to-run application that lets you acquire, plot analyze, and save data to disk at up to 2 MHz per channel.  
SP8501-CD
- LV Link to access the power of our boards through LabVIEW.  
SP0811

Data Translation now offers free downloads on the Web for:

- DAQ Adaptor for MATLAB to access the analysis and visualization tools in MATLAB.

© Copyright 2006 Data Translation, Inc. All rights reserved. All trademarks are the property of their respective holders. Prices and specifications subject to change without notice. 03/2007