

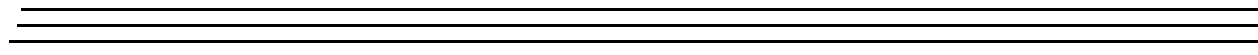

*UM-19133-B*

# *DT3162 Getting Started Manual*

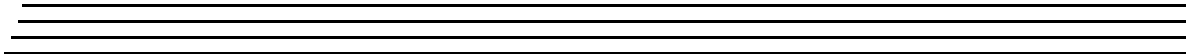
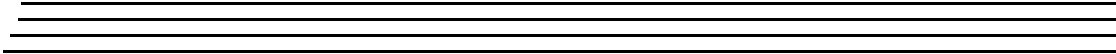

**Second Edition**  
**March, 2002**

**Copyright © 2002 by Data Translation, Inc.**

All rights reserved.

Information furnished by Data Translation, Inc. is believed to be accurate and reliable; however, no responsibility is assumed by Data Translation, Inc. for its use; nor for any infringements of patents or other rights of third parties which may result from its use. No license is granted by implication or otherwise under any patent rights of Data Translation, Inc.

Use, duplication, or disclosure by the United States Government is subject to restrictions as set forth in subparagraph (c)(1)(ii) of the Rights in Technical Data and Computer software clause at 48 C.F.R, 252.227-7013, or in subparagraph (c)(2) of the Commercial computer Software - Registered Rights clause at 48 C.F.R., 52-227-19 as applicable. Data Translation, Inc., 100 Locke Drive, Marlboro, MA 01752

Data Translation<sup>®</sup> and GLOBAL LAB<sup>®</sup> are registered trademarks, Imaging OMNI CD<sup>™</sup>, and DT Vision Foundry<sup>™</sup> are trademarks of Data Translation, Inc.

All other brand and product names are trademarks or registered trademarks of their respective companies.

Data Translation, Inc.  
100 Locke Drive  
Marlboro, MA 01752-1192  
(508) 481-3700  
[www.datatranslation.com](http://www.datatranslation.com)  
Fax: (508) 481-8620  
E-mail: [info@datx.com](mailto:info@datx.com)

---

# Table of Contents

<b>About this Manual</b> .....	<b>v</b>
Intended Audience.....	v
What You Should Learn from this Manual.....	v
Conventions Used in this Manual .....	vi
Related Information .....	vi
Where to Get Help .....	vii
<b>Chapter 1: Overview</b> .....	<b>1</b>
Key Features .....	2
Supported Software .....	3
Accessories .....	4
Getting Started Procedure.....	5
<b>Chapter 2: Preparing to Use the DT3162</b> .....	<b>7</b>
Unpacking .....	9
Checking the System Requirements .....	10
Installing the Software.....	11
Viewing the DT3162 Documentation .....	13
<b>Chapter 3: Installing the Board and Configuring the Device Driver</b> .....	<b>15</b>
Installing the Board .....	17
Setting up the Computer .....	17
Selecting an Expansion Slot.....	18
Inserting the DT3162 Board in the Computer .....	18
Loading and Configuring the Device Driver .....	21

<b>Chapter 4: Connecting Signals</b> .....	<b>23</b>
Connecting Signals to Connector J1. ....	26
Using the EP332 Cable .....	27
Using the Camera Interface Module .....	28
Connecting Signals to Connector J2 .....	35
<b>Chapter 5: Verifying Board Operation</b> .....	<b>37</b>
Overview .....	39
Using DT-Acquire2. ....	40
<b>Chapter 6: Troubleshooting</b> .....	<b>43</b>
General Checklist .....	45
Service and Support. ....	50
Telephone Technical Support. ....	50
E-Mail and Fax Support .....	53
World-Wide Web .....	53
If Your Board Needs Factory Service. ....	54
<b>Index</b> .....	<b>55</b>

# ***About this Manual***

This manual describes how to get started using a DT3162 frame grabber board.

## **Intended Audience**

This document is intended for engineers, scientists, technicians, or others responsible for setting up a DT3162 board to perform machine vision and/or image analysis operations. It is assumed that you have some familiarity with the operating characteristics of your video source. It is also assumed that you are familiar with the Windows 98, Windows Me (Millennium Edition), Windows XP, or Windows 2000 operating system.

## **What You Should Learn from this Manual**

This manual will help you install and set up your board and required software successfully. It is organized as follows:

- [Chapter 1, “Overview,”](#) describes the key features of the DT3162 hardware and software, and provides an overview of the getting started procedure.
- [Chapter 2, “Preparing to Use the DT3162,”](#) describes how to unpack the board and software, check system requirements, install the DT3162 software, and view the DT3162 documentation online.
- [Chapter 3, “Installing the Board and Configuring the Device Driver,”](#) describes how to install the DT3162 board and configure the device driver in Windows 98, Windows Me, Windows XP, or Windows 2000.
- [Chapter 4, “Connecting Signals,”](#) describes how to connect signals to the board.

- [Chapter 5, “Verifying Board Operation,”](#) describes how to verify the board’s operation using DT-Acquire2.
- [Chapter 6, “Troubleshooting,”](#) describes how to resolve issues with the DT3162 board should they occur.
- An index completes this manual.

## Conventions Used in this Manual

The following conventions are used in this manual:

- Notes provide useful information that requires special emphasis, cautions provide information to help you avoid losing data or damaging your equipment, and warnings provide information to help you avoid catastrophic damage to yourself or your equipment.
- Items that you select or type are shown in **bold**.
- Courier font is used to represent source code.

## Related Information

Refer to the following documents for more information on using a DT3162 board:

- The *DT3162 User’s Manual* (UM-19131). This manual (UM3162.PDF), included on the Imaging OMNI CD™, describes the features of the DT3162 board in detail.
- *DT-Active Frame Grabber Controls Getting Started Manual* (UM-19336). This manual (DTFG.PDF) included on the Imaging OMNI CD, describes how to install the DT-Active Frame Grabber Controls in Visual Basic and Visual C++, and describes the properties, methods, and events included in the controls.

- *GLOBAL LAB Image/2 User's Manual* (UM-17790), available from Data Translation, describes how to use GLOBAL LAB® Image/2 and GLOBAL LAB Image/2 Streamline™ to create scientific applications using object-oriented image processing tools.
- *DT Vision Foundry User's Manual* (UM-17755), available from Data Translation, describes how to use DT Vision Foundry™ to create machine vision applications using object-oriented image processing tools.

## **Where to Get Help**

Should you run into problems installing or using a DT3162 board, the Technical Support Department is available to provide technical assistance. Refer to [Chapter 6 starting on page 43](#) for more information. If you are outside the United States or Canada, call your local distributor, whose number is listed in your Data Translation product handbook.





# ***Overview***

Key Features .....	2
Supported Software .....	3
Accessories .....	4
Getting Started Procedure.....	5

## **Key Features**

Key features of the DT3162 board are summarized as follows:

- Operates on the 32-bit, 33 MHz PCI local bus interface;
- Accepts up to three AC-coupled, multiplexed, monochrome, composite input sources;
- Accepts RS-170/RS-343, CCIR, and variable-scan signal types, in software-selectable interlaced or noninterlaced (progressive scan) video formats.
- Accepts separate horizontal and vertical sync inputs or provides separate horizontal and vertical sync outputs for variable-scan devices;
- Provides an internal pixel clock and accepts an external pixel clock with frequencies ranging from 0 to 40 MHz;
- Accepts an external trigger with selectable polarity;
- Provides programmable brightness settings from 0 to 255 and programmable contrast settings from 0 to 100;
- Digitizes 10-bit monochrome video signals into 256 grayscale levels using one of two 1024 x 8-bit, programmable look-up-tables (LUTs);
- Can acquire images up to 2,048 pixels per line by 2,048 lines per frame;
- Supports overlays;
- Provides one programmable TTL-level expose/reset output signal for asynchronous reset cameras;
- Provides one programmable strobe output signal to control lighting for progressive scan cameras;
- Accepts up to four digital input signals which can generate a PCI interrupt on a change of state; and
- Provides up to four digital output signals.

## Supported Software

The following software is available for use with the DT3162 board:

- **DT3162 Device Driver** – This software is provided on the Imaging OMNI CD, which is shipped with the board. You *must* install this device driver to use a DT3162 board with any of the supported software packages or utilities. Refer to [Chapter 2 starting on page 7](#) for information on installing the DT3162 device driver.
- **DT-Active Monochrome Frame Grabber Control**– Use this ActiveX control, provided on the Imaging OMNI CD, if you want to develop your own application software for the DT3162 board using Microsoft Visual Basic or Visual C++ in Windows 98, Windows Me, Windows 2000, or Windows XP. Refer to [Chapter 2 starting on page 7](#) for information on installing the DT3162 software.
- **DT-Acquire2** – This software is provided on the Imaging OMNI CD, which is shipped with the board. This program allows you to verify the operation of your DT3162 board during startup. Refer to [Chapter 5 starting on page 37](#) for information on using DT-Acquire2.
- **GLOBAL LAB Image®/2** – Order this optional software package if you want to develop scientific applications using object-oriented image processing tools.
- **DT Vision Foundry™** – Order this optional software package if you want to develop machine vision applications using object-oriented image processing tools.

Refer to Data Translation's imaging product catalog for information on additional software packages available for the DT3162 board.

## Accessories

The following accessories are available for the DT3162. Unless otherwise noted, you must order these accessories separately:

- **EP332 cable** – A 1-meter integrated cable assembly that provides eight BNC connectors for attaching up to three video inputs, a horizontal and vertical sync input/output, a trigger input, a pixel clock input, and an expose/reset output signal.
- **Camera Interface Module** – A DIN-rail mountable enclosure that provides a Hirose connector for attaching a video input, a horizontal and vertical sync input/output, a TTL pixel clock input, and an expose/reset output signal; two BNC connectors for attaching two additional video inputs; a screw terminal block for attaching external +12 V power; and a screw terminal block for attaching an internal trigger.
- **EP321 cable** – A 2-meter integrated cable assembly that is shipped with the Camera Interface Module module. The EP321 cable attaches connector J1 on the DT3162 board to the VCP (Video Control Port) on the Camera Interface Module.
- **EP261 cable** – A composite video cable assembly that attaches a composite video signal to a BNC connector on the Camera Interface Module or to a BNC connector from the EP332 cable.
- **STP15 screw terminal panel** – A screw terminal panel that accepts digital inputs and provides connections for digital outputs and strobe outputs.
- **EP337 cable** – A 2-meter cable assembly that is shipped with the STP15 screw terminal panel. It attaches the STP15 screw terminal panel to the J2 connector on the DT3162 board.

# Getting Started Procedure

1

The flow diagram shown in [Figure 1](#) illustrates the steps needed to get started using the DT3162 board. This diagram is repeated in each chapter; the shaded area in the diagram shows you where you are in the getting started procedure.

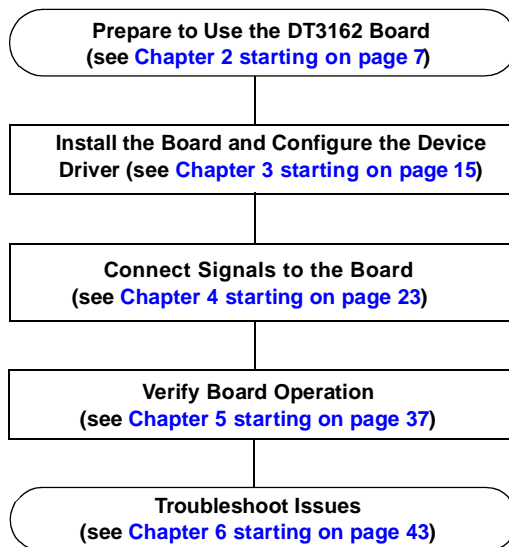

Figure 1: Getting Started Flow Diagram





## ***Preparing to Use the DT3162***

Unpacking .....	9
Checking the System Requirements .....	10
Installing the Software .....	11
Viewing the DT3162 Documentation .....	13

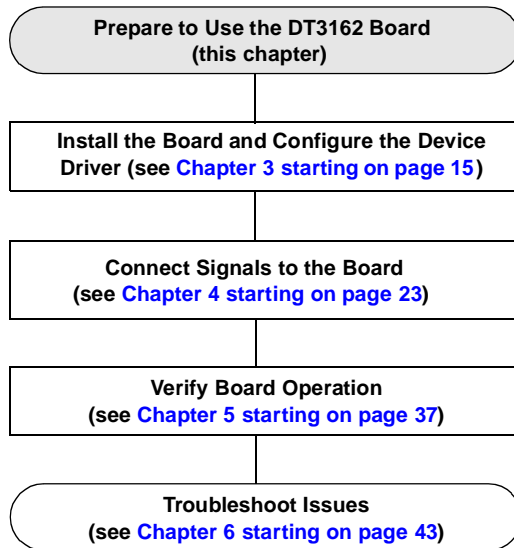

## Unpacking

Open the shipping box and carefully remove the DT3162 frame grabber board.

2

**CAUTION:**

**Keep the DT3162 board in its protective antistatic bag until you are ready to configure and/or install it.**

Verify that the following items are present:

- DT3162 frame grabber board, and
- Imaging OMNI CD.

If an item is missing or damaged, call Data Translation's Customer Service Department at (508) 481-3700 x1394. Customer Service will guide you through the appropriate steps for replacing missing or damaged items. If you are located outside the USA, call your local distributor, listed in your Data Translation Product Handbook.

---

**Note:** We suggest that you save the original packing material in the unlikely event that your board requires servicing in the future.

---

## ***Checking the System Requirements***

For reliable operation, your DT3162 board requires the following minimum system requirements:

- Pentium III processor
- At least one available PCI 32-bit, 33 MHz bus master expansion slot.
- At least 128 MB of RAM.
- A DirectX-compatible graphics adapter set to 24-bit or 32-bit color.
- At least one CD-ROM drive.
- Window 98, Windows Me, Windows 2000, or Windows XP.
- If you are using the DT-Active Monochrome Frame Grabber Control, Microsoft Visual Basic 6.0 or higher or Microsoft Visual C++ 6.0 or higher.

## Installing the Software

To operate properly, the DT3162 board requires the following software components:

- Microsoft DirectX, version 7.0 or greater,
- DT3162 Device Driver, version 1.0 or greater.

You can install these software components from the Imaging OMNI CD. To install the DT3162-related software from the Imaging OMNI CD, perform the following procedure:

---

**Note:** Note that if the DirectX software on your computer is less than version 7.0, you are prompted to install the updated DirectX software, which is provided on the Imaging OMNI CD.

---

1. Insert the Imaging OMNI CD into your CD-ROM drive.  
Note that in most systems, the CD will launch automatically. If your system does not launch the OMNI CD automatically, perform the following steps:
  - a. Click **Start** from the Task Bar, then click **Run**.  
*The Run dialog box appears.*
  - b. Either enter `x:\LAUNCH.EXE` (where *x* is the letter of your CD-ROM drive) or use the Browse button to locate LAUNCH.EXE.
  - c. Click **OK**.  
*The Imaging OMNI CD splash screen appears.*
2. Click **Install Products**.
3. Click **MACH II SERIES**.
4. Click **Install Devices**.

5. Click **DT3162**.  
*If you do not have the proper version of DirectX installed on your system, you are prompted to install updated DirectX software, which is provided on the Imaging OMNI CD; afterwards, you must repeat steps 1 to 5. Otherwise, the InstallShield Wizard appears.*
6. Click **Next**.  
*The license agreement is displayed.*
7. Click **Yes** to accept the license agreement, then click **Finish**.  
*You are prompted to choose your destination location.*
8. Click **Next**.
9. Click **Typical** (which installs the driver, ActiveX control, examples, and manuals), **Compact** (which installs only the driver and ActiveX control), or **Custom** (which allows you to select the components to install).
10. Click **Next**.
11. If you selected Custom, specify the components that you want to install, then click **Next**. Otherwise, continue with the next step.
12. If you are using Windows 98 or Windows Me, select the Restart Later option, then click **Finish**. If you are using Windows 2000 or Windows XP, click **Finish**.
13. Click **Main Menu**, then click **Exit**.

## Viewing the DT3162 Documentation

The DT3162 documentation is installed if you select Typical in the installation procedure, described in the previous section.

You can access these documents through the Data Translation, Inc\DT3162 program folder, or you can view the DT3162 documentation from the Imaging OMNI CD by performing the following steps:

**2**

---

**Note:** This procedure assumes that Adobe Acrobat 4.0 or greater is installed on your system. Acrobat Reader 5.0 is provided on the Imaging OMNI CD. If you install Acrobat Reader 5.0 from this CD, ensure that you open Acrobat Reader and accept the license agreement before performing the following procedure.

---

1. Insert the Imaging OMNI CD into your CD-ROM drive.  
Note that in most systems, the CD will launch automatically. If your system does not launch the OMNI CD automatically, perform the following steps:
  - a. Click **Start** from the Task Bar, then click **Run**.  
*The Run dialog box appears.*
  - b. Either enter `x:\LAUNCH.EXE` (where *x* is the letter of your CD-ROM drive) or use the Browse button to locate LAUNCH.EXE.
  - c. Click **OK**.  
*The Imaging OMNI CD splash screen appears.*
2. Click **Install Products**.
3. Click **MACH II SERIES**.
4. Click **Documentation**.
5. Click **Getting Started Manuals**.

6. Click **DT3162**.
7. View and/or print the PDF manual, then close Adobe Acrobat.
8. Click **Main Menu**.
9. Click **View Documentation**.
10. Click **User's Manuals**.
11. Click **DT3162**.
12. View and/or print the PDF manual, then close Adobe Acrobat.
13. Click **Main Menu**.
14. Click **View Documentation**.
15. Click **DT-Active Frame Grabber Controls (Mach II)**.
16. View and/or print the PDF manual, then close Adobe Acrobat.
17. Click **Main Menu**, then click **Exit**.



# ***Installing the Board and Configuring the Device Driver***

Installing the Board . . . . .	17
Loading and Configuring the Device Driver . . . . .	21

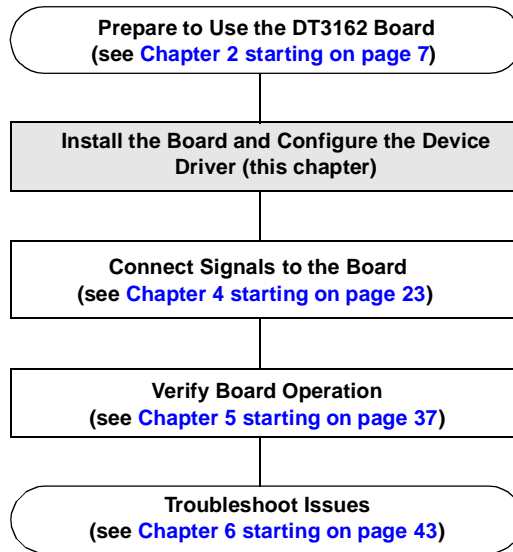

## ***Installing the Board***

To install the board, you need to set up the computer, select an expansion slot, then insert the board into the computer, as described in the following sections.

### **Setting up the Computer**

**CAUTION:**

**To prevent electrostatic damage that can occur when handling electronic equipment, use a ground strap or similar device when performing this installation procedure.**

**3**

Perform the following procedure to set up the computer:

1. Turn off the computer.
2. Turn off all peripherals (printer, modem, monitor, and so on) connected to the computer.
3. Remove the cover from your computer. Refer to your computer's user manual for instructions.

Next, select an expansion slot, as described in the next section.

## Selecting an Expansion Slot

Perform the following procedure to select an expansion slot:

1. Select a 32-bit, 33 MHz PCI master expansion slot. Refer to your computer system's user manual to determine which slots are bus masters.

PCI slots are shorter than ISA or EISA slots and are usually white or ivory. Commonly, three PCI slots (one of which may be a shared ISA/PCI slot) are available. If an ISA board exists in the shared slot, you cannot use the slot for a PCI board; likewise if a PCI board exists in the shared slot, you cannot use the slot for an ISA board.

---

**Note:** In most PCI systems, any PCI slot can be a bus master.

---

2. Remove the cover plate from the selected expansion slot. Retain the screw that held it in place; you will use it later to install the board.

Next, insert the DT3162 board in the expansion slot, as described in the next section.

## Inserting the DT3162 Board in the Computer

To insert the DT3162 board in the computer, perform the following steps:

1. To discharge any static electricity, hold the wrapped board in one hand while placing your other hand firmly on a metal portion of the computer chassis.
2. Carefully remove the antistatic packing material from the board. (We suggest that you save the original packing material in the unlikely event that your board requires servicing in the future.)

3. Hold the board by its edges and do not touch any of the components on the board.
4. Position the board so that the cable connectors are facing the rear of the computer, as shown in [Figure 2](#).

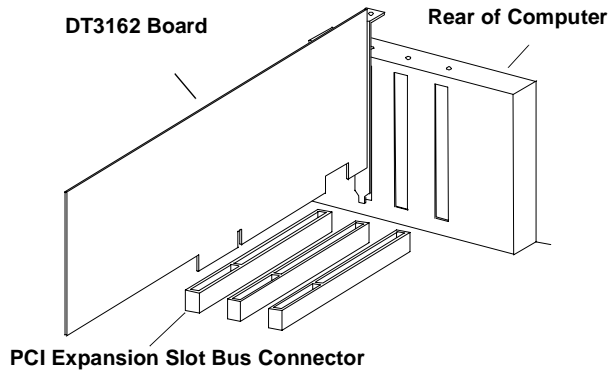

**Figure 2: Inserting the DT3162 Board in the Computer**

5. Carefully lower the board into the PCI expansion slot using the card guide to properly align the board in the slot. When the bottom of the board contacts the bus connector, gently press down on the board until it clicks into place.

**CAUTION:**

**Do not force the board into place. Moving the board from side to side during installation may damage the bus connector. If you encounter resistance when inserting the board, remove the board and try again.**

6. Secure the board in place at the rear panel of the system unit using the screw removed from the slot cover.
7. Replace the cover and turn on the computer.

When you are finished with this procedure, configure the device driver using the instructions in the next section.

## Loading and Configuring the Device Driver

If you are using Windows XP, once you install the board and turn the computer on, the New Hardware Found dialog box appears. Perform the following steps to load the device driver:

1. Select the option to **Install the software automatically (Recommended)**, then click Next.
2. Click **Finish**.

For all other operating systems, the driver is automatically loaded when you install the DT3162 software from the Imaging OMNI CD.

Once the driver has been loaded, configure the DT3162 Device Driver through the DT3162 configuration dialog box. To access the DT3162 configuration dialog box, perform the following steps:

1. Open the Control Panel.
2. Double-click the **DT Imaging Control** icon.
3. Select the DT3162 board to configure.  
*The DT3162 configuration dialog box is displayed.*
4. If you wish, change the alias (or name) of the board.
5. If you want to use the board, ensure that the Disabled box is not checked.
6. Click **Advanced**.
7. By default, the installation program automatically points to the directory in which the configuration and LUT files were installed. If you want to change this directory, either enter or browse to the appropriate folder from which to load or save the configuration and LUT files.

8. By default, the installation program selects the rs-170.ccf configuration file, which is the standard video format in the United States. If this configuration file does not match your video format, select the default configuration file to use, then click **OK**.  
*The default configuration file for Europe is ccir.ccf.*
9. When you are finished, click **OK**.

When you are finished with this procedure, continue by connecting signals to the board. Refer to [Chapter 4 starting on page 23](#).



## ***Connecting Signals***

Connecting Signals to Connector J1. ....	26
Connecting Signals to Connector J2 .....	35

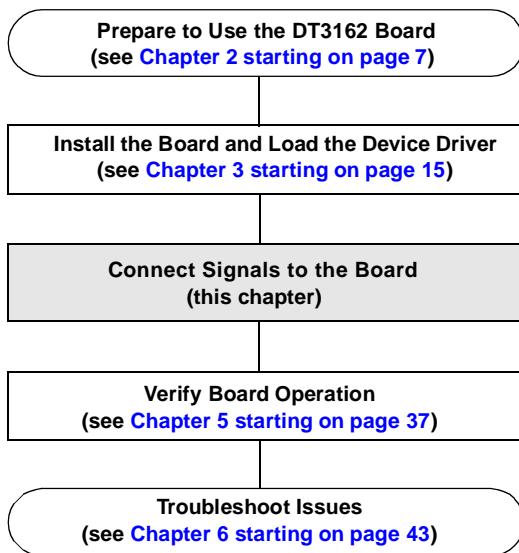

The DT3162 board provides two user connectors: J1 and J2. Connector J1 brings out the video, sync, pixel clock, trigger input, and expose/reset signals. Connector J2 brings out the strobe output and digital I/O signals.

This chapter describes how to connect signals to the board using the J1 and J2 connectors.

**CAUTION:**

**Always turn off the power to both your computer and the input device before making these connections. Damage can result if connections are made with the power on.**

## Connecting Signals to Connector J1

To connect signals to the J1 connector, you can use either of the following solutions:

- **EP332 cable** – Provides eight BNC connectors for attaching up to three video inputs, a horizontal and vertical sync input/output, an external TTL pixel clock input, a trigger input, and an expose/reset output signal.
- **Camera Interface Module (with the EP321)** – A DIN-rail mountable enclosure that provides a Hirose connector for attaching a video input, a horizontal and vertical sync input/output, a TTL pixel clock input, and an expose/reset output signal; two BNC connectors for attaching two additional video inputs; a screw terminal block for attaching external +12 V power; and a screw terminal block for attaching an internal trigger.

Choose the solution that is most convenient for your application. This section describes how to connect signals to the board using either of these solutions.

---

**Note:** If you need to provide a differential pixel clock input, you need to build your own cable to mate with connector J1 on the DT3162 board. Refer to Appendix A and B of the *DT3162 User's Manual* for more information.

---

## Using the EP332 Cable

To connect signals to connector J1 on the DT3162 board using the optional EP332 cable, perform the following steps:

1. After making sure power to the computer is off, push the connector end of the EP332 cable into the J1 socket at the rear of the DT3162 board, as shown in [Figure 3](#), and tighten the screws on the connector.

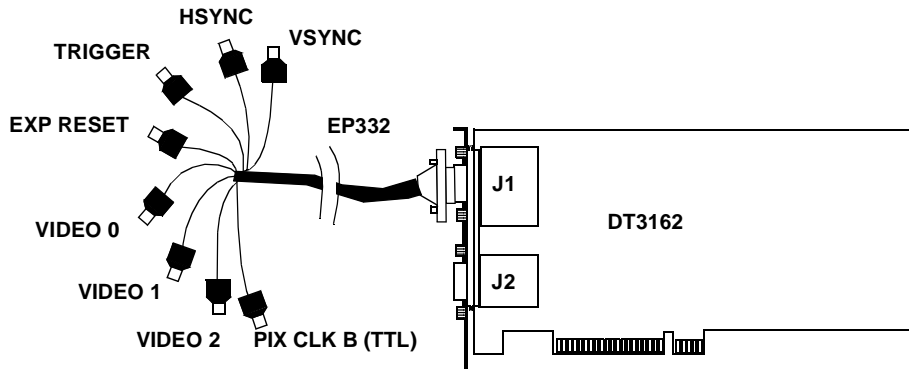

**Figure 3: Connecting the EP332 Cable Assembly to Connector J1**

2. Connect a video source to EP332 connector VIDEO 0, VIDEO 1, or VIDEO 2.

---

**Note:** The EP332 cable terminates in female BNC connectors; this allows you to easily connect to a standard male BNC to BNC cable of the desired length or to the EP261 cable).

---

3. If you are using an external sync input or output, attach the horizontal sync input/output to EP332 connector HSYNC and the vertical sync input/output to EP332 connector VSYNC.
4. If you are using an external trigger source, attach the output of the external trigger source to EP332 connector TRIGGER.
5. If you are using an external TTL-level pixel clock, attach the output of the clock source to EP332 connector PIX CLK B.
6. If you are using an asynchronous reset camera, attach the expose/reset input of your camera to EP332 connector EXP RESET.

Once you have connected all the required signals to the DT3162 board, apply power to the computer, then apply power to your video source.

## Using the Camera Interface Module

This section assumes that you have purchased an optional Camera Interface Module; the EP321 cable is shipped with the Camera Interface Module.

To connect signals to connector J1 on the DT3162 board using the Camera Interface Module, perform the following steps:

1. After making sure power to the computer is off, push one end of the EP321 cable into the J1 socket at the rear of the DT3162 board, push the other end of the EP321 cable into the VCP connector of the Camera Interface Module, and tighten the screws on both connectors. [Figure 4](#) illustrates this step.

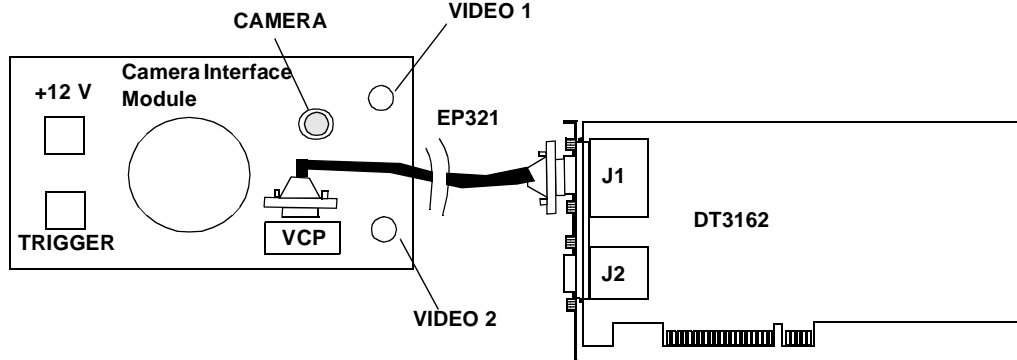

**Figure 4: Connecting the Camera Interface Module to Connector J1**

4

2. Connect a video source to either the CAMERA Hirose connector (in software this connector is referred to as VIDEO 0), the VIDEO 1 BNC connector, or the VIDEO 2 BNC connector on the Camera Interface Module.

The cable that connects to the CAMERA connector is specific to the camera used and should be provided by the camera manufacturer. The CAMERA connector has 12 pins which correspond to many of the signals brought out from the J1 connector on the DT3162 board. The configuration of the jumpers, described in step 6, determines which signals are available to the camera.

The EP261 cable, available from Data Translation, is available for connecting a composite video signal to a BNC connector on the Camera Interface Module.

3. If you are using an external trigger source, attach the output of the external trigger source to the TRIGGER screw terminals on the Camera Interface Module.

4. If you want to provide +12 V to the video source connected to the CAMERA connector, attach a +12 VDC power supply to the +12 V screw terminals on the Camera Interface Module.
5. Using a flat screw driver, lift the round metal cover on the Camera Interface Module to expose the camera jumpers, as shown in [Figure 5](#).

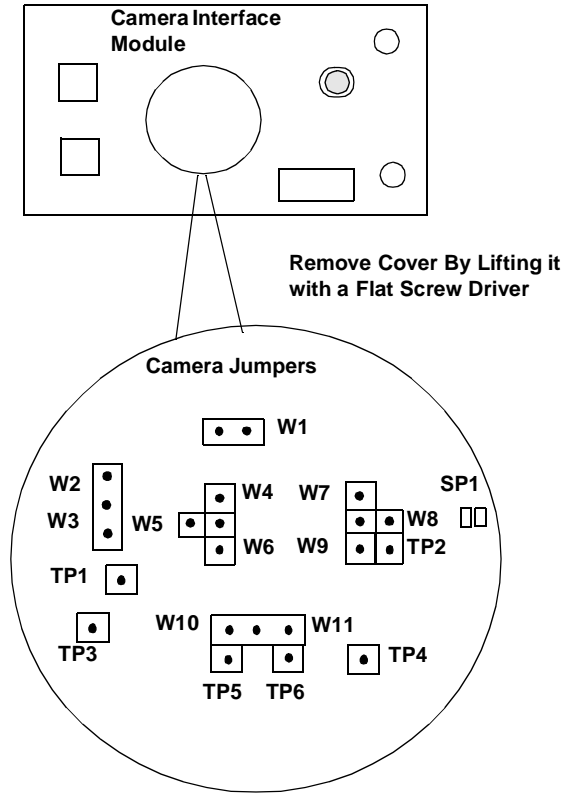

Note: By default, jumpers W1, W3, W4, and W11 are installed.

Figure 5: Exposing the Camera Jumpers on the Camera Interface Module

6. Install the camera jumpers according to your camera configuration. [Table 4](#) lists the pin assignments of the CAMERA connector on the Camera Interface Module; [Table 5](#) summarizes the function of each camera jumper.

**WARNING!**

**Refer to your camera documentation before configuring pins 6 through 11 of the CAMERA connector on the Camera Interface Module. Misconfiguration of pin 11 may cause damage to the DT3162, Camera Interface Module, and/or your camera.**

**4**

**Table 4: CAMERA Connector Pin Assignments**

Pin	Description	Pin	Description
1	Digital Ground	2	+12 V <sup>a</sup>
3	Video 0 Return	4	Video 0
5	Digital Ground	6	HSync or Expose/ Reset <sup>b</sup>
7	VSync or Expose/Reset <sup>c</sup>	8	Digital Ground
9	HSync, Pixel Clock, or Expose/Reset <sup>d</sup>	10	Digital Ground or Not Connected <sup>e</sup>
11	Pixel Clock, Expose/Reset, or +12 V <sup>a,f</sup>	12	Digital Ground

- a. This is the input from the 12 VDC terminal block.
- b. To access the HSync signal on pin 6, install jumper W3 (by default, this jumper is installed); or to access the Expose/Reset signal on pin 6, install jumper W2.
- c. To access the VSync signal on pin 7, install jumper W11 (by default, this jumper is installed); or to access the Expose/Reset signal on pin 7, install jumper W10.
- d. To access the HSync signal on pin 9, install jumper W5; to access the Pixel Clock signal on pin 9, install jumper W6; or to access the Expose/Reset signal on pin 9, install jumper W4 (by default, this jumper is installed).
- e. To access the Digital Ground signal on pin 10, install jumper W1 (by default, this jumper is installed). If jumper W1 is not installed, this pin is not connected to any signal.

- f. To access the Pixel Clock signal on pin 11, install jumper W9; to access the Expose/Reset signal on pin 11, install jumper W7; or to access the +12 V signal on pin 11, install jumper W8 and place a short across Solder Pad 1 (SP1).

**Table 5: Camera Interface Module Jumpers**

Jumpers <sup>a</sup>	Pin Affected	Signal Description
W1	10	If this jumper is installed (the default configuration), the Digital Ground signal is accessible on pin 10 of the CAMERA connector. If this jumper is not installed, pin 10 has no signal connected to it.
W2	6	If this jumper is installed, the Expose/Reset signal is accessible on pin 6 of the CAMERA connector.
W3	6	If this jumper is installed (the default configuration), the HSync signal is accessible on pin 6 of the CAMERA connector.
W4	9	If this jumper is installed (the default configuration), the Expose/Reset signal is accessible on pin 9 of the CAMERA connector.
W5	9	If this jumper is installed, the HSync signal is accessible on pin 9 of the CAMERA connector.
W6	9	If this jumper is installed, the Pixel Clock signal is accessible on pin 9 of the CAMERA connector.
W7 <sup>b</sup>	11	If this jumper is installed, the Expose/Reset signal is accessible on pin 11 of the CAMERA connector.
W8 and Solder Pad 1 <sup>b,c</sup>	11	If this jumper is installed, the +12 V signal is accessible on pin 11 of the CAMERA connector.

**Table 5: Camera Interface Module Jumpers (cont.)**

Jumpers <sup>a</sup>	Pin Affected	Signal Description
W9 <sup>b</sup>	11	If this jumper is installed, the Pixel Clock signal is accessible on pin 11 of the CAMERA connector.
W10	7	If this jumper is installed, the Expose/Reset signal is accessible on pin 7 of the CAMERA connector.
W11	7	If this jumper is installed, the VSync signal is accessible on pin 7 of the CAMERA connector. By default, this jumper is installed.

- a. If a specified jumper is installed, the corresponding signal is available to the camera on the pin specified. If a specified jumper is not installed, the corresponding signal is not available to the camera on the pin specified. Only one jumper corresponding to a pin can be installed at a time.
- b. Misconfiguration of this jumper can cause damage to the DT3162, Camera Interface Module, or your camera.
- c. If your camera requires 12 V on pin 11, you need to install jumper W8 and place a short across Solder Pad 1 (SP1).

7. If you wish, use test points TP1 to TP6 to debug your camera set up. [Table 6](#) describes the function of test points TP1 to TP6.

**Table 6: Test Point Descriptions**

Test Points	Description	Test Points	Description
TP1	Digital Ground	TP4	Vertical Sync
TP2	Pixel Clock 1 <sup>a</sup>	TP5	Expose/Reset
TP3	Horizontal Sync	TP6	Trigger

- a. Pixel Clock 1 is a TTL-level signal from the camera that is converted to an LVDS differential signal (PIX CLK1+ and PIX CLK1-) for the DT3162 board.

8. Once you have connected all the required signals to the DT3162 board, apply power to the computer, then apply power to your video source.

---

**Note:** When +12 V power is applied to the Camera Interface Module, the LED next to the +12 V connector lights.

When the Camera Interface Module detects the rising edge of an expose/reset pulse that is output from the DT3162 board, the LED next to the TRIGGER connector lights momentarily.

---

## Connecting Signals to Connector J2

This section assumes that you have purchased an optional STP15 screw terminal panel; the EP337 cable is shipped with the STP15.

To connect signals to connector J2 on the DT3162 board, perform the following steps:

1. Make sure power to the computer is off.
2. Push one end of the EP337 cable into the J2 socket at the rear of the DT3162 board, then push the other end of the EP337 cable into the STP15 screw terminal panel. [Figure 6](#) illustrates this step.

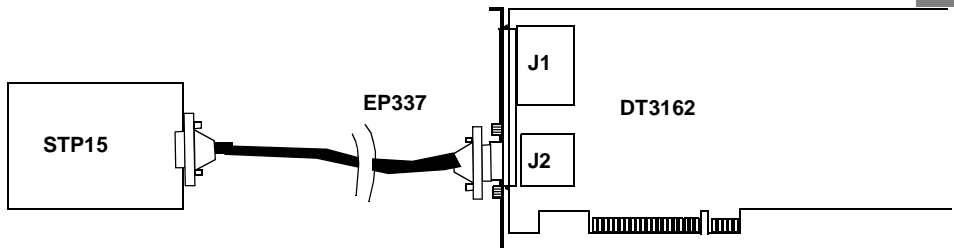

**Figure 6: Connecting the STP15 to the DT3162 Board**

3. Connect digital input, digital output, and/or strobe output signals to the screw terminals of the STP15. [Figure 7](#) shows the layout of the STP15 and the signal descriptions for each screw terminal.

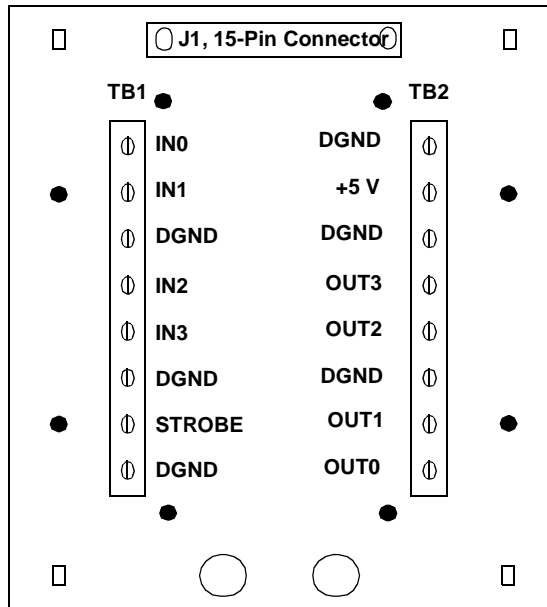

**Figure 7: Layout of the STP15 Screw Terminal Panel**

---

**Notes:** In [Figure 7](#), IN refers to digital input signals, OUT refers to digital output signals, STROBE refers to strobe output signal, DGND refers to digital ground signals, and +5 V refers to a +5 V (100 mA) output signal from the DT3162 board.

The dark filled circles in [Figure 7](#) represent holes that you can use to mount the STP15 on a DIN rail. To mount the STP15 on a DIN rail, you need two DIN rail mount adapters (Phoenix Contact part number 1201578 or Data Translation part number 18083), and four thread form screws (Bossard part number BN2724M3x8 or Data Translation part number 18193).

---



## ***Verifying Board Operation***

Overview .....	39
Using DT-Acquire2.....	40

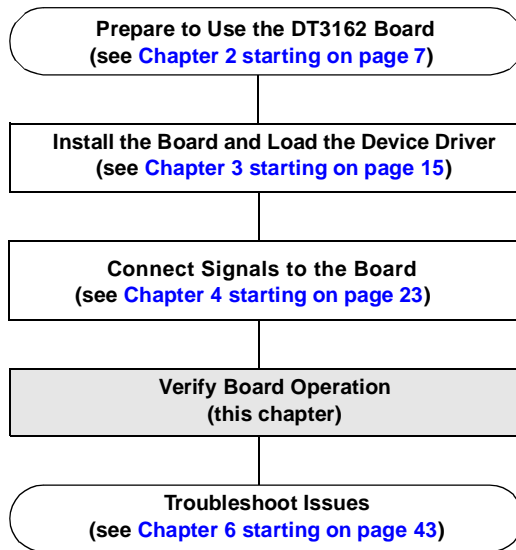

## Overview

The DT-Acquire2 example program provides a quick way to verify that your board is properly installed, that the camera or cameras are properly connected, and that you can acquire images.

DT-Acquire2 allows you to

- Acquire either a single image or continuous images,
- Open a previously saved BMP image,
- Save an acquired image in BMP format,
- Load a configuration file,
- Save a configuration file, and
- Perform a digital I/O operation.

DT-Acquire2 is automatically installed when you install the DT3162 software providing that you select either the Typical installation option or the Custom installation option with Example Applications checked (see [page 11](#) for more information).

## Using DT-Acquire2

To start DT-Acquire2, click the **DT-Acquire2** icon in the Data Translation, Inc\DT3162\ program group. The main menu is displayed.

---

**Note:** For specific information about the components of DT-Acquire2, click **Help** from the DT-Acquire2 main menu, then click **DT-Acquire2 Help Topics**.

---

To use DT-Acquire2, perform the following steps:

1. Connect a video input signal to video source 0, 1, or 2; connect control signals and strobe, expose/reset, and digital I/O signals, as needed. Refer to [Chapter 4 starting on page 23](#) for more information.
2. From the DT-Acquire2 main menu, click **File**, then **Select Device**.
3. Select the alias that you gave to the DT3162 board when you configured the device driver, then click **OK**.
4. Click **Setup**, then click **Timeout**, and enter a value to indicate when the acquisition should timeout if a valid video signal is not present.
5. To use an existing configuration, click **File**, click **Load/Save Configuration File**, highlight the file to use, click **Load**, then go to step 12. Otherwise, continue with step 6.
6. Click **Setup**, then click **Configure**.
7. Use the Input tab to configure the sync input signals, input video source, trigger, and pixel clock source, then click **OK**.

8. Use the Output tab to configure the sync output (if used) or to set up the strobe and expose output pulses, if desired. Note that if you enable either strobe or expose, the pulses are output when you start the acquisition. When you are finished with this tab, click **OK**.
9. Use the Capture tab to configure the video signal, region of interest, and the brightness and contrast settings. You can see the effect of these changes by selecting either **Start Continuous Acquire** or **Single Frame Acquire**. To stop a continuous acquire operation, select **Stop Continuous Acquire**. When you are finished with this tab, click **OK**.
10. Use the LUT tab to select the look-up table to use, then click **OK**. By default, LUT 0 uses the identity pattern; LUT 1 uses the inverse pattern.  
*The display window shows the results of applying the values in the LUT to the incoming video.*
11. To save this configuration, click **File** from the DT-Acquire2 main menu, click **Load/Save Configuration File**, click **Save**, enter the name of the configuration file, the name of the creator of the file (optional), and a short description of the file (optional), then click **OK**.
12. From the DT-Acquire2 main menu, click **Run**, then click either **Start Continuous Acquire** or **Single Frame Acquire**.  
*Images are acquired and displayed on the screen.*
13. To save an image if desired, click **File** from the DT-Acquire2 main menu, then click **Save Image File**.
14. To perform a digital I/O operation, click **Setup**, then click **Digital I/O**. To read the digital input line, click **Read**. To perform a digital output operation, set the digital output values appropriately; the selected values are written immediately to the digital output lines. Click **OK** when you are finished with this menu option.
15. When you are finished with this program, click **File** from the DT-Acquire2 main menu, then click **Close Device** and close the application.





## ***Troubleshooting***

General Checklist .....	45
Service and Support .....	50
If Your Board Needs Factory Service .....	54

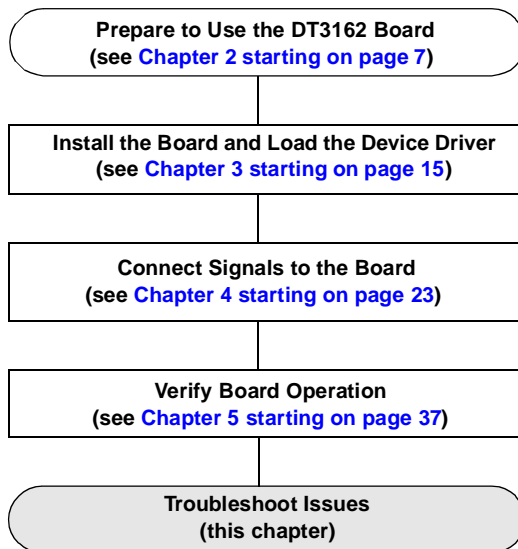

## General Checklist

Should you experience problems using the DT3162 board, follow these steps:

1. Read all the documentation provided for your product. Make sure that you have added any “Read This First” information to your manual and that you have used this information.
2. Check the Imaging OMNI CD for any README files and ensure that you have used the latest installation and configuration information available.
3. Check that your system meets the requirements stated on [page 10](#).
4. Check that you have installed the software properly using instructions starting on [page 11](#).
5. Check that you have installed your hardware properly using the instructions starting on [page 17](#).
6. Check that you have configured the device driver properly using the instructions on [page 21](#).
7. Search the DT Knowledgebase in the Support section of the Data Translation web site (at [www.datatranslation.com](http://www.datatranslation.com)) for an answer to your problem.

If you still experience problems, try using the information in [Table 7](#) to isolate and solve the problem. If you cannot identify the problem, refer to [page 50](#).

**Table 7: Troubleshooting Problems**

Symptom	Possible Cause	Possible Solution
Board does not respond.	The board is incorrectly aligned in a PCI expansion slot.	Check that the slot in which your DT3162 board is located is a PCI slot and that the board is correctly seated in the slot; see the instructions starting on <a href="#">page 17</a> .
	The interrupt level is unacceptable.	<p>An interrupt conflict exists in your system. The most common interrupt conflict occurs with a PCI device and a device that is plugged into the ISA bus. To resolve this problem, change the interrupt setting (usually by changing a jumper) on the ISA device.</p> <p>An interrupt conflict can also occur if a PCI device was not designed to share interrupts. To resolve this problem, select a different interrupt for each PCI slot in the PCI BIOS. To do this, enter the system BIOS program; this is usually done by pressing the DEL key when rebooting your system. Once in the system BIOS, enter the PCI/PnP BIOS setup, and select a unique interrupt for each PCI slot. The PCI BIOS assigns the interrupt; the device on the PCI bus does not have control over the interrupt assignment.</p> <p>Some network devices do not share interrupts. If you still have an interrupt conflict, try removing the network device, installing the DT3162 board and rebooting the system, then reinserting the network device.</p>
	The board is damaged.	Contact Data Translation for technical support; refer to <a href="#">page 50</a> .
	The recalibrate operation failed.	Contact Data Translation for technical support; refer to <a href="#">page 50</a> .

**Table 7: Troubleshooting Problems (cont.)**

Symptom	Possible Cause	Possible Solution
Intermittent operation.	Loose connections or vibrations exist.	Check your wiring and tighten any loose connections or cushion vibration sources; see the instructions in <a href="#">Chapter 4 starting on page 23</a> .
	Electrical noise exists.	Check your connections; see the instructions in <a href="#">Chapter 4 starting on page 23</a> .
	The board is overheating.	Check environmental and ambient temperature; consult the board's specifications in Appendix A of the <i>DT3162 User's Manual</i> and the documentation provided by your computer manufacturer for more information.
Data appears to be invalid.	Wiring is not connected properly.	Check your wiring and fix any open connections; see the instructions in <a href="#">Chapter 4 starting on page 23</a> .
Computer does not boot.	Board is not seated properly.	Check that the slot in which your DT3162 board is located is a PCI slot, that the board is correctly seated in the slot, and that the board is secured in the slot with a screw; see the instructions in the <i>DT3162 Getting Started Manual</i> .
	The power supply of the computer is too small to handle all the system resources.	Check the power requirements of your system resources and, if needed, get a larger power supply; consult the board's specifications in Appendix A of the <i>DT3162 User's Manual</i> .

**Table 7: Troubleshooting Problems (cont.)**

Symptom	Possible Cause	Possible Solution
System locked up.	Board is not seated properly.	Check that the slot in which your DT3162 board is located is a PCI slot, that the board is correctly seated in the slot, and that the board is secured in the slot with a screw; see the instructions starting on <a href="#">page 17</a> .
	Interrupt level is unacceptable.	<p>An interrupt conflict exists in your system. The most common interrupt conflict occurs with a PCI device and a device that is plugged into the ISA bus. To resolve this problem, change the interrupt setting (usually by changing a jumper) on the ISA device.</p> <p>An interrupt conflict can also occur if a PCI device was not designed to share interrupts. To resolve this problem, select a different interrupt for each PCI slot in the PCI BIOS. To do this, enter the system BIOS program; this is usually done by pressing the DEL key when rebooting your system. Once in the system BIOS, enter the PCI/PnP BIOS setup, and select a unique interrupt for each PCI slot. The PCI BIOS assigns the interrupt; the device on the PCI bus does not have control over the interrupt assignment.</p> <p>Some network devices do not share interrupts. If you still have an interrupt conflict, try removing the network device, installing the DT3162 board and rebooting the system, then reinserting the network device.</p>

**Table 7: Troubleshooting Problems (cont.)**

Symptom	Possible Cause	Possible Solution
Images are scrambled.	The capture properties are not set appropriately.	Refer to the documentation for your camera or image device and set the capture properties to match the requirements of your device. Refer to the <i>DT3162 User's Manual (UM3162.PDF)</i> and to the FGXMONO.HLP file on the Imaging OMNI CD for more information.
Acquisition operation timed out.	The capture properties are not set appropriately.	Refer to the documentation for your camera or image device and set the capture properties to match the requirements of your device. Refer to the <i>DT3162 User's Manual (UM3162.PDF)</i> and to the FGXMONO.HLP file on the Imaging OMNI CD for more information.
	Wiring is not connected properly.	Check your wiring and fix any open connections; see the instructions in <a href="#">Chapter 4 starting on page 23</a> .

## ***Service and Support***

If you have difficulty using the DT3162 board, Data Translation's Technical Support Department is available to provide prompt technical assistance. Support upgrades, technical information, and software are also available.

All customers can always obtain the support needed. The first 90 days are complimentary, as part of the product's original warranty, to help you get your system running. Customers who call outside of this time frame can either purchase a support contract or pay a nominal fee (charged on a per-incident basis).

For "priority support," purchase a support contract. Support contracts guarantee prompt response and are very affordable; contact your local sales office for details.

Refer to the Data Translation Support Policy located at the end of this manual for a list of services included and excluded in our standard support offering.

### **Telephone Technical Support**

Telephone support is normally reserved for original warranty and support-contract customers. Support requests from non-contract or out-of-warranty customers are processed after requests from original warranty and support-contract customers.

For the most efficient service, complete the form on [page 52](#) and be at your computer when you call for technical support. This information helps to identify specific system and configuration-related problems and to replicate the problem in house, if necessary.

You can reach the Technical Support Department by calling (508) 481-3700 x1401.

If you are located outside the USA, call your local distributor. The name and telephone number of your nearest distributor are provided in your Data Translation catalog.

If you are leaving a message to request a support call, include the following information:

- Your name (include proper spelling),
- Your company or organization (include proper spelling),
- A phone number,
- An e-mail address where you can be reached,
- The hardware/software product you need help on,
- A summary of the issue or question you have,
- Your contract number, if applicable, and
- Your product serial number or purchase date.

Omitting any of the above information may delay our ability to resolve your issue.

### Information Required for Technical Support

Name: \_\_\_\_\_ Phone \_\_\_\_\_

Contract Number: \_\_\_\_\_

Address: \_\_\_\_\_

\_\_\_\_\_

Data Translation hardware product(s): \_\_\_\_\_

serial number: \_\_\_\_\_

configuration: \_\_\_\_\_

Data Translation device driver - SPO number: \_\_\_\_\_

version: \_\_\_\_\_

Data Translation software - SPO number: \_\_\_\_\_

serial number: \_\_\_\_\_ version: \_\_\_\_\_

PC make/model: \_\_\_\_\_

operating system: \_\_\_\_\_ version: \_\_\_\_\_

Windows version: \_\_\_\_\_

processor: \_\_\_\_\_ speed: \_\_\_\_\_

RAM: \_\_\_\_\_ hard disk space: \_\_\_\_\_

network/number of users: \_\_\_\_\_ disk cache: \_\_\_\_\_

graphics adapter: \_\_\_\_\_ data bus: \_\_\_\_\_

I have the following boards and applications installed in my system: \_\_\_\_\_

\_\_\_\_\_

I am encountering the following problem(s): \_\_\_\_\_

\_\_\_\_\_

\_\_\_\_\_

and have received the following error messages/codes: \_\_\_\_\_

\_\_\_\_\_

I have run the board diagnostics with the following results: \_\_\_\_\_

\_\_\_\_\_

You can reproduce the problem by performing these steps:

1. \_\_\_\_\_

2. \_\_\_\_\_

\_\_\_\_\_

3. \_\_\_\_\_

\_\_\_\_\_

\_\_\_\_\_

## E-Mail and Fax Support

You can also get technical support by e-mailing or faxing the Technical Support Department:

- **E-mail:** You can reach Technical Support at the following address: [tsupport@datx.com](mailto:tsupport@datx.com)

Ensure that you provide the following minimum information:

- Your name,
- Your company or organization,
- A phone number,
- An e-mail address where you can be reached,
- The hardware/software product you need help on,
- A summary of the issue you are experiencing,
- Your contract number, if applicable, and
- Your product serial number or purchase date.

Omitting any of the above information may delay our ability to resolve your issue.

- **Fax:** Photocopy and complete the form on [page 52](#), then fax Technical Support at the following number: (508) 481-8620.

Support requests from non-contract and out-of-warranty customers are processed with the same priority as telephone support requests.

## World-Wide Web

For the latest tips, software fixes, and other product information, you can always access our World-Wide Web site free of charge at the following address: <http://www.datatranslation.com>

## ***If Your Board Needs Factory Service***

If your board must be returned to Data Translation, perform the following steps:

1. Record the board's serial number, then contact the Customer Service Department at (508) 481-3700 (if you are in the USA) and obtain a Return Material Authorization (RMA).

If you are located outside the USA, call your local distributor for authorization and shipping instructions. The name and telephone number of your nearest distributor are listed in your Data Translation catalog.

All return shipments to Data Translation must be marked with the correct RMA number to ensure proper processing.

2. Using the original packing materials, if available, package the board as follows:
  - Wrap the board in an electrically conductive plastic material. Handle with ground protection. A static discharge can destroy components on the board.
  - Place in a secure shipping container.
3. Return the board to the following address, making sure the RMA number is visible on the outside of the box.

Customer Service Dept.  
Data Translation, Inc.  
100 Locke Drive  
Marlboro, MA 01752-1192

---

# Index

## A

accessories

- Camera Interface Module [4](#)
- EP261 cable [4](#)
- EP321 cable [4](#)
- EP332 cable [4, 27](#)
- EP337 cable [4, 35](#)
- STP15 screw terminal panel [4](#)

ActiveX control [3](#)

Adobe Acrobat Reader, using [13](#)

## C

cables

- EP261 [4](#)
- EP321 [4, 28](#)
- EP332 [4, 27](#)
- EP337 [4, 35](#)

CAMERA connector [31](#)

Camera Interface Module [4, 28](#)

checking system requirements [10](#)

CIM [4](#)

connecting signals

- to connector J1 [26](#)
- using the Camera Interface Module [28](#)
- using the EP332 cable [27](#)
- using the EP337 cable [35](#)
- using the STP15 [35](#)

conventions used [vi](#)

customer service [54](#)

## D

DT Vision Foundry [3](#)

DT3162 Device Driver [3](#)

DT3162 documentation, installing [13](#)

DT-Acquire2 [3, 40](#)

DT-Active Monochrome Frame

Grabber Control [3](#)

## E

e-mail support [53](#)

EP261 cable [4](#)

EP321 cable [4, 28](#)

EP332 cable [4, 27](#)

EP337 cable [4, 35](#)

expansion slot [10](#)

selection [18](#)

## F

factory service [54](#)

fax support [53](#)

## G

GLOBAL LAB Image/2 [3](#)

## H

help [45](#)

## **I**

inserting the board in the computer [18](#)  
installing the DT3162 documentation  
[13](#)  
installing the software [11](#)

## **J**

J1 connector [26](#)  
J2 connector [35](#)  
jumpers [32](#)

## **P**

pin assignments, CAMERA connector  
[31](#)

## **R**

related documents [vi](#)  
requirements [10](#)  
returning boards to the factory [54](#)  
RMA [54](#)

## **S**

screw terminal panel layout [36](#)  
selecting an expansion slot [18](#)  
service and support procedure [50](#)  
setting up the computer [17](#)  
slot selection [18](#)  
software supported [3](#)  
STP15 screw terminal panel [4](#), [35](#)  
support  
e-mail [53](#)  
fax [53](#)  
telephone [50](#)

World Wide Web [53](#)  
system requirements [10](#)

## **T**

technical support [50](#)  
e-mail [53](#)  
fax [53](#)  
telephone [50](#)  
World-Wide Web [53](#)  
telephone support [50](#)  
troubleshooting  
procedure [45](#)  
service and support procedure [50](#)  
troubleshooting table [46](#)

## **U**

unpacking the board [9](#)

## **V**

verifying board operation [39](#)

## **W**

World-Wide Web [53](#)