

DATA TRANSLATION

UM-19603-B

DT3145 ***User's Manual***

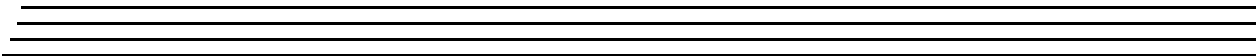
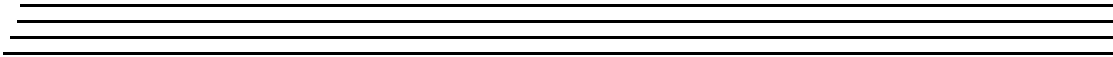

**Second Edition
June, 2003**

Copyright © 2003 by Data Translation, Inc.

All rights reserved.

Information furnished by Data Translation, Inc. is believed to be accurate and reliable; however, no responsibility is assumed by Data Translation, Inc. for its use; nor for any infringements of patents or other rights of third parties which may result from its use. No license is granted by implication or otherwise under any patent rights of Data Translation, Inc.

Use, duplication, or disclosure by the United States Government is subject to restrictions as set forth in subparagraph (c)(1)(ii) of the Rights in Technical Data and Computer software clause at 48 C.F.R, 252.227-7013, or in subparagraph (c)(2) of the Commercial computer Software - Registered Rights clause at 48 C.F.R., 52-227-19 as applicable. Data Translation, Inc., 100 Locke Drive, Marlboro, MA 01752.

Data Translation[®] and GLOBAL LAB[®] are registered trademarks, and Imaging OMNI CD[™], DT-Active Camera Link Frame Grabber[™], and DT Vision Foundry[™] are trademarks of Data Translation, Inc.

All other brand and product names are trademarks or registered trademarks of their respective companies.

Data Translation, Inc.
100 Locke Drive
Marlboro, MA 01752-1192
(508) 481-3700
www.datatranslation.com
Fax: (508) 481-8620
E-mail: info@datx.com

Radio and Television Interference

This equipment has been tested and found to comply with CISPR EN55022 Class A and EN50082-1 (CE) requirements and also with the limits for a Class A digital device, pursuant to Part 15 of the FCC Rules. These limits are designed to provide reasonable protection against harmful interference when the equipment is operated in a commercial environment. This equipment generates, uses, and can radiate radio frequency energy and, if not installed and used in accordance with the instruction manual, may cause harmful interference to radio communications. Operation of this equipment in a residential area is likely to cause harmful interference, in which case the user will be required to correct the interference at his own expense.

Changes or modifications to this equipment not expressly approved by Data Translation could void your authority to operate the equipment under Part 15 of the FCC Rules.

Note: This product was FCC-Certified under test conditions that included use of shielded cables and connectors between system components. It is important that you use shielded cables and connectors to reduce the possibility of causing interference to radio, television, and other electronic devices.

Canadian Department of Communications Statement

This digital apparatus does not exceed the Class A limits for radio noise emissions from digital apparatus set out in the Radio Interference Regulations of the Canadian Department of Communications.

Le présent appareil numérique n'émet pas de bruits radioélectriques dépassant les limites applicables aux appareils numériques de la class A prescrites dans le Règlement sur le brouillage radioélectrique édicté par le Ministère des Communications du Canada.

Table of Contents

About this Manual	vii
Intended Audience	vii
What You Should Learn from this Manual	vii
Conventions Used in this Manual	viii
Related Information	viii
Where to Get Help	x
Principles of Operation	1
Video Input	4
Camera Link Cameras Supported	4
Data Formats	4
Triggers	5
Area-Scan Mode	5
Line-Scan Mode	6
Controlling the Acquisition of Lines	6
Controlling the Acquisition of Lines and Frames ..	7
Look-Up Tables (LUTs)	8
Acquiring Images	10
Acquisition Type	10
Area-Scan Mode	10
Line-Scan Mode	11
Acquisition Mode	12
Data Transfer and Storage	14
Displaying Images	15
Source Origin	15
Overlays	16

Camera Control Output Signals	17
Expose Output Signal	17
Integrate Output Signal	18
Strobe Output Signal	19
General-Purpose Output Signal	20
Digital I/O Signals	21
Appendix A: Specifications	23
Appendix B: Connector Pin Assignments	27
J2 Connector	28
STP15 Connectors and Screw Terminals	30
Appendix C: Values for Use with the DT-Active Camera Link Frame Grabber Control	33
Index	41

About this Manual

This manual describes the features of the DT3145 frame grabber board and provides technical reference information.

Intended Audience

This document is intended for engineers, scientists, technicians, or others responsible for programming and/or using the DT3145 board to perform machine vision and/or image analysis operations. It is assumed that you have some familiarity with imaging principles and that you are familiar with the operating characteristics of your camera.

What You Should Learn from this Manual

This manual provides detailed information about the features of the DT3145 board. It is organized as follows:

- [“Principles of Operation,”](#) describes all of the supported features of the board.
- [Appendix A, “Specifications,”](#) lists the specifications of the board.
- [Appendix B, “Connector Pin Assignments,”](#) describes the pin assignments for the connectors on the DT3145 board and on the STP15 screw terminal panel.
- [Appendix C, “Values for Use with the DT-Active Camera Link Frame Grabber Control,”](#) lists the supported values for the DT3145 and the DT-Active Camera Link Frame Grabber™ Control.
- An index completes this manual.

Conventions Used in this Manual

The following conventions are used in this manual:

- Notes provide useful information that requires special emphasis, cautions provide information to help you avoid losing data or damaging your equipment, and warnings provide information to help you avoid catastrophic damage to yourself or your equipment.
- Items that you select or type are shown in **bold**.
- Courier font is used to represent source code.

Related Information

Refer to the following documents for more information on using the DT3145 board:

- *DT3145 Getting Started Manual* (UM-19601). This manual (GS3145.PDF), included on the Imaging OMNI CD™, describes how to set up, install, and wire signals to the DT3145 board, how to configure the DT3145 Device Driver, how to verify the operation of the board, and how to troubleshoot issues with the DT3145 board should they occur.
- *DT-Active Frame Grabber Controls Getting Started Manual* (UM-19336). This manual (DTFG.PDF), included on the Imaging OMNI CD, describes how to install, set up, and use the DT-Active Frame Grabber controls (including the DT-Active Camera Link Frame Grabber control) to develop imaging or machine vision application programs using Microsoft® Visual Basic® or Microsoft Visual C++®.
- *GLOBAL LAB Image/2 User's Manual* (UM-17790). This manual (GLIUM.PDF), included on the Imaging OMNI CD, describes how to use GLOBAL LAB® Image/2 to create scientific applications.

- *DT Vision Foundry User's Manual* (UM-17755). This manual, available from Data Translation, describes how to use DT Vision Foundry™ to create machine vision applications.
- Camera Link Specification, available from the Automated Imaging Association (AIA) at <http://machinevisiononline.org>.

In addition, you may want to read other material in order to gain a better understanding of image processing concepts, algorithms, and their applications. The Data Translation Technical Support Department recommends the following resources for understanding image processing concepts, processing, and coding:

Baxes, Gregory A. *Digital Image Processing, Principles & Applications*. New York: John Wiley & Sons, 1994. Introduction to image processing and hardware/software basics.

Benson, K. Blair, and Donald G. Fink. *HDTV Advanced TV for the 1990's*. New York: McGraw-Hill, 1990. Details high-definition television concepts.

Castleman, K. R. *Digital Image Processing*. Englewood Cliffs, NJ: Prentice-Hall, 1987. Explains major image processing concepts and mathematical concepts involved in digital image manipulation.

Gonzalez, Rafael C., and Paul Wintz. *Digital Image Processing*. Menlo Park, CA: Addison-Wesley, 1987. Explains major image processing concepts and mathematical concepts involved in digital image manipulation, including FFT processing, filtering operations, geometric functions, histograms, and linear equalization.

Lindley, Craig. *Practical Image Processing in C*. Somerset, NJ: John Wiley & Sons, Inc., 1991. Explains basic image processing techniques using C, provides many programming examples, covers TIFF and PICT file formats, and describes how to map images into VGA memory space.

Luther, Arch C. *Digital Video in the PC Environment*. New York: McGraw-Hill, 1991. Explains Digital Video Interactive (DVI) technology.

Pratt, William K. *Digital Image Processing*. Somerset, NJ: John Wiley & Sons, Inc., 1991. Detailed text on image processing, including morphological processing, feature extraction, image segmentation, and shape analysis.

Rosenfeld, Azriel, and Avinash C. Kak. *Digital Picture Processing*. New York: Academic Press, Inc., 1990. Describes image processing techniques and concepts.

Russ, John C. *Computer-Assisted Microscopy, The Measurement and Analysis of Images*. New York: Plenum Press.

Watkinson, John. *The Art of Digital Video*. Stoneham, MA: Focal Press, 1990. Provides an in-depth description of digital video fundamentals.

Where to Get Help

Should you run into problems installing or using the DT3145 board, the Data Translation Technical Support Department is available to provide technical assistance. Refer to the *DT3145 Getting Started Manual* for more information. If you are outside the U.S. or Canada, call your local distributor, whose number is listed in your Data Translation product handbook, or contact the Data Translation web site (www.datatranslation.com).

Principles of Operation

Video Input	4
Acquiring Images	10
Displaying Images	15
Camera Control Output Signals	17
Digital I/O Signals	21

This chapter describes the features of the DT3145 frame grabber board from a functional point of view. To aid the discussions in this chapter, refer to the block diagram of the DT3145, shown in [Figure 1](#).

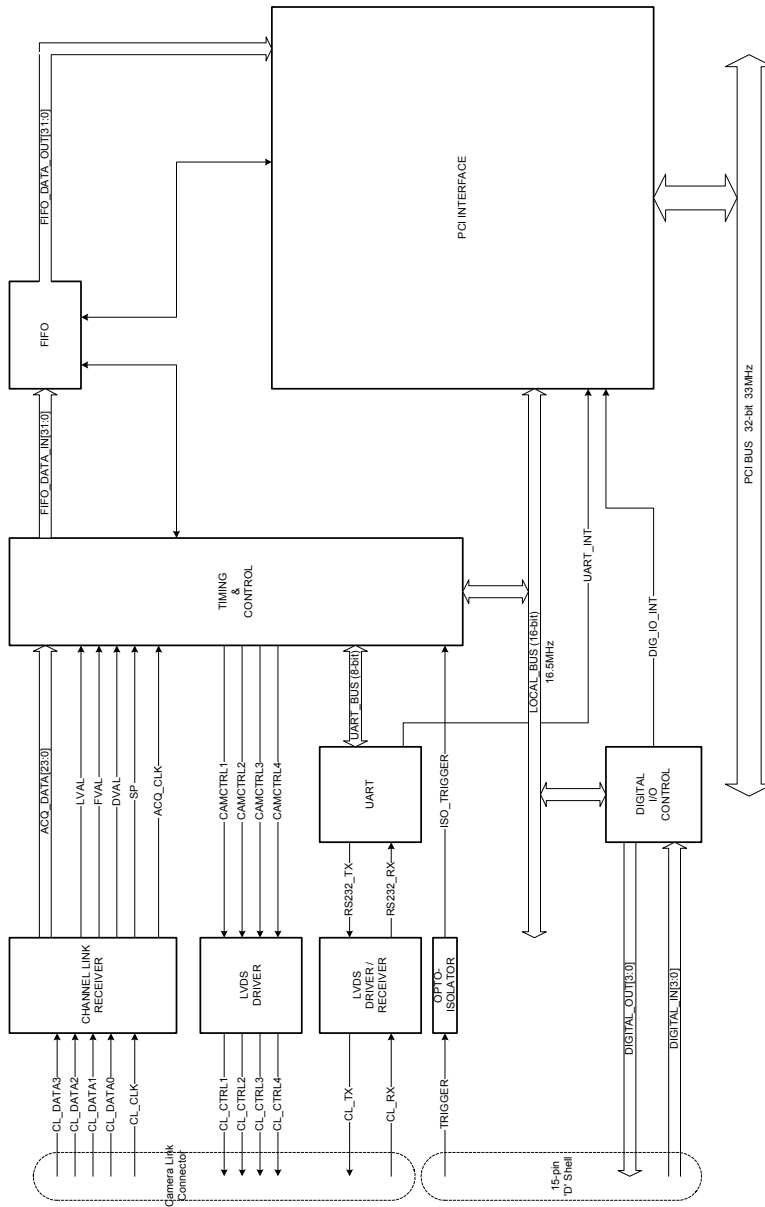

Figure 1: DT3145 Block Diagram

Video Input

This section describes the following aspects of the video input:

- Camera Link cameras supported,
- Data formats,
- Triggers, and
- Look-up tables (LUTs).

Camera Link Cameras Supported

The DT3145 frame grabber board supports Camera Link cameras that conform to the Base Mode Camera Link Specification and the Camera Link Serial I/O Port Specification. Supported Camera Link cameras include the Basler A202K, the Basler A102K, and the Dalsa Dalstar DS-11-1M28 camera.

Note: The list of supported cameras is constantly expanding. Refer to the Data Translation web site (www.datatranslation.com) for information on the cameras supported for use with the DT-Active Camera Link Frame Grabber control.

Data Formats

Using software, you can specify the data format in which your Camera Link camera acquires data. For the DT3145 frame grabber board, the following data formats are supported: single-port format (8-bit, 10-bit, 12-bit, 14-bit, or 16-bit monochrome), dual-port format (8-bit, 10-bit, or 12-bit monochrome), and RGB format (24-bit color).

The higher the number of bits that the camera supports, the better the granularity of the image (the more gray levels provided). For example, an 8-bit data format provides 256 shades of gray; a 10-bit data format provides 1024 shades of gray.

In the dual-port (also called dual-tap) formats, two pixels are acquired for each clock pulse. This allows your camera to transfer data twice as fast for a given clock rate or to run at a slower clock rate.

Note: When acquiring data, 8-bit data formats (single-port and dual-port) require 1 byte per pixel; 10-bit, 12-bit, 14-bit, and 16-bit data formats (single-port and dual-port) require 2 bytes per pixel; and RGB data formats require 4 bytes per pixel.

Triggers

The following sections describe how to use triggers to control the acquisition of ROIs in area-scan mode and the acquisition of lines in line-scan mode. Refer to [page 10](#) for more information about area-scan mode and line-scan mode.

Area-Scan Mode

In area-scan mode, you can use an ROI trigger to control the acquisition of ROIs. The DT3145 board supports both a software trigger and an external trigger input. The external trigger input is provided through pin 13 of connector J2 on the DT3145 board. You can access this signal using the STP15 screw terminal panel.

If you specify a software trigger (Internal) using software, the acquisition starts when you execute an acquisition command.

If you specify an external trigger using software, the acquisition is synchronized with a change-of-state on the external trigger input line. Through software, you can specify whether you want to acquire an ROI when a low-to-high (OnLowToHigh) transition occurs or when a high-to-low (OnHighToLow) transition occurs.

You can also specify whether to use a single external trigger event to start the acquisition of a series of ROIs (ExternalToStart), or whether to use a separate external trigger event to acquire each ROI in a series of ROIs (ExternalForEach).

Note: If you plan to use the camera control output signals, you must specify either an Internal trigger (for use when acquiring one ROI) or an ExternalForEach trigger (for use when acquiring one or more ROIs).

Line-Scan Mode

In line-scan mode, you can use a line trigger to control the acquisition of individual lines and/or a frame trigger to control the acquisition of the frames that are built by acquiring multiple lines.

Controlling the Acquisition of Lines

To control the acquisition of individual lines, connect an external line trigger to the external trigger input, which is provided through pin 13 of connector J2 on the DT3145 board. You can access this signal using the STP15 screw terminal panel.

Use software to specify the trigger type as ExternalForEach and to specify whether you want to acquire a line when a low-to-high (OnLowToHigh) transition occurs or when a high-to-low (OnHighToLow) transition occurs. The acquisition is synchronized with the change-of-state on the external trigger input line.

Note: If you do not want to use an external line trigger, you can specify the trigger type as Internal. The acquisition starts when you execute an acquisition command, and the lines are acquired as quickly as possible. If you specify an Internal trigger, the lines that you acquire may not be contiguous and the timing between lines may not be determinate.

Controlling the Acquisition of Lines and Frames

To control the acquisition of both individual lines and frames that are built by acquiring multiple lines, you use an external line trigger (set to ExternalForEach, as described in the previous section) to control the acquisition of individual lines and an external frame trigger to control the acquisition of frames.

The frame trigger input is provided through digital input line 0 (pin 1 of connector J2 on the DT3145 board). You can access this signal using the STP15 screw terminal panel. The frame trigger must have a minimum pulse width of 10 μ s.

If you enable the frame trigger using software, the acquisition is synchronized with a change-of-state on digital input line 0. Through software, you can specify whether you want to acquire a frame when a low-to-high (OnLowToHigh) transition occurs or when a high-to-low (OnHighToLow) transition occurs.

Notes: The DT3145 board first waits for the frame trigger event to occur, then waits for the line trigger event to occur.

If you do not want to use an external line trigger, you can specify the trigger type as Internal. The acquisition starts when you execute an acquisition command, and the lines are acquired as quickly as possible. If you specify an Internal trigger, the lines that you acquire may not be contiguous and the timing between lines may not be determinate.

If you are acquiring multiple frames of multiple lines, the time between the acquisition of each frame is less than 1 ms.

Look-Up Tables (LUTs)

The DT3145 board provides two LUTs (0 and 1) that you can use to change the value of an incoming pixel or affect the displayed image. When the LUT receives an input pixel value, it modifies this value according to the corresponding value in the LUT.

By default, LUT 0 is the Identity LUT (the image is unaltered) and LUT 1 is the Inverse LUT (the image is inverted - black becomes white and white becomes black). In addition, your Camera Link camera may be shipped with LUTs that allow you to perform pixel point operations, such as image multiplication and division and brightness correction. You can use the camera configuration software provided with your camera to specify which of these LUTs you want to use.

Note: If you do not get the results you expect using the default LUT 0 or the default LUT 1, try using software to load one of the LUT files shipped on the Imaging ONMI CD. These LUT files are located in C:\Program Files\Data Translation\DT3145\LUTFiles, by default.

It is strongly recommended that you do not open or modify these LUT files. If you do, the results will be unpredictable.

Acquiring Images

This section describes the following topics related to acquiring images:

- Acquisition type (area-scan or line-scan),
- Acquisition mode, and
- Data transfer and storage.

Acquisition Type

You can use software to specify whether to perform an area-scan operation or a line-scan operation, as described in the following sections.

Area-Scan Mode

In an area-scan operation, you acquire regions of interest (ROIs), also called areas of interest or AOIs. Using software, you can specify the size of your ROI.

Note: The maximum size that you can specify for the ROI depends on the Active Pixel Count and Active Line Count supported by your camera. To ensure that your ROI is valid, it is recommended that before you specify the size of your ROI, you use software to specify the Active Pixel Count and Active Line Count. Refer to your camera documentation for more information.

You can use the following settings to define the size of the ROI:

- **ROI Left** – The position of the first pixel of the ROI that you want to acquire.
- **ROI Width** – The number of pixels in each line of the ROI that you want to acquire.
- **ROI Top** – The position of the first line of the ROI that you want to acquire.
- **ROI Height** – The number of lines in the ROI that you want to acquire.

Line-Scan Mode

In a line-scan operation, you can acquire a single line or you can acquire multiple lines to build your own frame.

You can use the following settings to define the size of the line/frame:

- **Line-Scan Left** – The position of the first pixel of each line that you want to acquire.
- **Line-Scan Width** – The number of pixels in each line that you want to acquire.
- **Line-Scan Frame Height** – The number of lines that you want to acquire.

Note: The DT-Active Camera Link Frame Grabber control treats a single line as a frame of one line. Therefore, you must always specify the Line-Scan Frame Height, even if the value is 1.

Acquisition Mode

Using software, you can specify one of the following ways to acquire ROIs or frames of lines:

- **Single-pass synchronous mode** – The DT3145 board acquires a specified number of ROIs/frames, saves the appropriate data to buffers in memory, then stops.

In single-pass synchronous mode, all system resources are devoted to the acquisition until the specified data has been saved; you cannot perform another operation until the synchronous acquisition completes, including stopping the operation.

For example, assume that you specify the acquisition type as area-scan, the acquisition mode as single-pass synchronous mode, and the number of buffers as 3. When the acquisition operation is started, the software allocates three buffers, acquires the first ROI and saves it in buffer 1, acquires the second ROI and saves it in buffer 2, acquires the third ROI and saves it in buffer 3, then stops the operation. You can then manipulate the data in the buffers as needed.

Specify `SinglePassSync` in software to use this mode.

- **Single-pass asynchronous mode** – Like single-pass synchronous mode, the DT3145 board acquires a specified number of ROIs/frames, saves the appropriate data to buffers in memory, then stops.

Unlike single-pass synchronous mode, the operation starts and then returns control to you immediately, allowing you to perform other operations while data is acquired. You can stop the operation before all the data has been acquired, if you wish, using software.

Specify `SinglePassAsync` in software to use this mode.

- **Continuous asynchronous mode** – The DT3145 board continuously acquires an unlimited number of ROIs/frames and saves the appropriate data to buffers in memory until you stop the acquisition. You are responsible for managing the data in the buffers so that it is retrieved before the buffer is overwritten.

Continuous mode is an asynchronous acquisition, where the operation starts and then returns control to you immediately, allowing you to perform other operations while data is acquired.

For example, assume that you specified the acquisition type as area-scan, the acquisition mode as continuous asynchronous mode, and the number of buffers as 3. When the acquisition operation is started, the software allocates three buffers, acquires the first ROI and stores it in buffer 1, acquires the second ROI and stores it in buffer 2, then acquires the third ROI and stores it in buffer 3. Then, the process repeats so that the fourth ROI is stored in buffer 1 (overwriting any data previously stored there), the fifth ROI is stored in buffer 2 (overwriting any data previously stored there), and so on. The operation repeats until you stop it. You must manage the buffers so that the data in buffers 1 through 3 is read before the buffers are overwritten.

Specify `ContinuousAsync` in software to use this mode.

Note: During asynchronous acquisitions, your application program is notified by Active-X events that various conditions (such as when one or more buffers is filled or when the acquisition has completed) occur.

Data Transfer and Storage

The DT3145 board uses the scatter/gather memory management architecture so that memory locations do not have to be contiguous. The board operates as a PCI bus initiator/master using burst mode for data transfers to memory. Typical video transfer rates are 80 MB/s (maximum 132 MB/s). Data is stored in the same format as the video input: single-port (8-bit, 10-bit, 12-bit, 14-bit, and 16-bit monochrome), dual-port (8-bit, 10-bit, and 12-bit monochrome), or RGB (24-bit color).

Displaying Images

This section describes the following topics related to displaying images:

- Source origin, and
- Overlays.

Source Origin

Because the DT3145 frame grabber board supports large ROI/frame sizes, your acquired ROI/frame may be larger than your display window. In this case, you cannot display the entire ROI/frame. By default, the upper left corner of the display window (the source origin) and the upper left corner of the acquired ROI/frame are the same. If you want to display a different part of the ROI/frame, you can use software to select another point in the acquired ROI/frame as the source origin. [Figure 2](#) illustrates adjusting the source origin.

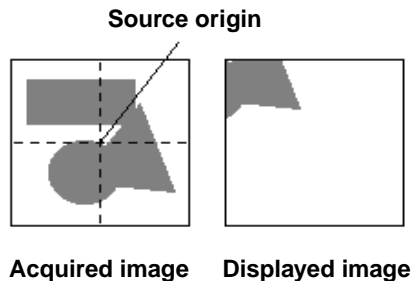

Figure 2: Source Origin Example

The source origin consists of both an x-pixel position and a y-pixel position in the ROI/frame. In the x-direction, values range from 0 (the default) to the ROI width. In the y-direction, values range from 0 (the default) to the ROI height. When set, the displayed ROI/frame shifts to the new position.

Note: If you want your end-user to view the entire image, you can add scroll bars to your application program.

Overlays

For the DT3145 board, you can use software to add overlays, such as text or graphics, on top of another displayed image that was acquired. Overlays are useful for creating animation or to display helpful information for the user.

Camera Control Output Signals

The DT3145 board provides four camera control output lines that you can use to generate one or more of the following events (if your camera supports them):

- An expose output signal to control the exposure time for asynchronous reset cameras. This signal is typically used in area-scan mode.
- An integrate output signal to control the exposure time for line-scan cameras. This signal is typically used in line-scan mode.
- A strobe output signal to control lighting.
- A general-purpose output signal.

Note: Refer to your camera documentation to determine which of these signals are required by your camera and which particular camera control output lines your camera uses.

The following sections describe each of the camera control signals in more detail.

Expose Output Signal

If your camera supports expose output signals, you can use one of the camera control output lines to generate an expose output pulse. If you enable the expose output pulse through software, you can also use software to specify the following settings:

- **Polarity** – The polarity of the expose output pulse can be ActiveHigh (the expose output pulses are low-to-high going signals) or ActiveLow (the expose output pulses are high-to-low going signals).

- **Pulse width** – The width of the expose output pulse is the time that the pulse is in its active state (determined by the polarity).
- **Time delay** – You can specify a time delay between the trigger event and the beginning of the expose output pulse.

Notes: The pulse width and time delay are determined by multiplying the value you specify by the time granularity, which can be 1 μ s, 10 μ s, 100 μ s, or 1,000 μ s. For example, if the time granularity is set to 1 μ s and you specify a value of 100 for the pulse width, the actual width of the expose output pulse is 100 μ s.

For best results, it is recommended that you use the smallest time granularity possible.

Integrate Output Signal

If your camera supports integrate output signals, you can use one of the camera control output lines to generate an integrate output pulse. If you enable the integrate output pulse through software, you can also use software to specify the following settings:

- **Polarity** – The polarity of the integrate output pulse can be ActiveHigh (the integrate output pulses are low-to-high going signals) or ActiveLow (the integrate output pulses are high-to-low going signals).
- **Pulse width** – The width of the integrate output pulse is the time that the pulse is in its active state (determined by the polarity).
- **Time delay** – You can specify a time delay between the trigger event and the beginning of the integrate output pulse.

Notes: The pulse width and time delay are determined by multiplying the value you specify by the time granularity, which can be 1 μs , 10 μs , 100 μs , or 1,000 μs . For example, if the time granularity is set to 1 μs and you specify a value of 100 for the pulse width, the actual width of the integrate output pulse is 100 μs .

For best results, it is recommended that you use the smallest time granularity possible.

Strobe Output Signal

If your camera supports strobe output signals, you can use one of the camera control output lines to generate a strobe output pulse. If you enable the strobe output pulse through software, you can also use software to specify the following settings:

- **Polarity** – The polarity of the strobe output pulse can be ActiveHigh (the strobe output pulses are low-to-high going signals) or ActiveLow (the strobe output pulses are high-to-low going signals).
- **Pulse width** – The width of the strobe output pulse is the time that the pulse is in its active state (determined by the polarity).
- **Time delay** – You can specify a time delay between the trigger event and the beginning of the strobe output pulse.

Notes: The pulse width and time delay are determined by multiplying the value you specify by the time granularity, which can be 1 μs , 10 μs , 100 μs , or 1,000 μs . For example, if the time granularity is set to 1 μs and you specify a value of 100 for the pulse width, the actual width of the strobe output pulse is 100 μs .

For best results, it is recommended that you use the smallest time granularity possible.

You can also access the strobe output signal through the STROBE screw terminal on the STP15 screw terminal panel. This allows you to provide lighting when your camera does not provide a strobe output signal. For more information, refer to [page 30](#).

General-Purpose Output Signal

If your camera supports general-purpose output signals, you can use one of the camera control output lines to generate either a high-level output pulse or a low-level output pulse.

Digital I/O Signals

The DT3145 board provides four dedicated digital input lines and four dedicated output lines. Pins 1, 2, 3, and 4 of connector J2 on the DT3145 board are provided for the digital input signals. Pins 6, 7, 8, and 11 of connector J2 on the DT3145 board are provided for the digital output signals. To access the digital I/O signals, use the STP15 screw terminal panel and EP337 cable.

The digital I/O signals are non-isolated, TTL-level signals that you can use for any purpose, such as controlling or actuating external devices. A bit value of 0 identifies a low TTL level; a bit value of 1 identifies a high TTL level.

The DT3145 can generate a PCI-bus interrupt when one or more of the digital input lines changes state. This feature is useful when you want to monitor critical signals or when you want to signal the host computer to transfer data to or from the board. You enable the interrupts on a line-by-line basis using software.

You can use software to read or write to the digital I/O lines and to determine which digital input lines changed state.

Note: If you are performing a line-scan operation and want to control the acquisition of the frames that are built by acquiring multiple lines, you can use digital input line 0 as a frame trigger. For more information, refer to [page 7](#). If you use digital input line 0 as a frame trigger, digital input lines 1, 2, and 3 are disabled.



Specifications

Table 1 lists the digital output and strobe output electrical specifications for the DT3145 board.

Table 1: Digital Output/Strobe Output Electrical Specifications

Feature	Minimum Specification	Maximum Specification
High-Level Output Current (IOH)	N/A	24 mA
Low-Level Output Current (IOL)	N/A	24 mA
High-Level Output Voltage (VOH)	4 V	N/A
Low-Level Output Voltage (VOL)	N/A	0.44 V

Table 2 lists the digital input electrical specifications for the DT3145 frame grabber board.

Table 2: Digital Input Electrical Specifications

Feature	Minimum Specification	Maximum Specification
Input High Level (V_{IH})	2.0 V	5.0 V
Input Low Level (V_{LL})	-0.3 V	0.8 V
Input Capacitance (C_{IN})	N/A	6 pF

Table 3 lists the power specifications for the DT3145 board.



Table 3: Power Specifications

Feature	Specification
+5 V Typical: Maximum:	40 mA 50 mA
+3.3 V Typical: Maximum:	250 mA 375 mA
Total Power Typical: Maximum:	1 W 1.5 W

Table 4 lists the physical and environmental specifications for the DT3145 board.

Table 4: Physical and Environmental Specifications

Feature	Specification
Dimensions Overall including faceplate and connectors:	10.6 cm x 17.5 cm (4.2 in x 6.9 in)
PCB:	10.6 cm x 16.1 cm (4.2 in x 6.3 in)
Weight	130 g (4.6 ounces)
Operating temperature	0 to 50° C (32 to 122° F)
Storage temperature	-25 to 70° C (-13 to 158° F)
Humidity	0 to 90%, noncondensing

Table 5 lists the specifications for the connectors on the DT3145 board.

Table 5: Connector Specifications

Connector	Specifications
DT3145 J1 Connector	Camera Link MDR-26 connector
DT3145 J2 Connector	AMP 15-pin subminiature-D connector (HTEMP, R/A, REC) part number 748390-5
DT3145 J2 Mating Connector	AMP 15-pin male subminiature-D connector part number 749798-1



Connector Pin Assignments

J2 Connector	28
STP15 Connectors and Screw Terminals.....	30

J2 Connector

The DT3145 has a 15-pin subminiature-D connector, labelled J2, which accommodates the digital I/O, trigger input, strobe output, and +5 V output signals. [Figure 3](#) illustrates the pin locations of connector J2. [Table 4](#) describes the pin assignments of this connector.

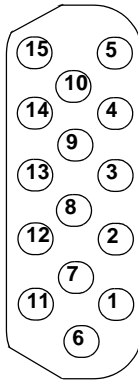

Figure 3: DT3145 - Connector J2

Table 6: DT3145 - J2 Connector Pin Assignments

Pin	Description	Pin	Description
1	Digital Input 0	2	Digital Input 1
3	Digital Input 2	4	Digital Input 3
5	Ground	6	Digital Output 0
7	Digital Output 1	8	Digital Output 2
9	Not Connected	10	Ground
11	Digital Output 3	12	Strobe Output
13	Trigger Input	14	+5 V (250 mA) Output
15	Ground		

B

STP15 Connectors and Screw Terminals

The STP15 contains one 15-pin connector and two screw terminal blocks (TB1 and TB2).

The 15-pin connector provides access to the signals from connector J2 on the DT3145 board. [Figure 4](#) shows the layout of the STP15 and the screw terminal descriptions.

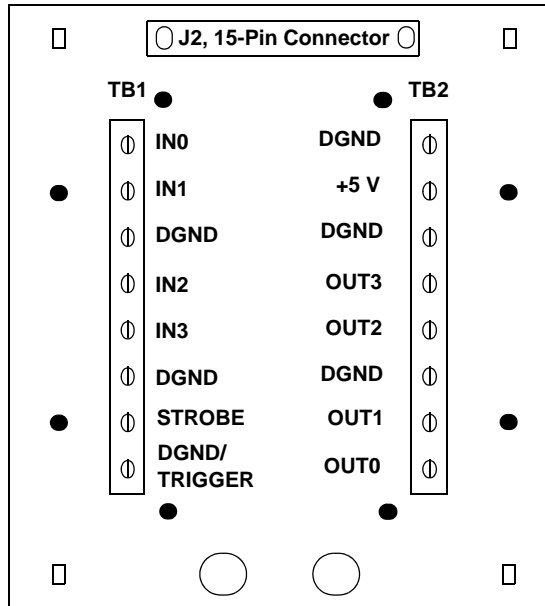

Figure 4: Layout of the STP15 Screw Terminal Panel

Notes: In [Figure 4](#), IN refers to digital input signals, OUT refers to digital output signals, DGND/TRIGGER refers to the trigger input signal, STROBE refers to the strobe output signal, DGND refers to digital ground signals, and +5 V refers to a +5 V (250 mA) output signal from the DT3145 board.

The dark filled circles in [Figure 4](#) represent holes that you can use to mount the STP15 on a DIN rail. To mount the STP15 on a DIN rail, you need two DIN rail mount adapters (Phoenix Contact part number 1201578 or Data Translation part number 18083), and four thread form screws (Bossard part number BN2724M3x8 or Data Translation part number 18193).



***Values for Use with the
DT-Active Camera Link
Frame Grabber Control***

Table 7 lists the DT3145 values for each property of the DT-Active Camera Link Frame Grabber control.

Table 7: DT3145 Values for the DT-Active Camera Link Frame Grabber Control

Category	Property	DT3145 Values	Default
General Properties	ActiveLUT	0 or 1	0
	Timeout	0 to 65535 s, in increments of 1 s	10
	DisplayMode	DDI GDI	DDI
	DrawXOrigin	0 to ROIWidth	0
	DrawYOrigin	0 to ROIHeight	0
Camera Control Output Properties	TimeGranularity ^a	1 μ s 10 μ s 100 μ s 1000 μ s	1 μ s
	CameraControlOutput1	Expose Integrate Strobe Logical_Hi Logical_Lo	Logical_Lo
	CameraControlOutput2	Expose Integrate Strobe Logical_Hi Logical_Lo	Logical_Lo

Table 7: DT3145 Values for the DT-Active Camera Link Frame Grabber Control

Category	Property	DT3145 Values	Default
Camera Control Output Properties (cont.)	CameraControlOutput3	Expose Integrate Strobe Logical_Hi Logical_Lo	Logical_Lo
	CameraControlOutput4	Expose Integrate Strobe Logical_Hi Logical_Lo	Logical_Lo
Expose Output Signal Properties	ExposeEnabled	TRUE or FALSE	FALSE
	ExposePulseWidth	1 to 65535, in increments of 1 ^{b, c}	100
	ExposePolarity	ActiveHigh ActiveLow	ActiveHigh
	ExposeDelay	1 to 65535, in increments of 1 ^{b, c}	1
Integrate Output Signal Properties	IntegrateEnabled	TRUE or FALSE	FALSE
	IntegratePulseWidth	1 to 65535, in increments of 1 ^{b, c}	100
	IntegratePolarity	ActiveHigh ActiveLow	ActiveHigh
	IntegrateDelay	1 to 65535, in increments of 1 ^{b, c}	1



Table 7: DT3145 Values for the DT-Active Camera Link Frame Grabber Control

Category	Property	DT3145 Values	Default
Strobe Output Signal Properties	StrobeEnabled	TRUE or FALSE	FALSE
	StrobePulseWidth	1 to 65535, in increments of 1 ^{b, c}	100
	StrobePolarity	ActiveHigh ActiveLow	ActiveHigh
	StrobeDelay	1 to 65535, in increments of 1 ^{b, c}	1
Trigger Properties	TriggerType	Internal ExternalToStart ExternalForEach	Internal
	TriggerTransition	OnHighToLow OnLowToHigh	OnLowToHigh
Digital Image Properties	ActivePixelCount	1 to 16384, in increments of 1 ^d	640
	ActiveLineCount	1 to 16384, in increments of 1 ^d	480
	AcquireType	AreaScan LineScan	AreaScan
	DataFormat ^d	SingleMono8Bit SingleMono10Bit SingleMono12Bit SingleMono14Bit SingleMono16Bit DualMono8Bit DualMono10Bit DualMono12Bit RGB32	SingleMono8Bit

Table 7: DT3145 Values for the DT-Active Camera Link Frame Grabber Control

Category	Property	DT3145 Values	Default
Digital I/O Property	InputLineEventMask	0 to 15, in increments of 1	0
Region of Interest Properties	RoiLeft ^d	For single monochrome data formats: 0 to 4095, in increments of 1 For dual monochrome data formats: 0 to 4094, in increments of 2 For RGB32 data format: 0 to 2047, in increments of 1	0
	RoiWidth ^d	For 8-bit monochrome data format: 8 to 2048, in increments of 8 or 2064 to 4096, in increments of 16 For 10-bit, 12-bit, 14-bit, and 16-bit monochrome data formats: 8 to 4096, in increments of 8 For RGB32 data format: 8 to 2048, in increments of 8	640



Table 7: DT3145 Values for the DT-Active Camera Link Frame Grabber Control

Category	Property	DT3145 Values	Default
Region of Interest Properties (cont.)	RoiTop ^d	For monochrome data formats: 0 to 4095, in increments of 1 For RGB32 data format: 0 to 2047, in increments of 1	0
	RoiHeight ^d	For monochrome data formats: 1 to 4096, in increments of 1 For RGB32 data format: 1 to 2048, in increments of 1	1
Line Scan Properties	LineScanLeft	0 to 4095, in increments of 1	0
	LineScanWidth	8 to 16384, in increments of 8	640
	LineScanFrameHeight	1 to 16384, in increments of 1	1
	LineScanFrameTrigger Enabled	TRUE or FALSE	FALSE
	LineScanFrameTrigger Transition	OnHighToLow OnLowToHigh	OnLowToHigh

Table 7: DT3145 Values for the DT-Active Camera Link Frame Grabber Control

Category	Property	DT3145 Values	Default
Overlay Properties	OverlayBitmapFile	The path to the overlay file.	N/A
	OverlayColorKey	To specify an absolute color, use the format 0x00BBGGRR. To specify a system color, use the format 0x800000xx, where xx is the system color index.	0
	OverlayEnabled	TRUE or FALSE	FALSE

- a. For best results, it is recommended that you use the smallest time granularity possible.
- b. The value you specify is used with the TimeGranularity property to determine the setting for this property.
- c. The longest delay of any of the camera control output signals added to the longest pulse width of any of the camera control output signals must be less than or equal to 65,535.
- d. This value also depends on your camera. Refer to your camera documentation for more information.



Index

A

AcquireType property 36
acquisition modes 12
acquisition type 10
ActiveLineCount property 36
ActiveLUT property 34
ActivePixelCount property 36
area-scan acquisition 10

B

block diagram 2

C

camera control output lines 17
camera control output properties 34
CameraControlOutput1 property 34
CameraControlOutput2 property 34
CameraControlOutput3 property 35
CameraControlOutput4 property 35
cameras supported 4
change of state 21
connector J2 28, 30
continuous mode 13
conventions used viii

D

data formats 4
data storage 14
data transfer 14
DataFormat property 36
digital I/O properties 37
digital I/O signals 21
digital image properties 36
digital input specifications 24
digital output specifications 24
digital video formats 4
digital video input 4
DisplayMode property 34
DrawXOrigin property 34
DrawYOrigin property 34

E

environmental specifications 25
expose output signal 17
expose output signal properties 35
ExposeDelay property 35
ExposeEnabled property 35
ExposePolarity property 35
ExposePulseWidth property 35

F

formats 4
frames of lines 11

G

general properties 34
general-purpose output signal 20

I

InputLineEventMask property 37
integrate output signal 18
integrate output signal properties 35
IntegrateDelay property 35
IntegrateEnabled property 35
IntegratePolarity property 35
IntegratePulseWidth property 35
interrupts 21

J

J2 connector 28, 30

L

lines 11
line-scan acquisition 10
line-scan properties 38
LineScanFrameHeight property 38
LineScanFrameTriggerEnabled
property 38
LineScanFrameTriggerTransition
property 38
LineScanLeft property 38
LineScanWidth property 38
look-up tables 8
LUT 8

O

origin, source 15
output signals
expose 17
from camera control output lines 17
general-purpose 20
integrate 18
strobe 19
overlay properties 39
OverlayBitmapFile property 39
OverlayColorKey property 39
OverlayEnabled property 39
overlays 16

P

physical specifications 25
pin assignments of connector J2 28
pixels, modifying value 8
polarity
expose output signal 17
integrate output signal 18
strobe output signal 19
power specifications 25
properties
AcquireType 36
ActiveLineCount 36
ActiveLUT 34
ActivePixelCount 36
CameraControlOutput1 34
CameraControlOutput2 34
CameraControlOutput3 35
CameraControlOutput4 35
DataFormat 36
DisplayMode 34
DrawXOrigin 34
DrawYOrigin 34

ExposeDelay 35
ExposeEnabled 35
ExposePolarity 35
ExposePulseWidth 35
InputLineEventMask 37
IntegrateDelay 35
IntegrateEnabled 35
IntegratePolarity 35
IntegratePulseWidth 35
LineScanFrameHeight 38
LineScanFrameTriggerEnabled 38
LineScanFrameTransition 38
LineScanLeft 38
LineScanWidth 38
OverlayBitmapFile 39
OverlayColorKey 39
OverlayEnabled 39
RoiHeight 38
RoiLeft 37
RoiTop 37
RoiWidth 37
StrobeDelay 36
StrobeEnabled 36
StrobePolarity 36
StrobePulseWidth 36
TimeGranularity 34
Timeout 34
TriggerTransition 36
TriggerType 36
pulse width
 expose output signal 18
 integrate output signal 18
 strobe output signal 19

R

region of interest 10
region of interest properties 37
related documents viii
ROI 10
RoiHeight property 38
RoiLeft property 37
RoiTop property 37
RoiWidth property 37

S

screw terminal blocks 30
screw terminal panel layout 30
single-pass asynchronous mode 12
single-pass synchronous mode 12
source origin 15
specifications
 digital input 24
 digital output 24
 environmental 25
 physical 25
 power 25
STP15 screw terminal panel 30
strobe output signal 19
strobe output signal properties 36
StrobeDelay property 36
StrobeEnabled property 36
StrobePolarity property 36
StrobePulseWidth property 36
suggested reading ix

T

time delay

 expose output signal [18](#)

 integrate output signal [18](#)

 strobe output signal [19](#)

TimeGranularity property [34](#)

Timeout property [34](#)

trigger properties [36](#)

triggers [5](#)

TriggerTransition property [36](#)

TriggerType property [36](#)

V

video formats [4](#)

video input [4](#)

X

x-coordinate, *see* source origin

Y

y-coordinate, *see* source origin