

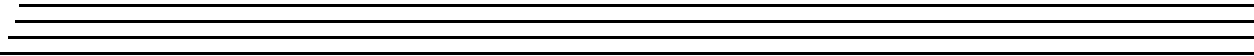

UM-19601-B

DT3145 Getting Started Manual

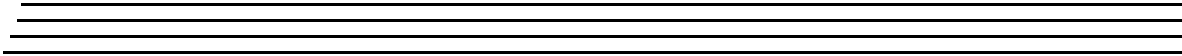
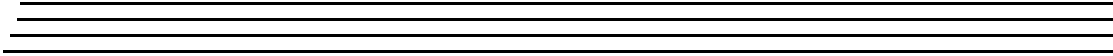

**Second Edition
June, 2003**

Copyright © 2003 by Data Translation, Inc.

All rights reserved.

Information furnished by Data Translation, Inc. is believed to be accurate and reliable; however, no responsibility is assumed by Data Translation, Inc. for its use; nor for any infringements of patents or other rights of third parties which may result from its use. No license is granted by implication or otherwise under any patent rights of Data Translation, Inc.

Use, duplication, or disclosure by the United States Government is subject to restrictions as set forth in subparagraph (c)(1)(ii) of the Rights in Technical Data and Computer software clause at 48 C.F.R, 252.227-7013, or in subparagraph (c)(2) of the Commercial computer Software - Registered Rights clause at 48 C.F.R., 52-227-19 as applicable. Data Translation, Inc., 100 Locke Drive, Marlboro, MA 01752

Data Translation[®] and GLOBAL LAB[®] are registered trademarks and Imaging OMNI CD[™], DT Vision Foundry[™], and DT-Active Camera Link Frame Grabber[™] are trademarks of Data Translation, Inc.

All other brand and product names are trademarks or registered trademarks of their respective companies.

Data Translation, Inc.
100 Locke Drive
Marlboro, MA 01752-1192
(508) 481-3700
www.datatranslation.com
Fax: (508) 481-8620
E-mail: info@datx.com

Table of Contents

About this Manual	v
Intended Audience.....	v
What You Should Learn from this Manual.....	v
Conventions Used in this Manual	vi
Related Information.....	vi
Where to Get Help	vii
Chapter 1: Overview	1
Key Features	2
Supported Software	4
Accessories	5
Getting Started Procedure.....	6
Chapter 2: Preparing to Use the DT3145	7
Unpacking	9
Checking the System Requirements	10
Installing the Software.....	11
Viewing the DT3145 Documentation	13
Chapter 3: Installing the Board and Configuring the Device Driver	15
Installing the Board	17
Setting up the Computer	17
Selecting an Expansion Slot.....	18
Configuring the Trigger Selection Jumper.....	18
Inserting the DT3145 Board in the Computer.....	21
Loading and Configuring the Device Driver	23

Chapter 4: Connecting Signals	25
Connecting a Camera.....	28
Connecting Signals to Connector J2	29
Chapter 5: Verifying Board Operation	33
Overview	35
Using DT-AcquireCL.....	36
Chapter 6: Troubleshooting	39
General Checklist	41
Service and Support.....	46
Telephone Technical Support.....	46
E-Mail and Fax Support.....	48
World-Wide Web.....	48
If Your Board Needs Factory Service.....	49
Index	51

About this Manual

This manual describes how to get started using a DT3145 frame grabber board.

Intended Audience

This document is intended for engineers, scientists, technicians, or others responsible for setting up a DT3145 board to perform machine vision and/or image analysis operations. It is assumed that you are familiar with the Windows® 2000 or Windows XP operating environment on the IBM® PC or compatible computer platform and with the operating characteristics of your Camera Link camera.

What You Should Learn from this Manual

This manual will help you install and set up your board and required software successfully. It is organized as follows:

- [Chapter 1, “Overview,”](#) describes the key features of the DT3145 hardware and software, and provides an overview of the getting started procedure.
- [Chapter 2, “Preparing to Use the DT3145,”](#) describes how to unpack the board and software, check system requirements, install the DT3145 software, and view the DT3145 documentation online.
- [Chapter 3, “Installing the Board and Configuring the Device Driver,”](#) describes how to install the DT3145 board and configure the device driver in Windows 2000 and Windows XP.
- [Chapter 4, “Connecting Signals,”](#) describes how to connect the camera to the board and how to connect signals to the board.
- [Chapter 5, “Verifying Board Operation,”](#) describes how to verify the board’s operation using DT-AcquireCL.

- [Chapter 6, “Troubleshooting,”](#) describes how to resolve issues with the DT3145 board should they occur.
- An index completes this manual.

Conventions Used in this Manual

The following conventions are used in this manual:

- Notes provide useful information that requires special emphasis, cautions provide information to help you avoid losing data or damaging your equipment, and warnings provide information to help you avoid catastrophic damage to yourself or your equipment.
- Items that you select or type are shown in **bold**.
- `Courier font` is used to represent source code.

Related Information

Refer to the following documents for more information on using a DT3145 board:

- The *DT3145 User’s Manual* (UM-19603). This manual (UM3145.PDF), included on the Imaging OMNI CD™, describes the features of the DT3145 board in detail.
- *DT-Active Frame Grabber Controls Getting Started Manual* (UM-19336). This manual (DTFG.PDF), included on the Imaging OMNI CD, describes how to install, set up, and use the DT-Active Frame Grabber controls (including the DT-Active Camera Link Frame Grabber™ control) to develop imaging or machine vision application programs using Microsoft® Visual Basic® or Microsoft Visual C++®.

- *GLOBAL LAB Image/2 User's Manual* (UM-17790). This manual (GLIUM.PDF), included on the Imaging OMNI CD, describes how to use GLOBAL LAB® Image/2 to create scientific applications.
- *DT Vision Foundry User's Manual* (UM-17755). This manual, available from Data Translation, describes how to use DT Vision Foundry™ to create machine vision applications.
- Camera Link Specification, available from the Automated Imaging Association (AIA) at <http://machinevisiononline.org>.

Where to Get Help

Should you run into problems installing or using a DT3145 board, the Technical Support Department is available to provide technical assistance. Refer to [Chapter 6 starting on page 39](#) for more information. If you are outside the United States or Canada, call your local distributor, whose number is listed in your Data Translation product handbook.



Overview

Key Features	2
Supported Software	4
Accessories	5
Getting Started Procedure.....	6

Key Features

Key features of the DT3145 frame grabber board are summarized as follows:

- Operates on the 32-bit, 33 MHz PCI local bus interface.
- Accepts a single Camera Link-compatible digital source operating in area-scan or line-scan mode.
- Acquires and stores data in single-port format (8-bit, 10-bit, 12-bit, 14-bit, and 16-bit monochrome), dual-port format (8-bit, 10-bit, and 12-bit monochrome), or RGB format (24-bit color).
- In area-scan mode, acquires regions of interest (ROIs), also called areas of interest or AOIs, that are 8 to 4,096 pixels wide by 1 to 4,096 lines high, depending on your camera.
- In line-scan mode, acquires lines that contain 8 to 16,384 pixels, depending on your camera. You can acquire either a single line or multiple lines to build your own frame.
- Acquires data at frequencies up to 66 MHz, determined by the Camera Link clock.
- Accepts an external trigger (either isolated or TTL) with software-selectable polarity.
- Provides two programmable look-up-tables (LUTs), each with three 256 x 8-bit sections that correspond to input ports A, B, and C.
- Provides four, software-selectable camera control output signals, which you can program to output the following:
 - An expose output signal to control the exposure time for asynchronous reset cameras.
 - An integration signal to control the exposure time for line-scan cameras.
 - A strobe output signal to control lighting.
 - A general-purpose output signal.

- Accepts up to four TTL digital input signals which can generate a PCI interrupt on a change of state.
- Provides up to four TTL digital output signals.
- Provides an asynchronous, serial communication port for camera setup.
- Supports overlays.

Supported Software

The following software is available for use with the DT3145 frame grabber board:

- **DT3145 Device Driver** – This software is provided on the Imaging OMNI CD, which is shipped with the board. You must install this device driver to use a DT3145 board with any of the supported software packages or utilities. Refer to [Chapter 2 starting on page 7](#) for information on installing the DT3145 device driver.
- **DT-Active Camera Link Frame Grabber Control** – Use this ActiveX control, provided on the Imaging OMNI CD, if you want to develop your own application software for the DT3145 board using Microsoft Visual Basic or Visual C++ in Windows 2000 or Windows XP. Refer to [Chapter 2 starting on page 7](#) for information on installing the DT-Active Camera Link Frame Grabber Control.
- **DT-AcquireCL** – Use this software, provided on the Imaging OMNI CD, to verify the operation of your DT3145 board during startup. Refer to [Chapter 5 starting on page 33](#) for information on using DT-AcquireCL.
- **GLOBAL LAB Image/2** – Order this optional software package if you want to develop scientific applications using object-oriented image processing tools.
- **DT Vision Foundry** – Order this optional software package if you want to develop machine vision applications using object-oriented image processing tools.

Refer to the Data Translation *Product Handbook* for information on additional software packages available for the DT3145 board.

Accessories

1

The following accessories are available for use with the DT3145 frame grabber board:

- **EP327 cable** – An integrated cable assembly (2-meter or 5-meter) that connects the board to your Camera Link camera. You must order this accessory separately.
- **STP15 screw terminal panel** – A screw terminal panel that accepts digital input signals and an external trigger input signal and provides connections for digital output signals and a strobe output signal. You must order this accessory separately.
- **EP337 cable** – A 2-meter cable assembly that is shipped with the STP15 screw terminal panel. It attaches the STP15 screw terminal panel to the J2 connector on the DT3145 board.

Getting Started Procedure

The flow diagram shown in [Figure 1](#) illustrates the steps needed to get started using the DT3145 frame grabber board. This diagram is repeated in each chapter; the shaded area in the diagram shows you where you are in the getting started procedure.

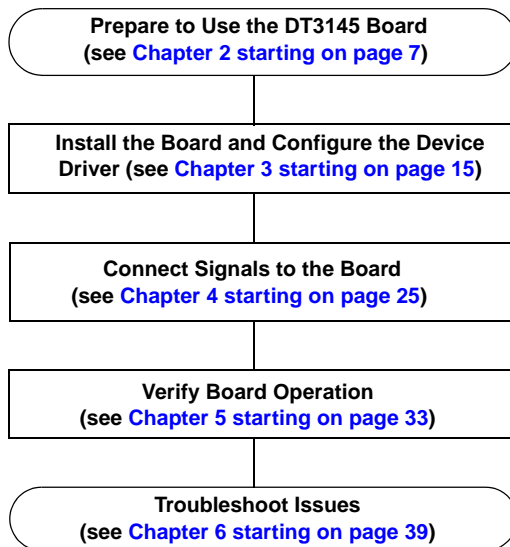
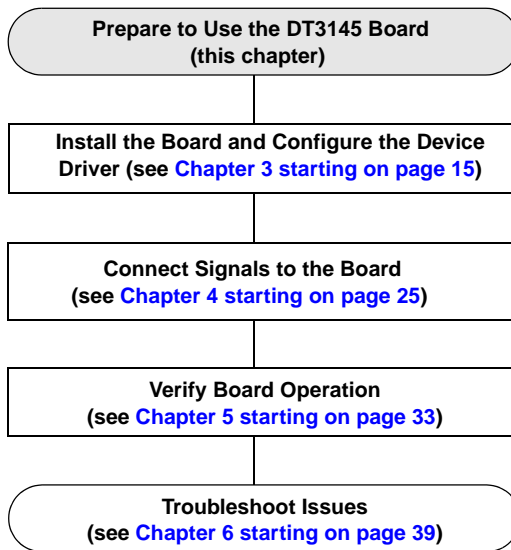

Figure 1: Getting Started Flow Diagram



Preparing to Use the DT3145

Unpacking	9
Checking the System Requirements	10
Installing the Software.....	11
Viewing the DT3145 Documentation	13



Unpacking

Open the shipping box and carefully remove the DT3145 frame grabber board.

2

CAUTION:

Keep the DT3145 board in its protective antistatic bag until you are ready to configure and/or install it.

Verify that the following items are present:

- DT3145 frame grabber board, and
- Imaging OMNI CD.

If an item is missing or damaged, call Data Translation's Customer Service Department at (508) 481-3700 x1394. Customer Service will guide you through the appropriate steps for replacing missing or damaged items. If you are located outside the USA, call your local distributor, listed in your Data Translation *Product Handbook*.

Note: It is recommended that you save the original packing material in the unlikely event that your board requires servicing in the future.

Checking the System Requirements

For reliable operation, your DT3145 frame grabber board requires the following minimum system requirements:

- Pentium III processor
- At least one available PCI 32-bit, 33 MHz bus master expansion slot.
- At least 256 MB of RAM.
- A DirectX-compatible graphics adapter set to 24-bit or 32-bit color.
- At least one CD-ROM drive.
- Window 2000 or Windows XP.
- If you are using the DT-Active Camera Link Frame Grabber Control, Microsoft Visual Basic 6.0 or higher or Microsoft Visual C++ 6.0 or higher.

Installing the Software

To operate properly, the DT3145 frame grabber board requires the following software components, which are provided on the Imaging OMNI CD:

- Microsoft DirectX, version 7.0 or greater,
- DT3145 Device Driver, version 1.0 or greater.

Note: If the DirectX software on your computer is less than version 7.0, you are prompted to install the updated DirectX software from the Imaging OMNI CD.

To install the DT3145-related software from the Imaging OMNI CD, perform the following steps:

1. Insert the Imaging OMNI CD into your CD-ROM drive.
*Typically, the software installation procedure starts automatically. If the installation procedure does not start automatically, click **Run** from the Windows Start menu, either enter `x:\LAUNCH.EXE` (where `x` is the letter of your CD-ROM drive) in the Run dialog box or use the Browse button to locate LAUNCH.EXE, then click **OK**.*
2. From the main screen, click **Install Products**.
3. Click **MACH II SERIES**.
4. Click **Install Devices**.
5. Click **DT3145**.
If you do not have an up-to-date version of DirectX installed on your system, you are prompted to install DirectX software from the Imaging OMNI CD; afterwards, you must repeat steps 1 to 5. If you do have an up-to-date version of DirectX, the InstallShield Wizard appears.
6. Click **Next**.
The license agreement is displayed.

7. Click **Yes** to accept the license agreement, then click **Finish**.
You are prompted to choose your destination location.
8. Click **Next**.
9. Click **Typical** (which installs the driver, ActiveX control, examples, and manuals), **Compact** (which installs only the driver and ActiveX control), or **Custom** (which allows you to select the components to install).
10. Click **Next**.
11. If you selected **Custom**, specify the components that you want to install, then click **Next**. Otherwise, click **Finish**.
12. Click **Main Menu**, then click **Exit**.

Viewing the DT3145 Documentation

Note: To view the DT3145 documentation, Adobe Acrobat 4.0 or greater must be installed on your system. Acrobat Reader 5.0 is provided on the Imaging OMNI CD. If you install Acrobat Reader 5.0 from this CD, make sure that you open Acrobat Reader and accept the license agreement before viewing the documentation.

You can access the DT3145 documentation from the DT3145 program group. From the Windows Start menu, click **Programs | Data Translation, Inc | DT3145**, then select the appropriate document.

You can also access the DT3145 documentation from the Imaging OMNI CD by performing the following steps:

1. Insert the Imaging OMNI CD into your CD-ROM drive.
*Typically, the CD opens automatically. If the CD does not open automatically, click **Run** from the Windows Start menu, either enter **x:\LAUNCH.EXE** (where *x* is the letter of your CD-ROM drive) in the Run dialog box or use the Browse button to locate LAUNCH.EXE, then click **OK**.*
2. From the main screen, click **Install Products**.
3. Click **MACH II SERIES**.
4. Click **Documentation**.
5. Click **Getting Started Manuals**.
6. Click **DT3145**.
7. View and/or print the PDF version of the *DT3145 Getting Started Manual*, then close Adobe Acrobat.
8. Click **Main Menu**.
9. Click **View Documentation**.

10. Click **User's Manuals**.
11. Click **DT3145**.
12. View and/or print the PDF version of the *DT3145 User's Manual*, then close Adobe Acrobat.
13. Click **Main Menu**.
14. Click **View Documentation**.
15. Click **DT-Active Frame Grabber Controls (Mach II)**.
16. View and/or print the PDF version of the *DT-Active Frame Grabber Controls Getting Started Manual*, then close Adobe Acrobat.
17. Click **Main Menu**, then click **Exit**.



Installing the Board and Configuring the Device Driver

Installing the Board	17
Loading and Configuring the Device Driver	23

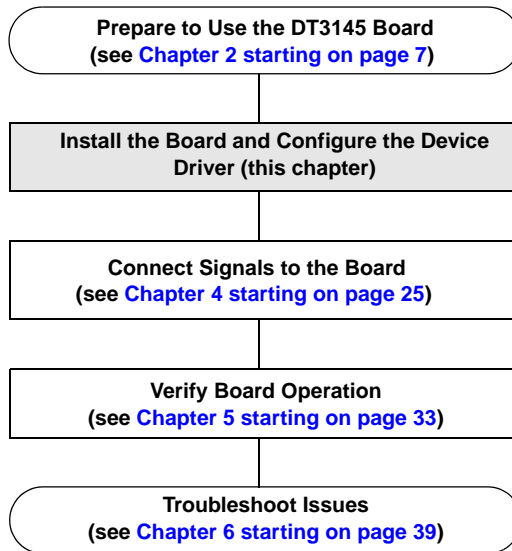

Installing the Board

To install the DT3145 frame grabber board, you must set up the computer, select an expansion slot, configure the trigger selection jumper, if necessary, then insert the board into the computer.

Setting up the Computer

CAUTION:

To prevent electrostatic damage that can occur when handling electronic equipment, use a ground strap or similar device when performing this installation procedure.

3

To set up the computer, perform the following steps:

1. Turn off the computer.
2. Turn off all peripherals (printer, modem, monitor, and so on) connected to the computer.
3. Remove the cover from your computer. Refer to your computer's user manual for instructions.

Next, select an expansion slot, as described in the next section.

Selecting an Expansion Slot

To select an expansion slot, perform the following steps:

1. Select a 32-bit, 33 MHz PCI master expansion slot. Refer to your computer system's user manual to determine which slots are bus masters.

PCI slots are shorter than ISA or EISA slots and are usually white or ivory. Commonly, three PCI slots (one of which may be a shared ISA/PCI slot) are available. If an ISA board is located in a shared slot, you cannot use the slot for a PCI board; likewise, if a PCI board is located in a shared slot, you cannot use the slot for an ISA board.

Note: In most PCI systems, any PCI slot can be a bus master.

2. Remove the cover plate from the selected expansion slot. Retain the screw that held it in place; you will use it later to install the board.

Next, configure the trigger selection jumper, as described in the next section.

Configuring the Trigger Selection Jumper

The DT3145 frame grabber board contains a trigger selection jumper that allows you to specify whether the external trigger input is a common-ground isolated signal or a TTL-level input signal, as follows:

- **Isolated signal** – The trigger input is common-ground isolated and rated for +32 V of isolation. This is the default position of the jumper. Note that the optical isolator adds a delay of approximately 20 μ s to the trigger input.

- **TTL-level signal** – The trigger is a TTL-level signal of 0 to 5 V maximum. This trigger position is useful if your application requires more accurate or faster trigger timing than provided by the isolated signal (for example, if you are using one trigger per line for a line-scan operation).

CAUTION:

The external trigger input accepts a TTL-level signal of 0 to 5 V maximum. To prevent damaging your DT3145 board, make sure that the TTL signal is no greater than 5 V.

3

To configure the trigger selection jumper, if necessary, perform the following steps:

1. Discharge any static electricity by holding the wrapped board in one hand while placing your other hand firmly on a metal portion of the computer chassis.
2. Carefully remove the antistatic packing material from the board. (It is recommended that you save the original packing material in the unlikely event that your board requires servicing in the future.)
3. If you want to use an isolated signal, leave the trigger selection jumper in the default, W1 position.

If you want to use a TTL-level signal, move the trigger selection jumper to the W2 position. Refer to [Figure 2](#).

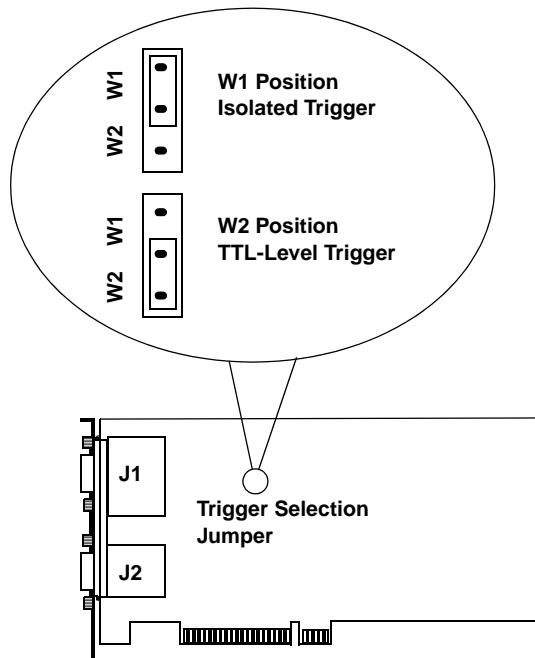

Figure 2: Configuring the Trigger Selection Jumper

Next, insert the DT3145 board in the computer, as described in the next section.

Inserting the DT3145 Board in the Computer

To insert the DT3145 board in the computer, perform the following steps:

1. If necessary, discharge any static electricity by holding the wrapped board in one hand while placing your other hand firmly on a metal portion of the computer chassis.
2. If necessary, carefully remove the antistatic packing material from the board. (It is recommended that you save the original packing material in the unlikely event that your board requires servicing in the future.)
3. Hold the board by its edges and do not touch any of the components on the board.
4. Position the board so that the cable connectors are facing the rear of the computer, as shown in [Figure 3](#).

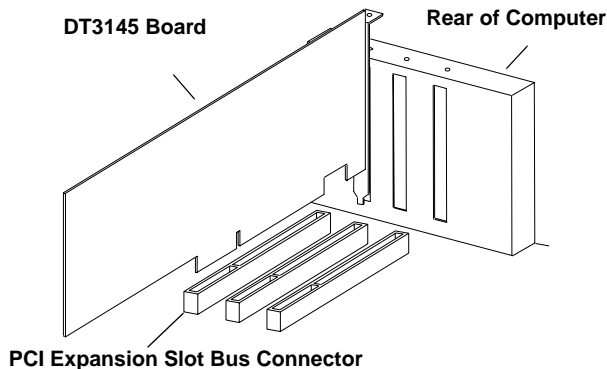

Figure 3: Inserting the DT3145 Board in the Computer

5. Carefully lower the board into the PCI expansion slot using the guide to properly align the board in the slot. When the bottom of the board contacts the bus connector, gently press down on the board until it clicks into place.

CAUTION:

Do not force the board into place. Moving the board from side to side during installation may damage the bus connector. If you encounter resistance when inserting the board, remove the board and try again.

6. Secure the board in place at the rear panel of the computer using the screw removed from the slot cover.
7. Replace the cover and turn on the computer.

When you are finished with this procedure, load and configure the device driver using the instructions in the next section.

Loading and Configuring the Device Driver

If you are using Windows XP, once you install the board and turn the computer on, the New Hardware Found dialog box appears. To load the device driver, select the option to **Install the software automatically (Recommended)**, click **Next**, then click **Finish**.

For Windows 2000, the device driver is automatically loaded when you install the DT3145 software from the Imaging OMNI CD.

Once the driver has been loaded, configure the DT3145 Device Driver by performing the following steps:

1. From the Windows Start menu, select **Settings | Control Panel**.
2. Double-click **DT Imaging Control**.
The DT Image Control dialog box is displayed.
3. Select the DT3145 board to configure.
4. If you wish, change the alias (or name) of the board.
5. If you want to use the board, make sure that the **Disabled** box is not checked.
6. Click **Advanced**.
By default, the installation program automatically points to the directory in which the device configuration files and the LUT files were installed.

7. If you want to change this directory, either enter or browse to the folder from which to load or save the device configuration files and LUT files.

By default, the installation program selects the default.ccf file as the default device configuration file. The settings in the default device configuration file will be applied to the DT-Active Camera Link Frame Grabber control each time you open the control. The default.ccf file assumes that your camera is set up with 1024 x 1024 ROIs, a software trigger, and all camera control output lines used to generate a general-purpose, low-level pulse.

8. If these settings do not match the settings of your camera, select another file to use as the the default device configuration file, then click **OK**.

Note: If you are not sure which device configuration file matches the settings of your camera, you can select any file to use as the default device configuration file, configure the control appropriately, and then save the configuration back to the default device configuration file that you selected. You can also create a new device configuration file and then reconfigure the device driver to use the new file.

9. When you are finished, click **OK**.

When you are finished with this procedure, continue by connecting the Camera Link camera and appropriate signals to the board. Refer to [Chapter 4 starting on page 25](#).



Connecting Signals

Connecting a Camera.	28
Connecting Signals to Connector J2	29

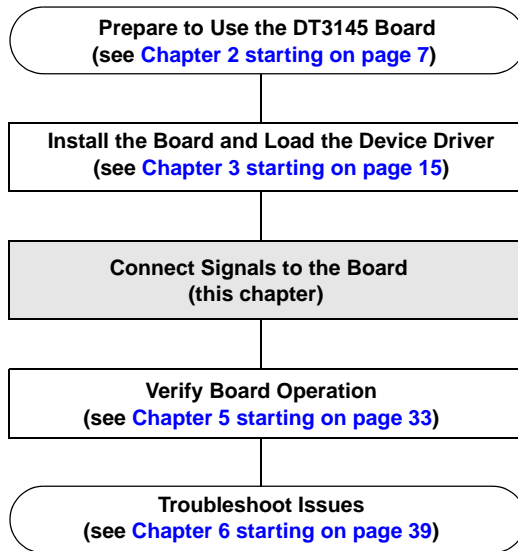

The DT3145 frame grabber board provides two user connectors: J1 and J2. Connector J1 is used to connect the DT3145 board to your Camera Link camera. Connector J2 is used to connect the digital I/O signals, external trigger input signal, strobe output signal, and +5 V output signal.

This chapter describes how to connect camera/signals to the board using the J1 and J2 connectors.

CAUTION:

Always turn off the power to both your computer and your camera before making these connections. Damage can result if connections are made with the power on.

Connecting a Camera

To connect a Camera Link camera to the DT3145 board, perform the following steps:

1. Make sure that power to the computer is off.
2. Push one end of the Camera Link cable (such as the EP327 cable, available from Data Translation) into the J1 connector on the DT3145 board, and tighten the screws on the connector.
3. Push the other end of the Camera Link cable into the connector on your Camera link camera, and tighten the screws on the connector. Refer to [Figure 4](#).

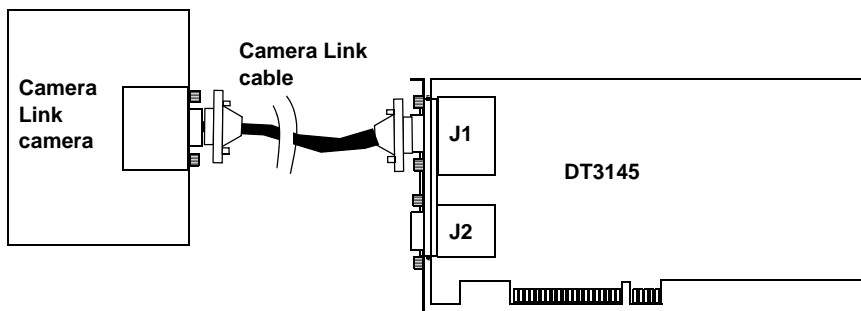

Figure 4: Connecting the Camera to Connector J1

Once you have connected the Camera Link cable to the DT3145 board and camera, connect the appropriate signals to connector J2, as described in the following section.

Connecting Signals to Connector J2

Note: This section assumes that you have purchased an optional STP15 screw terminal panel; the EP337 cable is shipped with the STP15.

To connect digital input, digital output, external trigger input, strobe output, and/or +5 V output signals to connector J2 on the DT3145 board, perform the following steps:

1. Make sure that power to the computer is off.
2. Push one end of the EP337 cable into the J2 connector on the DT3145 board, and tighten the screws on the connector.
3. Push the other end of the EP337 cable into the STP15 screw terminal panel, and tighten the screws on the connector. Refer to [Figure 5](#).

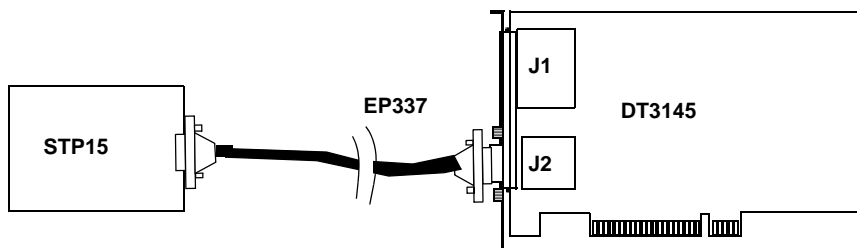

Figure 5: Connecting the STP15 to the DT3145 Board

4. Connect digital input, digital output, external trigger input, strobe output, and/or +5 V output signals to the screw terminals of the STP15. [Figure 6](#) shows the layout of the STP15 and the signal descriptions for each screw terminal.

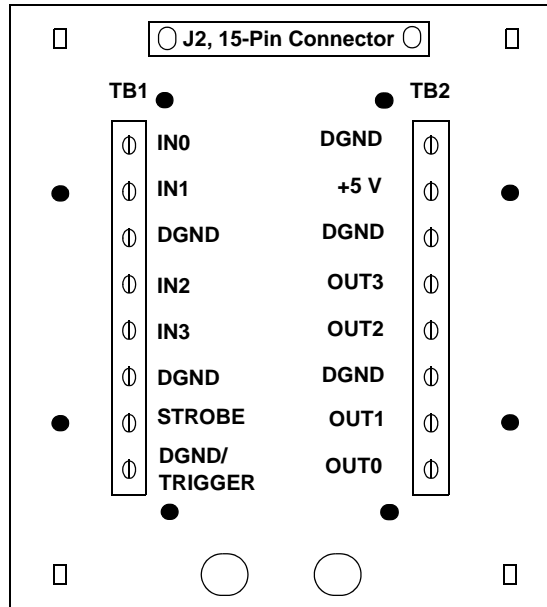

Figure 6: Layout of the STP15 Screw Terminal Panel

Notes: In [Figure 6](#), IN refers to digital input signals, OUT refers to digital output signals, DGND/TRIGGER refers to the external trigger input signal, STROBE refers to the strobe output signal, DGND refers to digital ground signals, and +5 V refers to a +5 V (250 mA) output signal from the DT3145 board.

The dark filled circles in [Figure 6](#) represent holes that you can use to mount the STP15 on a DIN rail. To mount the STP15 on a DIN rail, you need two DIN rail mount adapters (Phoenix Contact part number 1201578 or Data Translation part number 18083), and four thread form screws (Bossard part number BN2724M3x8 or Data Translation part number 18193).

If you are connecting an external trigger input signal, make sure that you have configured the trigger selection jumper to specify whether the trigger input is a common-ground isolated signal or a TTL-level input signal. For more information, refer to [page 18](#).

Once you have connected the appropriate signals to the STP15 screw terminal panel, apply power to the camera and the computer, then verify the operation of the board using the DT-AcquireCL example program. Refer to [Chapter 5 starting on page 33](#).



Verifying Board Operation

Overview	35
Using DT-AcquireCL.....	36

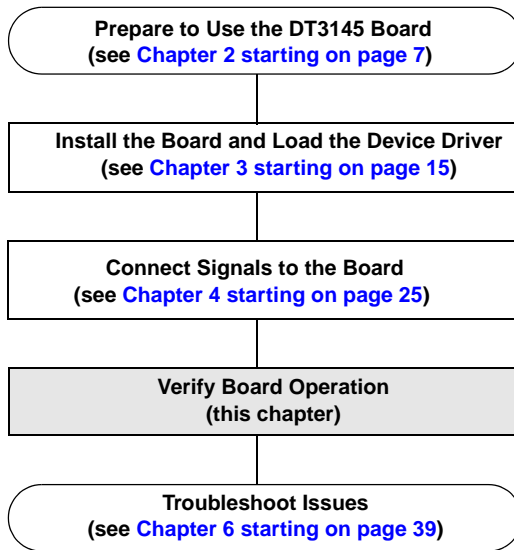

Overview

The DT-AcquireCL example program provides a quick way to verify that your board is properly installed, that the camera is properly connected, and that you can acquire images.

DT-AcquireCL allows you to

- Acquire either a single image or continuous images,
- Open a previously saved .BMP image,
- Save an acquired image in .BMP format,
- Load a device configuration file,
- Save a device configuration file, and
- Perform a digital I/O operation.

DT-AcquireCL is automatically installed when you install the DT3145 software providing that you select either the Typical installation option or the Custom installation option with Example Applications checked (see [page 11](#) for more information).

Using DT-AcquireCL

Note: For more information about DT-AcquireCL, click **Help** from the DT-AcquireCL main menu, then click **DT-AcquireCL Help Topics**.

To use DT-AcquireCL, perform the following steps:

1. Connect a Camera Link camera to the Camera Link connector using a Camera Link cable (such as the EP327 cable, available from Data Translation). Connect digital input, digital output, external trigger input, strobe output, and/or +5 V output signals, as needed, to the STP15 using the EP337 cable. Refer to [Chapter 4 starting on page 25](#) for more information.
2. From the DT-AcquireCL main menu, select **File | Select Device**.
3. From the **Select Device** dialog box, select the alias that you gave to the DT3145 board when you configured the device driver, then click **OK**.
4. Select **Setup | Timeout**, then enter a value to indicate when the acquisition should timeout if a valid video signal is not present.
5. Select **Setup | Configure** to open the Properties dialog box.
6. To use an existing device configuration file, select the Config tab, highlight the file that you want to use, click **Load**, then click **OK**. Click **OK** to close the Properties dialog box, then continue at step 14.

To configure the DT3145 frame grabber board to match the settings of your camera, continue at step 7.

7. Use the Input tab to configure the trigger (used to control the acquisition of ROIs in area-scan mode and the acquisition of lines in line-scan mode) and the frame trigger (if you want to control the acquisition of frames of multiple lines in line-scan mode). When you are finished with this tab, click **Apply** (if changed).
8. Use the Output tab to configure the camera control output lines to generate an expose output signal, an integrate output signal, a strobe output signal, and/or a general-purpose output signal. When you are finished with this tab, click **Apply** (if changed).
9. Use the Capture tab to configure the acquisition type, the area-scan or line-scan properties, and the data format. You can see the effect of these changes by selecting either **Start Continuous** or **Single Acquire**. To stop a continuous acquire operation, select **Stop Continuous**. When you are finished with this tab, click **Apply** (if changed).
10. Use the Digital I/O tab to perform digital I/O operations.
11. Use the LUT tab to select the look-up table to use, then click **Apply** (if changed). By default, LUT 0 uses the identity pattern and LUT 1 uses the inverse pattern. You can see the results of applying the LUT values to the incoming video in the display window.
12. To save the current device configuration to a device configuration file, select the Config tab, then click **Save**. Click **Yes** to save the configuration back to the highlighted file. Click **No** to save the configuration to a new file, then enter the name of the configuration file, the name of the creator of the file (optional), and a short description of the file (optional). When you are finished, click **OK**.
13. When you are finished using the Properties dialog box, click **OK**.

14. From the DT-AcquireCL main menu, select **Run | Start Continuous Acquire** or **Run | Single Frame Acquire**.

Images are acquired and displayed on the screen.

Note that if the image size is larger than the size of the DT-AcquireCL window, you will not see the entire image. To view the entire image, use the Capture tab.

15. To stop a continuous acquire operation, select **Run | Stop Continuous Acquire**.
16. To save an image, if desired, select **File | Save Image File**.
17. When you are finished with this program, select **File | Close Device**, then select **File | Exit** to close the application.



Troubleshooting

General Checklist	41
Service and Support	46
If Your Board Needs Factory Service	49

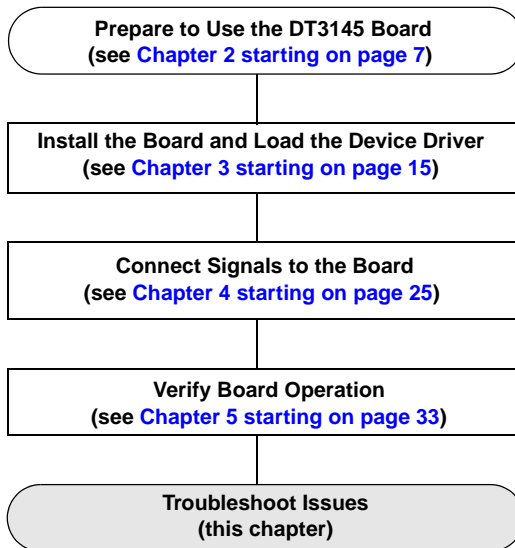

General Checklist

Should you experience problems using the DT3145 frame grabber board, perform the following steps:

1. Read all the documentation provided for your product. Make sure that you have added any “Read This First” information to your manual and that you have used this information.
2. Check the Imaging OMNI CD for any README files and ensure that you have used the latest installation and configuration information available.
3. Check that your system meets the requirements stated on [page 10](#).
4. Check that you have installed the software properly using instructions starting on [page 11](#).
5. Check that you have installed your hardware properly using the instructions starting on [page 17](#).
6. Check that you have loaded and configured the device driver properly using the instructions on [page 23](#).
7. Search the online Knowledgebase in the Support section of the Data Translation web site (at www.datatranslation.com) for an answer to your problem.

If you still experience problems, try using the information in [Table 1](#) to isolate and solve the problem. If you cannot identify the problem, refer to [page 46](#).

Table 1: Troubleshooting Problems

Symptom	Possible Cause	Possible Solution
Board does not respond.	The board is incorrectly aligned in a PCI expansion slot.	Check that the slot in which your DT3145 board is located is a PCI slot and that the board is correctly seated in the slot; see the instructions starting on page 17 .
	The interrupt level is unacceptable.	<p>An interrupt conflict exists in your system. The most common interrupt conflict occurs with a PCI device and a device that is plugged into the ISA bus. To resolve this problem, change the interrupt setting (usually by changing a jumper) on the ISA device.</p> <p>An interrupt conflict can also occur if a PCI device was not designed to share interrupts. To resolve this problem, select a different interrupt for each PCI slot in the PCI BIOS. To do this, enter the system BIOS program; this is usually done by pressing the DEL key when rebooting your system. Once in the system BIOS, enter the PCI/PnP BIOS setup, and select a unique interrupt for each PCI slot. The PCI BIOS assigns the interrupt; the device on the PCI bus does not have control over the interrupt assignment.</p> <p>Some network devices do not share interrupts. If you still have an interrupt conflict, try removing the network device, installing the DT3145 board and rebooting the system, then reinserting the network device.</p>
	The board is damaged.	Contact Data Translation for technical support; refer to page 46 .

Table 1: Troubleshooting Problems (cont.)

Symptom	Possible Cause	Possible Solution
Intermittent operation.	Loose connections or vibrations exist.	Check your wiring and tighten any loose connections or cushion vibration sources; see the instructions in Chapter 4 starting on page 25 .
	Electrical noise exists.	Check your connections; see the instructions in Chapter 4 starting on page 25 .
	The board is overheating.	Check environmental and ambient temperature; consult the board's specifications in Appendix A of the <i>DT3145 User's Manual</i> (UM3145.PDF) and the documentation provided by your computer manufacturer for more information.
Data appears to be invalid.	Wiring is not connected properly.	Check your wiring and fix any open connections; see the instructions in Chapter 4 starting on page 25 .
Computer does not boot.	Board is not seated properly.	Check that the slot in which your DT3145 board is located is a PCI slot, that the board is correctly seated in the slot, and that the board is secured in the slot with a screw; see the instructions on page 17 .
	The power supply of the computer is too small to handle all the system resources.	Check the power requirements of your system resources and, if needed, get a larger power supply; consult the board's specifications in Appendix A of the <i>DT3145 User's Manual</i> (UM3145.PDF).

Table 1: Troubleshooting Problems (cont.)

Symptom	Possible Cause	Possible Solution
System locked up.	Board is not seated properly.	Check that the slot in which your DT3145 board is located is a PCI slot, that the board is correctly seated in the slot, and that the board is secured in the slot with a screw; see the instructions starting on page 17 .
	Interrupt level is unacceptable.	<p>An interrupt conflict exists in your system. The most common interrupt conflict occurs with a PCI device and a device that is plugged into the ISA bus. To resolve this problem, change the interrupt setting (usually by changing a jumper) on the ISA device.</p> <p>An interrupt conflict can also occur if a PCI device was not designed to share interrupts. To resolve this problem, select a different interrupt for each PCI slot in the PCI BIOS. To do this, enter the system BIOS program; this is usually done by pressing the DEL key when rebooting your system. Once in the system BIOS, enter the PCI/PnP BIOS setup, and select a unique interrupt for each PCI slot. The PCI BIOS assigns the interrupt; the device on the PCI bus does not have control over the interrupt assignment.</p> <p>Some network devices do not share interrupts. If you still have an interrupt conflict, try removing the network device, installing the DT3145 board and rebooting the system, then reinserting the network device.</p>

Table 1: Troubleshooting Problems (cont.)

Symptom	Possible Cause	Possible Solution
Images are scrambled.	The capture properties are not set appropriately.	Refer to the documentation for your camera and set the capture properties to match the requirements of your camera. Refer to the <i>DT3145 User's Manual</i> (UM3145.PDF) and to the FGXCL.HLP file on the Imaging OMNI CD for more information.
Acquisition operation timed out.	The capture properties are not set appropriately.	Refer to the documentation for your camera and set the capture properties to match the requirements of your camera. Refer to the <i>DT3145 User's Manual</i> (UM3145.PDF) and to the FGXCL.HLP file on the Imaging OMNI CD for more information.
	Wiring is not connected properly.	Check your wiring and fix any open connections; see the instructions in Chapter 4 starting on page 25 .

Service and Support

If you have difficulty using the DT3145 frame grabber board, Data Translation's Technical Support Department is available to provide technical assistance.

Telephone Technical Support

For the most efficient service, complete the form on [page 47](#) and be at your computer when you call for technical support. This information helps to identify specific system and configuration-related problems and to replicate the problem in house, if necessary.

You can reach the Technical Support Department by calling (508) 481-3700 x1001.

If you are located outside the USA, call your local distributor. The name and telephone number of your nearest distributor are provided in your Data Translation catalog.

If you are leaving a message to request a support call, include the following information:

- Your name (include proper spelling),
- Your company or organization (include proper spelling),
- A phone number,
- An e-mail address where you can be reached,
- The hardware/software product you need help on,
- A summary of the issue or question you have,
- Your contract number, if applicable, and
- Your product serial number or purchase date.

Omitting any of the above information may delay our ability to resolve your issue.

Information Required for Technical Support

Name: _____ Phone _____

Contract Number: _____

Address: _____

Data Translation hardware product(s): _____

serial number: _____

configuration: _____

Data Translation device driver - SPO number: _____

version: _____

Data Translation software - SPO number: _____

serial number: _____ version: _____

PC make/model: _____

operating system: _____ version: _____

Windows version: _____

processor: _____ speed: _____

RAM: _____ hard disk space: _____

network/number of users: _____ disk cache: _____

graphics adapter: _____ data bus: _____

I have the following boards and applications installed in my system: _____

I am encountering the following problem(s): _____

and have received the following error messages/codes: _____

I have run the board diagnostics with the following results: _____

You can reproduce the problem by performing these steps:

1. _____

2. _____

3. _____

E-Mail and Fax Support

You can also get technical support by e-mailing or faxing the Technical Support Department:

- **E-mail:** You can reach Technical Support at the following address: tsupport@datx.com

Ensure that you provide the following minimum information:

- Your name,
- Your company or organization,
- A phone number,
- An e-mail address where you can be reached,
- The hardware/software product you need help on,
- A summary of the issue you are experiencing,
- Your contract number, if applicable, and
- Your product serial number or purchase date.

Omitting any of the above information may delay our ability to resolve your issue.

- **Fax:** Photocopy and complete the form on [page 47](#), then fax Technical Support at the following number: (508) 481-8620.

World-Wide Web

For the latest tips, software fixes, and other product information, you can always access our World-Wide Web site at the following address: <http://www.datatranslation.com>

If Your Board Needs Factory Service

If your board must be returned to Data Translation, perform the following steps:

1. Record the board's serial number, then contact the Customer Service Department at (508) 481-3700 (if you are in the USA) and obtain a Return Material Authorization (RMA).

If you are located outside the USA, call your local distributor for authorization and shipping instructions. The name and telephone number of your nearest distributor are listed in your Data Translation catalog.

All return shipments to Data Translation must be marked with the correct RMA number to ensure proper processing.

2. Using the original packing materials, if available, package the board as follows:
 - Wrap the board in an electrically conductive plastic material. Handle with ground protection. A static discharge can destroy components on the board.
 - Place in a secure shipping container.
3. Return the board to the following address, making sure the RMA number is visible on the outside of the box.

Customer Service Dept.
Data Translation, Inc.
100 Locke Drive
Marlboro, MA 01752-1192

Index

A

accessories
 EP327 cable [5](#)
 EP337 cable [5](#), [29](#)
 STP15 screw terminal panel [5](#)
ActiveX control [4](#)
Adobe Acrobat Reader, using [13](#)

C

cables
 EP327 [5](#)
 EP337 [5](#), [29](#)
checking system requirements [10](#)
connecting camera (to connector J1) [28](#)
connecting signals
 to connector J2 [29](#)
 using the EP337 cable [29](#)
 using the STP15 [29](#)
conventions used [vi](#)
customer service [49](#)

D

DT Vision Foundry [4](#)
DT3145 Device Driver [4](#)
DT3145 documentation, installing [13](#)
DT-AcquireCL [4](#), [36](#)
DT-Active Camera Link Frame
 Grabber Control [4](#)

E

e-mail support [48](#)
EP327 cable [5](#)
EP337 cable [5](#), [29](#)
expansion slot [10](#)
 selection [18](#)

F

factory service [49](#)
fax support [48](#)

G

GLOBAL LAB Image/2 [4](#)

H

help [41](#)

I

inserting the board in the computer [21](#)
installing the DT3145 documentation
 [13](#)
installing the software [11](#)

J

J1 connector [28](#)
J2 connector [29](#)

R

related documents [vi](#)
requirements [10](#)
returning boards to the factory [49](#)
RMA [49](#)

S

screw terminal panel layout [30](#)
selecting an expansion slot [18](#)
service and support procedure [46](#)
setting up the computer [17](#)
slot selection [18](#)
software supported [4](#)
STP15 screw terminal panel [5](#), [29](#)
support
 e-mail [48](#)
 fax [48](#)
 telephone [46](#)
 World Wide Web [48](#)
system requirements [10](#)

T

technical support [46](#)
 e-mail [48](#)
 fax [48](#)
 telephone [46](#)
 World-Wide Web [48](#)
telephone support [46](#)
troubleshooting
 procedure [41](#)
 service and support procedure [46](#)
 troubleshooting table [42](#)

U

unpacking the board [9](#)

V

verifying board operation [35](#)

W

World-Wide Web [48](#)