

DT9820 Series

Ultra-High Resolution USB Module.
Isolated 24-Bit at 7.5 Hz to 16-Bit at 960 Hz,
Simultaneous Acquisition of up to Four
Channels All Powered on USB.

Key Features

- Four separate 24-bit A/D converters.
- Time base independent channels.
- Variable resolution is set based on sample rate.
- 16-bit analog output (DT9822).
- 16 Digital TTL input/output signals (8 in and 8 out).
- External start/stop control lines for each A/D converter.
- Simultaneous subsystem supported to write/read from all subsystems independently.
- True plug-and-play:
 - One cable supplies both power and all connections to the USB module.
 - All connections are external so you do not need to open the PC chassis for installation.
- Hot-swapping capability lets you plug and unplug while your PC is on; no rebooting is required.
- 500 V isolation prevents ground loops and protects your computer.
- Fully compatible with USB 2.0 and 1.1.
- Supported by DT Measure Foundry, test and measurement application builder software that lets you easily create complex measurement applications.
- Ships with DT-Open Layers for .NET Class Library, ready-to-run applications, DT Measure Foundry evaluation, and much more.

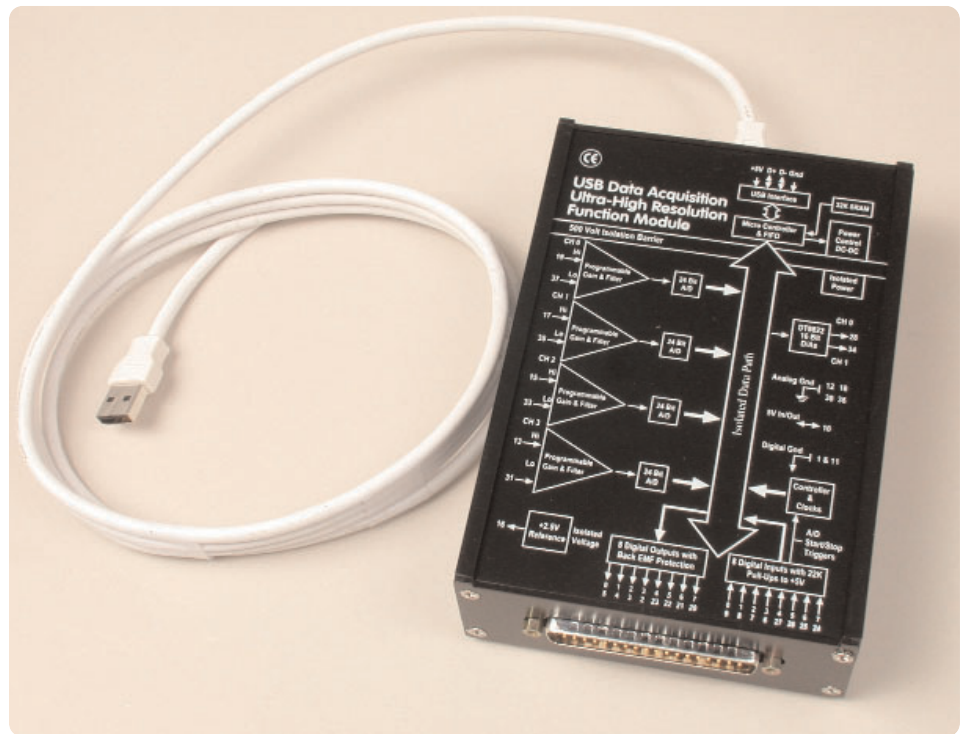

The DT9820 Series is a family of ultra-high resolution USB function modules, featuring four independent 24-bit A/D channels that can measure extremely tiny signals to 60ppb while protected against unwanted voltage levels of more than 500V.

Overview

The DT9820 Series modules are multifunction ultra-high resolution data acquisition modules for the Universal Serial Bus. The Series offers four 24-bit A/D converters for applications that require the highest level of accuracy. The channels are able to start/stop independently of each other, allowing individual channels to be added or removed from the scan list while the ADC is running to support industry standard time base independence.

24-Bit Resolution Separates Minute Traces

The boards can electronically resolve 1 part in 16,777,216 (at 24 bits; equivalent to 60 ppb, or 0.13µV-s) from your transducers. Resolution is variable on each integrator, letting you sample at a higher speed where less resolution is needed — from 7.5 samples per second at 24 bits to 960 samples per second at 16 (1 part in 65,536).

Features Summary

Product Name	Analog Inputs	Input Resolutions	Sample* Rate	Analog Outputs	Output Speed	Output Resolution	Digital I/O (TTL)
DT9821	4 Independent DI	24-bit Variable	6.25 S/s - 960 S/s	-	-	-	8/8
DT9822	4 Independent DI	24-bit Variable	6.25 S/s - 960 S/s	2	1 kHz**	16	8/8

* Throughput is related to resolution.

** System dependent.

Analog Inputs

The DT9820 Series has 4 simultaneous independent differential inputs that can run at a sampling range of 6.25 S/s to 960 S/s based on resolution. Software selectable gain settings of 1, 2, 4, 8, 16, 32 and 64 are available, resulting in bipolar input ranges of +/- 2.5, 1.25, .625, .3125, .15625, .078125, and .039062 volts, input ranges of 0+/-2.5, 1.25, .625, .15625, .078125, .0390625 volts, and an offset unipolar custom input range (see the analog input specifications). The custom input range can be useful for some chromatography application. The analog input subsection features software calibration for pot-less operation.

Time Based Independence

The DT9820 Series allows for independent channel acquisition with up to four input channels. You can start a "run" at any time you want, regardless of the other channels' operations. You arm the channel in software and start the "run" via a hardware switch (trigger). A typical run might have channel 1, 2, and 3 set to take 50 samples/s for 10 minutes. While this is running, another user can set up the fourth channel to do a twenty-five minute run and start that at anytime via a hardware switch enable. At the same time, the software has access to all the data that has been collected.

500 V Isolation Protects Your Data

Because they reside outside the computer, USB modules are susceptible to groundspikes. These spikes can cause system crashes and may even cause permanent damage to your computer. The DT9820 Series features 500 V optical and galvanic isolation that protects your computer from groundspikes and ensures a reliable stream of data.

Acquisition Modes

DT9820 Series modules can acquire a single value from any channel or a number of samples from multiple channels. To acquire data from multiple channels, DT9820 Series modules provide two scan modes: continuously paced and

triggered scan mode. Using continuously paced mode, the board scans the channel-gain list continuously and acquires data until you stop the operation or until a specific number of samples is acquired.

Trigger Inputs and Modes

Internal Triggers:

- Software Trigger
- Triggered Scan Counter

External Trigger:

- External TTL Trigger Input — each channel (independent start) has four separate hardware start trigger inputs and four separate hardware stop trigger inputs.

Clocking

The analog input section uses an internal clock. The internal clock runs in a range from 6.25 Hz to 960 Hz (see chart). If slower rates are desired you can use the Windows timer or do single value operations.

Analog Outputs

The DT9822 module features two DC-level analog outputs. The analog outputs can be updated through programmed I/O (actual speed is dependent on the computer). The resolution is 16 bits with ± 5 V range.

Digital I/O

All DT9820 Series modules feature 16 digital I/O lines. These lines are divided into the following 8-bit ports:

- Port A, input
- Port B, output

The digital outputs have sufficient current capability to drive external solid-state relay modules (sink 12 mA and source 1 mA).

Input Filter

A software-configurable single-pole RC filter is available on any or all four inputs. (200 Hz cut off for 30 db down at 60 Hz).

User Connections

All I/O is brought out to a standard 37 pin connector to be connected to a STP9820. A single USB cable, shipped with each DT9820 Series module, provides both power and connections from your PC. No external power or battery is required.

USB 2.0 Compatibility

The DT9820 Series is fully compatible with USB 2.0 and USB 1.1. USB 2.0 is both forward and backward compatible with USB 1.1, resulting in a seamless transition process for the user. In fact, USB 2.0 uses the same cables and connectors as USB 1.1.

Expansion Capabilities

The DT9820 Series modules are expandable by using additional USB ports.

Cross-Series Compatibility Saves Programming Time, Protects Your Investment

Virtually all Data Translation data acquisition boards, including the DT9820 Series, are compatible with the DT-Open Layers for .NET Class Library software standard. This means that if your application was developed with one of Data Translation's software products, you can easily upgrade to a new Data Translation board, now or in the future. Little or no reprogramming is needed.

DT9820 Series User's Manual

This manual is provided in electronic (PDF) format on the CD-ROM provided with the board. You can also purchase a hard copy of this manual.

DIN-RAIL Mounting Kit for USB

This kit provides a simple, standard-method for mounting equipment to walls, cabinets, or machinery. The kit contains everything you need to fit it directly on the back of the USB function module housing.

Technical Support

As you develop your application, technical support is available when you need it. Extensive information is available 24 hours a day on our web site at www.datatranslation.com, including drivers, example code, pinouts, a searchable KnowledgeBase, and much more.

Support is also available from your point of purchase. You can also request complimentary support via e-mail or fax any time.

J2 37 Pin IO Connector

Pin	Description	Pin	Description
1	Isolated Digital Ground	20	Digital Out 7
2	Digital Out 3	21	Digital Out 6
3	Digital Out 2	22	Digital Out 5
4	Digital Out 1	23	Digital Out 4
5	Digital Out 0	24	Digital In 7
6	Digital In 3	25	Digital In 6
7	Digital In 2	26	Digital In 5
8	Digital In 1	27	Digital In 4
9	Digital In 0	28	Analog Output 0
10	+5 Volts Isolated In / Out	29	Isolated Analog Common
11	Isolated Digital Ground	30	Isolated Analog Common
12	Isolated Analog Common	31	Analog In 03 Return
13	Analog In 03	32	Isolated Analog Common
14	Isolated Analog Common	33	Analog In 02 Return
15	Analog In 02	34	Analog Output 1
16	+2.5 V Reference	35	Analog In 01 Return
17	Analog In 01	36	Isolated Analog Common
18	Isolated Analog Common	37	Analog In 00 Return
19	Analog In 00		

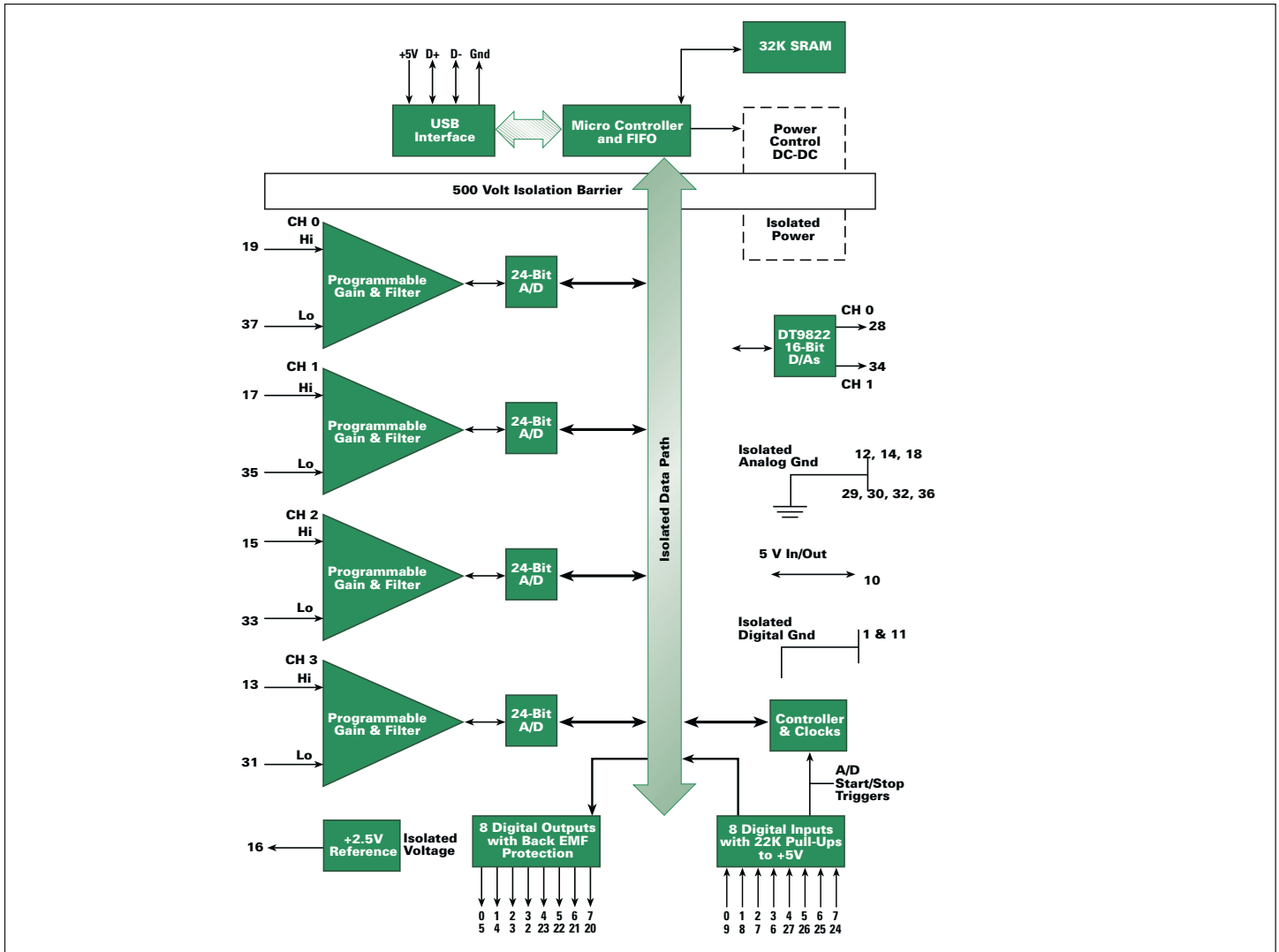

DT9821-22 Block Diagram

Analog Inputs

DT9821/DT9822	
Number of analog input channels	
Differential:	4
Resolution	24 bits
Channel-gain list	4 independent channels/gain
Input FIFO size	512 samples
Input gains	1, 2, 4, 8, 16, 32, and 64
Input range	
Bipolar:	$\pm 0.0390625, \pm 0.078125, \pm 0.15625, \pm 0.3125, \pm 0.625, \pm 1.25, \pm 2.50$ V
Input range	
Unipolar:	0 to 0.0390625, 0 to 0.078125, 0 to 0.15625, 0 to 0.3125, 0 to 0.625, 0 to 1.25, 0 to 2.50 V
Input range	
Offset Unipolar:	-0.015625 to 0.0390625, -0.03125 to 0.078125, -0.0625 to 0.15625, -0.125 to 0.3125, -0.25 to 0.625, -0.50 to 1.25, -1 to 2.50 V
Drift	
Zero Drift:	± 100 nV + (± 5 nV *Gain)/°C
Gain Drift:	± 30 ppm/°C
Input impedance	>100 M Ohm, 3.0 K in Series with 4,700 pF
Input bias current	± 10 nA
Common mode voltage	± 3 V maximum (operational)
Maximum input voltage	± 40 V maximum (protection)
Common mode rejection	>72 db
DC Accuracy	
Nonlinearity (integral)	± 1.0 LSB
Differential nonlinearity	± 0.5 LSB (no missing codes)
A/D converter noise typ.	1.0 LSB rms
Channel-to-channel offset	± 200 μ V
AC Accuracy	
Total harmonic distortion (THD)	-120 dB typical
Channel crosstalk	-120 dB @ 1 kHz
Clocking and trigger input	
Maximum A/D pacer clock	
Single analog input throughput	960 Hz
Multiple analog input throughput	960 Hz
Maximum frequency (analog inputs):	960 Hz per A/D subsystem (4 subsystems)
External digital (TTL) trigger	
High-level input voltage:	2.4 V minimum
Low-level input voltage:	0.8 V maximum
Minimum pulse width:	600 ns (high); 600 ns (low)
Software selectable oscillator operation. Internal Oscillators for A/D 4.9152 MHz 60 Hz Operation	

A/D sample rates (A/Ds must use the same oscillator)

Word Rate (60 Hz)	Word Rate (50 Hz)	Noise Free Resolution*
Oscillator 4.9152 MHz	Oscillator 4.0960 MHz	
960 Hz	800 Hz	16.5
480 Hz	400 Hz	17.0
240 Hz	200 Hz	17.5
120 Hz	100 Hz	20.9
60 Hz	50 Hz	21.4
30 Hz	25 Hz	21.9
15 Hz	12.5 Hz	22.4
7.5 Hz	6.25 Hz	22.9

* 24 bits resolution at all rates

Analog Outputs

DT9822	
Number of analog output channels	2 (voltage output)
Resolution	16 bits
Output range	± 5 V
Output speed	1 kHz (system dependent)
Error	
Gain:	± 6 LSB + Reference
Zero:	Software adjustable to 0
Current output	± 2.5 mA minimum
Output impedance	0.3 Ohm typical
Capacitive drive capability	0.001 μ F (no oscillators)
Nonlinearity (integral)	± 4 LSB
Differential linearity	± 1 LSB (monotonic)
Protection	Short circuit to Analog Common
Power-on voltage	0 V \pm 10 mV maximum
Settling time to 0.01% of FSR	50 μ s, 10 V step; 10.0 μ s, 100 mV step
Slew rate	2 V/ μ s

Options for Software Development

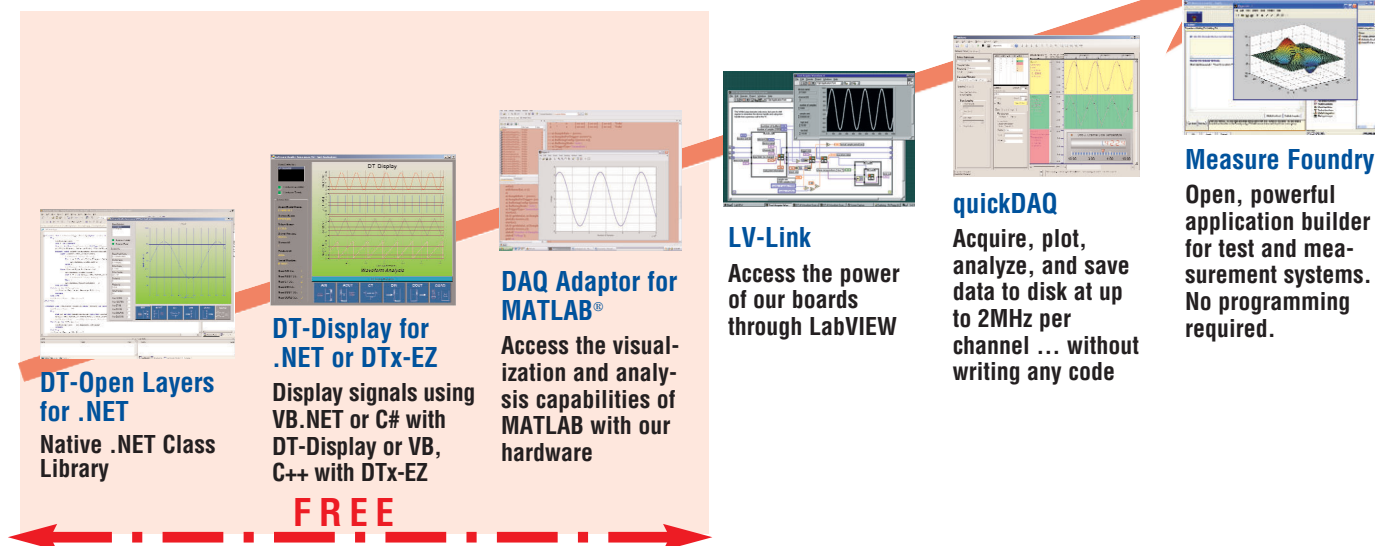

Figure 18. There are many software choices available for application development. Each option offers development capability at different levels. Choose from ready-to-measure applications to full graphical programming with Measure Foundry.

Software

All boards ship with the Omni CD that includes the following software:

■ DT-Open Layers for .NET with DT-Display:

The DT-Open Layers for .NET Class Library is a collection of classes, methods, properties, and events that provides a programming interface for DT-Open Layers-compatible hardware devices. It can be used from any language that conforms to the Common Language Specification (CLS), including Visual Basic.NET, Visual C#, Visual C++.NET with managed extensions, and Visual J#.NET.

— **DT-Display for .NET** is a control for plotting data to a Windows form. It provides a powerful and user-friendly interface for rendering data.

■ DT-Open Layers for Win32:

DT-Open Layers for Win32 consists of the DataAcq SDK and DTx-EZ.

- The **DataAcq SDK** consists of the necessary header files, libraries, example programs, and documentation to develop your own DT-Open Layers data acquisition and control applications. It is intended for use with non .NET languages, such as ANSI C, Visual C++ 6.0, and Visual Basic 6.0.
- **DTx-EZ** provides visual programming tools for Microsoft Visual Basic and Visual C++ that enable quick and easy development of test and measurement applications.

Note: If you have an existing application that was written using the DataAcq SDK, we recommend that you migrate your application to use the DT-Open Layers for .NET Class Library. This will guarantee compatibility with future Data Translation hardware and software.

■ Drivers:

The 32-bit WDM device drivers make your application cross-platform compatible. These drivers support Data Translation USB and PCI boards using Windows 2000/XP.

You can choose to install demo versions of the following software from the CD:

- **Measure Foundry** is an open, powerful application builder for test and measurement systems. No programming is required!
- **quickDAQ** is a high performance, ready-to-run application that lets you acquire, plot, analyze, and save data to disc at 2MHz per channel without writing any code. quickDAQ supports applications from temperature measurement to high-speed testing and analysis.
- **LV-Link** contains all necessary VIs, examples, and documentation to use Data Translation hardware in LabVIEW 8.0 and greater.

The following software is available as a free download from our web site.

- **DAQ Adaptor for MATLAB** to access the visualization and analysis capabilities of MATLAB from The MathWorks™.

Digital I/O

	Port A	Port B	Dynamic Digital Output
Number of lines	8 input	8 output	8 output
Inputs			
High-level input voltage:	2.0 V minimum		
Low-level input voltage:	0.8 V maximum		
High-level input current:	3 μ A		
Low-level input current:	-3 μ A		
Outputs			
Output driver high voltage:			74HCT244(TTL) 2.4 V minimum (IOH = 1 mA);
Output driver low voltage:			0.5 V maximum (IOL = 2 mA)

Power, Physical, and Environmental Specifications



Power (provided by the USB cable)

+5 V standby	0.5 mA maximum
+5 V enumeration	100 mA maximum
+5 V power on	500 mA maximum
+5 V isolated power out (TB 27)	10 mA maximum

Physical

Enclosure:	Extruded aluminum case
Dimension:	145 mm X 100 mm
Weight:	9 oz. (255 grams)
I/O connector:	USB

Certification and compliance

FCC Part 15 Class A verified; will not compromise FCC compliance of host computer CE

Environmental

Operating temperature range:	0°C to 55°C
Storage temperature range:	-25°C to 85°C
Relative humidity:	To 95%, noncondensing

DT9820 Series User's Manuals

A getting started and user's manual are provided in electronic (PDF) format on the CD-ROM provided with the module. You can also purchase a hard copy of these manuals, if you wish.

DIN-RAIL Mounting Kit for USB

This kit provides a simple, standard method for mounting equipment to walls, cabinets, or machinery. The kit contains everything you need to fit it directly on the back of the USB function module housing.

Technical Support

As you develop your application, technical support is available when you need it. Extensive information is available 24 hours a day on our web site at www.datatranslation.com, including drivers, example code, pinouts, a searchable KnowledgeBase, and much more.

Support is also available from your point of purchase. You can also request complimentary support via e-mail or fax at any time.

Ordering Summary

All Data Translation hardware products are covered by a 1-year warranty. For pricing information, see a current price list, visit our web site, or contact your local reseller.

DT9820 Series

Each DT9820 Series module is shipped with the Data Acquisition Omni CD, which includes DT-Open Layers-compliant drivers for Microsoft Windows 2000/XP, ready-to-run software, and comprehensive user's manuals in PDF format. Manuals are available in hard-copy form for an additional charge.

- DT9821 USB function module with 4, 24-bit, 6.25-960 S/s analog inputs, and no analog outputs
- DT9822 USB function module with 4, 24-bit, 6.25-960 S/s analog inputs, and 2, 16-bit analog outputs)

Software

The following software can be purchased separately:

- Measure Foundry is an open, powerful application builder for test and measurement systems.
SP1300-CD
- quickDAQ is a high-performance, ready-to-run application that lets you acquire, plot analyze, and save data to disk at up to 2 MHz per channel.
SP8501-CD
- LV Link to access the power of our boards through LabVIEW.
SP0811

Data Translation now offers free downloads on the Web for:

- DAQ Adaptor for MATLAB to access the analysis and visualization tools in MATLAB.

© Copyright 2006 Data Translation, Inc. All rights reserved. All trademarks are the property of their respective holders. Prices and specifications subject to change without notice. 03/2007