

DATA TRANSLATION

UM-23652-D

***User's Manual
for LXI Measurement
Instruments***

***(TEMPpoint™, VOLTpoint™,
and MEASURpoint™)***

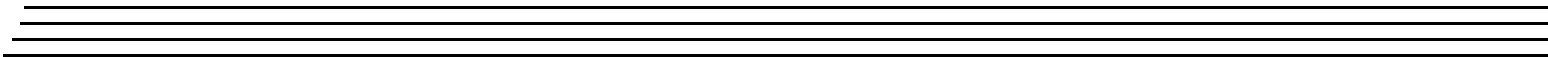
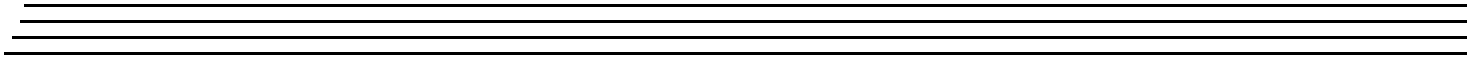
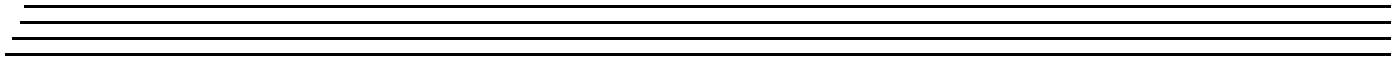

Fourth Edition
May, 2010

Copyright © 2009 - 2010 by Data Translation, Inc.
All rights reserved.

Information furnished by Data Translation, Inc. is believed to be accurate and reliable; however, no responsibility is assumed by Data Translation, Inc. for its use; nor for any infringements of patents or other rights of third parties which may result from its use. No license is granted by implication or otherwise under any patent rights of Data Translation, Inc.

Use, duplication, or disclosure by the United States Government is subject to restrictions as set forth in subparagraph (c)(1)(ii) of the Rights in Technical Data and Computer software clause at 48 C.F.R, 252.227-7013, or in subparagraph (c)(2) of the Commercial Computer Software - Registered Rights clause at 48 C.F.R., 52-227-19 as applicable. Data Translation, Inc., 100 Locke Drive, Marlboro, MA 01752.

Data Translation, Inc.
100 Locke Drive
Marlboro, MA 01752-1192
(508) 481-3700
www.datatranslation.com
Fax: (508) 481-8620
E-mail: info@datx.com

Data Translation® is a registered trademark of Data Translation, Inc. MEASURpoint™, TEMPpoint™, and VOLTpoint™, Measure Foundry™, and ISO-Channel™ are trademarks of Data Translation, Inc.

All other brand and product names are trademarks or registered trademarks of their respective companies.

Radio and Television Interference

This equipment has been tested and found to comply with CISPR EN55022 Class A and EN61000-6-1 requirements and also with the limits for a Class A digital device, pursuant to Part 15 of the FCC Rules. These limits are designed to provide reasonable protection against harmful interference when the equipment is operated in a commercial environment. This equipment generates, uses, and can radiate radio frequency energy and, if not installed and used in accordance with the instruction manual, may cause harmful interference to radio communications. Operation of this equipment in a residential area is likely to cause harmful interference, in which case the user will be required to correct the interference at his own expense.

Changes or modifications to this equipment not expressly approved by Data Translation could void your authority to operate the equipment under Part 15 of the FCC Rules.

Note: This product was verified to meet FCC requirements under test conditions that included use of shielded cables and connectors between system components. It is important that you use shielded cables and connectors to reduce the possibility of causing interference to radio, television, and other electronic devices.

Canadian Department of Communications Statement

This digital apparatus does not exceed the Class A limits for radio noise emissions from digital apparatus set out in the Radio Interference Regulations of the Canadian Department of Communications.

Le présent appareil numérique n'émet pas de bruits radioélectriques dépassant les limites applicables aux appareils numériques de la class A prescrites dans le Règlement sur le brouillage radioélectrique édicté par le Ministère des Communications du Canada.

Table of Contents

About this Manual	11
Intended Audience	11
How this Manual is Organized	12
Conventions Used in this Manual	12
Related Information	13
Where To Get Help	13
Chapter 1: Overview	15
Hardware Features	16
TEMPpoint Features	16
VOLTpoint Features	17
MEASURpoint Features	18
Supported Software	20
Accessories	22
Getting Started Procedure	23
Part 1: Getting Started	25
Chapter 2: Preparing to Use the Instrument	27
Unpacking	29
Checking the System Requirements	30
Installing the Software	31
Prerequisite Software	31
Installing the IVI-COM Driver, Measurement Application, and Eureka Discovery Utility	31
Installing SCPI Support Software	32
Viewing the Documentation	34
Chapter 3: Setting Up and Installing the Instrument	35
Connecting the Instrument to the LAN	37
Connecting to a Site LAN	37
Connecting to a Private LAN	38
Connecting Using a Hub or Switch	38
Connecting Directly to a Computer	39
Applying Power	40
Getting an IP Address and Host Name	42
Determining Ethernet Activity	43
Resetting the Instrument	44

Chapter 4: Wiring Signals	45
General Wiring Recommendations	47
Warm-Up Time	48
Connecting Thermocouple Inputs	49
Connecting RTD Inputs	51
4-Wire RTD Connections	52
3-Wire RTD Connections	52
2-Wire RTD Connections	53
Connecting Voltage Inputs	55
Connecting Voltage Inputs to Thermocouple Channels	55
Connecting Voltage Inputs to RTD Channels	56
Connecting Voltage Inputs to High Voltage Channels	56
Connecting Current Loop Inputs	58
Connecting Current Loop Inputs to Thermocouple Channels	58
Connecting Current Loop Inputs to RTD Channels	59
Connecting Current Loop Inputs to High Voltage Channels	60
Connecting Digital I/O Signals	62
Connecting Digital Input Signals	63
Connecting Digital Output Signals	63
 Chapter 5: Verifying the Operation of Your Instrument	 65
Before Using the Web Interface	67
Java Requirements	67
Internet Explorer Browser Settings	67
JavaScript	68
Security Levels	68
Internet Zone	68
Local Intranet Zone	69
Trusted Sites Zone	70
Pop-up Blockers	70
Associating CSV Files with Microsoft Excel or Notepad	71
Locating Your Instrument on the LAN	72
Running the Eureka Discovery Utility	72
Configuring Windows Firewall Settings	73
Launching the Web Interface	76
Configuring the Instrument	78
LAN Configuration	78
Channel Configuration	79
Scan Rate	80
Filter Configuration	81
Alarm Limits Configuration	82

Digital Input and Trigger Configuration	83
Digital Output Configuration	84
Measuring Data and Controlling the Instrument	85
Starting and Stopping a Scan.	85
Controlling the Digital Outputs	87
Reading the Digital Inputs.	88
Downloading Measurements	89
Part 2: Using Your Instrument	91
Chapter 6: Principles of Operation	93
Block Diagrams	94
DT8871U Block Diagram	94
DT8871 Block Diagram.	95
DT8872 Block Diagram.	96
DT8873 Block Diagram.	97
DT8874 Block Diagram.	98
Analog Input Features	99
Analog Input Channels	99
Thermocouple Input Channels	100
Cold Junction Compensation	101
Open Thermocouple Detection.	101
RTD Channels	102
Input Ranges	102
Out of Range Data for Thermocouple Channels	103
Out of Range Data for RTD Channels	104
Out of Range Data for High Voltage Channels	104
Resolution.	104
Calibration	104
Sample Clock Source	105
Trigger Source	105
Conversion Modes	105
Simultaneous Single-Value Operations	106
Continuous Scan Mode	106
Specifying Analog Input Channels	106
How Continuous Scan Works.	107
Filtering.	107
Data Format	108
Data Format for Thermocouple Channels	108
Data Format for RTD Channels	108
Data Format for High Voltage Channels	108
Error Conditions	108

Digital I/O Features	110
Digital Input Lines	110
Digital Output Lines	111
Channel-to-Channel Isolation	111
Resolution	111
Operation Modes	111
Chapter 7: Troubleshooting	113
General Checklist	114
Technical Support	116
If Your Instrument Needs Factory Service	117
Appendix A: Specifications	119
Basic Instrument Specifications	120
Thermocouple Specifications	121
System Temperature Error for the DT8871U and DT8874	121
System Temperature Error for the DT8871	123
RTD Specifications	125
Isolation and Protection Specifications	126
Memory Specifications	127
Temperature Stability Specifications	128
Voltage Measurement Specifications	129
Digital I/O Specifications	131
Power, Physical, and Environmental Specifications	132
Regulatory Specifications	133
Connector Specifications	134
Thermocouple Connectors	134
RTD Connectors	134
High Voltage Connectors	134
Ethernet (RJ45) Connector	135
Appendix B: Connector Pin Assignments	137
Appendix C: Using the Measurement Application	139
Overview	140
Running the Measurement Application	141
Changing the Configuration of Your Instrument	144
Defining Alarm Limits	146
Logging Data to Disk	148
Viewing a Data File	150
Reading Digital Input Values	151
Exiting from the Measurement Application	152

Appendix D: Configuring Network Settings on Your PC 153
 Configuring the PC to Use Auto-IP 154
 Specifying a Static IP Address for your Instrument 157
 Reconfiguring the PC to Use a Static IP Address 158

Appendix E: About ISO-Channel Technology 159
 ISO-Channel Technology 160
 Why ISO-Channel Technology is Your Best Return on Investment 161
 Understanding Ground Loops 161
 ISO-Channel Eliminates Ground Loops and Increases Common-Mode Rejection . . 162
 Floating, Differential Signals 163
 Simultaneous Architecture 164
 Channel-to-Channel Isolation 165
 Summary 166
 Floating Signal Inputs Offer New Application Advantages 167
 Isolating Each Input 168
 New Application Derived from Isolated Channels 171
 Summary 172

Index 173

About this Manual

TEMPpoint is a family of temperature measurement instruments that includes the DT9871U, DT9871, DT8871U, DT8871, DT9872, and DT8872. This manual describes the DT8871U, DT8871, and DT8872 Ethernet LXI (LAN eXtensions for Instrumentation) models.

VOLTpoint is a family of voltage measurement instruments that includes the DT9873 and DT8873. This manual describes the DT8873 LXI model.

MEASURpoint™ a family of mixed temperature and voltage measurement instruments that includes the DT9874 and DT8874. This manual describes the DT8874 LXI model.

Note: For information on the USB models of TEMPpoint, VOLTpoint, and MEASURpoint, refer to the *User's Manual for USB Measurement Instruments*.

The first part of this manual describes how to install and set up your instrument, and verify that the instrument is working properly.

The second part of this manual describes the features and capabilities of your instrument using the IVI-COM instrument driver software. Troubleshooting information is also provided.

Note: If you are programming the instrument using the IVI-COM driver, refer to the DtxMeasurement IVI-COM driver online help for more information.

If you are using Measure Foundry to program your instrument, refer to the *Measure Foundry User's Manual* and online help for more information.

If you are using Standard Commands for Programmable Instruments (SCPI) to program your instrument, refer to the *SCPI Programmer's Manual for MEASURpoint* for more information.

Intended Audience

This document is intended for engineers, scientists, technicians, or others responsible for using and/or programming a TEMPpoint, VOLTpoint, or MEASURpoint instrument. It is assumed that you have some familiarity with thermocouples, RTDs, and/or voltages and that you understand your application.

How this Manual is Organized

This manual is organized as follows:

- [Chapter 1, “Overview,”](#) summarizes the major features of the TEMPpoint, VOLTpoint, and MEASURpoint instruments, as well as the supported software and accessories.
- [Chapter 2, “Preparing to Use the Instrument,”](#) describes how to unpack the instrument, check the system requirements, install the software, and view the documentation online.
- [Chapter 3, “Setting Up and Installing the Instrument,”](#) describes how to apply power to the instrument and connect the instrument to the network.
- [Chapter 4, “Wiring Signals,”](#) describes how to wire signals to the instrument.
- [Chapter 5, “Verifying the Operation of Your Instrument,”](#) describes how to verify the operation of the instrument with the instrument’s web interface.
- [Chapter 6, “Principles of Operation,”](#) describes the analog input and digital I/O features of the TEMPpoint, VOLTpoint, and MEASURpoint instruments in detail.
- [Chapter 7, “Troubleshooting,”](#) provides information that you can use to resolve problems with your instrument, should they occur.
- [Appendix A, “Specifications,”](#) lists the specifications of the TEMPpoint, VOLTpoint, and MEASURpoint instruments.
- [Appendix B, “Connector Pin Assignments,”](#) describes the pin assignments of the digital I/O connector on the TEMPpoint, VOLTpoint, and MEASURpoint instruments.
- [Appendix C, “Using the Measurement Application,”](#) describes how to use the Measurement Application with a TEMPpoint, VOLTpoint, or MEASURpoint instrument.
- [Appendix D, “Configuring Network Settings on Your PC,”](#) describes how to configure the network settings of your PC to use Auto-IP or a static IP address.
- [Appendix E, “About ISO-Channel Technology,”](#) describes the benefits of ISO-Channel™ technology.
- An index completes this manual.

Conventions Used in this Manual

The following conventions are used in this manual:

- Notes provide useful information or information that requires special emphasis, cautions provide information to help you avoid losing data or damaging your equipment, and warnings provide information to help you avoid catastrophic damage to yourself or your equipment.
- Items that you select or type are shown in **bold**.

Related Information

Refer to the following documents for more information on using a TEMPpoint, VOLTpoint, or MEASURpoint instrument:

- DtxMeasurement IVI-COM Driver online help. For programmers who are developing their own application programs using a tool other than Measure Foundry, this document describes how to use the IVI-COM driver to access the capabilities of your instrument.

The IVI-COM driver works with any development environment that supports COM programming, including MATLAB® from The MathWorks™, Microsoft® Visual C#®.NET or Visual Basic®.NET, Agilent® VEE Pro, National Instruments™ LabVIEW™ or LabWindows™, and so on.

- Measure Foundry manual and online help. For programmers who purchase Measure Foundry to easily create custom applications for a TEMPpoint, VOLTpoint, or MEASURpoint instrument, these documents describe the functions and capabilities of the Measure Foundry software.
- *SCPI Programmer's Manual for LXI Measurement Instruments*. For programmers who want to use the SCPI interface to program a TEMPpoint, VOLTpoint, or MEASURpoint instrument, this document describes the supported SCPI commands and example programs for these instruments.
- IVI foundation (www.ivifoundation.org)
- *Omega Complete Temperature Measurement Handbook and Encyclopedia®* or the Omega Engineering web site: <http://www.omega.com>. Both resources provide valuable information on thermocouple types, RTD types, standards, and linearization.

Where To Get Help

Should you run into problems installing or using a TEMPpoint, VOLTpoint, or MEASURpoint instrument, the Data Translation Technical Support Department is available to provide technical assistance. Refer to [Chapter 7](#) for more information. If you are outside the United States or Canada, call your local distributor, whose number is listed on our web site (www.datatranslation.com).



Overview

Hardware Features.....	16
Supported Software.....	20
Accessories	22
Getting Started Procedure.....	23

Hardware Features

Data Translation provides a number of LXI (Ethernet) instruments to meet your measurement needs, including the following:

- TEMPpoint – a family of temperature measurement instruments
- VOLTpoint – a family of voltage measurement instruments
- MEASURpoint – a family of mixed temperature and voltage measurement instruments

All of these Ethernet instruments are class C devices that comply with LXI version 1.1.

The following sections summarize the features of the TEMPpoint, VOLTpoint, and MEASURpoint LXI instruments.

TEMPpoint Features

TEMPpoint instruments include the following models: DT8871U, DT8871, and DT8872.

The key features of TEMPpoint instruments are as follows:

- *DT8871U and DT8871:*
 - Configurable analog input channels for thermocouple or differential voltage inputs; easy-access jacks for each channel for quick wiring
 - One CJC (cold junction compensation) input for each thermocouple channel
 - B, E, J, K, N, R, S, and T thermocouple types supported; the instrument automatically linearizes the measurements and returns the data as a 32-bit, floating-point temperature values
 - Input range of ± 0.075 V for the DT8871U (with 0.25 μ V RMS A/D noise using no software filtering) and ± 1.25 V for the DT8871 (with 5 μ V RMS A/D noise using no software filtering)
 - Break-detection circuitry to detect open thermocouple inputs
- *DT8872:*
 - Configurable analog input channels for RTDs and differential voltage inputs; easy-access jacks for each channel for quick wiring
 - 100 Ω , 500 Ω , and 1000 Ω platinum RTD types supported using alpha curves of 0.00385 (European) or 0.00392 (American)
 - 4-wire, 3-wire, or 2-wire configurations; the DT8872 automatically linearizes the measurements and returns the data as 32-bit, floating-point temperature, resistance, or voltage values
 - Input range of ± 1.25 V
- One 24-bit, Delta-Sigma A/D converter per channel for simultaneous, high-resolution measurements
- ± 500 V galvanic isolation channel-to-channel and to the host computer to protect signal integrity

- Throughput rate of up to 10 Samples/s for all channels.
- Software or external, digital trigger on digital input line 0 starts acquisition
- Auto-calibrating front-end resets the zero point on each power-up; in addition, the instrument supports anytime calibration, performing an auto-calibration function on software command
- Measurement Instrument Calibration Utility allows you to calibrate the instrument in the field (see [page 21](#) for more information on this utility)
- 8 opto-isolated digital input lines; you can read the digital input port through the analog input data stream for correlating analog and digital measurements
- 8 opto-isolated digital output lines; the outputs are solid-state relays that operate from ± 30 V at currents up to 400 mA (peak) AC or DC

VOLTpoint Features

The key features of VOLTpoint (DT8873) instruments are as follows:

- Direct connection of analog input channels for differential voltage inputs; removable screw terminal blocks for each channel for quick wiring
- One 24-bit, Delta-Sigma A/D converter per channel for simultaneous, high-resolution measurements
- ± 500 V galvanic isolation channel-to-channel and to the host computer to protect signal integrity
- Software-selectable input range of ± 10 V, ± 100 V, or ± 400 V per channel
- Throughput rate of up to 10 Samples/s for all channels
- Software or external, digital trigger on digital input line 0 starts acquisition
- Auto-calibrating front-end resets the zero point on each power-up; in addition, the instrument supports anytime calibration, performing an auto-calibration function on software command
- Measurement Instrument Calibration Utility allows you to calibrate the instrument in the field (see [page 21](#) for more information on this utility)
- 8 opto-isolated digital input lines; you can read the digital input port through the analog input data stream for correlating analog and digital measurements
- 8 opto-isolated digital output lines; the outputs are solid-state relays that operate from ± 30 V at currents up to 400 mA (peak) AC or DC

MEASURpoint Features

The standard MEASURpoint (DT8874) instrument provides 16 thermocouple channels, 16 RTD channels, and 16 high voltage channels.

The key features of MEASURpoint (DT8874) instruments are as follows:

- *Analog Input Channels 0 to 15:*
 - Configurable channels for thermocouple or differential voltage inputs; easy-access jacks for each channel for quick wiring
 - One CJC (cold junction compensation) input for each thermocouple channel
 - B, E, J, K, N, R, S, and T thermocouple types supported; the instrument automatically linearizes the measurements and returns the data as a 32-bit, floating-point temperature values
 - Input range of ± 0.075 V (with 0.25 μ V RMS A/D noise using no software filtering)
 - Break-detection circuitry to detect open thermocouple inputs
- *Analog Input Channels 16 to 31:*
 - Configurable analog input channels for RTDs and differential voltage inputs; easy-access jacks for each channel for quick wiring
 - $100\ \Omega$, $500\ \Omega$, and $1000\ \Omega$ platinum RTD types supported using alpha curves of 0.00385 (European) or 0.00392 (American)
 - 4-wire, 3-wire, or 2-wire configurations; the DT8872 automatically linearizes the measurements and returns the data as 32-bit, floating-point temperature, resistance, or voltage values
 - Input range of ± 1.25 V
- *Analog Input Channels 31 to 48:*
 - Direct connection of analog input channels for differential voltage inputs; removable screw terminal blocks for each channel for quick wiring
 - Software-selectable input range of ± 10 V, ± 100 V, or ± 400 V per channel
- One 24-bit, Delta-Sigma A/D converter per channel for simultaneous, high-resolution measurements
- ± 500 V galvanic isolation channel-to-channel and to the host computer to protect signal integrity
- Throughput rate of up to 10 Samples/s for all channels
- Software or external, digital trigger on digital input line 0 starts acquisition
- Auto-calibrating front-end resets the zero point on each power-up; in addition, the instrument supports anytime calibration, performing an auto-calibration function on software command
- Measurement Instrument Calibration Utility allows you to calibrate the instrument in the field (see [page 21](#) for more information on this utility)

- 8 opto-isolated digital input lines; you can read the digital input port through the analog input data stream for correlating analog and digital measurements
- 8 opto-isolated digital output lines; the outputs are solid-state relays that operate from ± 30 V at currents up to 400 mA (peak) AC or DC

Supported Software

The following software is available for use with the TEMPpoint, VOLTpoint, and MEASURpoint instruments:

- **Eureka Discovery Utility** – This utility helps you locate or "discover" all LXI (Ethernet) instruments that are connected to your system and provides the following information about your instrument: the IP address, manufacturer, model number, serial number, and version of the firmware that is running on your instrument. In addition, you can use this utility to configure Windows firewall settings and update the firmware for your Data Translation LXI instrument.
- **Instrument Web Interface** – This built-in interface, described in [Chapter 5](#), allows you to verify the operation of your instrument and perform basic functions with Internet Explorer and no additional software. Using it, you can configure your instrument, control output signals, measure input signals, and save results to disk.
- **Measurement Application** – This application, developed using Measure Foundry, lets you do the following:
 - Configure your instrument
 - Acquire temperature, voltage, or resistance data from up to 48 analog input channels
 - Display acquired temperature, voltage, or resistance data during acquisition
 - Set alarm limits for each channel
 - Update the value of the digital output lines based on alarm conditions
 - Use a chart recorder to display data over time and log it to an .hpf file for later analysis
 - Open the last recorded .hpf data file in Microsoft Excel
 - View any .hpf data file in a file viewer

You can customize this application to suit your needs using Measure Foundry Professional with the Instrument Pak; the source code for this application is included with the instrument.

- **Measure Foundry** – An evaluation version of this software is available for developing applications for TEMPpoint, VOLTpoint, or MEASURpoint instruments. Measure Foundry is a rapid application development package that provides a system solution for all types of measurement instruments. Using Measure Foundry, you can develop complex test and measurement applications easily without writing code. Simply drag and drop components on a form and configure their property pages to access all elements of your instrument.

Measure Foundry supports all LXI instrument classes through IVI-COM. Instruments with interfaces such as GPIB, PXI/LXI, RS-232, and USB are supported through SCPI commands using the VISA transport layer.

Order the Instrument Pak for Measure Foundry (SP1309-CD) to build your own application for the instrument.

- **DtxMeasurement IVI-COM driver** – This driver provides access to the instrument's functions through a COM server. The IVI-COM driver works in any development environment that supports COM programming, including Measure Foundry, MATLAB, Visual Basic.NET, Visual C#.NET, Agilent VEE Pro, LabVIEW, LabWindows, and others.

- **SCPI commands** – Use SCPI commands to program TEMPpoint, VOLTpoint, or MEASURpoint LXI instruments. Refer to the *SCPI Programmer's Manual for LXI Measurement Instruments* for information on the supported SCPI commands and example programs.
- **Measurement Instrument Calibration Utility** – Users can calibrate a TEMPpoint, VOLTpoint, or MEASURpoint instrument in the field using precise calibration equipment and the Measurement Instrument Calibration Utility. Since each instrument consists of up to 48 individual channels, great care must be taken to ensure that proper warm-up times are followed and precise calibration equipment is used.

The calibration utility ships with a comprehensive help file that describes the required equipment and calibration procedure, including warm-up times, for each instrument.

The calibration utility allows you to revert to the factory calibration for any or all channels, or revert back to the last user calibration values, if desired. In addition, this utility generates a report that lists the starting and ending calibration values for each channel, allowing traceability.

Refer to the Data Translation web site (www.datatranslation.com) for information about selecting the right software package for your needs.

Accessories

The following optional accessories are available for TEMPpoint, VOLTpoint, or MEASURpoint instruments:

- **STP37 screw terminal panel** – The STP37 permits easy screw terminal connections for accessing the digital I/O signals of a TEMPpoint, VOLTpoint, or MEASURpoint instrument.
- **EP333 cable** – The EP333 is a 2-meter shielded cable with two 37-pin connectors that connects the STP37 screw terminal panel to the digital I/O connector of the instrument.
- **Rack-mount kits** – To rack mount a single instrument, order a single rack-mount kit (Data Translation part number 22927).

To rack mount two instruments side by side, order a dual rack-mount kit (Data Translation part number 22735).

Getting Started Procedure

The flow diagram shown in [Figure 1](#) illustrates the steps needed to get started using a TEMPpoint, VOLTpoint, or MEASURpoint instrument. This diagram is repeated in each Getting Started chapter; the shaded area in the diagram shows you where you are in the getting started procedure.

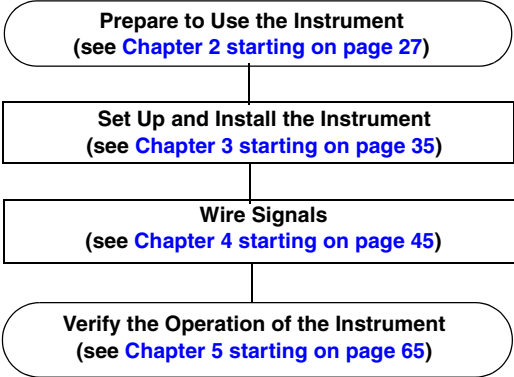

Figure 1: Getting Started Flow Diagram

Part 1: Getting Started



Preparing to Use the Instrument

Unpacking	29
Checking the System Requirements	30
Installing the Software	31
Viewing the Documentation	34

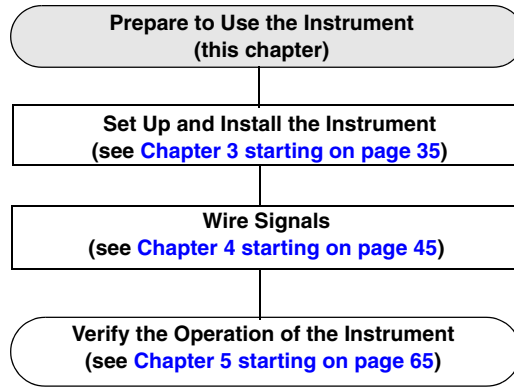

Unpacking

Open the shipping box and verify that the following items are present:

- TEMPpoint, VOLTpoint, or MEASURpoint instrument
- EP372 Ethernet cable
- EP361 +5V power supply and cable
- Instrument OMNI CD-ROM
- For DT8872, DT8874, and DT8874 instruments, a bag of pluggable screw terminable blocks and a screwdriver.

If an item is missing or damaged, contact Data Translation. If you are in the United States, call the Customer Service Department at (508) 481-3700, ext. 1323. An application engineer will guide you through the appropriate steps for replacing missing or damaged items. If you are located outside the United States, call your local distributor, listed on Data Translation's web site (www.datatranslation.com).

Once you have unpacked your instrument, check the system requirements, as described in the next section.

Checking the System Requirements

For reliable operation, the computer that accesses your instrument requires the following configuration:

- PC with Pentium III, 500 MHz (or higher) processor
- Screen resolution of 1024 x 768 (or higher)
- 256 MB of RAM; 512 MB (or more) recommended
- 50 MB of hard disk space
- Ethernet port
- CD-ROM drive
- Administrator privileges for software installation
- For access to the instrument web interface:
 - Java Version 6, Update 5 or greater
 - Internet Explorer 6.0 or 7.0 web browser

Refer to [page 67](#) for more information on installing Java and configuring your browser settings

- Acrobat Reader 5.0 or later for viewing documentation

Once you have verified that your system meets the system requirements, install the software, as described in the next section.

Installing the Software

This section describes how to install the software you need to use your TEMPpoint, VOLTpoint, or MEASURpoint instrument.

Prerequisite Software

No prerequisite software is required if you are using a single client to access a TEMPpoint, VOLTpoint, or MEASURpoint instrument on the LXI bus, or if you are managing how multiple clients concurrently access the instrument on the LXI bus. (In these case, your application can use sockets to communicate with the instrument.)

If, however, you want multiple clients to access your instrument on the LXI bus, and you want to "lock" access to the instrument so that one client cannot change the configuration of the instrument that another client is accessing, you need to install VISA; we recommend either Agilent VISA or NI-VISA from National Instruments. You can then use the VISA methods viLock/viUnlock to prevent other clients from accessing the instrument.

To install Agilent VISA, do the following:

1. Go to www.agilent.com, enter **IO Libraries Suite** in the search field, and select **Agilent IO Libraries Suite 15.0** from the search results.
2. Follow the instructions on Agilent's web site to download and install the Agilent IO Libraries, which include VISA support, VISA COM support, and the Agilent Connection Expert tool.

We recommend that you run Data Translation's Eureka Discovery Utility that is provided with the Measurement software to locate your LXI instrument on the network (see [page 72](#) for more information).

Installing the IVI-COM Driver, Measurement Application, and Eureka Discovery Utility

The Measurement Application, developed using Measure Foundry, provides a quick way to verify that your instrument is working properly. To install the Measurement Application, Eureka Discovery Utility, and all the components necessary to use the Measurement Application with your instrument, including the IVI-COM driver, perform the following steps:

1. Insert the Instrument OMNI CD into your CD-ROM or DVD drive.
The installation program should start automatically, and the Instrument OMNI installation program should appear.
2. If the installation program does not start automatically, double-click **Setup.exe** from the CD.
The installation program appears.
3. Click **Install from Web (recommended)** to get the latest version of the software from the web or **Install from CD** to install the software from the CD.

4. If you are installing from the web, perform these steps:
 - a. Click **Measurement Instrument Software** and follow the prompts to install the software (including the Measurement Application and IVI-COM driver) and related documentation.
 - b. If you wish to install the evaluation version of Measure Foundry, click **Measure Foundry (Evaluation)** from the MEASURpoint Installation web site, and follow the prompts to install the software and related documentation.

Note: To use Measure Foundry with TEMPpoint, VOLTpoint, or MEASURpoint instruments, select the evaluation version of **Measure Foundry Pro + Instruments Pak**.

- c. If you wish to install the Eureka Discovery Utility (recommended), click **Eureka Discovery Utility** from the Measurement Installation web site, and follow the prompts to install the software and help file.
5. If you are installing from the Instrument OMNI CD, perform these steps:
 - a. Click **Install Measurement Software**.
 - b. Ensure that **Measurement (Software & Application)** is selected.
 - c. If you wish to install the evaluation version of Measure Foundry in addition to the Measurement application, also select **Measure Foundry (EVAL)**.

Note: To use Measure Foundry with TEMPpoint, VOLTpoint, and MEASURpoint instruments, select the evaluation version of **Measure Foundry Pro + Instruments Pak**.

- d. If you wish to install the Eureka Discovery Utility (recommended), select **Eureka Discovery Utility**.
 - e. Click **Install Selected Features** and follow the prompts to install the software.
 - f. When you are finished with the Instrument OMNI CD, click **Quit Installer**.

For information on using the Measurement Application to verify the operation of your instrument, refer to [Chapter 5](#) starting on [page 65](#).

Installing SCPI Support Software

If you wish, you can develop application programs for TEMPpoint, VOLTpoint, and MEASURpoint LXI instruments using SCPI (Standard Commands for Programmable Instruments). To install the SCPI example programs and documentation, perform the following steps:

1. If you have not already done so, perform the following steps:
 - a. Insert the Instrument OMNI CD into your CD-ROM or DVD drive.
The installation program should start automatically, and the installation program should appear.
 - b. If the installation program does not start automatically, double-click **Setup.exe** from the CD.
The installation program appears.

- c. Click **Install from Web** or **Install from CD**.
2. If you are installing from the web, click **Measurement Instrument SCPI Support** and follow the prompts to install the example programs and documentation.
3. If you are installing from the Instrument OMNI CD, perform these steps:
 - a. Click **Install Additional Software**.
 - b. Click **Measurement SCPI Support**.
 - c. Click **Install Selected Features** and follow the prompts to install the example programs and documentation.
 - d. When you are finished with the Instrument OMNI CD, click **Quit Installer**.

Viewing the Documentation

Note: To view the documentation, you must have Adobe Reader 5.0 or greater installed on your system. Adobe Reader is provided on the Instrument OMNI CD. If you install Adobe Reader from this CD, make sure that you open Adobe Reader and accept the license agreement before viewing the documentation.

You can access the documentation for your instrument from the Windows Start menu as follows:

- For documentation about the TEMPpoint, VOLTpoint, or MEASURpoint instrument, click **Programs -> Data Translation, Inc -> Hardware Documentation -> Measurement User's Manual for LXI Instruments**.
- For documentation on the DtxMeasurement IVI-COM driver, click **Programs -> IVI -> DtxMeasurement -> Documentation**.
- For documentation on the Eureka Discovery Utility, click **Programs -> Data Translation, Inc -> Instrument Support -> Eureka LXI Instrument Discovery**.
- For documentation about SCPI support, click **Programs -> Data Translation, Inc -> Measurement SCPI Support -> SCPI Programmer's Manual for Measurement**.
- For documentation about Measure Foundry, click **Programs -> Data Translation, Inc -> Measure Foundry -> 5.1**.

The following may be helpful when using Adobe Reader:

- To navigate to a specific section of the document, click a heading from the table of contents on the left side of the document.
- Within the document, click the text shown in blue to jump to the appropriate reference (the pointer changes from a hand to an index finger).
- To go back to the page from which the jump was made, click the right mouse button and **Go Back**, or from the main menu, click **Document**, and then **Go Back**.
- To increase or decrease the size of the displayed document, from the main menu, click **View**, and then **Zoom**.
- By default, Adobe Reader smooths text and monochrome images, sometimes resulting in blurry images. If you wish, you can turn smoothing off by clicking **File**, and then **Preferences/General**, and unchecking **Smooth Text and Images**.



Setting Up and Installing the Instrument

Connecting the Instrument to the LAN	37
Getting an IP Address and Host Name.....	42
Determining Ethernet Activity.....	43
Resetting the Instrument.....	44

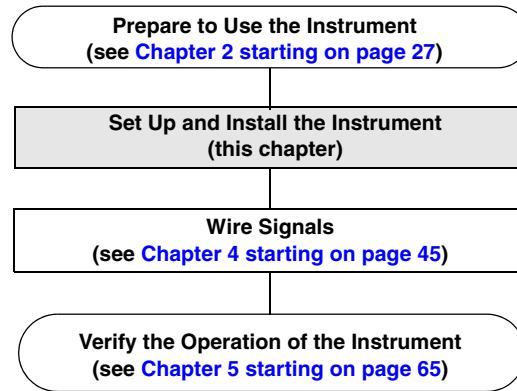

Note: Your TEMPpoint, VOLTpoint, and MEASURpoint instruments are factory-calibrated. Thereafter, yearly recalibration is recommended. Refer to [page 104](#) for more information on calibration.

Connecting the Instrument to the LAN

This section describes how to connect your instrument to the LAN (Local Area Network). Two connection schemes are shown:

- Site LAN connections, described on this page
- Private LAN connections, described on [page 38](#)

Note: It is recommended that you consult with your network administrator to ensure that all network security, performance, and reliability issues are considered when using connecting instruments to the LAN.

Connecting to a Site LAN

A site LAN is useful in applications that require access by many users or access by users at distributed sites. In this connection scheme, a DHCP (Dynamic Host Configuration Protocol) server is used to assign an IP address to the instrument.

[Figure 2](#) shows a typical site LAN connections using a dedicated Ethernet hub, switch, or router. [Figure 3](#) shows typical site LAN connections without using a dedicated Ethernet hub, switch, or router.

Note: Use standard LAN cables for network connections. TEMPpoint, VOLTpoint, and MEASURpoint instruments ship with a standard LAN cable (EP372) for connecting to the LAN (RJ45) connector on the rear panel of the instrument.

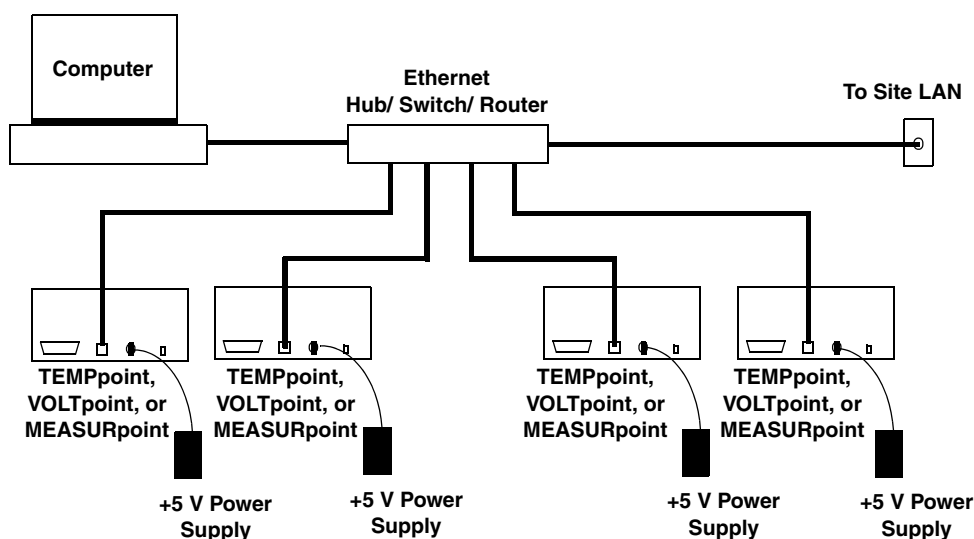

Figure 2: Typical Site LAN Connections using a Hub, Switch, or Router

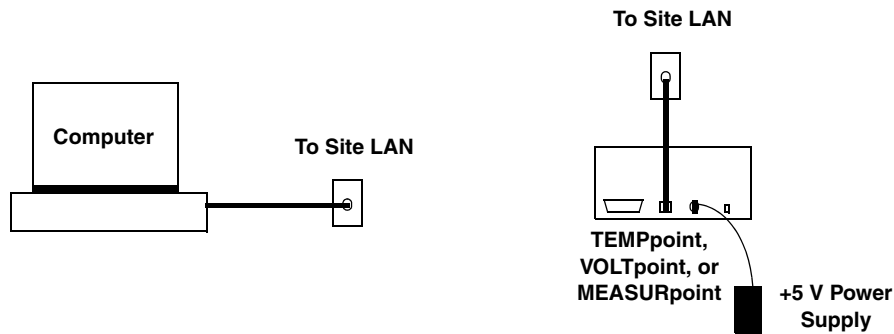

Figure 3: Typical Site LAN Connections Without Using a Hub, Switch, or Router

Connecting to a Private LAN

A private LAN (or subnet) generally involves the direct connection of the instruments to the computer, and may include Ethernet hubs or switches. Access to the instruments is limited to users that are directly connected to the private LAN; therefore, security, performance, and reliability are generally better on a private LAN than on a site LAN.

In this connection scheme, the DHCP (Dynamic Host Configuration Protocol) server is typically not available; therefore, Auto-IP is used to assign an IP address to the instrument.

Note: If no DHCP server exists and your PC is set up to use a static IP address, you must temporarily reconfigure your PC to use Auto-IP, as described on [Appendix D](#) starting on [page 153](#).

Connecting Using a Hub or Switch

[Figure 4](#) shows a typical connection scheme when connecting TEMPpoint, VOLTpoint, or MEASURpoint instruments to a private LAN using a dedicated Ethernet hub or switch.

Note: Use standard LAN cables for network connections. The instrument ships with a standard LAN cable (EP372) for connecting to the LAN (RJ45) connector on the rear panel of the instrument.

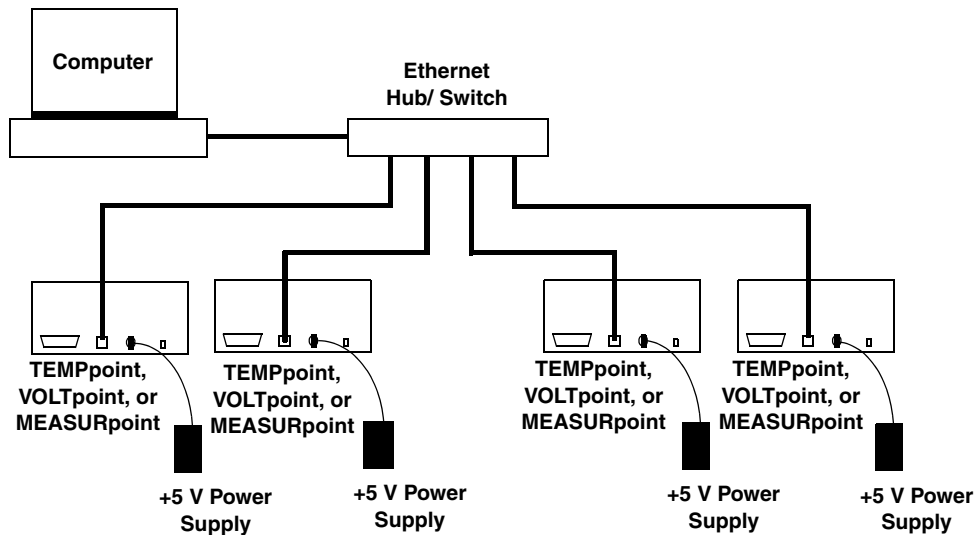

Figure 4: Typical Private LAN Connections using a Hub or Switch

Connecting Directly to a Computer

Optionally, you can connect the TEMPpoint, VOLTpoint, or MEASURpoint instrument directly to your computer, creating an ad hoc network, as shown in [Figure 5](#). Be aware that the time and date settings of the instrument will not be updated using this connection method. Therefore, this connection scheme is generally recommended for quick set up and verification only.

Note: TEMPpoint, VOLTpoint, and MEASURpoint instruments do not support the Auto-MDIX function; therefore, use a crossover cable rather than a standard LAN cable to connect your instrument unless your computer has enabled the Auto-MDIX function.

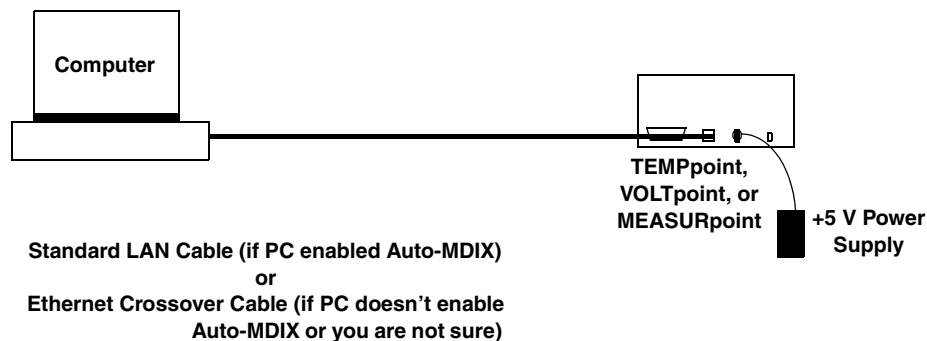

Figure 5: Typical Private LAN Connections when Connecting Directly to a Computer

Applying Power

TEMPpoint, VOLTpoint, and MEASURpoint instruments are shipped with an EP361 +5V power supply and cable. To apply power to the instrument, do the following:

1. Connect the +5 V power supply to the power connector on the rear panel of the instrument. Refer to [Figure 6](#).

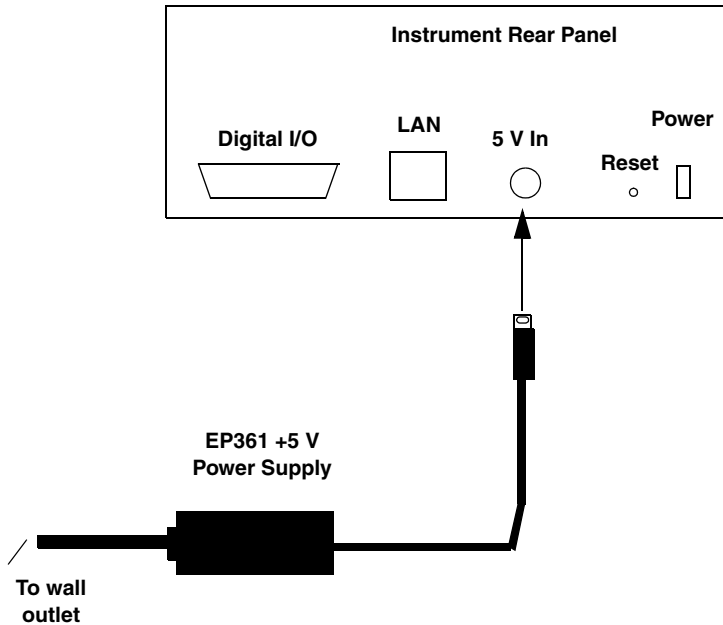

Figure 6: Attaching a +5 V Power Supply to the Instrument

2. Plug the power supply into a wall outlet.

Note: For proper grounding of your measurement instrument, ensure that you use the power supply and cable (EP361) that is provided with the instrument and that you use all three prongs of the cable when connecting it to your wall outlet.

3. Press the Power switch on the rear panel of the instrument, shown in [Figure 6](#), to turn on the instrument.

The Power LED on the front panel lights to indicate that power is on.

[Figure 7](#) shows the front panel of the instrument, including the locations of the LEDs.

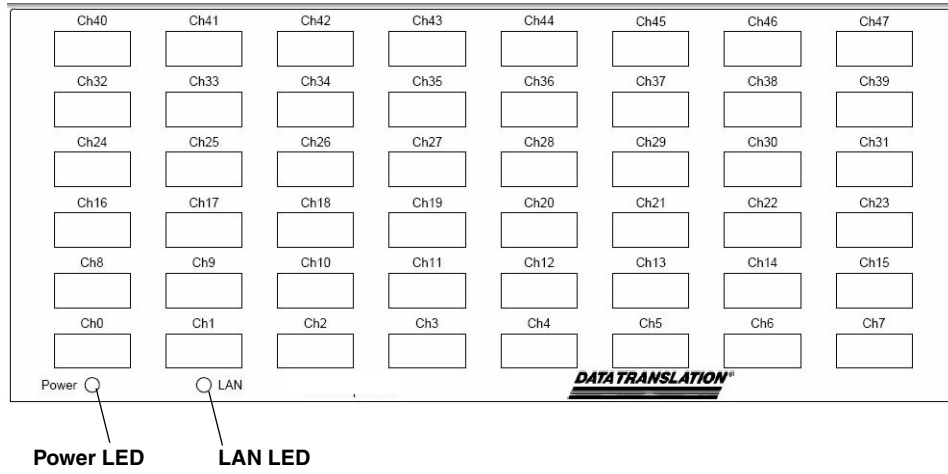

Figure 7: Front Panel of the Instrument

Getting an IP Address and Host Name

Once your instrument is connected to the LAN and powered on, the instrument automatically requests an Ethernet address from a DHCP (Dynamic Host Configuration Protocol) server, if available, and a host name from a DNS (Dynamic Domain Name Service) server, if available.

If these services are not available on the LAN, the instrument uses Auto-IP to set up its TCP/IP configuration. In this case, the IP address is in the range of 169.254.0.0 to 169.254.255.255 with a subnet mask of 255.255.0.0.

Note: If no DHCP server exists and your PC is set up to use a static IP address, you must temporarily reconfigure your PC to use Auto-IP, then configure your instrument to use a static IP address, as described in [Appendix D](#) starting on [page 153](#).

You can use the instrument's web interface, described in [Chapter 5](#) starting on [page 65](#), to see the IP address and host name that is assigned to your instrument.

Notes: When programming a TEMPpoint, VOLTpoint, or MEASURpoint instrument, you access the instrument through its address string, which consists of an IP address or host name, such as **TCPIP0::192.43.218.69::inst0::INSTR** or **TCPIP0::192.43.218.69::SOCKET**. If a host name was returned by the DNS server, you can also address the instrument using its host name, such as **TCPIP0::arrakis.datx.com::inst0::INSTR**.

For IVI-COM programmers, you can also assign a VISA alias to the instrument. For example, rather than addressing the instrument as **TCPIP0::192.43.218.69::inst0::INSTR**, you can a VISA alias, such as **TEMPpoint1**, instead. See your VISA documentation for more information on VISA resource strings and creating VISA aliases.

Determining Ethernet Activity

You can use the ENet Link and ENet Activity LEDs on the rear of the instrument, shown in [Figure 8](#), with the LAN LED on the front of the instrument, shown in [Figure 7](#), to determine the Ethernet activity on your instrument. [Table 1](#) describes the meaning of these LEDs.

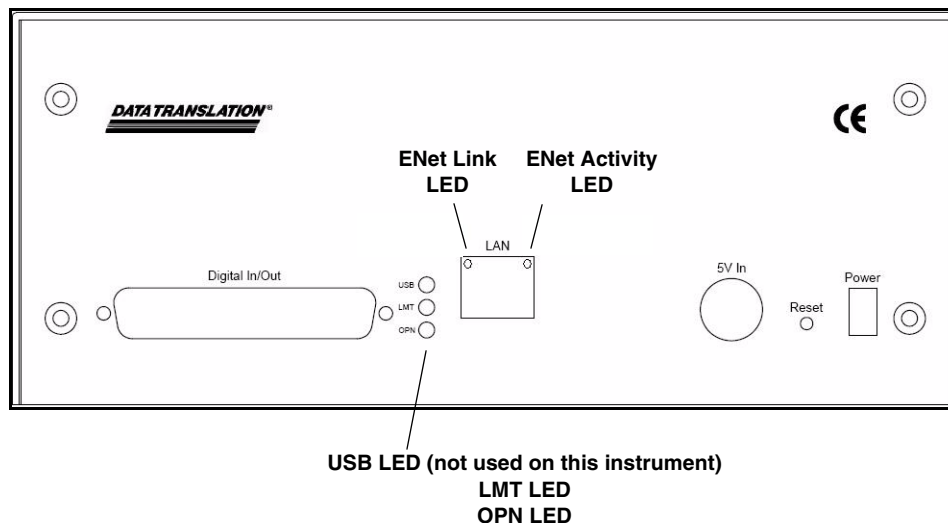

Figure 8: Rear Panel of the Instrument

Table 1: Using LEDs to Determine Ethernet Activity

LEDs	Color	Description
LAN LED (on front panel)	Solid Green	Instrument has valid IP address.
	Blinking Green	Instrument identified using the Web interface; see page 72 for more information.
	Red	If the Ethernet link is operational, the instrument does not have a valid IP address. Otherwise, the Ethernet link is not operational.
ENet Link LED (on rear panel)	Yellow	Ethernet link operational.
	Off	Ethernet link not operational.
ENet Activity LED (on rear panel)	Green	Network traffic detected.
	Off	No network traffic detected.

Resetting the Instrument

If needed, you can restore the default configuration of your instrument by pressing the Reset pin on the rear panel of the instrument, shown in [Figure 8 on page 43](#), until the LAN LED on the front panel turns off (which takes approximately 5 seconds), and then releasing the Reset pin.

The instrument reboots automatically using the factory-default LAN configuration (DHCP and auto-IP enabled); this process typically takes up to 40 seconds to complete. This forces the instrument to re-acquire an IP address from the DHCP server, or if that fails, to use Auto-IP to get an IP address.

Note: The default configuration overwrites any changes that you have made to the LAN configuration (IP address and password) using the instrument's web interface.

The calibration parameters are not affected by the reset.



Wiring Signals

General Wiring Recommendations	47
Warm-Up Time	48
Connecting Thermocouple Inputs	49
Connecting RTD Inputs	51
Connecting Voltage Inputs	55
Connecting Current Loop Inputs	58
Connecting Digital I/O Signals	62

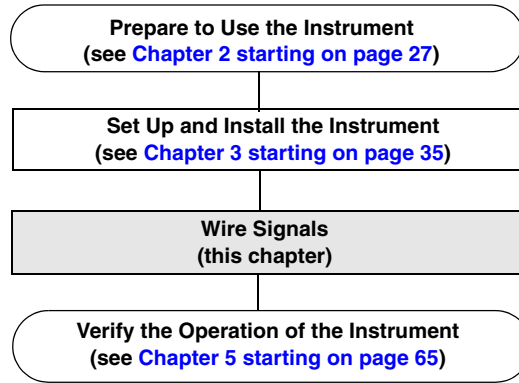

General Wiring Recommendations

Keep the following recommendations in mind when wiring signals to a TEMPpoint, VOLTpoint, or MEASURpoint instrument:

- Separate power and signal lines by using physically different wiring paths or conduits.
- To avoid noise, do not locate the instrument and cabling next to sources that produce high electromagnetic fields, such as large electric motors, power lines, solenoids, and electric arcs, unless the signals are enclosed in a mumetal shield.
- Locate the instrument's front panel as far away as possible from sources of high or low temperatures or strong air currents, such as fans.
- Prevent electrostatic discharge to the I/O while the instrument is operational.
- When wiring thermocouples, select an appropriate wire length and gauge for each thermocouple; in general, use the shortest wire length and largest gauge for the application to yield best results.
- Use shielded wire for maximum rejection of electrical interference.

Warm-Up Time

For accurate thermocouple measurements, DT8871U and DT8871 TEMPpoint instruments and thermocouple channels on the DT8874 MEASURpoint instruments require a warm-up time of 45 minutes for the analog circuitry to stabilize.

For accurate high voltage measurements, the DT8873 VOLTpoint instruments and high voltage channels on the DT8874 MEASURpoint instruments require a warm-up time of 1 hour for the analog circuitry to stabilize.

For accurate RTD measurements, the DT8872 TEMPpoint instruments and RTD channels on the DT8874 MEASURpoint instruments require a warm-up time of 1 minute for the analog circuitry to stabilize.

Connecting Thermocouple Inputs

The DT8871U, DT8871, and DT8874 instruments contain Cu-Cu thermocouple jacks for connecting thermocouple inputs.

Note: On the standard DT8874 instrument, channels 0 to 15 correspond to the thermocouple input channels.

Internally, these signals are connected in differential mode. You can mix and match the following thermocouple types across channels: B, E, J, K, N, R, S, and/or T.

Each Cu-Cu thermocouple input jack is polarized and accepts a mating Cu-Cu plug in the appropriate orientation. Table 2 lists the color designations for the + and – polarities of the supported thermocouple types for both the ANSI (American) and IEC (International) standards.

Table 2: Thermocouple Color Designation Standards

Thermocouple Standard	Thermocouple Type	Wire Color Coding + Polarity	Wire Color Coding – Polarity
ANSI	Type J	White	Red
	Type K	Yellow	Red
	Type T	Blue	Red
	Type E	Violet	Red
	Type S	Black	Red
	Type R	Black	Red
	Type B	Gray	Red
	Type N	Orange	Red
IEC	Type J	Black	White
	Type K	Green	White
	Type T	Brown	White
	Type E	Violet	White
	Type S	Orange	White
	Type R	Orange	White
	Type B	Gray	White
	Type N	Pink	White

For more information on thermocouple standards, refer to the following web site:

<http://www.omega.com/thermocouples.html>.

Figure 9 shows how to connect a thermocouple input to a thermocouple channel.

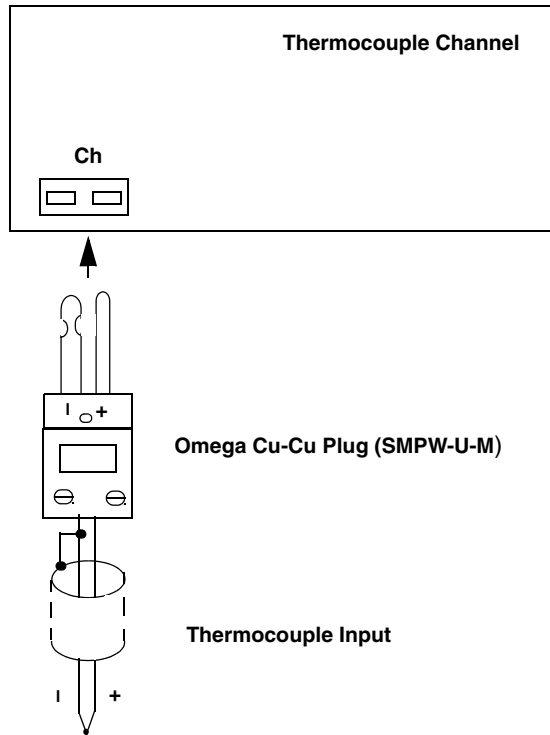

Figure 9: Connecting Thermocouple Inputs

Connecting RTD Inputs

Each DT8872 and DT8874 contains pluggable screw terminals for connecting RTD inputs.

Note: On the standard DT8874 instrument, channels 16 to 31 correspond to the RTD input channels.

Internally, these signals are connected in differential mode. Figure 10 shows the numbering of the screw terminal blocks for RTD connections.

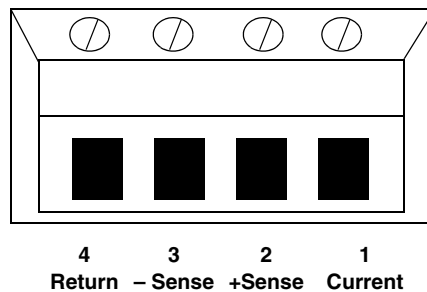

Figure 10: Screw Terminal Block Numbering for RTD Connections

Note: To make wiring easier, use the supplied screwdriver to attach your signals to the screw terminal blocks. When you are finished, plug the screw terminal block into the screw terminal header that corresponds to the channel to which you are wiring.

The DT8872 supplies each RTD channel with 425 μA of excitation current to prevent self-heating. The resistance of the RTD circuit increases gradually, repeatably, and linearly with temperature. As the resistance increases, the voltage drop across the RTD also increases. The DT8872 reads this voltage drop and automatically converts the voltage to the appropriate temperature based on the RTD type.

The DT8872 and DT8874 support Pt100 (100 Ω Platinum), Pt500 (500 Ω Platinum), and Pt1000 (1000 Ω Platinum) RTD types using Alpha coefficients of 0.00385 and 0.00392; you can mix and match RTD types across RTD channels. Refer to the following web site for more information on RTD types: <http://www.omega.com>.

To connect an RTD input, you can use a 4-wire, 3-wire, or 2-wire connection scheme, described in the following subsections. For the best accuracy, use 4-wire RTD connections; this connection scheme enables Kelvin sensing to minimize errors due to lead wire resistance.

4-Wire RTD Connections

The 4-wire configuration offers the best accuracy with long connection wires, compared to the 3- and 2-wire configurations. The 4-wire connection scheme eliminates errors due to lead wire resistance (R_L) and thermal heating. Wire impedance of up to 100 Ω anywhere in the hookup is automatically cancelled as long as the sense wires are connected.

Figure 11 shows a 4-wire RTD connection.

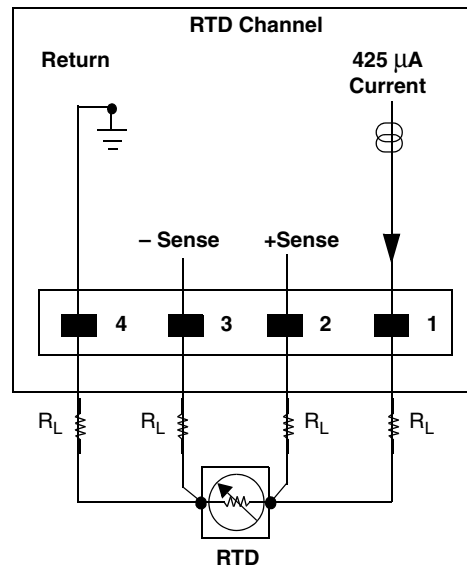

Figure 11: 4-Wire RTD Connection

3-Wire RTD Connections

The 3-wire configuration eliminates one wire from the 4-wire RTD connection. Lead wire resistance (R_L) errors in the return wire from -Sense may be introduced unless the voltage drop is essentially equal and opposite to the voltage drop across +Sense.

Figure 12 shows a 3-wire RTD connection.

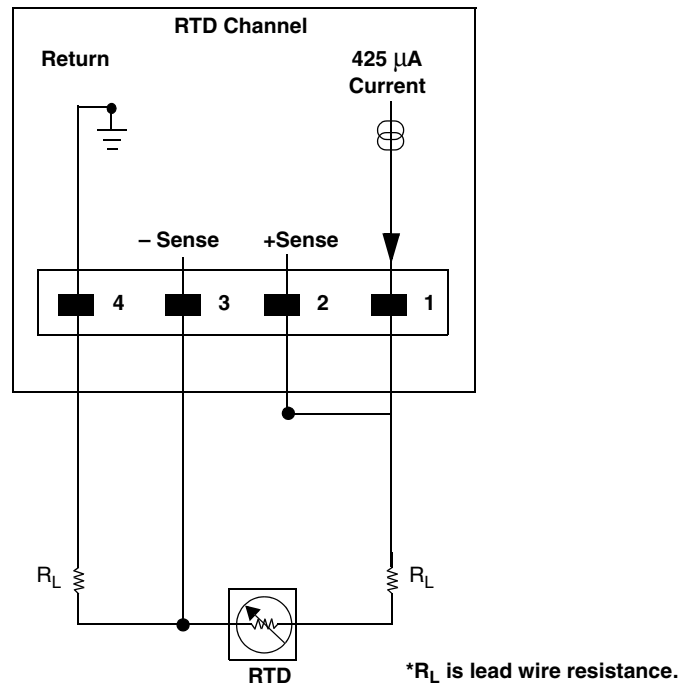

Figure 12: 3-Wire RTD Connection

2-Wire RTD Connections

The 2-wire configuration is the least accurate of the RTD wiring configurations because the lead wire resistance (R_L) and its variation with temperature contribute significant measurement errors, particularly if the lead wire is long. If you decide to use the 2-wire connection scheme, ensure that you use short lead wire connections.

For example, if the lead resistance is 0.5Ω in each wire, the lead resistance adds a 1Ω of error to the resistance measurement. Using a 100Ω RTD (Pt100) with a $0.00385/^\circ\text{C}$ European curve coefficient, the resistance represents an initial error of $1 \Omega / (0.385 \Omega / ^\circ\text{C})$ or 2.6°C . Since the lead wire resistance changes with ambient temperature, additional errors are also introduced in the measurement.

Figure 13 shows a 2-wire RTD connection.

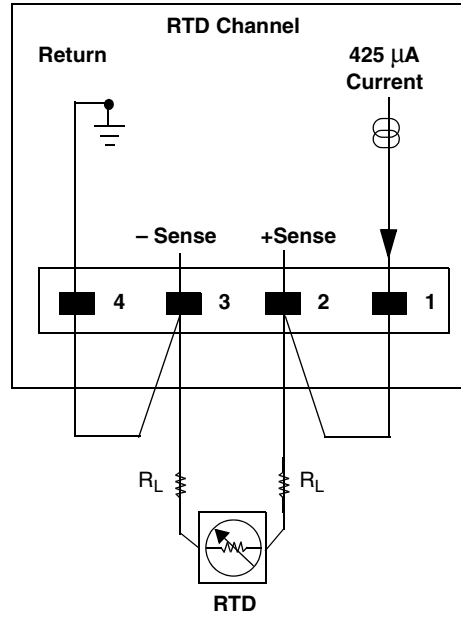

Figure 13: 2-Wire RTD Connection

Connecting Voltage Inputs

The way you connect voltage inputs depends on the channel type you are using. This section describes how to connect voltage inputs to thermocouple input channels, RTD input channels, and high voltage input channels.

Connecting Voltage Inputs to Thermocouple Channels

Figure 14 shows how to connect a differential voltage input to a thermocouple input channel on the DT8871U, DT8871, or DT8874 instrument.

Note: On the standard DT8874 instrument, channels 0 to 15 correspond to the thermocouple input channels.

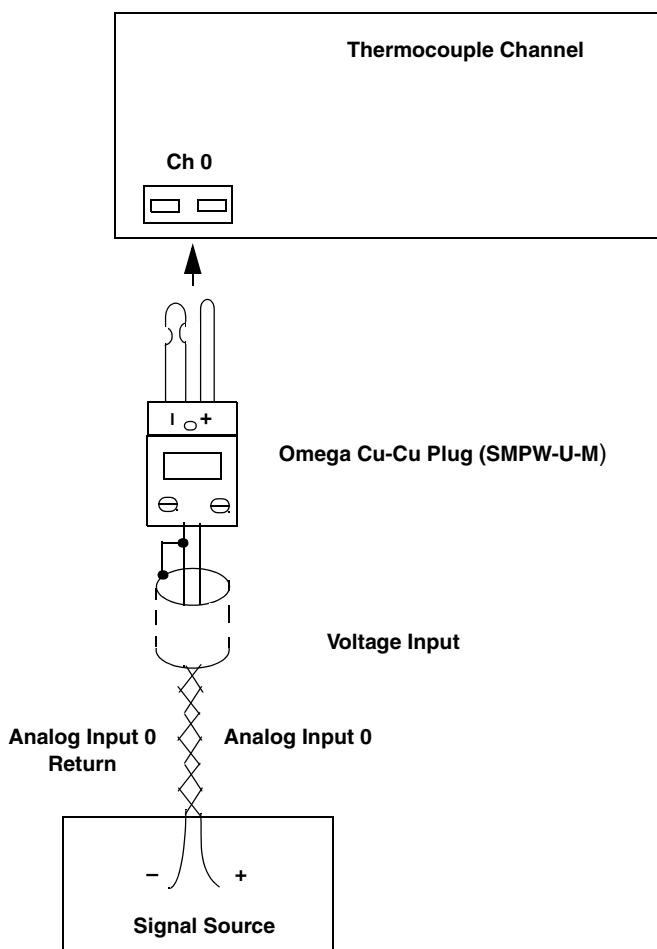

Figure 14: Connecting Voltage Inputs to a Thermocouple Channel

Connecting Voltage Inputs to RTD Channels

Figure 15 shows how to connect a voltage input to an RTD channel on a DT8872 or DT8874 instrument.

Note: On the standard DT8874 instrument, channels 16 to 31 correspond to the RTD input channels.

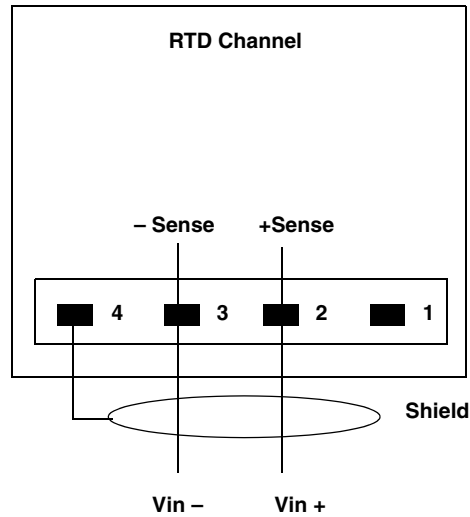

Figure 15: Connecting Voltage Inputs to an RTD Channel

The input impedance is well over 100 M Ω using the voltage -Sense and +Sense inputs.

For best accuracy when connecting voltage inputs, use twisted-pair wires with a dead-ended shield connected to pin 4 of the screw terminal block.

Connecting Voltage Inputs to High Voltage Channels

Each DT8873 and DT8874 contains pluggable screw terminals for connecting high voltage inputs.

Note: On the standard DT8874 instrument, channels 32 to 47 correspond to the high voltage input channels.

Figure 16 shows the numbering of the screw terminal blocks for high voltage connections.

Connecting Current Loop Inputs

In some applications, such as solar cell, fuel cell, and car battery testing applications, you may want to accurately sense and measure current in a high voltage loop.

TEMPpoint, VOLTpoint, and MEASURpoint instruments provide channel-to-channel isolation of ± 500 V, meaning that each input can be referenced to ± 500 V.

The way you connect current loop inputs depends on the channel type you are using. This section describes how to connect current loop inputs to thermocouple input channels, RTD input channels, and high voltage input channels.

Connecting Current Loop Inputs to Thermocouple Channels

Thermocouple input channels on the DT8871U and DT8874 have an input range of ± 0.075 V. Therefore, you can use a $1\ \Omega$ series resistor to measure ± 0.075 A. Similarly, you can use a $0.1\ \Omega$ series resistor to measure ± 0.75 A.

Thermocouple input channels on the DT8871 have an input range of ± 1.25 V. Therefore, you can use a $1\ \Omega$ series resistor to measure ± 1.25 A. Similarly, you can use a $0.1\ \Omega$ series resistor to measure ± 12.5 A or a $10\ \Omega$ series resistor to measure ± 0.125 A.

[Figure 18](#) shows how to wire your signals to measure a current loop. In this example, the input is referenced to ± 80 V.

Note: On the standard DT8874 instrument, channels 0 to 15 correspond to the thermocouple input channels.

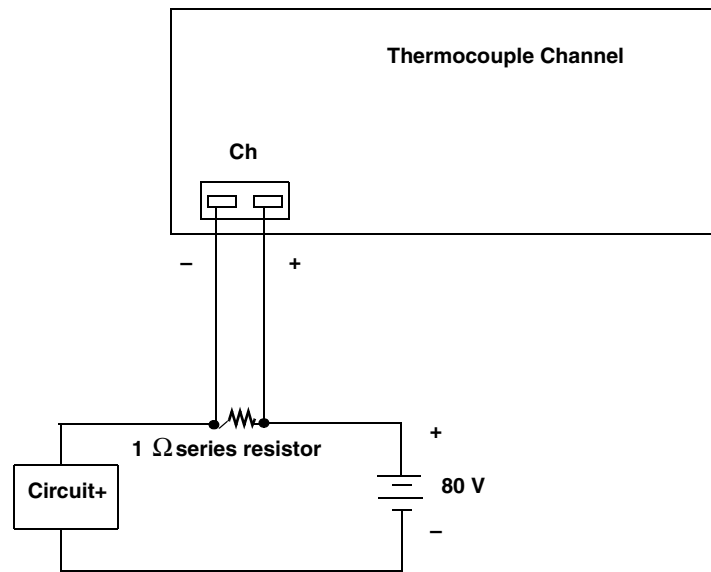

Use a 1 Ω series resistor to convert current to voltage.

For thermocouple channels on the DT8871U and DT8874, 1 $\Omega = 0.075 \text{ A} = 0.075 \text{ V}$.
 For thermocouple channels on the DT8871, 1 $\Omega = 1.25 \text{ A} = 1.25 \text{ V}$.

Figure 18: Connecting Current Loop Inputs to Thermocouple Channels

Connecting Current Loop Inputs to RTD Channels

RTD channels on the DT8872 and DT8874 instruments have an input range of $\pm 1.25 \text{ V}$. Therefore, you can use a 1 Ω shunt resistor to measure $\pm 1.25 \text{ A}$. Similarly, you can use a 0.1 Ω shunt resistor to measure $\pm 12.5 \text{ A}$ or a 10 Ω shunt resistor to measure $\pm 0.125 \text{ A}$.

Figure 19 shows how to wire your signals to measure a current loop. In this example, the input is referenced to $\pm 80 \text{ V}$.

Note: On the standard DT8874 instrument, channels 16 to 31 correspond to the RTD input channels.

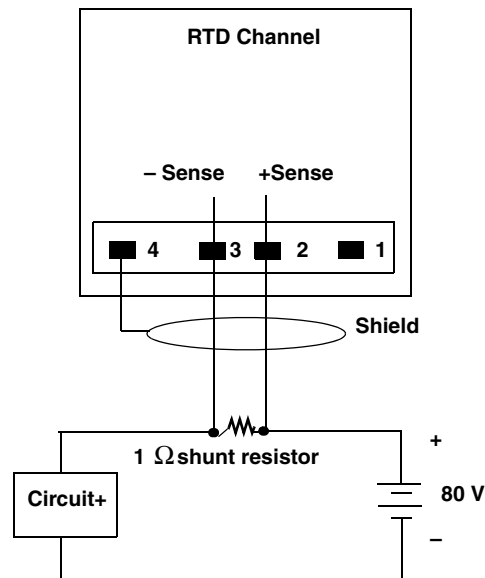

Use a 1 Ω shunt resistor to convert current to voltage: $1 \Omega = 1.25 \text{ A} = 1.25 \text{ V}$.

Figure 19: Connecting Current Loop Inputs to RTD Channels

Connecting Current Loop Inputs to High Voltage Channels

High voltage channels on the DT8873 and DT8874 instruments have an input range of $\pm 10 \text{ V}$, $\pm 100 \text{ V}$, or $\pm 400 \text{ V}$. You select the input range for each channel using software.

Note: On older versions of the instrument, the input range was fixed and depended on the model you purchased.

With the 24-bit A/D converter, high current, high side current shunts can be used for resolutions of less than 0.01 A on a 100 A range.

Typical Shunts:

- Vishay WSMS5515
.2 m Ω – 2 Ω – 100 A – 20 μV
- Vishay CSM2512S
10 m Ω – 1 Ω – 10 A – 100 μV
- Deltec MUB-500-50
.1 m Ω – 25 Ω – 500 A – 50 μV

Note: The resolution is ± 2 mV on a ± 100 V range and ± 0.3 mV on the ± 10 V range. Since the resolution of the ± 400 V range is ± 8 mV, using current loop inputs with this range is impractical in most applications.

On the standard DT8874 instrument, channels 32 to 47 correspond to the high voltage input channels.

Figure 20 shows an example of wiring signals to measure ± 20 mA using the ± 10 V input range.

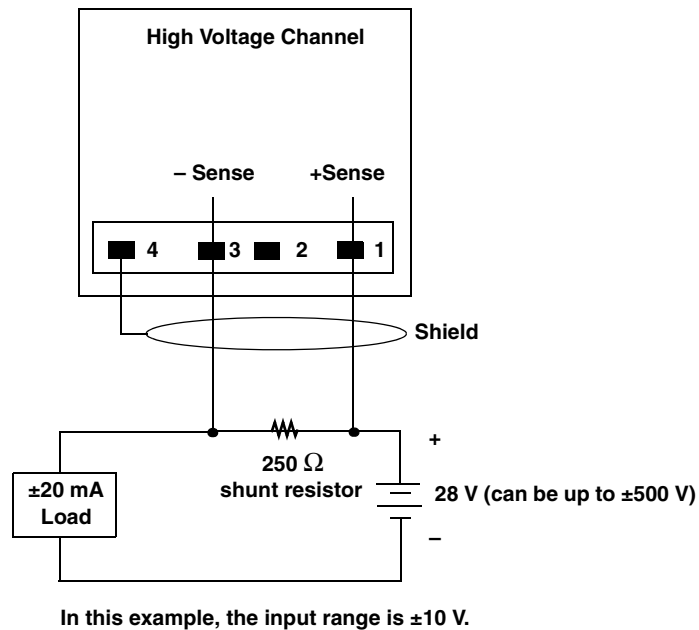

Figure 20: Connecting a Current Loop Input to a High Voltage Channel to Measure ± 20 mA

Connecting Digital I/O Signals

To make digital I/O connections easier, you can use the optional STP37 screw terminal panel and EP333 cable with your TEMPpoint, VOLTpoint, or MEASURpoint instrument. Connect the STP37 to the digital I/O connector of the instrument as shown in Figure 21:

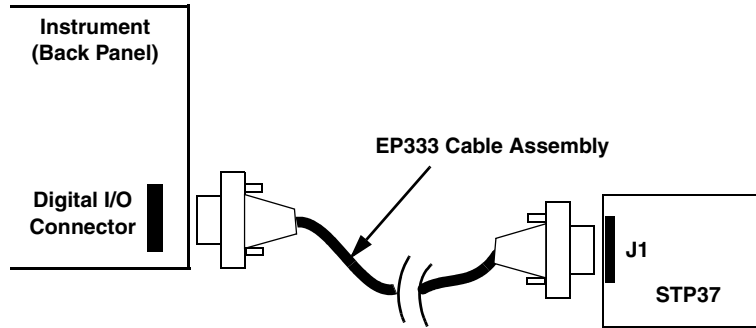

Figure 21: Connecting the Instrument to the STP37

Figure 22 shows the layout of the STP37 screw terminal panel and lists the assignments of each screw terminal.

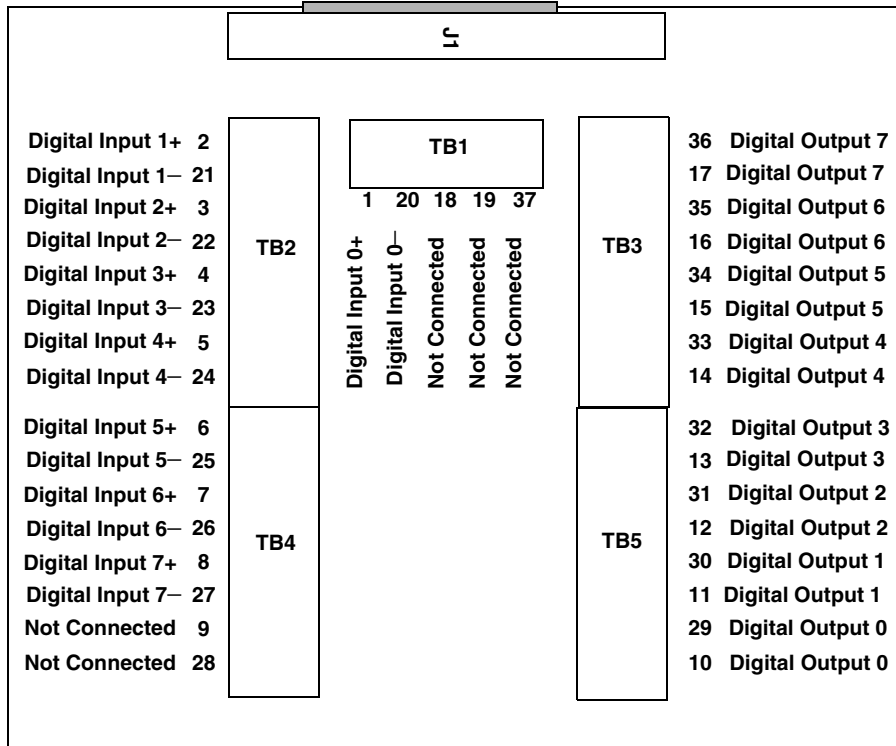
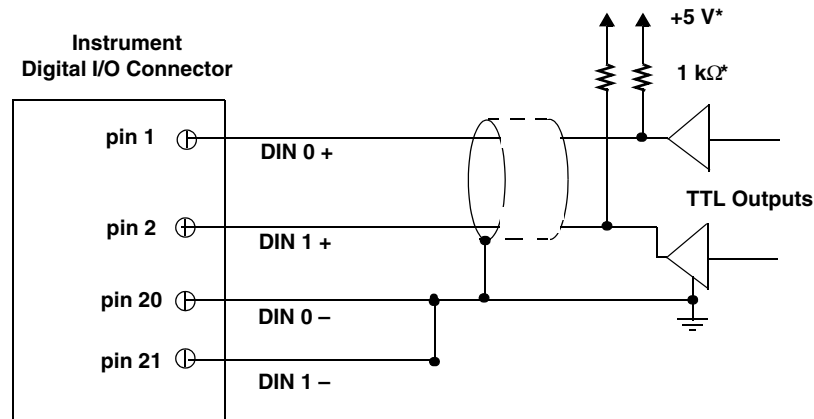

Figure 22: STP37 Screw Terminal Panel

Connecting Digital Input Signals

Figure 23 shows how to connect digital input signals (lines 0 and 1, in this case) to the digital I/O connector on the TEMPpoint, VOLTpoint, or MEASURpoint instrument.



*1 kΩ pull-up to +5 V required for TTL outputs.

Figure 23: Connecting Digital Inputs

Connecting Digital Output Signals

The digital output lines of a TEMPpoint, VOLTpoint, or MEASURpoint instrument act as solid-state relays. The customer-supplied signal can be ± 30 V at up to 400 mA (peak) AC or DC.

You can use the digital output lines of the instrument to control solid-state or mechanical relays or high-current electric motors. Figure 24 shows how to connect digital output signals to line 0 of the instrument to control a motor relay.

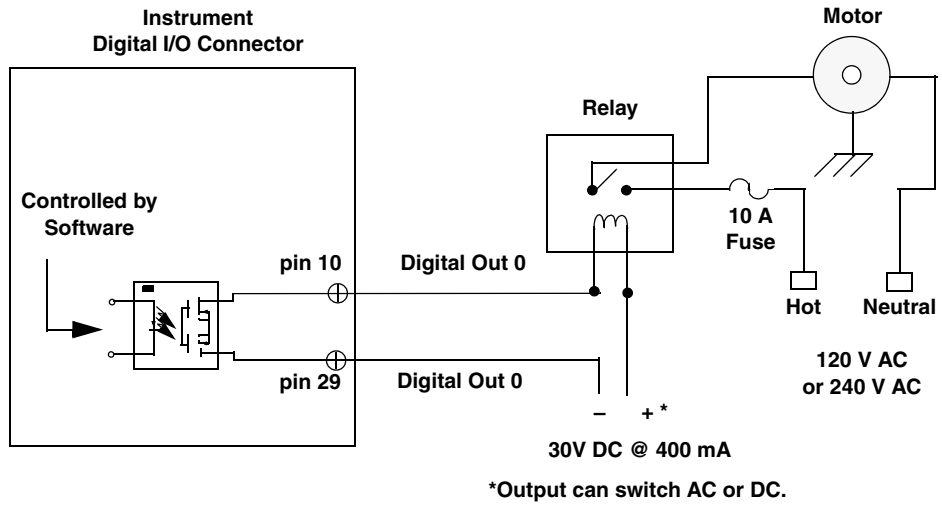
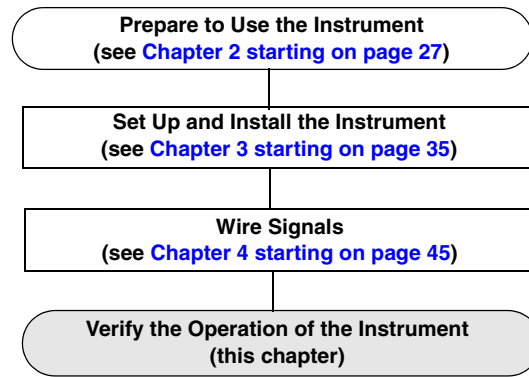

Figure 24: Switching up to 30 V at 400 mA



Verifying the Operation of Your Instrument

Before Using the Web Interface	67
Locating Your Instrument on the LAN	72
Configuring the Instrument	78
Measuring Data and Controlling the Instrument	85
Downloading Measurements	89



You can verify the operation of your instrument using the instrument’s web interface.

You can configure, measure, and control the instrument either locally or remotely using this interface.

You can also use the provided Measurement Application, developed in Measure Foundry, for more complex data analysis. This chapter focuses on verifying your instrument using the web interface; refer to [Appendix C](#) starting on [page 139](#) for information on using the Measurement Application.

Before Using the Web Interface

This section describes system requirements and browser settings for proper operation of the instrument's web interface.

Note: At any instant, up to 8 clients can access the instrument concurrently using the web interface.

Up to 12 additional clients can access the instrument concurrently using SCPI commands over VISA or sockets. Of these, 4 can be VXI-11 clients, which use the ::SOCKETS or VISA::INSTR resource to access the instrument.

At this time, the web and SCPI interfaces cannot be "locked;" therefore, one client can change the configuration of the instrument that another client is accessing. However, you can optionally lock the VXI-11 interface using the VISA APIs viLock/viUnlock; this prevents other VXI-11 clients (including VXI-11 discovery) from accessing the instrument. Refer to the SCPI documentation for your instrument for more information on supported SCPI commands.

Java Requirements

Before using the instrument web interface, ensure that your computer has Version 6, Update 5 or greater of Java installed; this version of Java installs version 1.6 of the Java plug-in. To download or upgrade Java, go to www.java.com.

To verify that you have version 1.6 of the Java plug-in installed, do the following:

1. Launch version 6.0 or 7.0 of Internet Explorer.
2. From the Internet Explorer browser, select **Tools** -> **Sun Java Console**.
The Java Console window appears.
3. Verify that version 1.6 or greater of the Java plug-in installed:

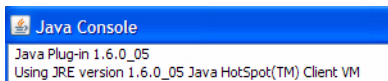

Internet Explorer Browser Settings

For proper operation of the instrument's web interface, ensure that your Internet Explorer 6.0 or 7.0 browser is configured as follows:

- JavaScript (Active Scripting) must be enabled
- Security level of the instrument's IP address must be Medium-high or lower
- Pop-up blockers must be disabled

The following sections describe how to configure these settings.

JavaScript

To enable JavaScript (also referred to as Active Scripting), perform the following steps:

1. From the Internet Explorer browser, select **Tools -> Internet Options**.
2. Click the **Security** tab.
3. Select **Internet**, and then click **Custom Level**.
4. Scroll down to the **Scripting** section.

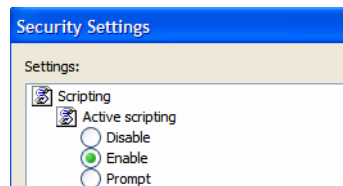

5. Under **Active Scripting**, select **Enable**, and then click **OK**.

Security Levels

By default, the IP address of the instrument is added to the Internet zone. If you'd rather leave the settings of the Internet zone at a level higher than Medium-high, then you can add the IP address of the instrument to either the Local intranet or Trusted sites zone and configure the security level of that zone to Medium-high or lower.

The following section describe how to configure each zone.

Internet Zone

To configure the security level of the instrument's IP address in the Internet zone, perform the following steps:

1. From the Internet Explorer browser, select **Tools -> Internet Options**.
2. Click the **Security** tab.

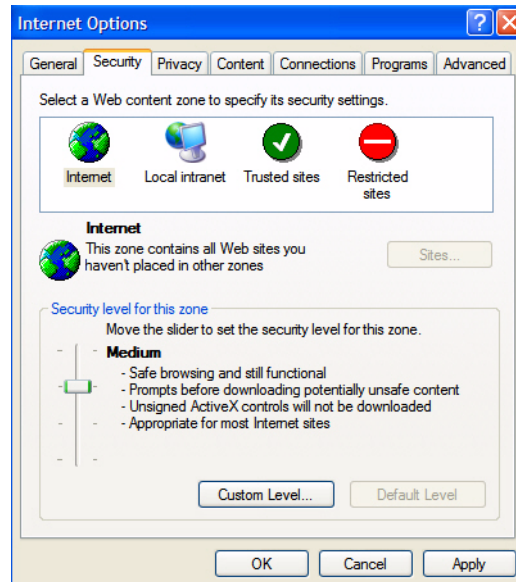

3. Select **Internet**, click **Default Level**, and move the slide bar to select a security level of Medium-high or lower.
4. Click **OK**.

Local Intranet Zone

To add the instrument's IP address to the **Local intranet** zone and configure its security level, do the following:

1. From the Internet Explorer browser, select **Tools** -> **Internet Options**.
2. Click the **Security** tab.
3. Click **Local intranet**, and click **Sites**.
4. Select which web sites to add to the zone, and then click **Advanced**.
5. Enter the IP address of the instrument to the zone, and click **Add**.

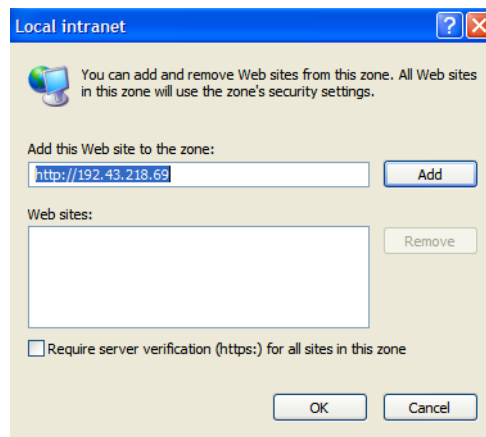

6. Click **OK**.
7. Click **Default Level**, and move the slide bar to select a security level of Medium-high or lower.
8. Click **OK**.

Trusted Sites Zone

To add the instrument's IP address to the **Trusted sites** zone and configure its security level, do the following:

1. From the Internet Explorer browser, select **Tools -> Internet Options**.
2. Click the **Security** tab.
3. Click **Trusted sites**, and click **Sites**.
4. Enter the IP address of the instrument to the zone (note that the address must be prefaced by (https://)), and click **Add**.

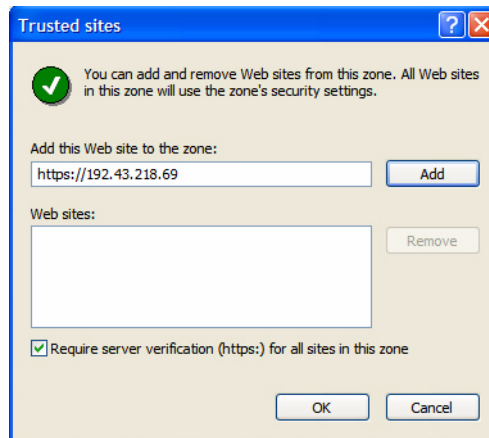

5. Click **OK**.
6. Click **Default Level**, and move the slide bar to select a security level of Medium-high or lower.
7. Click **OK**.

Pop-up Blockers

To disable pop-up blockers, perform the following steps:

- a. From the Internet Explorer browser, select **Tools ->Pop-up Blocker**.
- b. Select **Turn Off Pop-up Blocker**.

Associating CSV Files with Microsoft Excel or Notepad

If files with the .CSV extension do not have the proper file associations/actions set up, then clicking **Download** in the Download Measurements page of the instrument web interface will not present the option of saving the data to a file or loading the data to an application, such as Microsoft Excel® or Microsoft® Notepad, that can display it. Instead, the data will be displayed in the browser.

To associate a CSV file with Microsoft Excel or Notepad, perform the following steps:

1. From the Windows **Control Panel**, open the **Folder Options** dialog, and select **File Types**.
2. Scroll down to the **CSV** entry and select it. (If it is not in the list add it as a new file type by selecting **New** and entering **CSV**).
3. Click **Advanced** to access the Edit File Type dialog box.
4. Click **New** to access the New Action dialog box.
5. Enter **Open** in the **Action:** edit field.
6. Click **Browse** and find **Excel.exe** (typically located in C:\Program Files\Microsoft Office\OFFICExx\EXCEL.EXE) or **Notepad.exe** (typically located in C:\Windows\Notepad.exe) on your system, and then click **OK**.

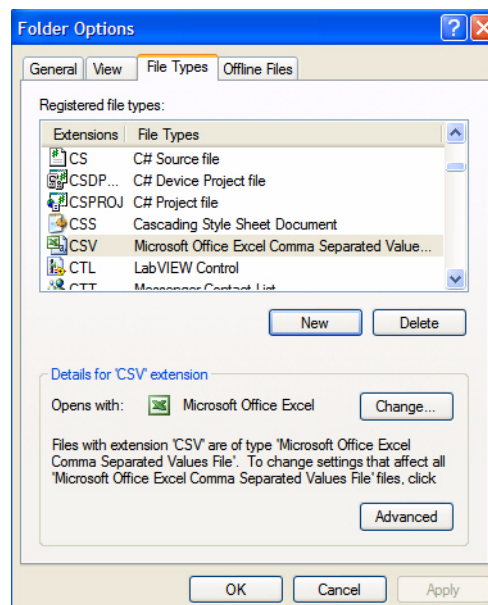

7. Click **OK**.

Now when you click **Download** on the Download Measurements web page, you should see a dialog box asking if you want to Open or Save the data in the appropriate application.

Locating Your Instrument on the LAN

To access the web interface of your instrument, you must determine its IP address on your TCP/IP network.

Note: Discovery works only for devices on the same subnet.

We recommend that you run Data Translation's Eureka Discovery Utility that is provided with the instrument to locate your instrument on the network quickly. Alternatively, you can use other LXI discovery tools, such as Agilent Connection Expert, if you have them installed on your computer. Or you can check your router's address assignments or locate the instrument's MAC (Ethernet hardware) address in your DHCP server log.

Running the Eureka Discovery Utility

To use the Eureka Discovery Utility, from the Windows Start menu, click **Programs -> Data Translation, Inc -> Instrument Support -> Eureka LXI Instrument Discovery**.

A screen similar to the one shown in [Figure 25](#) appears.

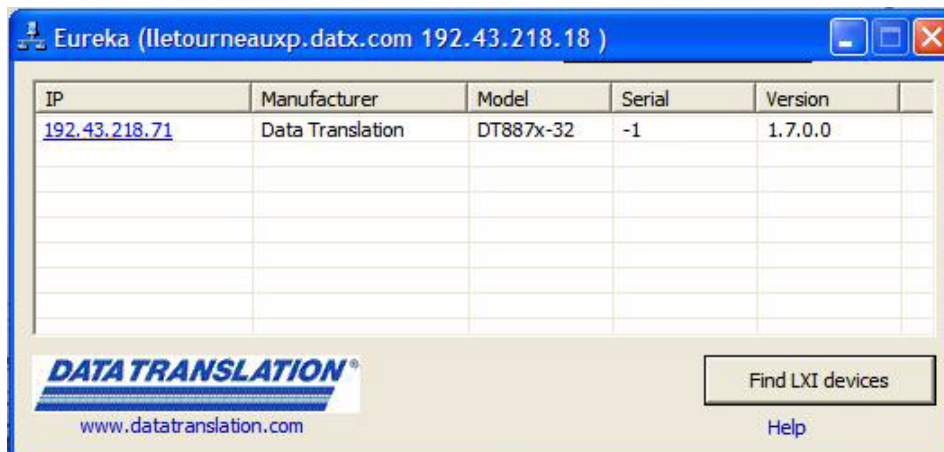

Figure 25: Eureka LXI Discovery Utility

If you are having trouble seeing your instrument in this list, check your Windows firewall settings using the information in the next section; otherwise, skip this section and continue with [“Launching the Web Interface”](#) on page 76.

Configuring Windows Firewall Settings

If you are having trouble seeing your instrument using the Eureka Discovery Utility, check your Windows firewall settings by doing the following:

1. Right click in the tile bar of the Eureka Discovery Utility.

The following menu options appear:

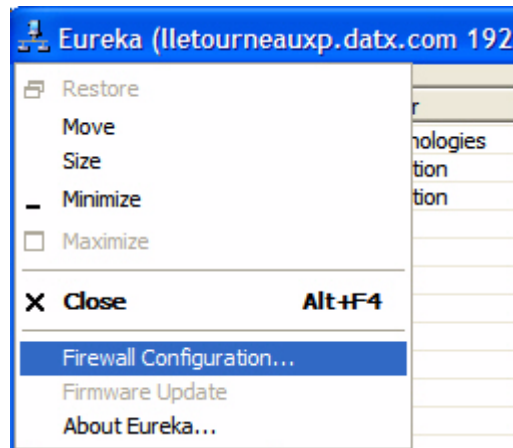

2. Click the **Firewall Configuration...** option.

The following window appears:

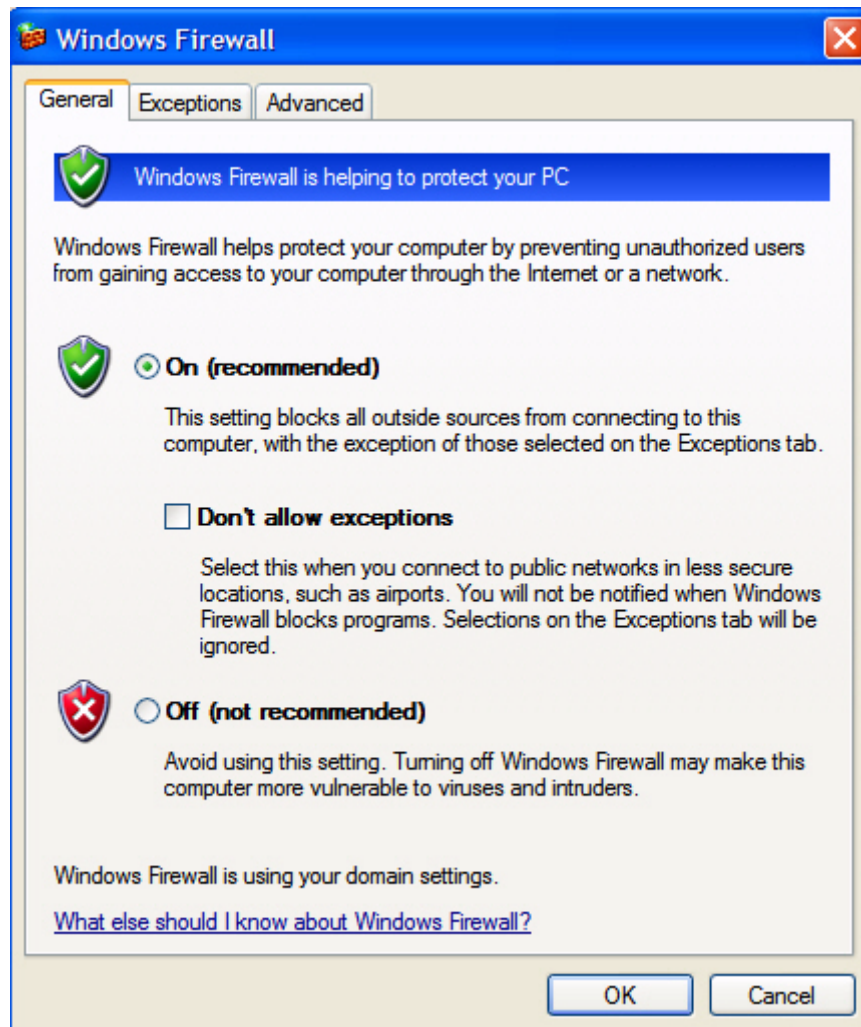

3. From the **General** tab, select the **On (recommended)** setting for proper operation of the Eureka Discovery Utility.
4. Click the **Exceptions** tab, and ensure that Eureka LXI Instrument Discovery is included in the list of exceptions:

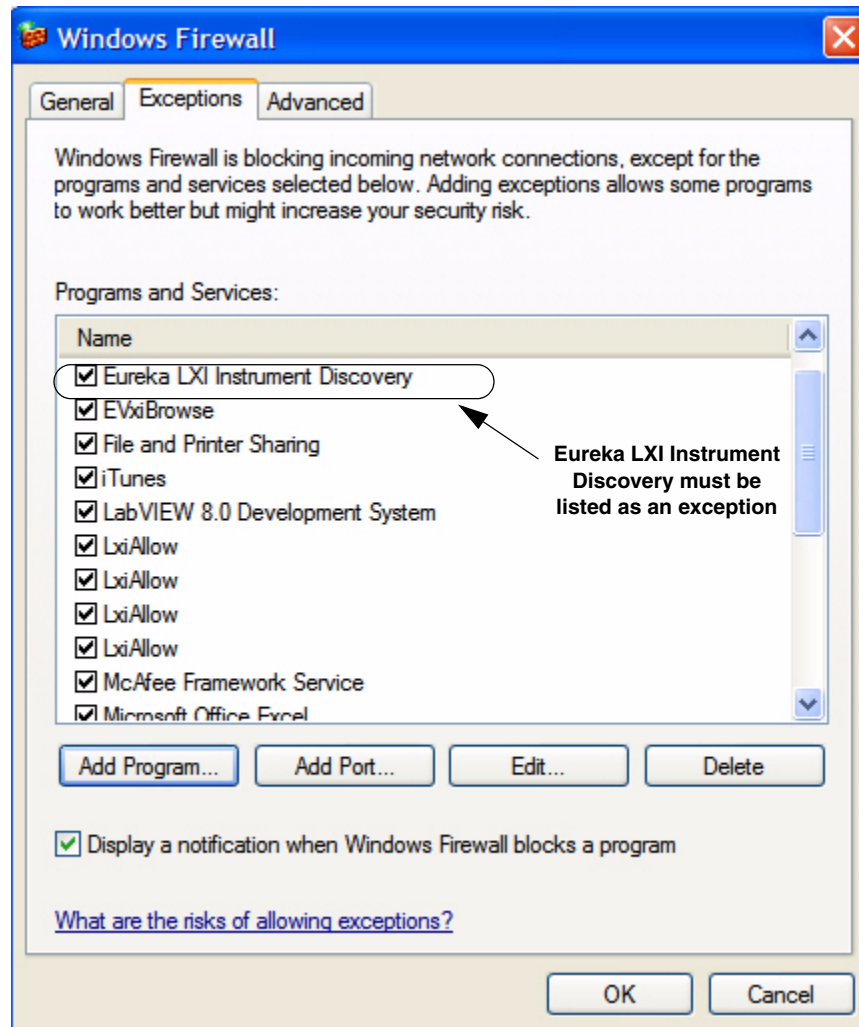

5. If Eureka LXI Instrument Discovery is not included in the exception list, add the utility to the list of exceptions by doing the following:
 - a. Click **Add Program...**
 - b. Browse to **C:\Program Files\Data Translation\Instrument Support\Eureka.exe**.
The Eureka LXI Instrument Discovery utility appears in the window:

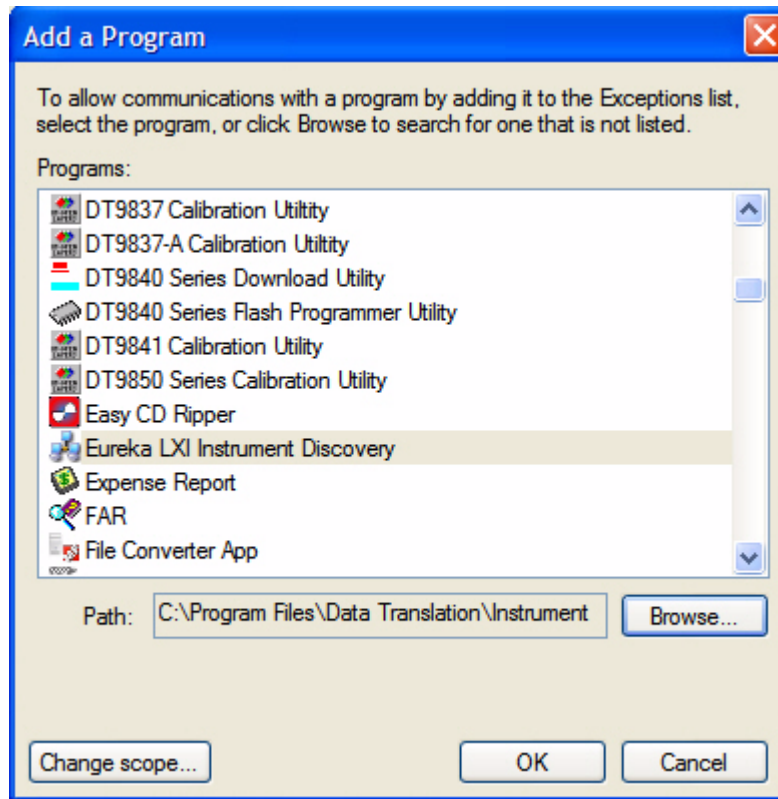

- c. Click **OK** to add the utility to the list of exceptions.
- d. Click **OK** to exit from the Windows Firewall Configuration menu.

Launching the Web Interface

From the Eureka utility, double-click the appropriate IP address to open the web pages for your instrument using your default web browser. Alternatively, you can enter the IP address of your instrument directly in your Internet Explorer address bar to see the instrument's web interface.

The main web page, similar to the following screen, shows information about your instrument on the network:

DT887x-32	
Home	Home
Configuration	Turn ON front panel identification indicator
LAN	
Channel	
Scan rate	
Filter	
Limits	
Digital Input & Trigger	
Digital Output	
Measurement & control	
Channel	
Digital Input	
Digital Output	
File	
Download Measurements	
Help	
Topics	
Technical Support	

Item	Value
Manufacturer	Data Translation Inc.
Instrument model	DT887x-32
Firmware revision	1.7.0.0
Serial number	-0000001
Description Modify	8-channel TC board with lots of wires
LXI Class	C
LXI version	1.1
Hostname	asellustertius.datx.com
MAC address	00:40:9D:2E:9E:75
IP address Modify	192.43.218.71 (DHCP)
Time source Modify	192.43.244.18
Time Zone Modify	GMT-5
Current Time	Tue Apr 28 1:45 PM 2009
VISA resource string	TCPIP0::asellustertius.datx.com::INSTR TCPIP0::asellustertius.datx.com::5025::SOCKET

If you have multiple instruments connected to the network, you can click "Turn **ON** front panel identification indicator" to light the LAN LED on the instrument, described on [page 41](#), to indicate the device you are using.

To change the description, IP address, or time source associated with the instrument, click the **Modify** links to navigate to the LAN Configuration page, described on [page 78](#).

To change the time zone associated with the instrument, click the **Modify** link. The following screen appears:

Time Zone

GMT

You specify the time zone that is used by the instrument as an offset (either + or -) from GMT (Greenwich Mean Time). The specified hour and minute is added to the UTC (Coordinated Universal Time) time that is maintained by the instrument. For example choosing -5 hours, 0 minutes sets the current time zone used by the instrument to five hours and 0 minutes behind GMT.

Configuring the Instrument

Web pages are provided for configuring the following aspects of your instrument:

- Local Area Network (LAN) settings
- Channels that you want to measure
- Scan rate
- Filter
- Alarm limits
- Digital I/O lines

LAN Configuration

Use the **Configuration** -> **LAN** web page to configure the Local Area Network (LAN) settings for the instrument. A screen similar to the following appears:

The screenshot shows the LAN Configuration page for a DT887x-32 instrument. The page has a navigation menu on the left and a configuration table on the right. The table is titled "LAN Configuration" and has a "Modify" button. The table has two columns: "Item" and "Value".

Item	Value
Hostname	<input type="text"/>
Description	<input type="text" value="8-channel TC board with lots of wires"/>
IP address assignment	<input type="radio"/> DHCP <input checked="" type="checkbox"/> Automatic private IP address enabled <input type="radio"/> Static Static IP Address configuration
	<input type="text" value="192.168.187.163"/> IP <input type="text" value="255.255.255.0"/> Mask <input type="text" value="192.168.187.218"/> Gateway <input type="text"/> Primary DNS <input type="text"/> Secondary DNS
Primary SNTP server	<input type="text" value="192.43.244.18"/>
Secondary SNTP server	<input type="text" value="132.163.4.101"/>
Password	<input type="text"/>

When you first access your instrument, the LAN settings that the instrument obtained through DHCP or AutoIP should be sufficient. If you need to make changes later, click the **Modify** button to enable changes.

Note: If you want to assign a static IP address, ensure that you uncheck the checkbox called **Automatic private IP address enabled**.

When you click **Modify**, you must supply a password for the instrument. The username is **sysadmin**; it cannot be changed. The default password is **user**. You can change the password on this page. Note that the new password goes into effect after the instrument reboots. If you are prompted for a password before the instrument reboots, you must enter your original password.

Contact your system administrator and view the instrument's built-in help pages to determine the correct LAN settings.

Channel Configuration

Use the **Configuration -> Channel** web page to enable the channels that you want to measure, specify the sensor to use for each channel, and add a label to describe each channel, if desired. A screen similar to the following appears:

The screenshot displays the 'Channel Configuration' interface for a DT887x-32 instrument. The interface includes a navigation menu on the left with categories like Configuration, Measurement & control, File, and Help. The main content area shows a table with the following columns: Channel, Enable Channel, Transducer Type, and Label. The 'Enable Channel' column contains checkboxes, all of which are checked. Above this column are 'Enable all' and 'Disable all' buttons. The 'Transducer Type' column contains dropdown menus with various voltage ranges (e.g., ±10V, ±100V, ±400V) and a 'Set all' button. The 'Label' column contains text input fields. The table lists channels from 0 to 15. Channel 0 is labeled '+/-10 V Input', channel 1 is '+/-100 V Input', and channel 2 is '+/-400 V Input'. Channels 3 through 15 have empty label fields.

To change your channel configuration, do the following:

1. Under **Enable Channel**, check the boxes next to the channels that you want to collect data. You can use the **Enable All** and **Disable All** buttons for quick configuration of many channels.
2. Under **Type**, select the sensor type for each configured channel from the drop-down list boxes. If all the channels are of the same type (thermocouple, RTD, or voltage), you can use the **Set all** button to change all channels to the sensor type specified in the heading's drop-down list box.
3. Describe the channels, if desired, by entering text in the **Label** field corresponding to the channel that you want to describe.

4. Click **Save configuration** to apply your changes. If you do not save before leaving this page, your changes are lost.

You can also click the **Discard changes** button (before you save) to return to the previous configuration, if desired.

Scan Rate

Use the **Configuration -> Scan Rate** web page to set the scan rate for all channels on the instrument. A screen similar to the following appears:



To change your instrument's scan rate, do the following:

1. Type a value, in Hertz, between the minimum and maximum shown in the Scan Rate field.

Note: The scan rate that you specify is rounded to the closest "correct" value that the instrument can accept without error. Internally, the 10 Hz clock is divided by an integer in the range of 1 to 65535 (the internal clock divider) to determine the closest value. When you save the scan rate configuration, the actual scan rate is shown.

2. Click **Save configuration** to apply your changes. If you do not save before leaving this page, your changes are lost.

You can also click the **Discard changes** button (before you save) to return to the previous configuration, if desired.

Filter Configuration

Use the **Configuration** -> **Filter** web page to configure the filter type used by the instrument. A screen similar to the following appears:

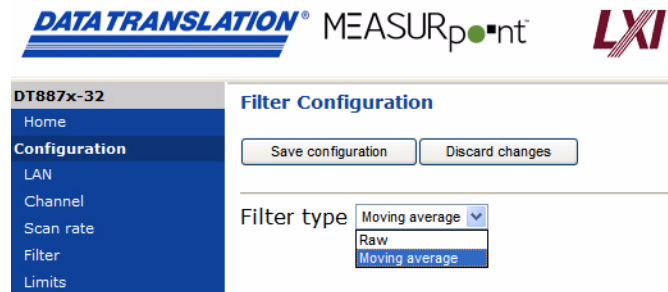

You can choose one of the following filter types:

- **Raw** – No filter. Provides fast response times, but the data may be difficult to interpret. Use when you want to filter the data yourself.

The Raw filter type returns the data exactly as it comes out of the Delta-Sigma A/D converters. Note that Delta-Sigma converters provide substantial digital filtering above the Nyquist frequency.

Generally, the only time it is desirable to use the Raw filter setting is if you are using fast responding thermocouples, sampling them at higher speeds (> 1 Hz), and need as much response speed as possible.

- **Moving average** – (The default filter setting.) Provides a compromise of filter functionality and response time. This filter can be used in any application.

This low-pass filter takes the previous 16 samples, adds them together, and divides by 16.

Alarm Limits Configuration

Use the **Configuration -> Limits** web page to define alarm conditions for specific enabled channels that you want to measure. A screen similar to the following appears.

The screenshot shows the MEASURpoint web interface for DT887x-32. The page title is "Limit Configuration". At the top, there are buttons for "Save configuration" and "Discard changes", and a "Help" link. The main content is a table with the following columns: Channel, Limit, Low Limit, High Limit, and Digital Output. The "Limit" column contains checkboxes for "Enable" and a "Disable all" button. The "Low Limit" and "High Limit" columns contain text boxes with units (°C or Ω or V). The "Digital Output" column contains a drop-down menu with "None" and "1" or "2" options. The table lists 20 channels (0-19). Channels 0-2 are enabled, while channels 3-19 are disabled. Channel 0 has a low limit of 10 °C and a high limit of 100 °C, with digital output 0. Channel 1 has a low limit of 20 Ω and a high limit of 30 Ω, with digital output 1. Channel 2 has a low limit of 5 V and a high limit of 8 V, with digital output 2. Channels 3-19 have no limits and digital output set to None.

Channel	Limit	Low Limit	High Limit	Digital Output
0	<input checked="" type="checkbox"/> Enable	10 °C	100 °C	0
1	<input checked="" type="checkbox"/> Enable	20 Ω	30 Ω	1
2	<input checked="" type="checkbox"/> Enable	5 V	8 V	2
3	<input type="checkbox"/> Enable			None
4	<input type="checkbox"/> Enable			None
5	<input type="checkbox"/> Enable			None
6	<input type="checkbox"/> Enable			None
7	<input type="checkbox"/> Enable			None
8	<input type="checkbox"/> Enable			None
9	<input type="checkbox"/> Enable			None
10	<input type="checkbox"/> Enable			None
11	<input type="checkbox"/> Enable			None
12	<input type="checkbox"/> Enable			None
13	<input type="checkbox"/> Enable			None
14	<input type="checkbox"/> Enable			None
15	<input type="checkbox"/> Enable			None
16	<input type="checkbox"/> Enable			None
17	<input type="checkbox"/> Enable			None
18	<input type="checkbox"/> Enable			None
19	<input type="checkbox"/> Enable			None

If the alarm condition occurs, the specified digital output line is turned on.

To set up limit checking, do the following:

1. Under **Limit**, click the **Enable** buttons next to the channels for which you want to define limits. You can use the **Disable All** button to quickly stop limit checking on all channels. For each channel:
2. Enter a value in the **Low Limit** text box.
3. Enter a value in the **High Limit** text box.
4. (Optional) Select a **Digital Output** line to set from the drop-down list box for this channel. This line is set to 1 when the limit range (high or low) is exceeded.

When multiple channels are configured to set a digital output line, a logical OR condition exists between them, and any value out of range sets the line to 1.

5. Click **Save configuration** to apply your changes. If you do not save before leaving this page, your changes are lost.

You can also click the **Discard changes** button (before you save) to return to the previous configuration, if desired.

Digital Input and Trigger Configuration

Use the **Configuration -> Digital Input & Trigger** web page to configure the digital input lines of your instrument:

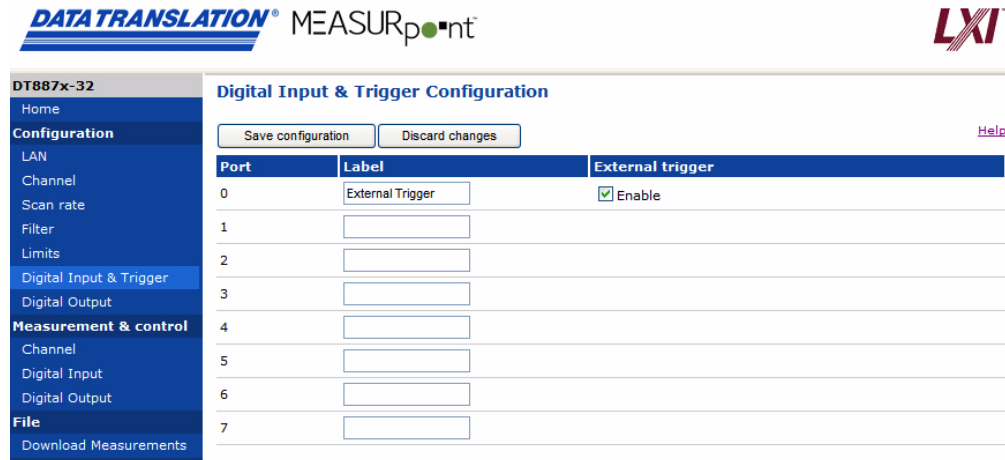

DATA TRANSLATION® MEASURpoint **LXI**

DT887x-32

Home

Configuration

LAN

Channel

Scan rate

Filter

Limits

Digital Input & Trigger

Digital Output

Measurement & control

Channel

Digital Input

Digital Output

File

Download Measurements

Digital Input & Trigger Configuration

Save configuration Discard changes [Help](#)

Port	Label	External trigger
0	External Trigger	<input checked="" type="checkbox"/> Enable
1	<input type="text"/>	<input type="checkbox"/>
2	<input type="text"/>	<input type="checkbox"/>
3	<input type="text"/>	<input type="checkbox"/>
4	<input type="text"/>	<input type="checkbox"/>
5	<input type="text"/>	<input type="checkbox"/>
6	<input type="text"/>	<input type="checkbox"/>
7	<input type="text"/>	<input type="checkbox"/>

To change your digital input configuration, do the following:

1. Describe the digital input lines, if desired, by entering text in the **Label** field corresponding to the digital input line that you want to describe.
2. To enable use of an external, digital trigger on digital input line 0, click the **Enable** checkbox under the External trigger heading.
3. Click **Save configuration** to apply your changes. If you do not save before leaving this page, your changes are lost.

You can also click the **Discard changes** button (before you save) to return to the previous configuration, if desired.

Digital Output Configuration

Use the **Configuration -> Digital Out** web page to configure the digital output lines of your instrument:

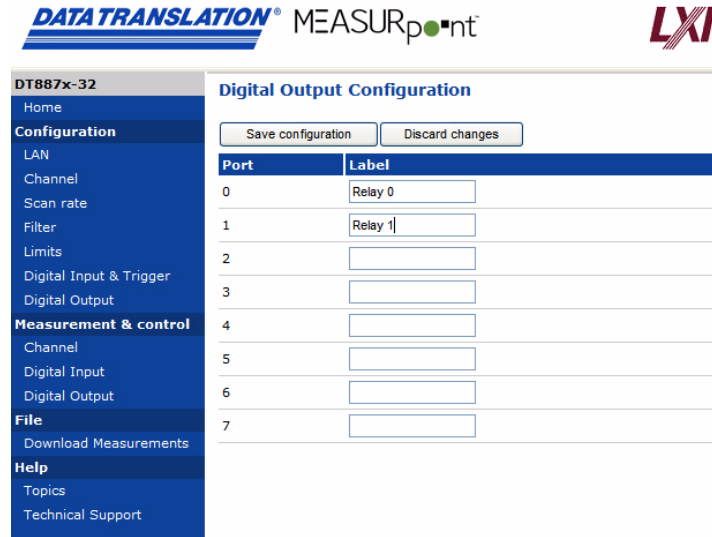

DATA TRANSLATION® MEASURpoint™ LXI

DT887x-32

Home

Configuration

LAN

Channel

Scan rate

Filter

Limits

Digital Input & Trigger

Digital Output

Measurement & control

Channel

Digital Input

Digital Output

File

Download Measurements

Help

Topics

Technical Support

Digital Output Configuration

Save configuration Discard changes

Port	Label
0	Relay 0
1	Relay 1
2	
3	
4	
5	
6	
7	

To change your digital output configuration, do the following:

1. Describe the digital output lines, if desired, by entering text in the **Label** field corresponding to the digital output line that you want to describe.
2. Click **Save configuration** to apply your changes. If you do not save before leaving this page, your changes are lost.

You can also click the **Discard changes** button (before you save) to return to the previous configuration, if desired.

Measuring Data and Controlling the Instrument

Use the Control web pages start or stop data acquisition on the sensor channels or to update the value of the digital output line.

Starting and Stopping a Scan

To start or stop a scan, use the **Measurement & control** -> **Channel** web page.

The screenshot shows the MEASURpoint web interface for a DT887x-32 instrument. The page is titled "Scan Control" and features a "Start scan" button. Below the button is a section for "Channel scan measurements" containing a grid of 48 "Meter" components, each representing a channel from Channel 0 to Channel 47. The interface also includes a navigation menu on the left and logos for DATA TRANSLATION and LXI at the top.

Press the **Start scan** button to begin acquiring data from the sensors. The measurements are displayed on the screen:

DATA TRANSLATION® MEASURpoint LXI

DT887x-32

Home

Configuration

LAN

Channel

Scan rate

Filter

Limits

Digital Input & Trigger

Digital Output

Measurement & control

Channel

Digital Input

Digital Output

File

Download Measurements

Help

Topics

Technical Support

Scan Control

Stop scan Scanning at 7.500000 Hz

Channel scan measurements

Meter

Channel 40	Channel 41	Channel 42	Channel 43	Channel 44	Channel 45	Channel 46	Channel 47
Channel 32	Channel 33	Channel 34	Channel 35	Channel 36	Channel 37	Channel 38	Channel 39
Channel 24	Channel 25	Channel 26	Channel 27	Channel 28	Channel 29	Channel 30	Channel 31
Channel 16	Channel 17	Channel 18	Channel 19	Channel 20	Channel 21	Channel 22	Channel 23
Thermocouple 0	Thermocouple 1	Channel 10	Channel 11	Channel 12	Channel 13	Channel 14	Channel 15
RTD 0	Resistance	Furnace	Channel 3	Channel 4	Channel 5	Channel 6	Channel 7

800.00 V 925.00 V 970.00 V 1015.00 V 1060.00 V 1105.00 V 1150.00 V 1195.00 V

520.0 °C 565.00 V 610.00 V 655.00 V 700.00 V 745.00 V 790.00 V 835.00 V

160.0 °C 205.0 °C 250.0 °C 295.0 °C 340.0 °C 385.0 °C 430.0 °C 475.00 V

0.0 °C -155.0 Ω -110.00 V -65.00 V -20.00 V 25.00 V 70.00 V 115.00 V

Notice the following aspects of the display:

- When acquiring data, the **Start scan** button changes to say **Stop scan** and the currently configured scan rate is displayed.
- Each box on the Meter tab represents one of the analog input channels, in the same position as the physical connectors.
- If you configured custom labels for some of the channels, those labels are shown here rather than the channel numbers.
- Red boxes indicate that the value is out of range for the specified sensor type.
- The values are updated only for the channels that you enabled, and at the scan rate you configured.

Press the **Stop scan** button to stop acquiring data from the sensors.

Controlling the Digital Outputs

Use the **Measurement & control** -> **Digital Output** web page to view the current state of the digital output lines, and manually change them if desired. A screen similar to the following appears:

DATA TRANSLATION MEASURpoint **LXI**

T887x-32

Home

Configuration

LAN

Channel

Scan rate

Filter

Limits

Digital Input & Trigger

Digital Output

Measurement & control

Channel

Digital Input

Digital Output

File

Download Measurements

Help

Topics

Technical Support

Digital Output Status and Control

Port	Label	Current state	New state
0		Closed	<input type="button" value="Open"/>
1		Closed	<input type="button" value="Open"/>
2		Closed	<input type="button" value="Open"/>
3		Open	<input type="button" value="Close"/>
4		Open	<input type="button" value="Close"/>
5		Open	<input type="button" value="Close"/>
6		Open	<input type="button" value="Close"/>
7		Open	<input type="button" value="Close"/>

Green indicates that the digital output line/relay is closed; red indicates that the digital output line/relay is open.

Note: You cannot change the configuration of digital output lines that were configured for limit checking on the **Configuration** -> **Limits** page.

To change the status of a digital output line/relay, click the **Open/Close** toggle buttons under the **Change State** heading for the digital output lines that you want to change. You can use these controls to activate or deactivate an external device based on criteria other than temperature that you define.

Reading the Digital Inputs

While the instrument is scanning, you can use the **Measurement & control** -> **Digital Input** web page to view the current value of the digital input port. A screen similar to the following appears:

The screenshot shows the MEASURpoint web interface for a DT887x-32 instrument. The left sidebar contains a navigation menu with categories: DT887x-32, Configuration, Measurement & control, File, and Help. The main content area is titled 'Digital Input Status' and contains a table with the following data:

Port	Label	Current state
0		Open
1		Open
2		Open
3		Open
4		Open
5		Open
6		Open
7		Open

If you configured custom labels for the digital input lines, those labels are shown here.

The **Current state** LEDs show green if the digital input line is on (relay is closed) or red if the digital input line is off (relay is open).

Downloading Measurements

Note: Before using this feature, ensure that you have associated CSV files with Microsoft Excel or Notepad, described on [page 71](#), or the data will be displayed in the browser and not saved to a file.

You can use the **File -> Download Measurements** web page to download your measurement results, including timestamp and limit values, if applicable, to disk. A screen similar to the following appears:

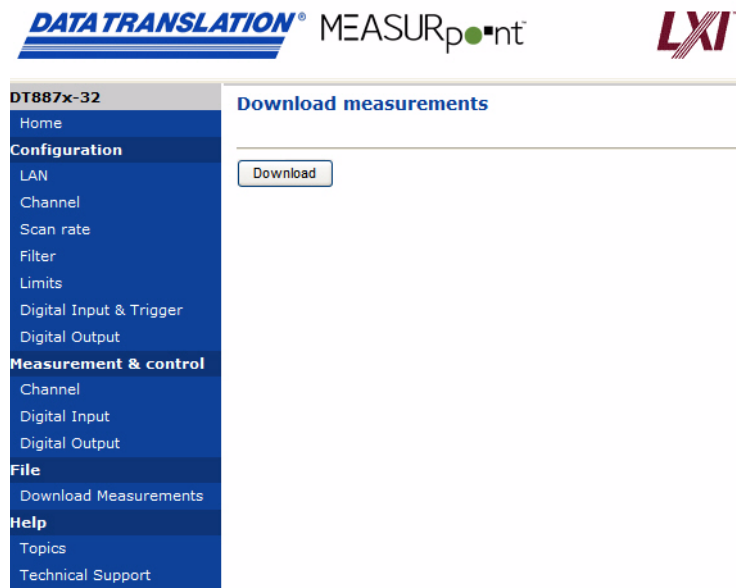

Measurements taken by the instrument are stored in a large circular buffer; when the buffer is full, the oldest data is overwritten with the most recent data.

To download your data, do the following:

1. Click the **Download** button on this page.

If scanning has been stopped, all the data in the buffer is downloaded to a comma-separated CSV file, starting with the most recent data.

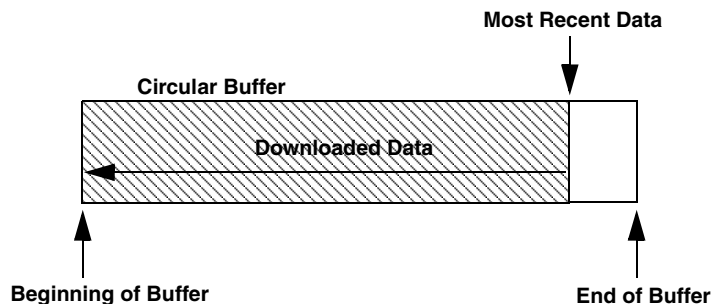

If scanning is in progress, a snapshot of the data from the most recent data (at the time that the **Download** button was clicked) to the oldest data in the buffer is downloaded to a comma-separated CSV file.

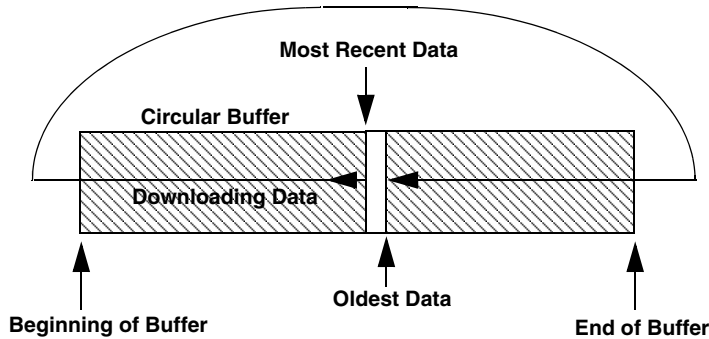

2. In the resulting dialog box, choose **Open** or **Save**.

- If you choose **Open**, the CSV file opens in the associated application (Microsoft Excel or Notepad).
- If you choose **Save**, you can open the CSV file in Microsoft Excel, Notepad, or other utilities for analysis at a later time.

Under some circumstances, your data may be displayed in a frame in the browser, or Excel may open the data in the frame; an example follows:

DATA TRANSLATION® MEASURpoint **LXI**

DT887x-32		B1		10.0 Hz							
Home		A	B	C	D	E	F	G	H	I	
Configuration	1	Scan rate	10.0 Hz								
LAN	2			RTD 0	RTD 0	Resistance	Resistance	Furnace	Furnace		
Channel	3	Scan#	Date	Time	chan 0	chan 0	chan 1	chan 1	chan 2	chan 2	
Scan rate	4				C	limit	ohm	limit	V	limit	
Filter	5	7491	4/28/2009	15:54:06	high value	hi	1810.31	hi	0.260711	lo	
Limits	6	7490	4/28/2009	15:54:06	high value	hi	1810.31	hi	0.267423	lo	
Digital Input & Trigger	7	7489	4/28/2009	15:54:05	high value	hi	1810.31	hi	0.274077	lo	
Digital Output	8	7488	4/28/2009	15:54:05	high value	hi	1810.31	hi	0.280672	lo	
Measurement & control	9	7487	4/28/2009	15:54:05	high value	hi	1810.31	hi	0.287209	lo	
Channel	10	7486	4/28/2009	15:54:05	high value	hi	1810.32	hi	0.293686	lo	
Digital Input	11	7485	4/28/2009	15:54:05	high value	hi	1810.32	hi	0.300115	lo	
Digital Output	12	7484	4/28/2009	15:54:05	high value	hi	1810.32	hi	0.30649	lo	
File	13	7483	4/28/2009	15:54:05	high value	hi	1810.32	hi	0.312813	lo	
Download Measurements	14	7482	4/28/2009	15:54:04	high value	hi	1810.31	hi	0.319089	lo	
Help	15	7481	4/28/2009	15:54:04	high value	hi	1810.31	hi	0.325323	lo	
Topics	16	7480	4/28/2009	15:54:04	high value	hi	1810.31	hi	0.331514	lo	
Technical Support	17	7479	4/28/2009	15:54:04	high value	hi	1810.31	hi	0.337672	lo	
	18	7478	4/28/2009	15:54:04	high value	hi	1810.31	hi	0.343796	lo	
	19	7477	4/28/2009	15:54:04	high value	hi	1810.31	hi	0.349896	lo	
	20	7476	4/28/2009	15:54:04	high value	hi	1810.31	hi	0.355969	lo	
	21	7475	4/28/2009	15:54:04	high value	hi	1810.32	hi	0.362019	lo	
	22	7474	4/28/2009	15:54:03	high value	hi	1810.32	hi	0.368049	lo	
	23	7473	4/28/2009	15:54:03	high value	hi	1810.32	hi	0.374063	lo	
	24	7472	4/28/2009	15:54:03	high value	hi	1810.32	hi	0.380055	lo	
	25	7471	4/28/2009	15:54:03	high value	hi	1810.32	hi	0.386026	lo	
	26	7470	4/28/2009	15:54:03	high value	hi	1810.31	hi	0.391974	lo	
	27	7469	4/28/2009	15:54:03	high value	hi	1810.31	hi	0.397989	lo	
	28	7468	4/28/2009	15:54:03	high value	hi	1810.32	hi	0.403771	lo	

Change your Microsoft Excel, Microsoft Explorer, and Internet Explorer settings to turn off these behaviors and open your files directly in Excel.

Part 2: Using Your Instrument



Principles of Operation

Block Diagrams	94
Analog Input Features	99
Digital I/O Features	110

Block Diagrams

This section includes the block diagrams for the DT8871U, DT8871, and DT8872 TEMPpoint instruments, DT8873 VOLTpoint instrument, and DT8874 MEASURpoint instruments.

DT8871U Block Diagram

Figure 26 shows the block diagram of the DT8871U TEMPpoint instrument.

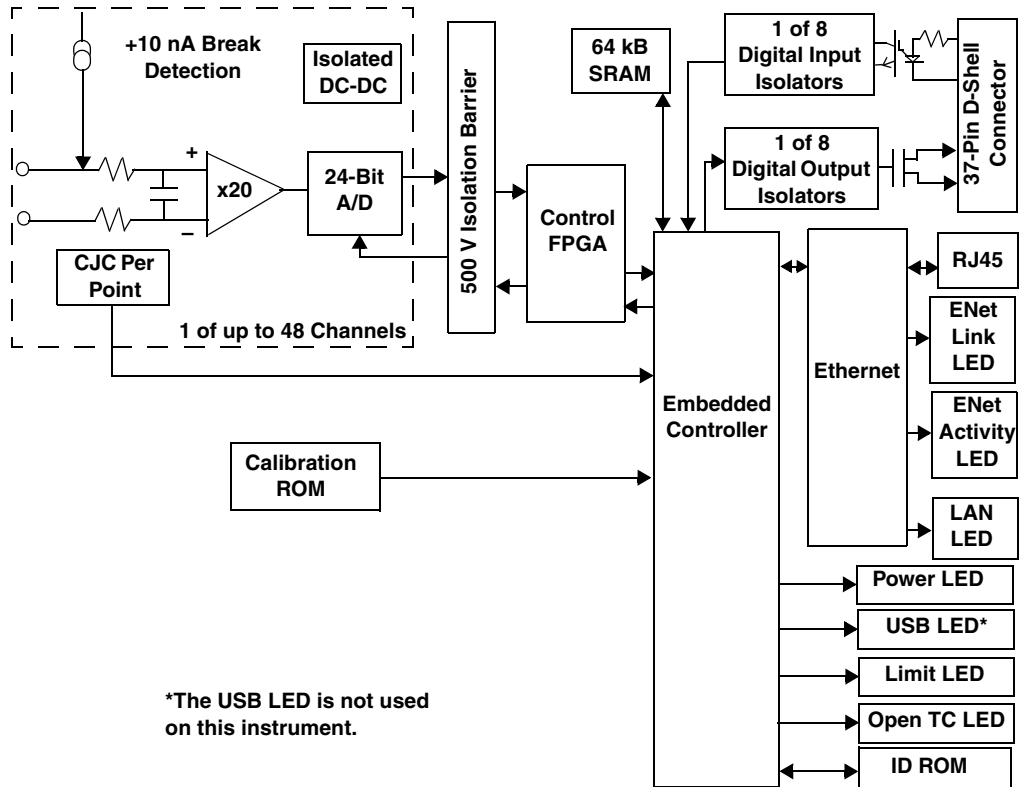

Figure 26: Block Diagram of the DT8871U TEMPpoint Instrument

DT8871 Block Diagram

Figure 27 shows the block diagram of the DT8871 instrument.

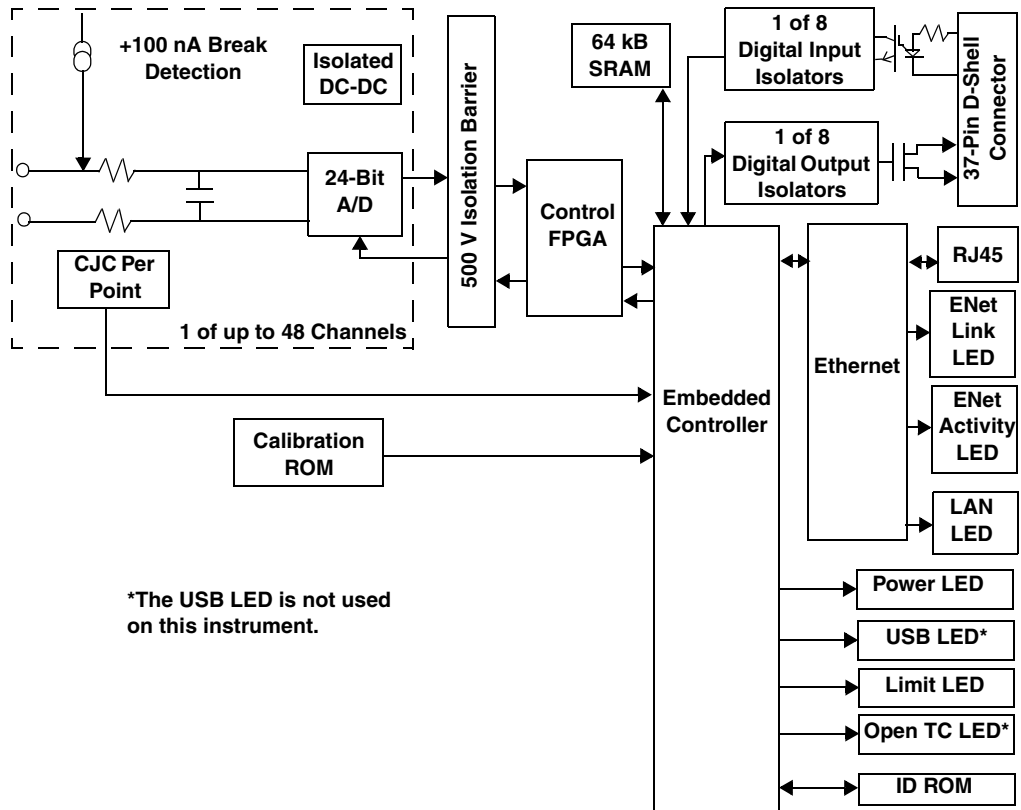

Figure 27: Block Diagram of the DT8871 TEMPpoint Instrument

DT8872 Block Diagram

Figure 28 shows the block diagram of the DT8872 TEMPpoint instrument.

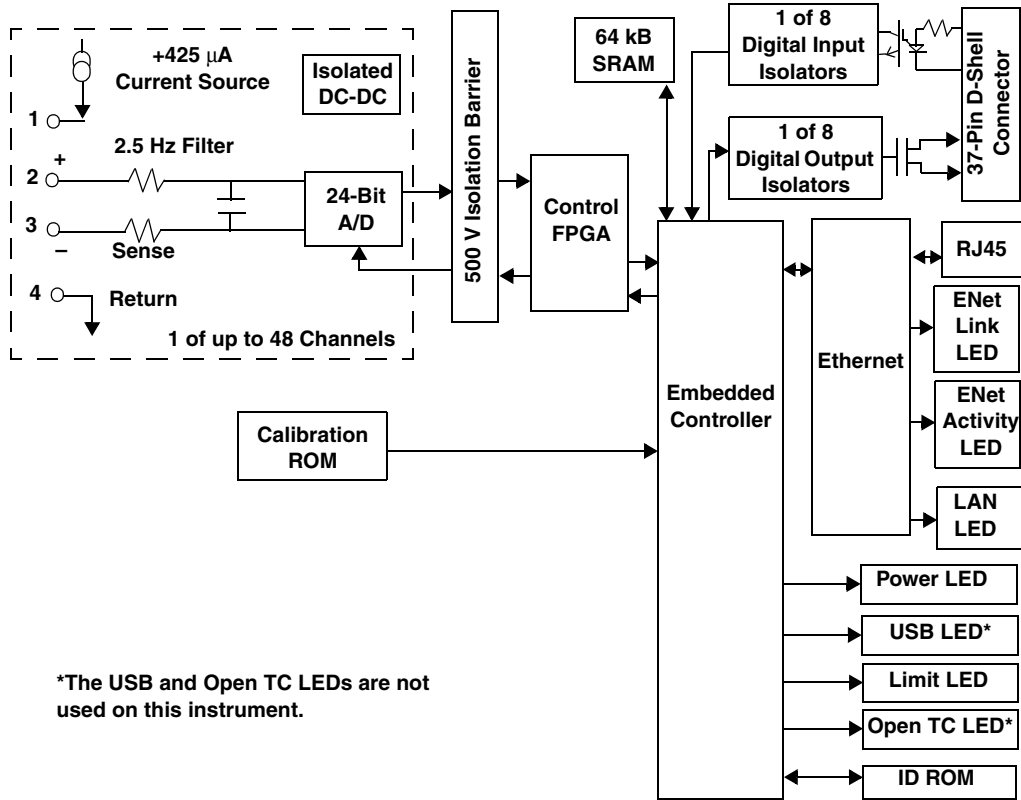

Figure 28: Block Diagram of the DT8872 TEMPpoint Instrument

DT8873 Block Diagram

Figure 29 shows the block diagram of the DT8873 VOLTpoint instrument.

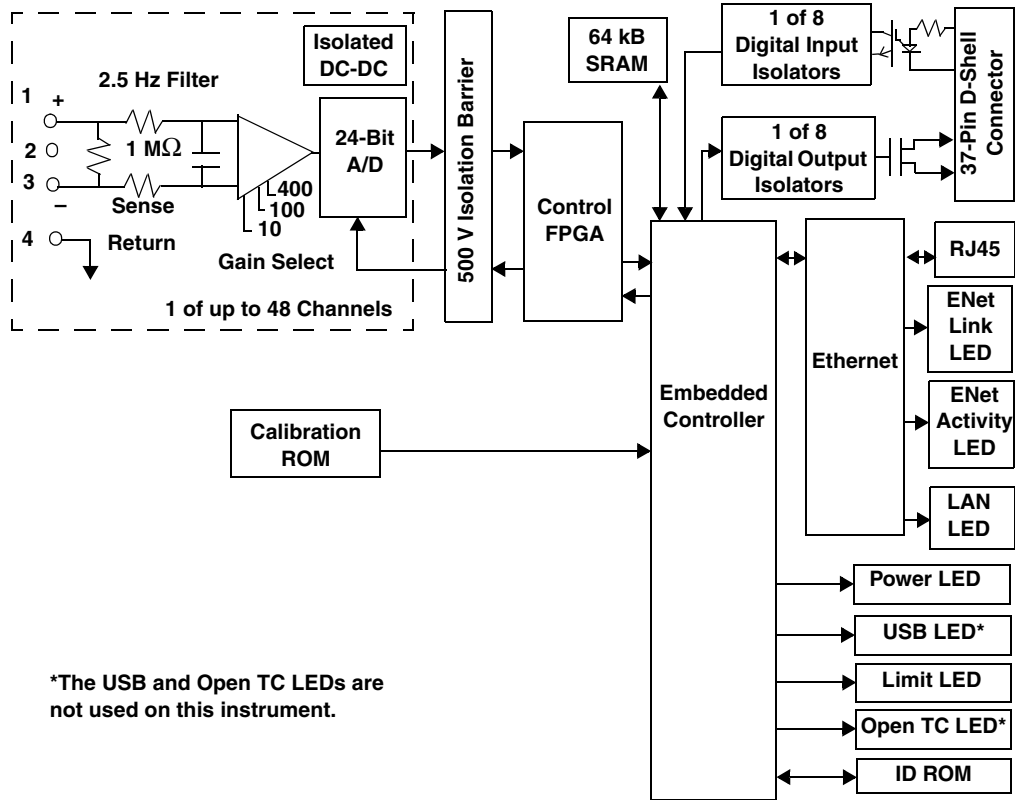

Figure 29: Block Diagram of the DT8873 VOLTpoint Instrument

DT8874 Block Diagram

Figure 30 shows the block diagram of the DT8874 MEASURpoint instrument.

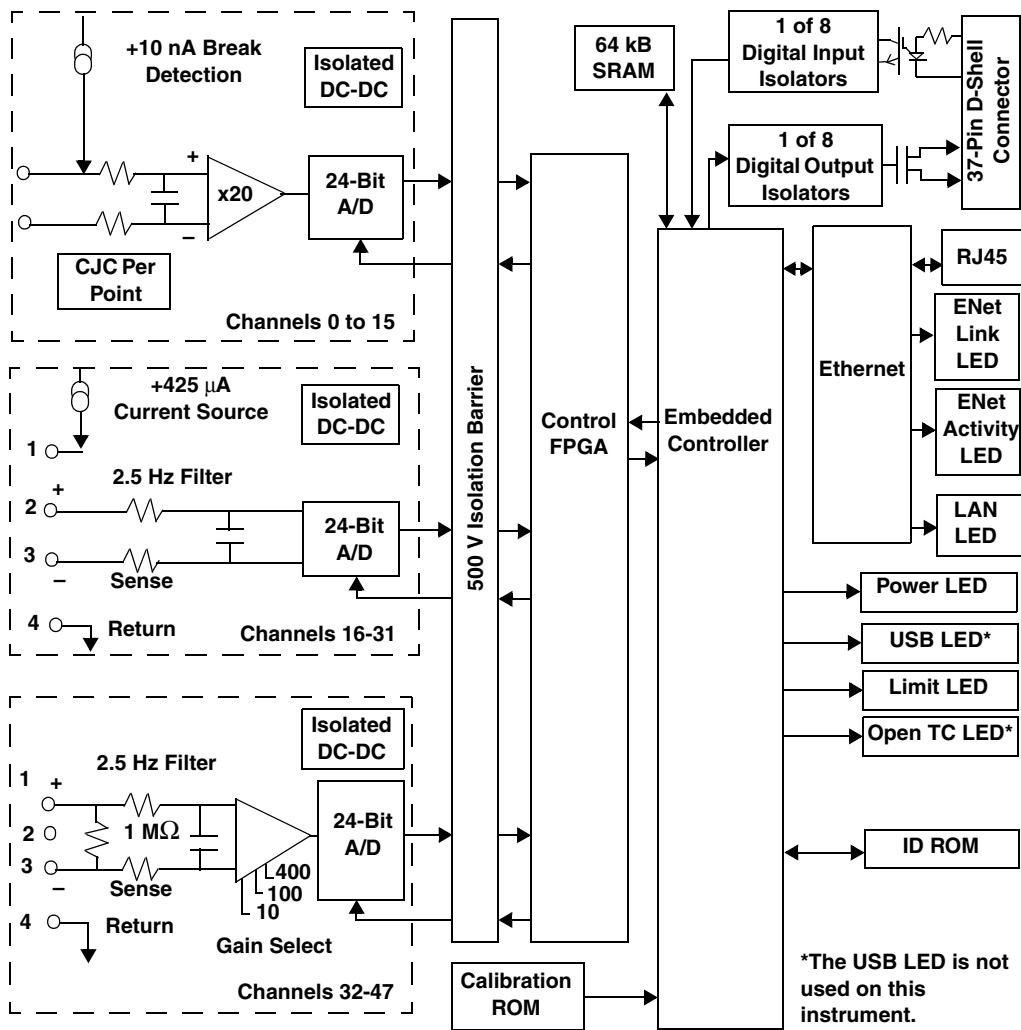

Figure 30: Block Diagram of the DT8874 MEASURpoint Instrument

Analog Input Features

This section describes the following features of the analog input (A/D) subsystem on TEMPpoint, VOLTpoint, and MEASURpoint instruments:

- Analog input channels, described on this page
- Input ranges, described on [page 102](#)
- Resolution, described on [page 104](#)
- Calibration, described on [page 104](#)
- Sample clock, described on [page 105](#)
- Trigger source, described on [page 105](#)
- Conversion modes, described on [page 105](#)
- Filtering, described on [page 107](#)
- Data format, described on [page 108](#)
- Error conditions, described on [page 108](#)

Analog Input Channels

TEMPpoint, VOLTpoint, and MEASURpoint instruments provide up to 48 analog input channels. The number of channels and the channel types supported (thermocouple, RTD, or voltage input) depend on the specific instrument model you purchased, as shown in [Table 3](#).

Table 3: Number and Type of Analog Input Channels

Instrument Type	Models	# of Analog Input Channels	Channel Types
TEMPpoint	DT8871U-8 and DT8871-8	8	8 thermocouple inputs (numbered 0 to 7)
	DT8871U-16 and DT8871-16	16	16 thermocouple inputs (numbered 0 to 15)
	DT8871U-24 and DT8871-24	24	24 thermocouple inputs (numbered 0 to 23)
	DT8871U-32 and DT8871-32	32	32 thermocouple inputs (numbered 0 to 31)
	DT8871U-40 and DT8871-40	40	40 thermocouple inputs (numbered 0 to 39)
	DT8871U-48 and DT8871-48	48	48 thermocouple inputs (numbered 0 to 47)
	DT8872-8	8	8 RTD inputs (numbered 0 to 7)
	DT8872-16	16	16 RTD inputs (numbered 0 to 15)
	DT8872-24	24	24 RTD inputs (numbered 0 to 23)
	DT8872-32	32	32 RTD inputs (numbered 0 to 31)
	DT8872-40	40	40 RTD inputs (numbered 0 to 39)
	DT8872-48	48	48 RTD inputs (numbered 0 to 47)

Table 3: Number and Type of Analog Input Channels (cont.)

Instrument Type	Models	# of Analog Input Channels	Channel Types
VOLTpoint	DT8873-8	8	8 high voltage inputs (numbered 0 to 7)
	DT8873-16	16	16 high voltage inputs (numbered 0 to 15)
	DT8873-24	24	24 high voltage inputs (numbered 0 to 23)
	DT8873-32	32	32 high voltage inputs (numbered 0 to 31)
	DT8873-40	40	40 high voltage inputs (numbered 0 to 39)
	DT8873-48	48	48 high voltage inputs (numbered 0 to 47)
MEASURpoint	DT8874-16T-16R-16V	48	16 thermocouple inputs (numbered 0 to 15)
			16 RTD inputs (numbered 16 to 31)
			16 high voltage inputs (numbered 32 to 47)

Thermocouple Input Channels

For channels that support thermocouples, you can attach a voltage input or any of the following thermocouple types in a mix and match fashion: B, E, J, K, N, R, S, and/or T.

By default, these channels are configured for voltage inputs. You can specify the thermocouple types for channels over the LAN using the web interface, as described in [“Channel Configuration” on page 79](#), in software using the Change Configuration dialog in the supplied Measurement Application, or by using an API call in your application program. You can also use standard SCPI commands over VISA or sockets, if desired.

Note: In a mix-and-match system, it is easy to accidentally mismatch the software and hardware configuration for a channel. Therefore, it is recommended that you pay particular attention when configuring channels, since the resultant errors may be not large enough to notice initially, but may be significantly larger than the accuracy specification for the instrument.

Since each channel has its own 24-bit A/D, analog inputs are measured simultaneously. Refer to [page 105](#) for more information on specifying the channels for a scan.

[Table 4](#) lists the supported measurement range for each thermocouple type. (Refer to [page 102](#) for information on the supported input range for voltage measurements.)

Table 4: Supported Measurement Range for Each Thermocouple Type

Thermocouple Type	Supported Measurement Range	
	Minimum	Maximum
B	0° C (32° F)	1820° C (3308° F)
E	-200° C (-328° F)	1000° C (1832° F)
J	-210° C (-346° F)	1200° C (2192° F)
K	-200° C (-328° F)	1370° C (2498° F)
N	-200° C (-328° F)	1300° C (2372° F)
R	-50° C (-58° F)	1750° C (3182° F)
S	-50° C (-58° F)	1750° C (3182° F)
T	-200° C (-328° F)	400° C (752° F)

Refer to [Appendix A](#) for the thermocouple accuracy of thermocouple channels over the dynamic range of the instrument.

Cold Junction Compensation

Each thermocouple channel has its own cold-junction compensation (CJC) at the input. The software reads the value of the CJC input along with the value of the analog input channel and automatically corrects for errors based on the specified thermocouple type and the thermocouple linearization data stored in onboard ROM.

A separate multiplexed A/D is used to acquire all the CJC input values. The software takes care of correlating the CJC measurements with the analog input measurements.

Note: The software provides the option of returning CJC values in the data stream. This option is seldom used, but is provided if you want to implement your own temperature conversion algorithms in software when using continuous operations. Refer to [page 108](#) for more information on this feature.

Open Thermocouple Detection

Break detection circuitry (+10 nA on the DT8871U and DT8874; +100 nA on the DT8871) is provided for thermocouple channels to ensure that open thermocouples are detected. The Open (OPN) LED on the rear panel lights when this condition occurs; see [Figure 8 on page 43](#) for the location of this LED.

In addition, the software returns the value `SENSOR_IS_OPEN` (99999 decimal) for any channel that was configured for a thermocouple input and has either an open thermocouple or no thermocouple connected to it. This value is returned anytime a voltage greater than 100 mV is measure on the input, since this value is greater than any legitimate thermocouple voltage.

If the channel is configured for a voltage input (not a thermocouple type), the Open (OPN) LED never lights and the `SENSOR_IS_OPEN` value is not returned. Instead, the voltage value is returned. If no input is connected to the channel, the software returns a value of approximately 0.7 V due to the open thermocouple detection pull-up circuit.

RTD Channels

For channels that support RTDs, you can attach a voltage input or any of the following RTD types in a mix and match fashion: Platinum 100 Ω (Pt100), Platinum 500 Ω (Pt500), or Platinum 1000 Ω (Pt1000) RTD using an European alpha curve of 0.00385 or an American alpha curve of 0.00392. The supported temperature measurement range for these RTD types is -200°C (-328°F) to 850°C (1562°F). You can also measure a resistance value between 0 and 4k Ohms, if desired. (Refer to [page 102](#) for information on the supported input range for voltage measurements.)

By default, all channels are configured for voltage inputs. You can specify the RTD types for channels over the LAN using the web interface, as described in “[Channel Configuration](#)” on [page 79](#), in software using the Change Configuration dialog in the supplied Measurement Application, or by using an API call in your application program. You can also use standard SCPI commands over VISA, if desired.

Note: In a mix-and-match system, it is easy to accidentally mismatch the software and hardware configuration for a channel. Therefore, it is recommended that you pay particular attention when configuring channels, since the resultant errors may be not large enough to notice initially, but may be significantly larger than the accuracy specification for the instrument.

Since each channel has its own 24-bit A/D, analog inputs are measured simultaneously. Refer to [page 105](#) for more information on specifying the channels for a scan.

Input Ranges

The input voltage range that is supported by your TEMPpoint, VOLTpoint, or MEASURpoint instrument depends on the specific instrument model that you purchased, as shown in [Table 5](#).

Table 5: Supported Input Ranges

Instrument Type	Models	Input Range
TEMPpoint	DT8871U	± 0.75 V for all channels
	DT8871	± 1.25 V for all channels
	DT8872	± 1.25 V for all channels
VOLTpoint	DT8873	± 10 V, ± 100 V, or ± 400 V (software-selectable for each channel) ^a
MEASURpoint	DT8874-16T-16R-16V	± 0.75 V for channels 0 to 15; ± 1.25 V for channels 15 to 31; ± 10 V, ± 100 V, or ± 400 V for channels 32 to 47 (software-selectable for each channel)

a. Older versions of this instrument had fixed input ranges of ± 10 V, ± 100 V, or ± 400 V, depending on the model purchased.

Out of Range Data for Thermocouple Channels

Each thermocouple type corresponds to an allowable voltage range. If a voltage is measured on the input that is outside of the legal range for the selected thermocouple type, the channel may be configured for the wrong type of thermocouple or something other than a thermocouple may be connected to the channel.

For channels configured with a thermocouple type of None (voltage), the Limit (LMT) LED on the rear panel of the instrument lights to alert you when the voltage is out of range; see [Figure 8 on page 43](#) for the location of this LED.

For channels configured with a thermocouple type other than None (voltage), the LMT LED lights when the temperature limit is out of range for the specified thermocouple type.

In addition, if the input voltage is less than the legal voltage range for the selected thermocouple type, the software returns the value TEMP_OUT_OF_RANGE_LOW (-88888 decimal). If the input voltage is greater than the legal voltage range for the selected thermocouple type, the software returns the value TEMP_OUT_OF_RANGE_HIGH (88888 decimal).

Note: If you are continuously measuring from a properly configured thermocouple input channel and the thermocouple opens or becomes disconnected, the open thermocouple pull-up circuit causes the input voltage to rise to approximately 0.7 V over a few seconds.

In this case, the temperature value rises very quickly, and you will receive the TEMP_OUT_OF_RANGE_HIGH (88888 decimal) value followed by the OPEN_SENSOR (99999 decimal) value. In this case, the OPN LED lights when the open thermocouple is detected and the LMT LED lights when the temperature limit is out of range for the thermocouple type.

Out of Range Data for RTD Channels

Each RTD type corresponds to an allowable voltage range. If a voltage is measured on the input that is outside of the legal range for the selected RTD type, the channel may be configured for the wrong type of RTD or something other than an RTD may be connected to the channel.

For channels configured with a RTD type of voltage, the Limit (LMT) LED on the rear panel of the instrument lights to alert you when the voltage is out of range (greater than +1.25 V or less than -1.25 V); see [page 43](#) for the location of this LED. For channels configured with an RTD type other than voltage, the LMT LED lights when the temperature limit is out of range for the specified RTD type.

In addition, if the input voltage is less than the legal voltage range for the selected RTD type, the software returns the value TEMP_OUT_OF_RANGE_LOW (-88888.0 decimal). If the input voltage is greater than the legal voltage range for the selected RTD type, the software returns the value TEMP_OUT_OF_RANGE_HIGH (88888.0 decimal).

Out of Range Data for High Voltage Channels

Each voltage input channel has an allowable voltage range (± 10 V, ± 100 V, or ± 400 V). You configure the input range for each channel using software. If a voltage is measured on the input that is outside of the legal range for that channel, the Limit (LMT) LED on the rear panel of the instrument lights to alert you; see [page 43](#) for the location of this LED.

Resolution

TEMPpoint, VOLTpoint, and MEASURpoint instruments support a resolution of 24 bits for the analog input subsystem; you cannot specify the resolution in software.

Calibration

Each TEMPpoint, VOLTpoint, and MEASURpoint instrument is factory-calibrated to meet or exceed its published specifications using standards traceable to NIST.

The calibration process includes multiple steps. First, the A/D on each channel is calibrated for offset and gain; these values (including the zero point) are stored in ROM. Then, each CJC circuit is calibrated for thermocouple input channels, and the reference current is characterized for RTD channels.

While each instrument was designed to preserve high accuracy measurements over time, it is recommended that your instrument be recalibrated every year to ensure that it meets or exceeds specifications.

You can calibrate your instrument in the field using precise calibration equipment and the Measurement Instrument Calibration Utility, described on [page 21](#). Optionally, you can return your instrument to Data Translation for recalibration. For information on factory recalibration, contact Data Translation at 508-481-3700, ext. 1323 (if you are in the USA) or call your local distributor (if you are located outside the USA); see our web site (www.datatranslation.com) for the name and telephone number of your nearest distributor.

In addition, each instrument auto-calibrates on each power-up cycle to guarantee high-accuracy measurements. This process, also known as auto-zeroing, resets the zero point of each A/D. You can also auto-calibrate the instrument at any time (as long as acquisition is not in progress) using a software command. Refer to your software documentation for more information on the auto-calibration feature.

Sample Clock Source

TEMPpoint, VOLTpoint, and MEASURpoint instruments support an internal clock with a maximum sampling rate of 10 Samples/s.

Use software to specify an internal clock source and a clock frequency between 0.000152590219 Hz and 10.0 Hz.

Note: The clock frequency that you specify is rounded to the closest "correct" value that the instrument can accept without error. Internally, the 10 Hz clock is divided by an integer in the range of 1 to 65535 (the internal clock divider) to determine the closest value. Using software, you can query this setting to determine the actual clock frequency that is used.

When the continuous operation is started, all the channels specified in the channel list are read simultaneously at the specified clock frequency.

Trigger Source

A trigger is an event that occurs based on a specified set of conditions. Acquisition starts when the instrument detects the initial trigger event and stops when you stop the operation.

TEMPpoint, VOLTpoint, and MEASURpoint instruments support the following trigger sources for starting analog input operations:

- **Software trigger** – A software trigger event occurs when you start the analog input operation (the computer issues a write to the instrument to begin conversions).
- **External digital trigger** – An external digital trigger event occurs when the instrument detects a voltage from +3 V to +28 V DC on digital input line 0. Initially, the external signal must be low and then go high for at least 100 ms to be detected as a trigger. Once triggered, the state of digital input 0 is ignored.

Conversion Modes

TEMPpoint, VOLTpoint, and MEASURpoint instruments support simultaneous single value and continuous scan conversion modes for reading input measurements.

This section describes each of these conversion modes.

Simultaneous Single-Value Operations

If you want a snapshot of all the analog input channels at one point in time, you can perform a simultaneous single-value operation, also called a single values operation, using SCPI commands.

Note: This operation mode is supported in SCPI only; it is not supported by the IVI-COM driver or the instrument's web interface.

Use one of the **:MEASure** SCPI commands to specify the channels that you want to sample and the configuration of the channels, if needed. One single value is then acquired from each analog input channel simultaneously and returned.

If you need to continuously acquire data from one or more channels use continuous scan mode, described next, instead.

Continuous Scan Mode

Continuous scan mode takes full advantage of the capabilities of the TEMPpoint, VOLTpoint, and MEASURpoint instruments. Use continuous scan mode if you want to accurately control the period between successive simultaneous conversions of specific channels.

In addition to the analog input channels, this conversion mode allows you to read the digital input port (all 8 digital input lines) as part of the analog input data stream. This feature is particularly useful when you want to correlate the timing of analog and digital events.

Specifying Analog Input Channels

Using software, enable the analog input channels that you want to sample by specifying the channel numbers in the channel list. You can also read the value of the digital input port through the analog input data stream by specifying the digital input channel in the channel list; the number of the digital input channel depends on how many channels the TEMPpoint, VOLTpoint, or MEASURpoint instrument provides, as shown in [Table 6](#).

Table 6: Supported Channels for Continuous Operations

Total Number of Analog Input Channels	Channel for Reading the Digital Input Port
0 to 7	8
0 to 15	16
0 to 23	24
0 to 31	32
0 to 39	40
0 to 47	48

The channels are read in order from the lowest channel number to the highest channel number in the list of enabled channels; this process is known as a scan.

How Continuous Scan Works

When you issue a command to start the scan, the instrument simultaneously samples all the analog input channels, CJC inputs (if applicable), and the digital input port, and converts the analog inputs to temperature, resistance, or voltage based on the sensor type. If the channel is enabled, the sampled data is placed in the FIFO on the instrument.

The FIFO on the instrument is used as a circular buffer. Acquisition continues indefinitely until you stop the operation. When the FIFO is full, the operation wraps to the beginning of the FIFO; values are overwritten starting at the first location in the FIFO. It is up to your application to retrieve the data from the FIFO; refer to your software documentation for more information.

The conversion rate is determined by the frequency of the input sample clock; refer to [page 105](#) for more information about the input sample clock. The sample rate, which is the rate at which a single entry in the channel list is sampled, is the same as the conversion rate due to the simultaneous nature of the MEASURpoint instrument.

[Figure 31](#) illustrates scanning a list of three enabled channels: channel 0, channel 1, and channel 2. In this example, analog input data is acquired simultaneously on each clock pulse of the input sample clock. Data is acquired continuously.

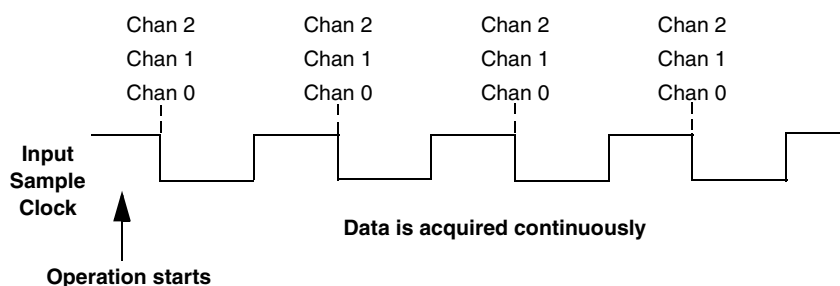

Figure 31: Continuous Scan Mode

Filtering

TEMPpoint, VOLTpoint, and MEASURpoint instruments use a Delta-Sigma analog-to-digital converter (ADC) for each analog input channel to provide simultaneous sampling of all inputs. The Delta-Sigma converter operates at 10 Hz effectively providing a filter that rejects 50 Hz and 60 Hz power line frequency components and that removes *aliasing*, a condition where high frequency input components erroneously appear as lower frequencies after sampling.

In addition to the filter provided in hardware, you can further reduce noise by selecting one of the following filter options in software: Moving Average or Raw. Refer to [page 81](#) and to your software documentation for more information on selecting a filter type.

Data Format

TEMPpoint, VOLTpoint, and MEASURpoint instruments return data as 32-bit floating-point values. How the data is returned depends on the channel type, as described in the following subsections.

Data Format for Thermocouple Channels

If you specify a thermocouple type of None for a thermocouple input channel, a voltage measurement is selected and the instrument returns a voltage value. For the DT8871U and DT8874 instruments, the value is in the range of ± 0.075 V; for the DT8872 instrument, the value is in the range of ± 1.25 V. For all other thermocouple types, a temperature value, in degrees C, or one of the error constants, described on [page 109](#), is returned.

In normal operation, one floating-point value is returned for each enabled channel (including the digital input port). If you enable the capability of returning CJC data in the data stream, described on [page 101](#), two floating-point values are returned in the data stream for each enabled analog input channel. The first value in the pair represents the temperature (or voltage) of the channel; the second value in the pair represents the CJC temperature (in degrees C) for that channel.

Data Format for RTD Channels

If you specify an RTD type of None for an RTD input channel, a voltage measurement is selected and the instrument returns a voltage value in the range of ± 1.25 V. If you specify an RTD type of Ohms, a resistance value is returned. For all other RTD types, a temperature value, in degrees C, or one of the error constants, described on [page 109](#), is returned.

One floating-point value is returned for each enabled channel (including the digital input port).

Data Format for High Voltage Channels

For high voltage channels, a voltage value in the range of ± 10 V, ± 100 V, or ± 400 V is returned, depending on how the channel was configured.

One floating-point value is returned for each enabled channel (including the digital input port).

Error Conditions

TEMPpoint, VOLTpoint, and MEASURpoint instruments report overrun errors by sending an overrun event to the application program. If this error condition occurs, the instrument stops acquiring and transferring data to the host computer. To avoid this error, try one or more of the following:

- Reduce the sample rate
- Close any other applications that are running
- Run the program on a faster computer

Additionally, the following constants may be reported to the host:

- 99999.0 – SENSOR_IS_OPEN, described on [page 101](#)
- 88888.0 – TEMP_OUT_OF_RANGE_HIGH, described on [page 103](#) and [page 104](#)
- -88888.0 – TEMP_OUT_OF_RANGE_LOW, described on [page 103](#) and [page 104](#)

If any of these constants is reported, the A/D subsystem continues to acquire data; the error condition is cleared when the data falls within range.

Digital I/O Features

TEMPpoint, VOLTpoint, and MEASURpoint instruments provide 8 digital input lines and 8 digital output lines that you can use to control external equipment, including solid-state or mechanical relays.

This section describes the following digital I/O features:

- Digital input lines, described below
- Digital output lines, described on [page 111](#)
- Channel-to-channel isolation, described on [page 111](#)
- Resolution, described on [page 111](#)
- Operation modes, described on [page 111](#)

Digital Input Lines

TEMPpoint, VOLTpoint, and MEASURpoint instruments feature eight, isolated, digital input lines.

Digital inputs operate from +3 to +28 V DC, with a switching time of 2 ms maximum. [Figure 32](#) shows the digital input circuitry; a 2.2 k Ω resistor is used in series with the LED in the opto-isolator input.

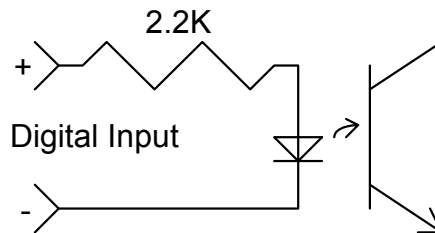

1 of 8 Opto-Isolators

Figure 32: Digital Input Circuitry

A digital line is high (switch is closed) if its value is 1; a digital line is low (switch is open) if its value is 0.

Digital Output Lines

TEMPpoint, VOLTpoint, and MEASURpoint instruments feature eight, latched and isolated digital output lines. The outputs are solid-state relays that operate at ± 30 V and 400 mA peak (AC or DC). Switching time is 2 ms maximum.

Figure 33 shows the digital output circuitry.

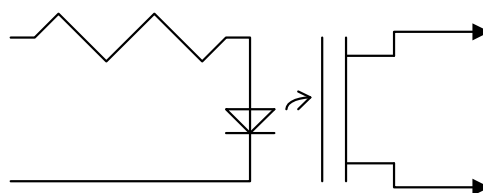

1 of 8 Solid State Relays

Figure 33: Digital Output Circuitry

Digital outputs resemble a switch; the switch is closed if the state of the digital output line is 1, and the switch is open if the state of the digital output line is 0. On power up or reset, the digital outputs are disabled.

Channel-to-Channel Isolation

Each TEMPpoint, VOLTpoint, and MEASURpoint instrument includes channel-to-channel isolation of up to 250 V between digital I/O lines. If you require greater channel-to-channel isolation, use every other digital line. This reduces the number of digital I/O lines, but provides channel-to-channel isolation of 500 V (one channel can be +250 V while the adjacent channel can be -250 V).

Resolution

Each TEMPpoint, VOLTpoint, and MEASURpoint instrument provides 8 bits of resolution for the digital input port to accommodate the 8 digital input lines and 8 bits of resolution for the digital output port to accommodate the 8 digital output lines. These lines are organized as isolated, dedicated ports. You cannot configure port resolution through software.

Operation Modes

Using software, you can read from a single digital input line or the entire digital input port, or write to a single digital output line or the entire digital output port. You can also return the value of the entire digital input port in the analog input data stream if you want to correlate analog input data with digital events; refer to [page 105](#) for more information.



Troubleshooting

General Checklist	114
Technical Support	116
If Your Instrument Needs Factory Service	117

General Checklist

Should you experience problems using a TEMPpoint, VOLTpoint, or MEASURpoint instrument, do the following:

1. Read all the documentation provided for your product. Make sure that you have added any "Read This First" information to your manual and that you have used this information.
2. Check the Instrument OMNI CD for any README files and ensure that you have used the latest installation and configuration information available.
3. Check that your system meets the requirements stated in [Chapter 2](#).
4. Check that you have installed your hardware properly using the instructions in [Chapter 3](#).
5. Check that you have wired your signals properly using the instructions in [Chapter 4](#).
6. Check that you have installed Java and configured your web browser appropriately using the instructions on [page 67](#).
7. Search the DT Knowledgebase in the Support section of the Data Translation web site (at www.datatranslation.com) for an answer to your problem.

If you still experience problems, try using the information in [Table 7](#) to isolate and solve the problem. If you cannot identify the problem, refer to [page 116](#).

Table 7: Troubleshooting Problems

Symptom	Possible Cause	Possible Solution
Instrument is not found.	The instrument cannot communicate with the network.	Ensure that your instrument is properly connected; see the instructions in Chapter 3 .
		If your PC has a static IP address, reconfigure it for Auto-IP using the instructions on page 154 .
		Check your LAN configuration; see the instructions on page 78 .
		Check the IP address of the instrument by opening a Command Prompt window (Start -> Programs -> Accessories -> Command Prompt) and entering the command "ipconfig /all". The IP settings of your instrument are returned.
		Ping the instrument by opening a Command Prompt window (Start -> Programs -> Accessories -> Command Prompt) and entering the command "ping address", where <i>address</i> is the IP address of your instrument. If a timeout message is returned, the IP address is incorrect. If a "no host" error message is returned, the subnet mask is incorrect. Refer to page 42 for more information on IP and subnet addresses.
		If needed, reset the instrument using the instructions on page 44 .

Table 7: Troubleshooting Problems (cont.)

Symptom	Possible Cause	Possible Solution
Instrument does not respond.	The instrument configuration is incorrect.	Check your LAN configuration; see the instructions on page 78 .
		Check the IP address of the instrument by opening a Command Prompt window (Start -> Programs -> Accessories -> Command Prompt) and entering the command "ipconfig /all". The IP settings of your instrument are returned.
		Ping the instrument by opening a Command Prompt window (Start -> Programs -> Accessories -> Command Prompt) and entering the command "ping address", where <i>address</i> is the IP address of your instrument. If a timeout message is returned, the IP address is incorrect. If a "no host" error message is returned, the subnet mask is incorrect. Refer to page 42 for more information on IP and subnet addresses.
	If needed, reset the instrument using the instructions on page 44 .	
	The instrument is damaged.	Contact Data Translation for technical support; refer to page 116 .
Intermittent operation.	Loose connections or vibrations exist.	Check your wiring and tighten any loose connections or cushion vibration sources; see the instructions in Chapter 4 .
	The instrument is overheating.	Check environmental and ambient temperature; consult the specifications on page 132 of this manual and the documentation provided by your computer manufacturer for more information.
	Electrical noise exists.	Check your wiring and either provide better shielding or reroute unshielded wiring; see the instructions in Chapter 4 .
Data appears to be invalid.	An open connection exists.	Check your wiring and fix any open connections; see the instructions in Chapter 4 .
	A transducer is not connected to the channel being read.	Check the transducer connections; see the instructions in Chapter 4 .
	The thermocouple, RTD, or voltage input that you connected to the channel does not match the software configuration for that channel.	Check your wiring and ensure that what you specify in software matches your hardware configuration; see the instructions in Chapter 4 .
	Your instrument may need recalibration.	<p>The instrument is calibrated at the factory. Thereafter, yearly calibration is recommended. Use the Measurement Instrument Calibration Utility, described on page 21, or return your instrument to Data Translation for recalibration.</p> <p>For information on factory recalibration, contact Data Translation at 508-481-3700, ext. 1323 (if you are in the USA) or call your local distributor (if you are located outside the USA); see our web site (www.datatranslation.com) for the name and telephone number of your nearest distributor.</p>

Technical Support

If you have difficulty using your TEMPpoint, VOLTpoint, or MEASURpoint instrument, Data Translation's Technical Support Department is available to provide technical assistance.

To request technical support, go to our web site at <http://www.datatranslation.com> and click on the Support link.

When requesting technical support, be prepared to provide the following information:

- Your product serial number
- The hardware/software product you need help on
- The version of the Instrument OMNI CD you are using
- Your contract number, if applicable

If you are located outside the USA, contact your local distributor; see our web site (www.datatranslation.com) for the name and telephone number of your nearest distributor.

If Your Instrument Needs Factory Service

If your TEMPpoint, VOLTpoint, or MEASURpoint instrument must be returned to Data Translation, do the following:

1. Record the instrument's serial number, and then contact the Customer Service Department at (508) 481-3700, ext. 1323 (if you are in the USA) and obtain a Return Material Authorization (RMA).

If you are located outside the USA, call your local distributor for authorization and shipping instructions; see our web site (www.datatranslation.com) for the name and telephone number of your nearest distributor. All return shipments to Data Translation must be marked with the correct RMA number to ensure proper processing.

2. Using the original packing materials, if available, package the instrument as follows:
 - Wrap the instrument in an electrically conductive plastic material. Handle with ground protection. A static discharge can destroy components on the instrument.
 - Place in a secure shipping container.
3. Return the instrument to the following address, making sure the RMA number is visible on the outside of the box.

Customer Service Dept.
Data Translation, Inc.
100 Locke Drive
Marlboro, MA 01752-1192



Specifications

Basic Instrument Specifications	120
Thermocouple Specifications	121
RTD Specifications	125
Isolation and Protection Specifications	126
Memory Specifications	127
Temperature Stability Specifications	128
Voltage Measurement Specifications	129
Digital I/O Specifications	131
Digital I/O Specifications	131
Power, Physical, and Environmental Specifications	132
Regulatory Specifications	133
Connector Specifications	134

Note: All analog input specifications are based on the Moving Average filter type; see [page 81](#) for more information on filter types.

Basic Instrument Specifications

Table 8 lists the basic instrument specifications for TEMPpoint, VOLTpoint, and MEASURpoint instruments.

Table 8: Basic Instrument Specifications

Feature	Specifications
Number of channels in channel list	Up to 48 analog input channels and one digital input port
A/D converter type	24-bit Sigma-Delta

Thermocouple Specifications

Table 9 lists the thermocouple specifications for thermocouple channels on the TEMPpoint and MEASURpoint instruments.

Table 9: Thermocouple Specifications

Feature	Specifications
Thermocouple types (software-selectable)	B, E, J, K, N, R, S, T
A/D resolution	24-bits
Sample rate	10 Samples/s
Thermal disturbance channel-to-channel	None
Upscale break detection current DT8871U and DT8874: DT8871:	+10 nA +100 nA
System temperature error DT8871U and DT8874: DT8871:	See Table 10 on page 121 See Table 11 on page 123

System Temperature Error for the DT8871U and DT8874

Table 10 lists the accuracy of the DT8871U and DT8874 for each thermocouple type at several temperature points over the dynamic range of the instrument.

Table 10: Calculated Thermocouple Accuracy of the DT8871U and DT8874

Input Temp.	Thermocouple Type ^a							
	J	K	T	E	S	R	B	N
-100° C	±0.17° C	±0.17° C	±0.16° C	±0.16° C	-----	-----	-----	±0.16° C
0° C	±0.15° C	±0.16° C	±0.16° C	±0.15° C	±0.2° C	±0.2° C	-----	±0.16° C
100° C	±0.18° C	±0.15° C	±0.16° C	±0.15° C	±0.18° C	±0.18° C	-----	±0.15° C
300° C	±0.15° C	±0.17° C	±0.16° C	±0.15° C	±0.18° C	±0.18° C	±0.23° C	±0.15° C
500° C	±0.15° C	±0.15° C	-----	±0.15° C	±0.18° C	±0.17° C	±0.21° C	±0.15° C
700° C	±0.15° C	±0.15° C	-----	±0.16° C	±0.18° C	±0.18° C	±0.17° C	±0.16° C
900° C	±0.15° C	±0.17° C	-----	±0.17° C	±0.18° C	±0.18° C	±0.19° C	±0.16° C
1100° C	±0.15° C	±0.16° C	-----	-----	±0.19° C	±0.18° C	±0.18° C	±0.16° C
1400° C	-----	-----	-----	-----	±0.18° C	±0.18° C	±0.17° C	-----

a. Conditions for accuracy measurements:

Warm-up time of 45 minutes. Inclusive of typical 0.15° C CJC error (maximum CJC error is 0.25° C).

Inclusive of typical 0.25 µV offset error (maximum offset error is 2.5 µV). Exclusive of thermocouple errors.

Exclusive of noise (see [Figure 34](#) and [Figure 35](#) for more information about system noise).

The histograms shown in [Figure 34](#) and [Figure 35](#) characterize the Gaussian system noise distribution for each of the available filter types on the DT8871U and DT8874. Note that converting μV error to temperature error depends on thermocouple type. For example, a K thermocouple changes approximately $39 \mu\text{V}$ per degrees C; therefore, a noise level of $0.1 \mu\text{V}$ adds less than 0.003°C error ($0.1 \mu\text{V} / 39 \mu\text{V}$) for a type K thermocouple.

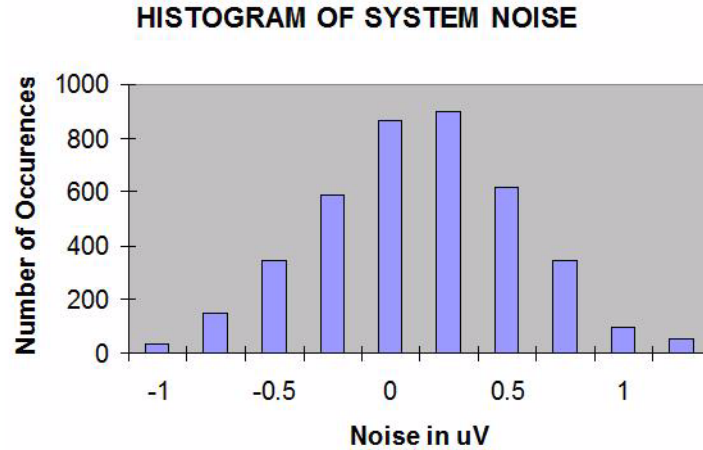

Figure 34: System Noise on the DT8871U and DT8874 Using No Software Filter (Raw Filter)

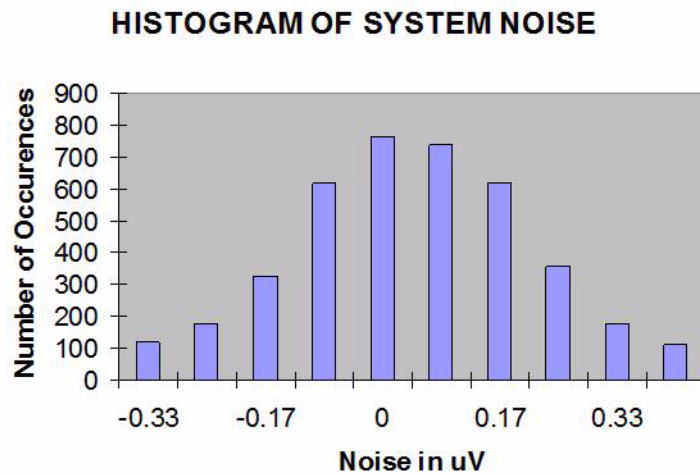

Figure 35: System Noise on the DT8871U and DT8874 Using the Moving Average Filter

System Temperature Error for the DT8871

Table 11 lists the accuracy of the DT8871 for each thermocouple type at several temperature points over the dynamic range of the instrument.

Table 11: Calculated Thermocouple Accuracy of the DT8871

Input Temperature	Thermocouple Type ^a							
	J	K	T	E	S	R	B	N
-100° C	±0.33° C	±0.37° C	±0.38° C	±0.31° C	-----	-----	-----	±0.44° C
0° C	±0.3° C	±0.33° C	±0.33° C	±0.28° C	±1.12° C	±1.14° C	-----	±0.39° C
100° C	±0.31° C	±0.29° C	±0.31° C	±0.27° C	±0.88° C	±0.86° C	-----	±0.35° C
300° C	±0.29° C	±0.34° C	±0.29° C	±0.26° C	±0.75° C	±0.71° C	±1.84° C	±0.33° C
500° C	±0.28° C	±0.31° C	-----	±0.26° C	±0.71° C	±0.66° C	±1.2° C	±0.33° C
700° C	±0.27° C	±0.3° C	-----	±0.27° C	±0.68° C	±0.63° C	±0.92° C	±0.33° C
900° C	±0.27° C	±0.34° C	-----	±0.28° C	±0.66° C	±0.6° C	±0.8° C	±0.33° C
1100° C	±0.28° C	±0.34° C	-----	-----	±0.64° C	±0.58° C	±0.71° C	±0.34° C
1400° C	-----	-----	-----	-----	±0.62° C	±0.56° C	±0.64° C	-----

a. **Conditions for accuracy measurements:**

Warm-up time of 45 minutes. Inclusive of typical 0.2° C CJC error (maximum CJC error is 0.3° C).

Inclusive of typical 5 μ V offset error (maximum offset error is 50 μ V). Exclusive of thermocouple errors.

Exclusive of noise (see Figure 36 and Figure 37 for more information about system noise).

The histograms shown in Figure 36 and Figure 37 characterize the Gaussian system noise distribution for each of the available filter types on the DT8871. Note that converting μ V error to temperature error depends on thermocouple type. For example, a K thermocouple changes approximately 39 μ V per degrees C; therefore, a noise level of 10 μ V adds 0.3° C error (10 μ V / 39 μ V) for a type K thermocouple.

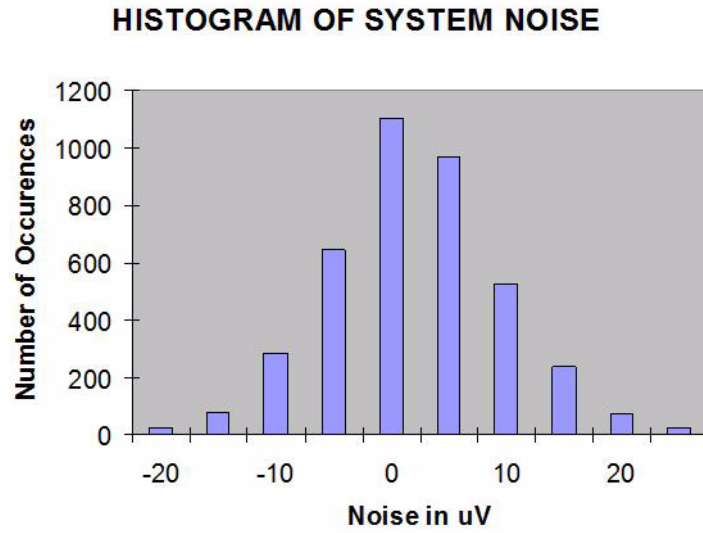

Figure 36: System Noise on the DT8871 Using No Software Filter (Raw Filter)

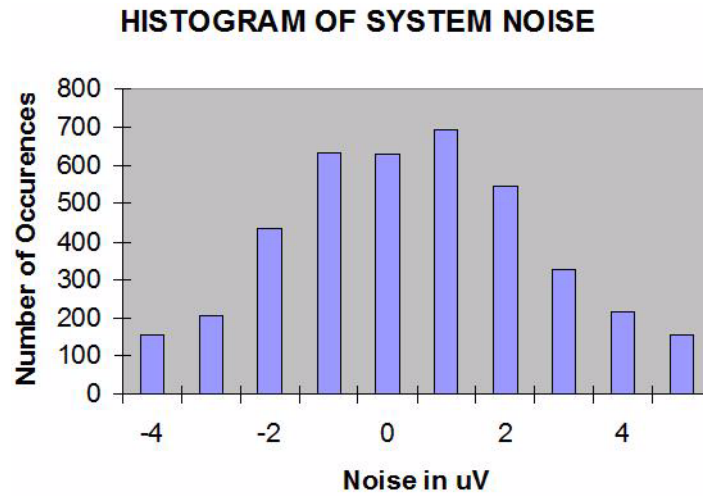

Figure 37: System Noise on the DT8871 Using the Moving Average Filter

RTD Specifications

[Table 12](#) lists the specifications for RTD channels on the TEMPpoint and MEASURpoint instruments.

Table 12: RTD Specifications

Feature	Specifications
RTD types (software-selectable)	Platinum 100 Ω , 500 Ω , and 1000 Ω
A/D converter resolution	24-bits
Sample rate	10 Samples/s
Supported temperature range	-200 to +850° C (European standard)
Current source Absolute current:	425 μ A, \pm 0.5% at 25° C (calibrated in firmware)
Drift:	10 ppm/° C maximum
Drift per year:	\pm 100 ppm typical
Internal reference	+1.250 \pm 0.002 V
Thermal disturbance channel-to-channel	None
Supported RTD alpha curves	See Table 13 on page 125

[Table 13](#) lists the RTD alpha curves that are supported by RTD channels.

Table 13: Supported RTD Alpha Curves

Alpha (Average Temperature Coefficient of Resistance (/° C))	Nominal Resistance at 0° C	Organization	Standard
0.00385	100 Ω	British Standard	BS1904: 1984
		Deutschen Institut für Normung	DIN 43760: 1980
0.00392	98.129 Ω	Scientific Apparatus Manufacturers of America	SAMA RC-4-1966

Isolation and Protection Specifications

Table 14 lists the isolation and protection specifications for the analog input subsystem on the TEMPpoint, VOLTpoint, and MEASURpoint instruments.

Table 14: Isolation and Protection Specifications

Feature	Specifications
Overvoltage protection (power on/off) DT8871U, DT8871, and DT8874 thermocouple channels: DT8872 and DT8874 RTD channels: DT8873 and DT8874 high voltage channels:	± 40 V ± 40 V ± 500 V
ESD protection Arc: Contact:	8 kV 4 kV
Isolation voltage to the host computer	± 500 V
Channel-to-channel isolation	± 500 V

Memory Specifications

Table 15 lists the memory specifications for the analog input subsystem on TEMPpoint, VOLTpoint, and MEASURpoint instruments.

Table 15: Memory Specifications

Feature	Specifications
Data memory onboard	4 MByte
For Data logger built in, maximum time before old data is overwritten ^a	
48 channels @ 10 Hz:	30 minutes
48 channels @ 1 Hz:	5 hours
48 channels @ 0.1 Hz:	50 hours

- a. Assumes limit detection is off for all channels, and for thermocouple channels, assumes CJC data is not collected. If power fails, all temperature data in the system is lost. The channel input type and filter settings are still available after power on, but the channel and digital I/O labels and channel limits are lost.

Temperature Stability Specifications

Table 16 lists the temperature stability specifications for thermocouple channels on the TEMPpoint and MEASURpoint instruments.

Table 16: Temperature Stability Specifications for Thermocouple Channels

Feature	Specifications
Additional error due to ambient temperature change ^a J-type thermocouple: K-type thermocouple: B-type thermocouple: E-type thermocouple: N-type thermocouple: R-type thermocouple: S-type thermocouple: T-type thermocouple:	0.010° C per degree ambient change, typical 0.011° C per degree ambient change, typical 0.014° C per degree ambient change, typical 0.010° C per degree ambient change, typical 0.011° C per degree ambient change, typical 0.012° C per degree ambient change, typical 0.012° C per degree ambient change, typical 0.010° C per degree ambient change, typical
Warm-up time	45 minutes
CJC Error: Accuracy: Drift per year:	±0.2° C Corrected in ROM @ 25° C to zero error ±50 ppm typical

a. Includes the A/D reference, gain, and CJC errors.

Table 17 lists the temperature stability specifications for RTD channels on the TEMPpoint and MEASURpoint instruments.

Table 17: Temperature Stability Specifications for RTD Channels

Feature	Specifications
System temperature error ^a Pt100: Pt500: Pt1000:	±0.07° C, ±0.005% of reading ±0.01° C, ±0.005% of reading ±0.007° C, ±0.005% of reading
Temperature resolution	±0.0003° C (based on a European PT1000 RTD)
Warm-up time	1 minute

a. The system temperature error is based on the auto zero and system noise error (±0.07° C for a Pt100 RTD, ±0.01° C for a Pt500 RTD, or ±0.007° C for a Pt1000 RTD) plus the gain error of the A/D and output impedance of the current source over the voltage range (±0.005% of the reading). For example, the maximum error of a Pt100 RTD at 100° C is ±0.075° C (±0.07° C plus a gain error of ±0.005° C).

Voltage Measurement Specifications

Table 18 lists the voltage measurement specifications for the TEMPpoint, VOLTpoint, and MEASURpoint instruments.

Table 18: Voltage Measurement Specifications

Feature	Specifications
Input voltage range (no compensation) DT8871U and DT8874 thermocouple channels: DT8871: DT8872 and DT8874 RTD channels: DT8873 and DT8874 high voltage channels:	± 0.0750 V ± 1.2500 V ± 1.2500 V ± 10 V, ± 100 V, or ± 400 V ^a
A/D converter resolution	24-bits
Voltage resolution DT8871U and DT8874 thermocouple channels: DT8871: DT8872 and DT8874 RTD channels: DT8873 and DT8874 high voltage channels:	0.015 μ V 0.3 μ V 0.3 μ V 1.2 μ V for the ± 10 V input range; 12 μ V for the ± 100 V input range; 48 μ V for the ± 400 V input range
Sample rate	10 Samples/s
Gain	1
Input impedance DT8871U and DT8874 thermocouple channels: DT8871: DT8872 and DT8874 RTD channels: DT8873 and DT8874 high voltage channels:	5 M Ω typical 5 M Ω typical > 100 M Ω > 1 M Ω (Power ON or OFF)
Input common mode voltage	± 500 V
Common mode rejection @ 60 Hz and 50 Hz	> 150 dB
Coupling	DC
System linearity DT8871U and DT8874 thermocouple channels: DT8871: DT8872 and DT8874 RTD channels: DT8873 and DT8874 high voltage channels:	$\pm 0.005\%$ $\pm 0.005\%$ $\pm 0.001\%$ $\pm 0.001\%$
System gain error (includes all noise sources; gain = 1) DT8871U and DT8874 thermocouple channels: DT8871: DT8872 and DT8874 RTD channels: DT8873 and DT8874 high voltage channels:	$\pm 0.00075\%$ of full-scale range $\pm 0.00075\%$ of full-scale range $\pm 0.00075\%$ of full-scale range $\pm 0.01\%$ of reading
System zero error (includes all noise sources; gain = 1; no filter) DT8871U and DT8874 thermocouple channels: DT8871: DT8872 and DT8874 RTD channels: DT8873 and DT8874 high voltage channels:	0.25 μ V RMS 5 μ V RMS ± 12 μ V ± 300 μ V for the ± 10 V input range; ± 2 mV for the ± 100 V input range; ± 8 mV for the ± 400 V input range

Table 18: Voltage Measurement Specifications (cont.)

Feature	Specifications
System drift error, zero DT8871U and DT8874 thermocouple channels: DT8871: DT8872 and DT8874 RTD channels: DT8873 and DT8874 high voltage channels:	$\pm 0.02 \mu\text{V}/^\circ\text{C}$ typical $\pm 0.02 \mu\text{V}/^\circ\text{C}$ typical $\pm 0.10 \mu\text{V}/^\circ\text{C}$ $\pm 0.5 \mu\text{V}/^\circ\text{C}$ for the $\pm 10\text{ V}$ input range; $\pm 5 \mu\text{V}/^\circ\text{C}$ for the $\pm 100\text{ V}$ input range; $\pm 20 \mu\text{V}/^\circ\text{C}$ for the $\pm 400\text{ V}$ input range
System drift error, gain DT8871U and DT8874 thermocouple channels: DT8871: DT8872 and DT8874 RTD channels: DT8873 and DT8874 high voltage channels:	$\pm 4 \text{ ppm}/^\circ\text{C}$ $\pm 4 \text{ ppm}/^\circ\text{C}$ $\pm 10 \text{ ppm}/^\circ\text{C}$ $\pm 15 \text{ ppm}/^\circ\text{C}$
A/D reference Drift: Drift per year:	$\pm 8 \text{ ppm}/^\circ\text{C}$ maximum $\pm 100 \text{ ppm}$ typical
Full-scale long-term stability DT8871U and DT8874 thermocouple channels: DT8871: DT8872 and DT8874 RTD channels: DT8873 and DT8874 high voltage channels:	$\pm 100 \text{ ppm/year}$ typical $\pm 100 \text{ ppm/year}$ typical $\pm 0.05^\circ\text{C}$ per year @ 0°C ($\pm 0.27^\circ\text{C}$ per year @ full-scale temperature) $\pm 100 \text{ ppm/year}$ typical
Warm-up time for the DT8873 and DT8874 high voltage channels:	1 hour

a. You configure the input range for each channel using software.

Digital I/O Specifications

Table 19 lists the specifications for the digital input (DIN) and digital output (DOUT) subsystems on the TEMPpoint, VOLTpoint, and MEASURpoint instruments.

Table 19: Digital I/O Specifications

Feature	Specifications
Number of digital I/O lines	16 (8 In, 8 Out)
Number of ports	2, 8-bit (1 In, 1 Out)
Inputs Input type: High input voltage: Low input voltage: High input current: Low input current: Termination	DC +3 to +28 V < +1.5 V 2.2 k Ω resistor to 1.2 V 2.2 k Ω resistor to 1.2 V Series 2.2 k Ω
Outputs Output type: Output driver: High output: Low output: Breakdown voltage: Contact impedance:	Solid-state relay CMOS ± 30 V 0.4 V @ 400 mA ± 60 V 1 Ω
Isolation voltage To computer ground: Channel to channel	± 500 V ± 250 V ^a

- a. Determined by the pin spacing in the 37-pin digital connector. For greater channel-to-channel isolation, use every other digital I/O line; using every other digital I/O line allows ± 500 V isolation channel-to-channel.

Power, Physical, and Environmental Specifications

Table 20 lists the power, physical, and environmental specifications for the TEMPpoint, VOLTpoint, and MEASURpoint instruments.

Table 20: Power, Physical, and Environmental Specifications

Feature	Specifications
External power requirements	+5 V \pm 0.25V @ 2 A (0.9 mA typical)
Physical Dimensions of enclosure:	88.14 (H) x 212.85 mm (W) x 211.43 mm (D)
Weight:	1704 g
Environmental Operating temperature range:	0° C to 55° C
Storage temperature range:	-25° C to 85° C
Relative humidity:	to 95%, noncondensing
Altitude:	up to 10,000 feet

Regulatory Specifications

Table 21 lists the regulatory specifications for the TEMPpoint, VOLTpoint, and MEASURpoint instruments.

Table 21: Regulatory Specifications

Feature	Specifications
Emissions (EMI)	FCC Part 15, EN55022:1994 + A1:1995 + A2:1997 VCCI, AS/NZS 3548 Class A
Immunity	EN61000-6-1:2001
RoHS (EU Directive 2002/95/EG)	Compliant (as of July 1st, 2006)
Aerospace Material Specification	Compliant with AMS2750D

Connector Specifications

This section lists the specifications for the following connector types:

- Thermocouple connectors
- RTD connectors
- High voltage connectors
- Ethernet connector

Thermocouple Connectors

Table 22 lists the specifications for the thermocouple connectors used on the TEMPpoint and MEASURpoint instruments.

Table 22: Thermocouple Connector Specifications

Feature	Specifications
Thermocouple jacks	Cu-Cu Omega plugs (White SMPW-U-M)
Thermocouple connector	Omega part# PCC-SMP-U-100-R-CE-ROHS

RTD Connectors

Table 23 lists the specifications for the RTD connectors used on the TEMPpoint and MEASURpoint instruments.

Table 23: RTD Connector Specifications

Feature	Specifications
4-Position screw terminal block header	Phoenix Contact 1803293
4-Position screw terminal block plug	Phoenix Contact 1803594

High Voltage Connectors

Table 24 lists the specifications for the high voltage connectors used on the VOLTpoint and MEASURpoint instruments.

Table 24: Voltage Connector Specifications

Feature	Specifications
4-Position screw terminal block header	Phoenix Contact 1803293
4-Position screw terminal block plug	Phoenix Contact 1803594

Ethernet (RJ45) Connector

The Ethernet (RJ45) connector used on the TEMPpoint, VOLTpoint, and MEASURpoint instruments is shown in [Figure 38](#).

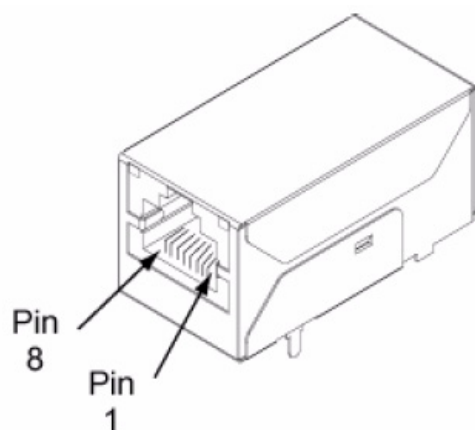

Figure 38: Ethernet (RJ45) Connector

The pin assignments of this connector are described in [Table 25](#):

Table 25: Ethernet Connector Pin Assignments

Pin	Signal Name	Description
1	TXD+	Transmit Data+
2	TXD-	Transmit Data-
3	RXD+	Receive Data+
4	EPWR+	Power from Switch+
5	EPWR+	Power from Switch+
6	RXD-	Receive Data-
7	EPWR-	Power from Switch-
8	EPWR-	Power from Switch-

Note: TEMPpoint, VOLTpoint, and MEASURpoint instruments do not support Auto-MDIX.



Connector Pin Assignments

Table 26 lists the pin assignments for the 37-pin digital I/O connector on TEMPpoint, VOLTpoint, and MEASURpoint instruments.

Table 26: Digital I/O Connector Pin Assignments

Pin	Description	Pin	Description
1	Digital Input 0+	–	
2	Digital Input 1+	20	Digital Input 0–
3	Digital Input 2+	21	Digital Input 1–
4	Digital Input 3+	22	Digital Input 2–
5	Digital Input 4+	23	Digital Input 3–
6	Digital Input 5+	24	Digital Input 4–
7	Digital Input 6+	25	Digital Input 5–
8	Digital Input 7+	26	Digital Input 6–
9	Not Connected	27	Digital Input 7–
10	Digital Output 0	28	Not Connected
11	Digital Output 1	29	Digital Output 0
12	Digital Output 2	30	Digital Output 1
13	Digital Output 3	31	Digital Output 2
14	Digital Output 4	32	Digital Output 3
15	Digital Output 5	33	Digital Output 4
16	Digital Output 6	34	Digital Output 5
17	Digital Output 7	35	Digital Output 6
18	Not Connected	36	Digital Output 7
19	Not Connected	37	Not Connected



Using the Measurement Application

Overview	140
Running the Measurement Application	141
Changing the Configuration of Your Instrument	144
Defining Alarm Limits	146
Logging Data to Disk	148
Viewing a Data File	150
Reading Digital Input Values	151
Exiting from the Measurement Application	152

Overview

In addition to the web interface, described in [Chapter 5](#), you can verify the operation of your TEMPpoint, VOLTpoint, or MEASURpoint instrument using the Measurement Application that is provided with the instrument. The Measurement Application, developed using Measure Foundry, lets you perform the following functions:

- Configure your instrument
- Acquire temperature, resistance, and/or voltage data from up to 48 analog input channels
- Display temperature, resistance, and/or voltage data during acquisition
- Use a Chart Recorder to display and log data to an.hpf file for later analysis
- View any .hpf file, and view the last recorded .hpf data file in Microsoft Excel®
- Set minimum and maximum alarm limits for each channel
- Set the state of the digital output lines based on alarm limits
- Read the state of the digital input port

If desired, you can use Measure Foundry to customize this application.

Refer to [page 31](#) for information on installing the Measurement Application.

Running the Measurement Application

To run the Measurement Application, perform the following steps:

1. Click **Start -> Programs -> Data Translation, Inc -> Measurement -> Measurement Application**

The Device Selection screen is displayed:

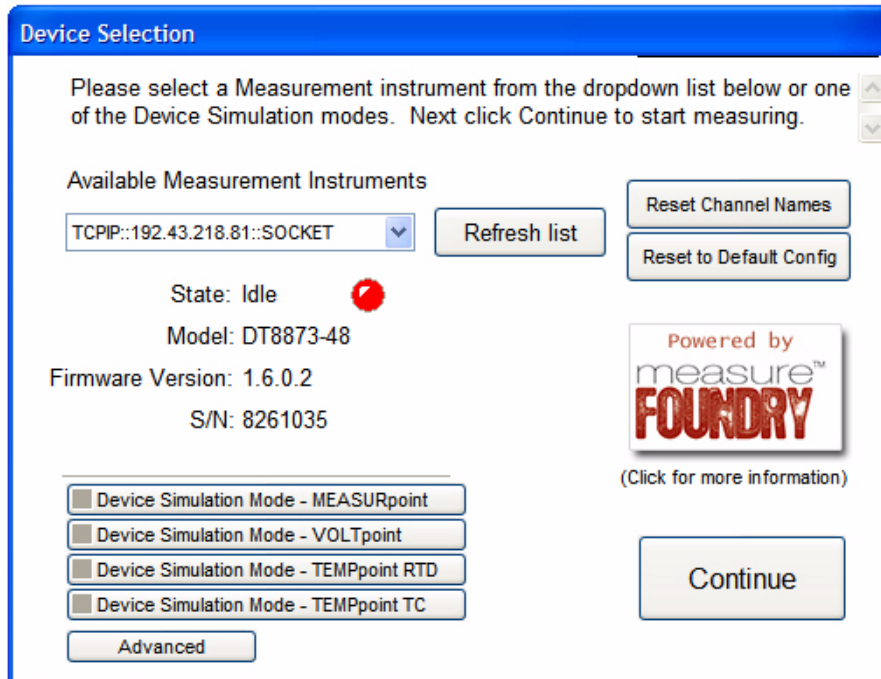

2. By default, the application "discovers" all TEMPpoint, VOLTpoint, and MEASURpoint instruments that are available and displays them in the list of Available Instruments. If you want to refresh this list to determine if other TEMPpoint, VOLTpoint, or MEASURpoint instruments are available, click **Refresh list**.
3. If your instrument is included in the list of Available Instruments and you want to connect to it, select the connect string for the instrument that you want to use from the list of Available Instruments, and then go to step 6.
Information about the instrument, including the scanning status, model number, firmware version, and serial number, is displayed.
4. If you do not have a TEMPpoint, VOLTpoint, or MEASURpoint instrument connected or if you want to simulate the operation of an instrument, click one of the following selections, and then go to step 6:
 - **Device Simulation Mode - MEASURpoint** – Simulates the operation of a MEASURpoint instrument.
 - **Device Simulation Mode - VOLTpoint** – Simulates the operation of a VOLTpoint instrument.
 - **Device Simulation Mode - TEMPpoint RTD** – Simulates the operation of a DT9872 or DT8872 TEMPpoint instrument.

- **Device Simulation Mode - TEMPpoint TC** – Simulates the operation of a DT9871, DT9871U, DT8871, or DT8871U TEMPpoint instrument.
When selected, the button indicator turns green.
5. If your instrument is not included in the list of Available instruments, but you want to manually connect to it, do the following:
 - a. Click **Advanced**.
The following screen is displayed:

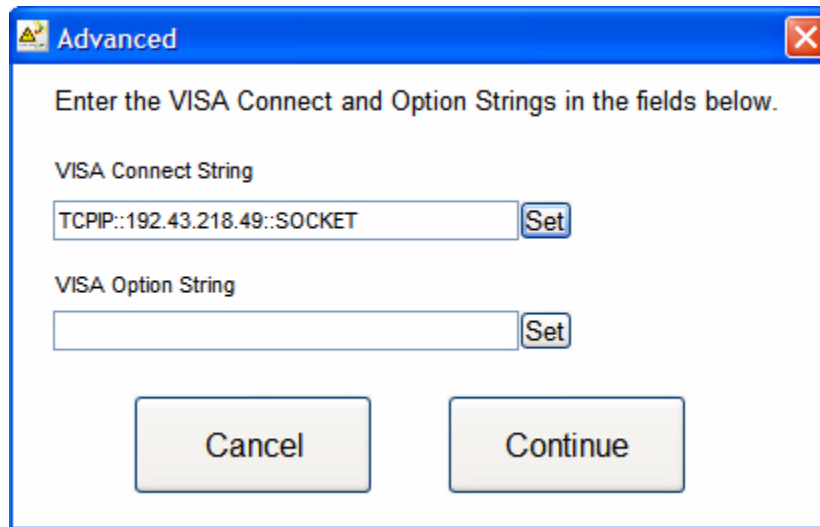

- b. Determine the IP address of your instrument on the TCP/IP network using an LXI discovery tool, such as the Eureka Discovery Utility provided with your instrument, see [page 72](#) for information on using this utility.
 - c. Enter the VISA Connect String for your instrument (such as TCPIP::192.43.218.69::INSTR or TCPIP::192.43.218.44::SOCKET), and click **Set**.
 - d. If you want to simulate the operation of an instrument, enter the string **simulate=true,model=xxxxxx** in the VISA Option String text box and click **Set**, where *xxxxxx* is the model number of the instrument you want to simulate (DT9871, DT8871, DT9872, and DT8872 for TEMPpoint instruments, DT9873 and DT8873 for VOLTpoint instruments, and DT987x and DT887x for MEASURpoint instruments).
6. (Optional) If you previously used the Measurement Application, and you want to overwrite the configuration of the last session (which was automatically saved) with the default configuration for the selected instrument, click the **Reset to Default Config** button.
7. (Optional) If you previously used the Measurement Application, and you want to overwrite the names of the channels (which were automatically saved) with the default channel names for the selected instrument, click the **Reset Channel Names** button. Note that this step is useful especially when changing between instrument types.
8. Click **Continue**.
The latest state is saved and used when the application is next run, and the Channel Overview screen of the Measurement Application is displayed. Note that data acquisition is started automatically and temperature values are displayed (in degrees C), by default.

Channel Type	Ch40	Ch41	Ch42	Ch43	Ch44	Ch45	Ch46	Ch47
Volts	7.70 V	8.10 V	8.30 V	7.90 V	8.00 V	7.60 V	7.60 V	8.10 V
Volts	Ch32: 7.50 V	Ch33: 7.60 V	Ch34: 8.40 V	Ch35: 7.50 V	Ch36: 7.60 V	Ch37: 8.40 V	Ch38: 7.90 V	Ch39: 8.10 V
RTD	Ch24: 48.00 C	Ch25: 50.03 C	Ch26: 52.02 C	Ch27: 54.02 C	Ch28: 56.02 C	Ch29: 58.01 C	Ch30: 60.03 C	Ch31: 62.02 C
RTD	Ch16: 32.03 C	Ch17: 34.00 C	Ch18: 36.01 C	Ch19: 38.01 C	Ch20: 40.02 C	Ch21: 42.02 C	Ch22: 44.03 C	Ch23: 46.00 C
TC	Ch8: 16.01 C	Ch9: 18.02 C	Ch10: 20.02 C	Ch11: 22.03 C	Ch12: 24.03 C	Ch13: 26.03 C	Ch14: 28.00 C	Ch15: 30.02 C
TC	Ch0: 0.02 C	Ch1: 2.02 C	Ch2: 4.01 C	Ch3: 6.01 C	Ch4: 8.00 C	Ch5: 10.03 C	Ch6: 12.03 C	Ch7: 14.01 C

Figure 39: Channel Overview Screen of the Measurement Application

Note that the **Channel Type** field on the left of the screen indicates the type of sensor that is used for the corresponding row of measurement values. For example,

- *TC* represents the values for thermocouple channels
- *RTD* represents the values for RTD channels
- *Volts* represents the values for voltage input channels with an input range of ± 10 V

Changing the Configuration of Your Instrument

To change the configuration of your instrument, follow these steps:

1. Stop acquisition by clicking the **Start/Stop** button from the main window or by clicking **Stop Acquisition** from the **Acquisition** menu.
2. Click the **Configuration** menu, and then click **Change Configuration**.
The Change Configuration screen is displayed:

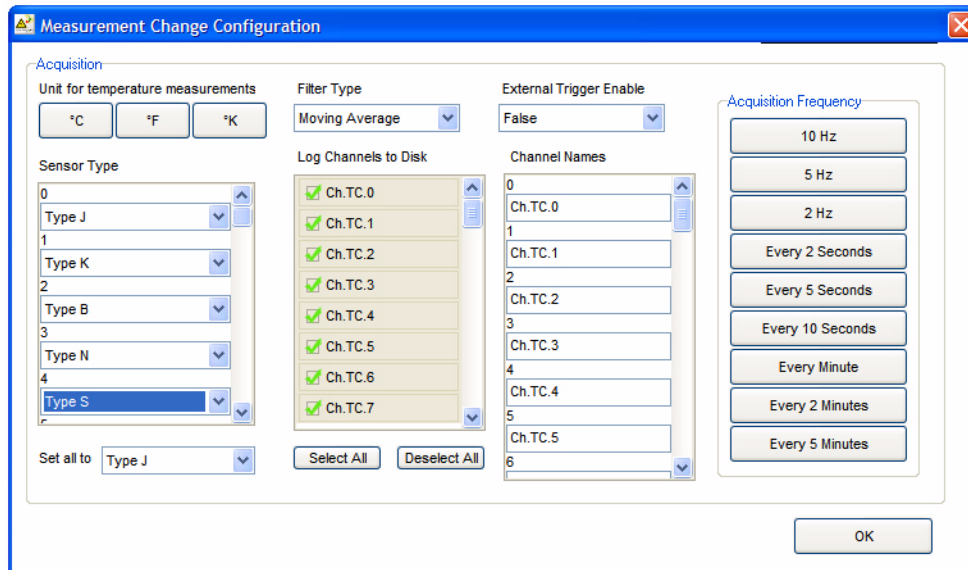

3. Under **Unit**, select the temperature units in which to display temperature data: °C (Celsius), °F (Fahrenheit), or °K (Kelvin).
4. Under **Sensor Type**, select the input type for each of the channels.

For channels that support programmable voltage ranges, the following drop-down box is displayed; select the voltage range that you want to use for the channel:

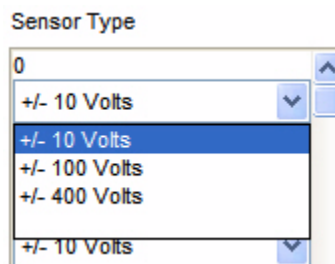

Note: If you want to set all the channels to the same configuration at once, select the configuration to apply using the **Set all to** combo box.

If you select a voltage sensor type for a channel, the data is displayed in voltage. The sensor type setting is ignored for the digital input port.

5. Under **Filter Type**, select *Moving Average* if you want to filter the data or *Raw* if you do not want to filter the data.
6. Under **Log Channels to Disk**, check the channels that you want to log to disk when you use the Chart Recorder (described on [page 148](#)). The first time you use the Measurement Application, all channels are selected for data logging.
7. Under **External Trigger Enable**, select *True* if you want to start acquisition using an external trigger signal connected to digital input line 0; otherwise, select *False*.
8. Under **Channel Names**, specify a meaningful name to represent each channel.
9. Under **Acquisition Frequency**, click the frequency (10 Hz, 5 Hz, 2 Hz, Every 2 s, Every 5 s, Every 10 s, Every Minute, Every 2 Minutes, Every 5 Minutes) at which to simultaneously sample all channels.
10. When you are finished configuring the Measurement Application, click **OK**.
11. To save the configuration settings, click the **Configuration** menu, and then click **Save Configuration File**.
12. Enter a name for the configuration file, select the directory in which to save the file, and then click **Save**.
This file has the extension (.Measurement).*

Note: You can save numerous configuration settings, if desired. To load a previously saved configuration, click the **Configuration** menu, and then click **Load Configuration File**.

13. Restart acquisition by clicking **Start Acquisition** from the **Acquisition** menu or by clicking **Start/Stop** from the main window.

Defining Alarm Limits

When you start the Measurement Application for the first time, the following alarm limits are defined for each channel:

- Minimum alarm limit = 0
- Maximum alarm limit = 100

If the acquired value for a channel is between the defined minimum and maximum alarm limits, the value is within range and is displayed in black. If the acquired value for a channel is below the minimum or above the maximum alarm limit, the value is out of range and is displayed in red.

To change the alarm limits, do the following:

1. From the **Windows** menu, select **Limit Definition**.

A screen similar to the following is displayed:

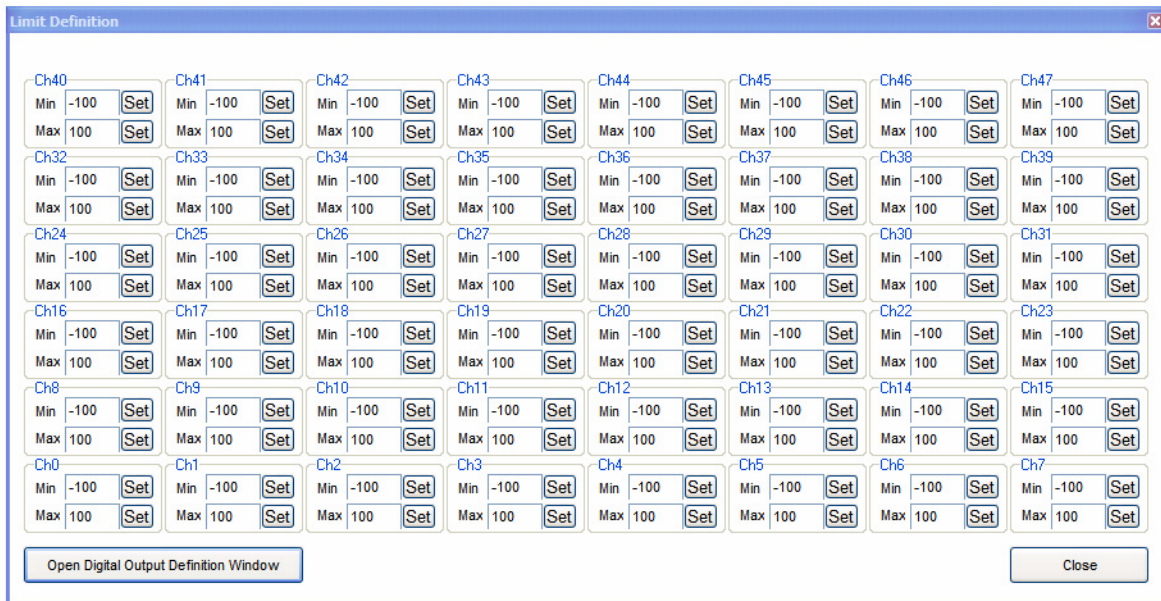

2. If you want to change the minimum alarm limit for a channel, enter a value in the **Min** field for that channel, and then click **Set** next to the value that you entered.
3. If you want to change the maximum alarm limit for a channel, enter a value in the **Max** field for that channel, and then click **Set** next to the value that you entered.
4. If you want to set a digital output line when the alarm limits for a channel are exceeded, click the **Open Digital Output Definition Window** button from the **Limit Definition** screen.

The following screen appears:

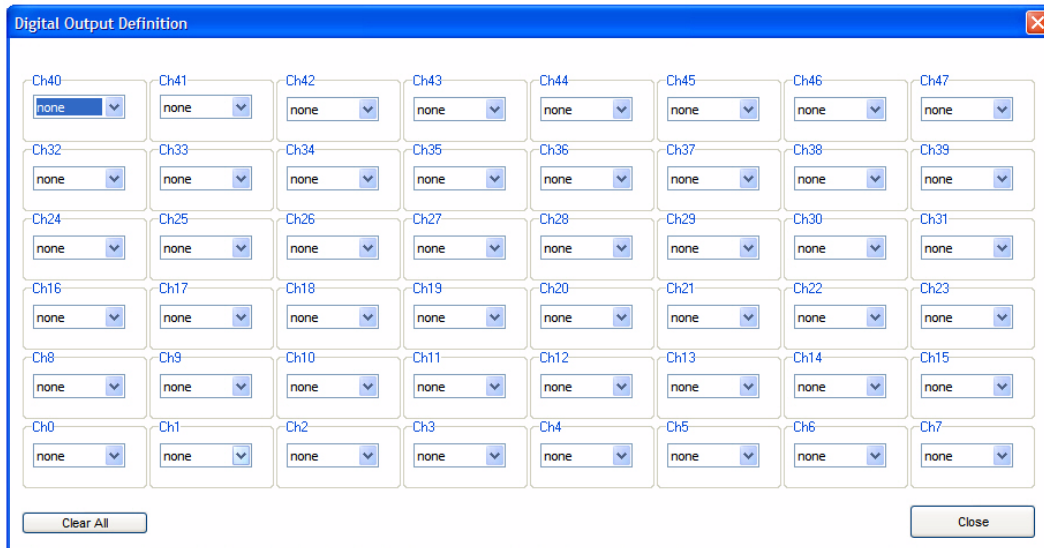

- For each channel, select the digital output line (bit) that you want to turn on when the limits for a channel are exceeded. If you do not want to set a digital output line when the alarm limits are exceeded, choose **none**.

Note: You can assign the same digital output line to multiple channels. The digital output line is turned on (1) when any of the alarm limits are exceeded on the channels that were assigned to that digital output line.

If alarm limits are not exceeded, the digital output line is turned off (0).

- To see the state of the digital output lines, click the **OUT** button from main window, or from the **Windows** menu, select **Digital Output Panel**.

A screen similar to the following appears:

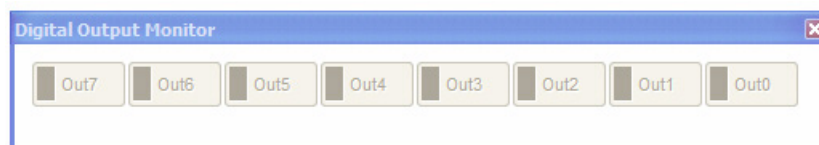

Logging Data to Disk

To log data to disk, perform the following steps:

1. Ensure that you configured the channels that you want to log to disk (see [page 145](#)).
2. Start acquisition by clicking the **Start/Stop** button from the main window or, from the **Acquisition** menu, by selecting **Start Acquisition**.
3. Click the **Chart Recorder** button on the main window, or from the **Windows** menu, select **Chart Recorder**.

A screen similar to the following appears:

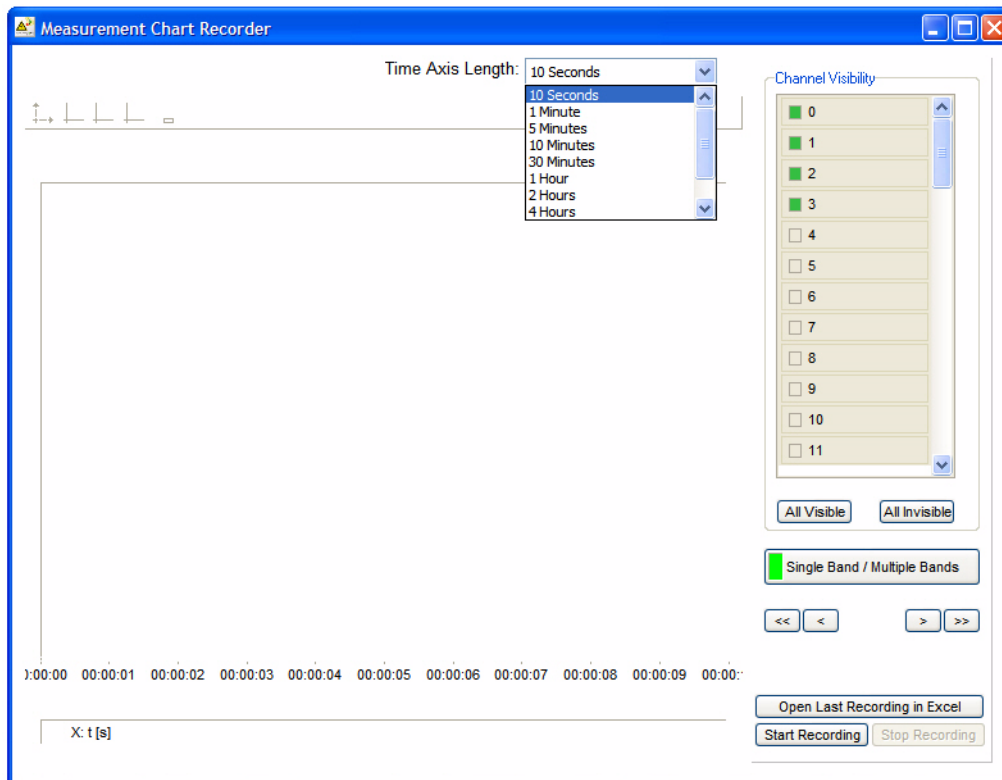

4. Under **Channel Visibility**, select the channels that you want to be visible on the display.

Note: The first time that you run the Measurement Application, all the channels are visible.

5. From the **Time Axis Length** drop-down list, select the time (10 Seconds, 1 Minute, 5 Minutes, 10 Minutes, 30 Minutes, 1 Hour, 2 Hours, 4 Hours) to use for the time axis.
6. If you want to display all the data on a single band, leave the **Single Band/Multiple Band** button untouched (the button indicator is green).

If you want to display the data for each channel on a separate band, click the **Single Band/Multiple Band** button so that the button indicator turns gray.

7. To begin recording data, click the **Start Recording** button.
You are prompted to name the file in which to store the recorded data. The data file has an .hpf extension.
8. Enter a name for the data file, and then click **Save**.
The data for each channel is then displayed on the screen and logged to disk:

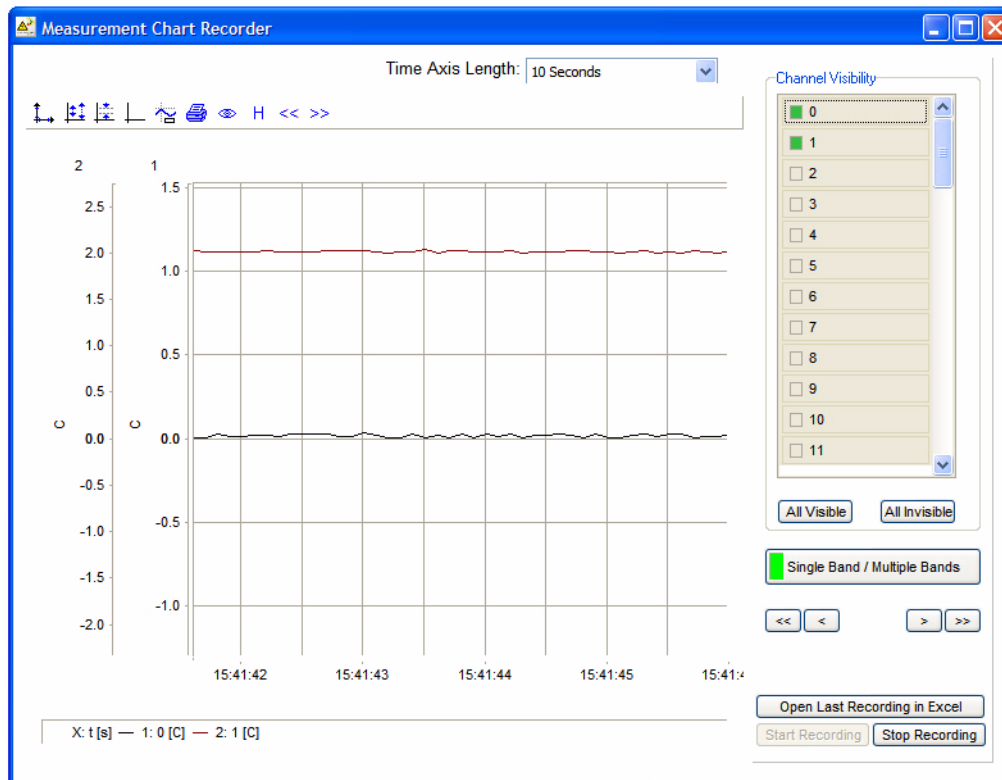

9. When you have finished recording, click the **Stop Recording** button.
10. If you want to view this data in Microsoft Excel, click the button called **Open Last Recording in Excel**.

Note: The Chart Recorder has other features, such as scrolling, autoscaling, printing, and so on. Refer to the online help provided with the Measurement Application for more information on these features.

Viewing a Data File

To view the data that you recorded in an .hpf file with the Chart Recorder, perform the following steps:

1. Click the **Load Data File** button from the main window, or from the **File** menu, select **Load Data File**.
You are prompted to select the name of the data file to view.
2. Select the name of the data file to view, and then click **Open**.
The data file is displayed in the File Viewer window.
3. You can then scroll through the data, change the scale of the display, print the data, and so on. Refer to the online help provided with the Measurement Application for more information about these features.
4. When you are finished viewing the data file, click **Close**.

Reading Digital Input Values

To read the state of the digital input port, perform the following steps:

1. Click the **Digital In** button from the main window, or from the **Windows** menu, select **Digital Input Panel**,

A screen similar to the following appears:

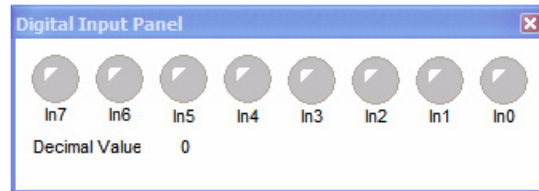

Note: The LED indicator turns green when a value of 1 is detected on the digital input line and turns gray when a value of 0 is detected on the digital input line.

Exiting from the Measurement Application

When you finished using the Measurement Application, exit from the application by selecting the **File** menu and clicking **Quit**.



Configuring Network Settings on Your PC

Configuring the PC to Use Auto-IP	154
Specifying a Static IP Address for your Instrument	157
Reconfiguring the PC to Use a Static IP Address	158

Configuring the PC to Use Auto-IP

To set up the a TEMPpoint, VOLTpoint, or MEASURpoint instrument when the LAN does not support a DHCP server and your PC is configured to use a static IP address, you must temporarily reconfigure the PC to use Auto-IP by performing the following steps:

Note: This procedure may differ slightly depending on your computer and the version of Windows you are using. Windows XP instructions are shown here.

1. From the Windows Start menu, click **Settings**, and then click **Network Connections**.
2. Right-click **Local Area Connection**, and select **Properties**.

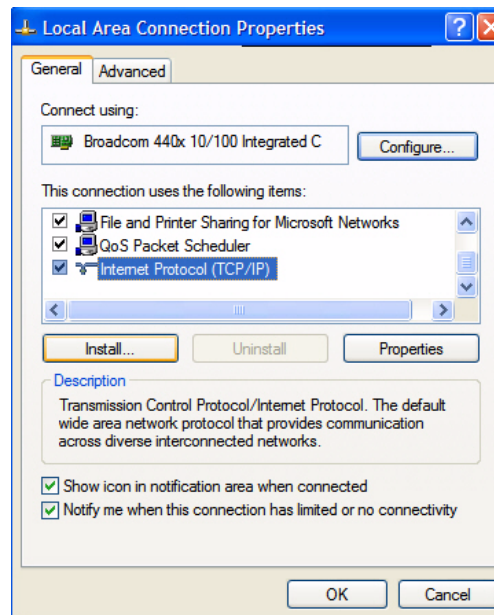

3. In the General tab window, double-click **Internet protocol (TCP/IP)**. (If a TCP/IP selection is not listed, click **Install**, select **Protocol**, click **Add**, select the TCP/IP protocol, and click **Install**, and repeat step 3).

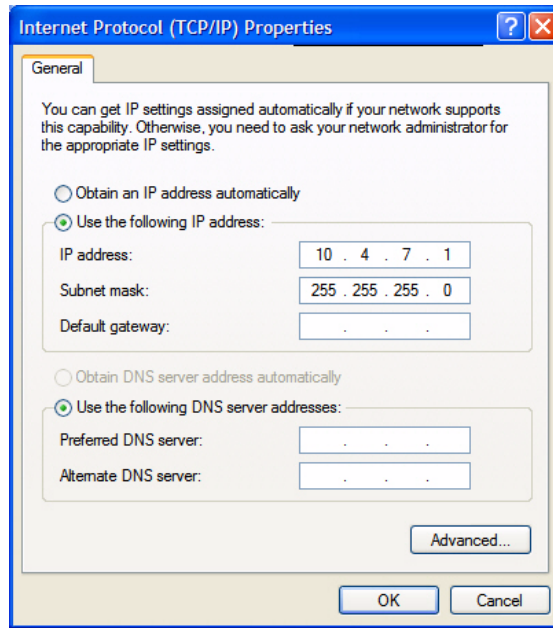

4. **IMPORTANT:** Write down the IP address and subnet mask that is displayed! You will need this information later.
5. Select **Obtain an IP address automatically**, and then click **OK**.

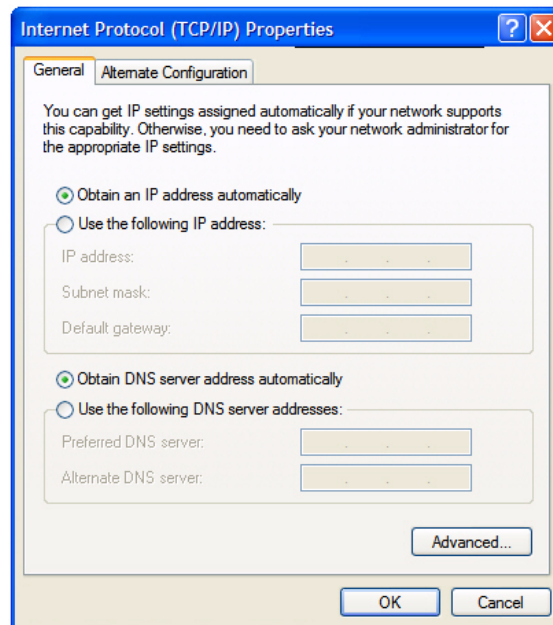

6. Select the **Alternate Configuration** tab, and ensure that **Automatic private IP address** is selected.

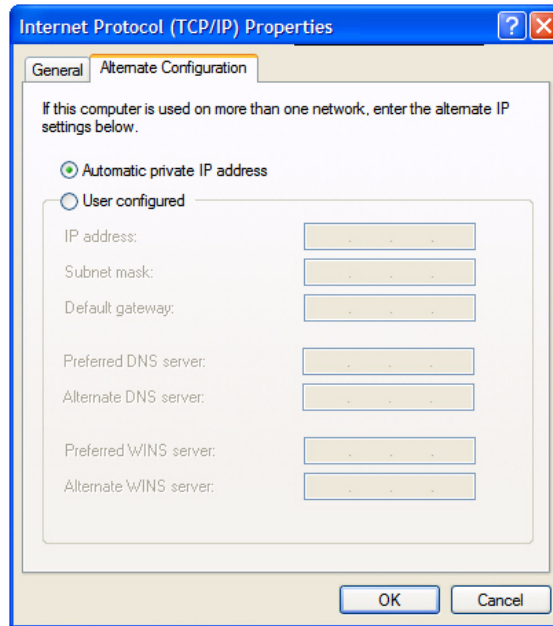

7. Renew the IP address of the computer. From the Windows Start menu, click **Settings** -> **Network Connections** -> **Local Area Connection** -> **Support** -> **Repair**.

Or, if you prefer to do this from the command prompt window, click **Run** from the Windows Start menu, enter **cmd**, and click **OK** to bring up the command prompt window. Then, from the command prompt window, enter:

```
ipconfig /renew  
ipconfig /all
```

renews the IP address
checks the IP address

Specifying a Static IP Address for your Instrument

To specify a static IP address for your TEMPpoint, VOLTpoint, or MEASURpoint instrument, use the LAN Configuration page of the web interface as follows:

1. From the LAN Configuration page, click **Modify**.
2. Specify the username as **sysadmin**, and specify the password (the default password is **user**). You can change the password, if you desire.
3. Uncheck the checkbox called **Automatic private IP address enabled**.
4. Click **Static**.
5. Specify a static IP address for the instrument, so that it will be on the same subnet as your PC:

DATA TRANSLATION® TEMPpoint **LXI**

DT8872 LAN Configuration

Home
Configuration
 LAN
 Channel
 Scan rate
 Filter
 Limits
 Digital In
 Digital Out
Control
 Scan
 Digital Output
Measurements
 Channel
 Digital Input
File
 Download Measurements
Help
 Topics
 Technical Support

Save configuration Discard changes [Help](#)

Item	Value										
Hostname	DT8872										
Description	This TEMPpoint box is located in the SQA lab.										
	<input type="radio"/> DHCP <input type="checkbox"/> Automatic private IP address enabled <input checked="" type="radio"/> Static Static IP Address configuration										
IP address assignment	<table border="1"> <tr> <td>10.4.7.2</td> <td>IP</td> </tr> <tr> <td>255.255.255.0</td> <td>Mask</td> </tr> <tr> <td>192.168.187.218</td> <td>Gateway</td> </tr> <tr> <td></td> <td>Primary DNS</td> </tr> <tr> <td></td> <td>Secondary DNS</td> </tr> </table>	10.4.7.2	IP	255.255.255.0	Mask	192.168.187.218	Gateway		Primary DNS		Secondary DNS
10.4.7.2	IP										
255.255.255.0	Mask										
192.168.187.218	Gateway										
	Primary DNS										
	Secondary DNS										
Primary SNTP server	192.43.244.18										
Secondary SNTP server	132.163.4.101										
Password	user										
MAC address	00:40:9D:43:35:97										

Note: You need a Simple Network Time Protocol (SNTP) time server on the LAN; otherwise, you need to provide a gateway. See your network administrator for more details.

Reconfiguring the PC to Use a Static IP Address

After you have set up your instrument, you can reconfigure your PC to use a static IP address using this procedure:

1. From the Windows Start menu, click **Settings**, and then click **Network Connections**.
2. Right-click **Local Area Connection**, and select **Properties**.
3. In the General tab window, double-click **Internet protocol (TCP/IP)**.
4. Select **Use the following IP address:**, specify the static IP address and subnet mask that was initially assigned to the PC (see [page 154](#)), and click **OK**.

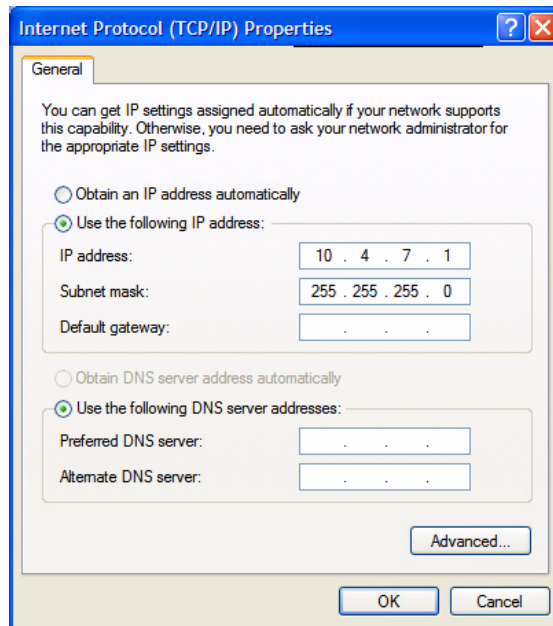

5. Renew the IP address of the computer. From the Windows Start menu, click **Settings** -> **Network Connections** -> **Local Area Connection** -> **Support** -> **Repair**.

Or, if you prefer to do this from the command prompt window, click **Run** from the Windows Start menu, enter **cmd**, and click **OK** to bring up the command prompt window. Then, from the command prompt window, enter:

```
ipconfig /renew           renews the IP address  
ipconfig /all            checks the IP address
```



About ISO-Channel Technology

ISO-Channel Technology.....	160
Why ISO-Channel Technology is Your Best Return On Investment.....	161
Floating Signal Inputs Offer New Application Advantages	167

ISO-Channel Technology

All TEMPpoint, VOLTpoint, and MEASURpoint products use ISO-Channel™ technology to eliminate common mode noise and ground loop problems.

This appendix includes two white papers that describe the benefits of using ISO-Channel technology.

Why ISO-Channel Technology is Your Best Return on Investment

When connecting signal sources to an instrument, it is important to eliminate the sources of error that can contribute to inaccuracies in your measurements. In most measurement instruments, this burden is on the customer. Instruments that use ISO-Channel technology, however, solve this problem for you – saving you tremendous setup and debug time and reducing costly grounding problems when connecting signals.

In today's economy, we understand that every equipment decision needs to make good fiscal sense. This section describes why instruments with ISO-Channel technology offer you the best return on investment.

Understanding Ground Loops

When measuring signals, users often assume that the grounds of their signals and their measurement system are at the same potential. However, these ground potentials can differ by hundreds of millivolts.

If the difference in ground potential is large enough, current flows between the signal and your measurement system; this is called a ground loop (see [Figure 40](#)). Ground loops contribute noise that can greatly affect the accuracy of your measurements, especially when you are trying to measure low level signals precisely. Ground loop problems are the most common source of error in all measurements! Eliminating these errors, therefore, is critical when taking high accuracy measurements.

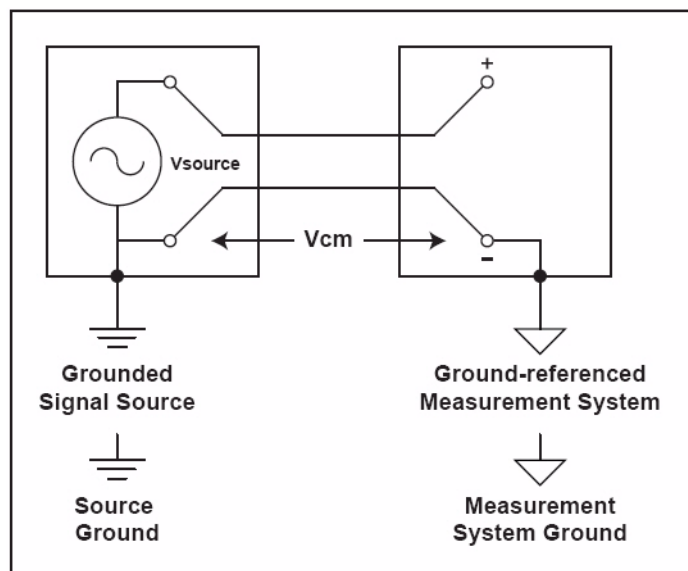

When a ground loop exists, the measured voltage, V_{out} , is the sum of the signal voltage, V_{source} , and the ground potential difference, V_{cm} , which exists between the signal source ground and the measurement system ground. These errors often appear as transients or periodic signals in the measurement. For example, if a ground loop is formed with 50 Hz or 60 Hz AC power lines, the unwanted AC signal appears as a periodic voltage error in the measurement.

Figure 40: Measurement System with a Ground Loop

ISO-Channel Eliminates Ground Loops and Increases Common-Mode Rejection

ISO-Channel technology eliminates ground loop problems by using a **differential, isolated, floating front-end**. As you can see in [Figure 41](#), a floating voltage signal is not referenced to system ground.

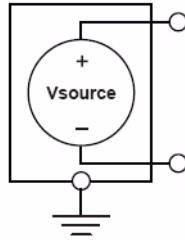

Figure 41: Floating Signals

To measure floating signal sources, ISO-Channel technology uses differential analog input signals, a 24-bit Delta-Sigma A/D converter for each channel, and channel-to-channel isolation, as shown in [Figure 42](#).

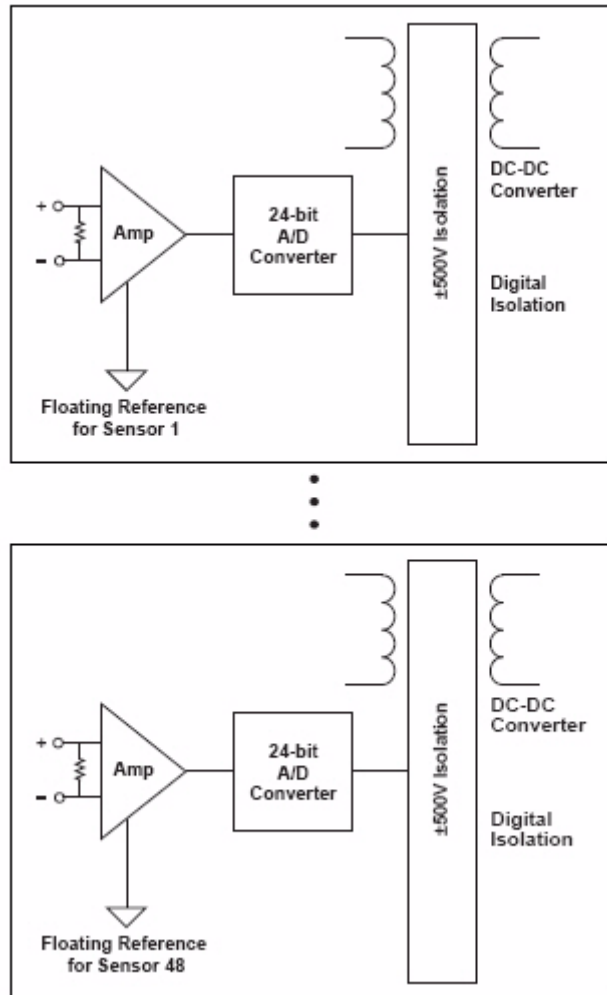

Figure 42: ISO-Channel Technology

Floating, Differential Signals

ISO-Channel technology implements a virtually ideal differential measurement system that reads only the potential difference between the positive and negative terminals of the amplifier. For each channel, the differential signals are isolated in that they are referenced to a ground reference point that is not connected to earth ground. Ground loop problems are eliminated by ensuring that only one ground reference is used for each channel in the measurement system. The signal sources are isolated from each other and from the measurement instrument.

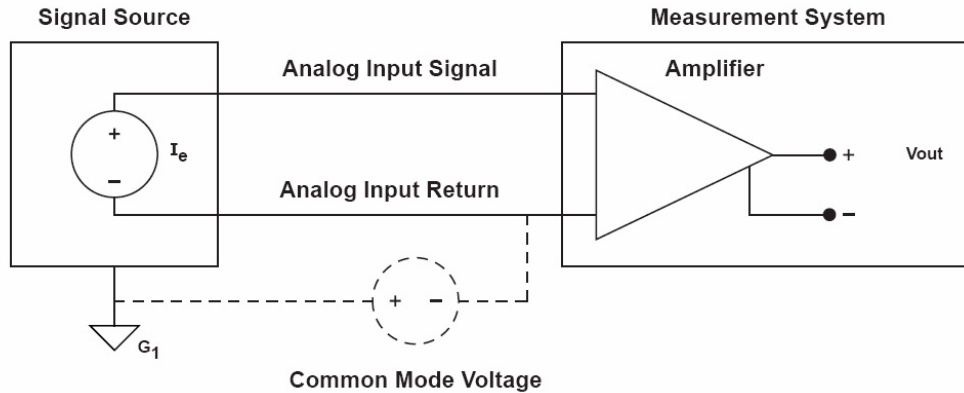

Figure 43: Differential Signals and Common-Mode Voltage

When the measurement instrument and signal source are at different ground potentials, the difference in potential is called common-mode voltage. The measurement instrument cannot discern between the signal and the common-mode voltage believing that the sum of these voltages is the actual signal. Of course, the common-mode potential is simply an error.

ISO-Channel technology provides common-mode rejection of 150 dB, which contributes an almost imperceptible error (33.5 million to 1) to V_{out} . Compare this to traditional data acquisition measurement instruments, which typically provide only 80 dB of common-mode rejection and therefore, contribute much more error on the order of 1 part per 10,000.

Simultaneous Architecture

Many measurement instruments on the market today provide multiplexed architectures, where one A/D is used to measure multiple channels. In this kind of architecture, if one channel goes down, all channels go down.

ISO-Channel technology, on the other hand, uses a simultaneous architecture, where each channel has its own dedicated 24-bit Delta-Sigma A/D, as shown in [Figure 44](#).

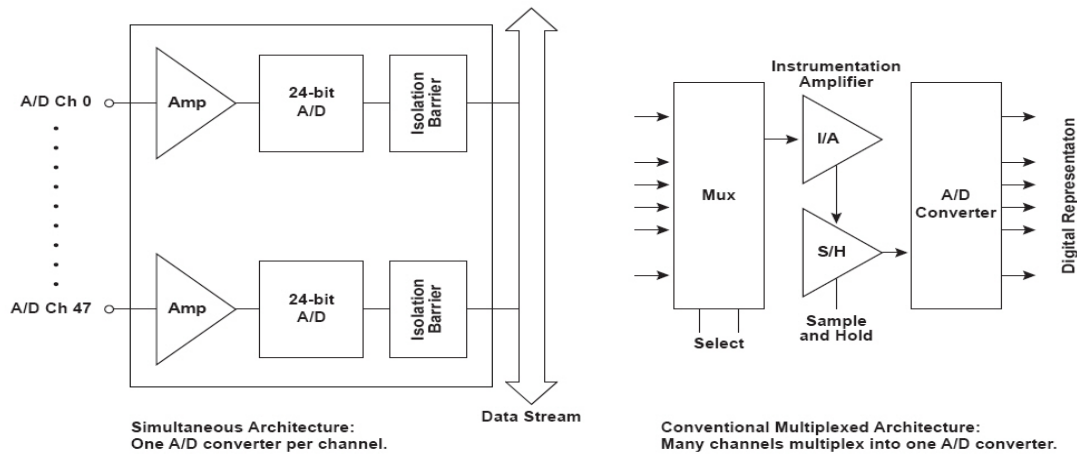

Figure 44: Simultaneous vs. Multiplexed Architectures

Channel-to-Channel Isolation

Besides differential inputs, floating channels, and a simultaneous architecture, ISO-Channel technology provides channel-to-channel isolation, not just isolation from the analog front-end to the computer ground. With this kind of isolation, the channels are individually isolated from each other and from other system components.

Typically, instrument manufacturers have used relays, isolation amplifiers, or optical isolation to provide channel-to-channel isolation. These methods have the following advantages and limitations:

- Relays – This technology provides good galvanic separation and can provide good accuracy and thermal properties, but relays are slow as they operate on one channel at a time (10 cycles/s), wear out over time, and are sensitive to magnetic fields. If one relay sticks, staying closed, the entire system fails!
- Isolation amplifiers – Isolation amplifiers are used in multiplexed architectures. While they are solid-state, they are expensive, not as accurate, require more power, and generate more noise and heat than other solutions.
- Optical isolation - Optical isolation is good in digital isolation systems but causes accuracy problems in analog isolation systems. It is also subject to long-term drift and requires considerably more power.

With ISO-Channel technology, the A/D is on the sensor side and has its own custom DC/DC converter. Then, optical or transformer isolation is used to transfer the A/D output data (the sensor data) **digitally**. And, due to the simultaneous architecture of ISO-Channel technology, all data is transferred in parallel.

Summary

ISO-Channel technology offers built in system redundancy to protect your investment - if one channel fails, the remaining channels are completely unaffected! Instruments with ISO-Channel technology also adapt to the sensors that they are connected to, allowing a different ground reference for each signal without introducing errors! For these key reasons, ISO-Channel technology protects against problems in the field, and thereby, reduces costs – what a great return on your investment.

Floating Signal Inputs Offer New Application Advantages

Precision measurement systems are often limited in that all inputs are connected to a single ground. Typically, multiplexer input configurations are set up this way, since all signal inputs are connected to the same return. Even differential input configurations use the same ground reference. The result is that accuracy and flexibility for accurate measurements can be severely compromised when noise or common mode voltage is present (see [Figure 45](#)).

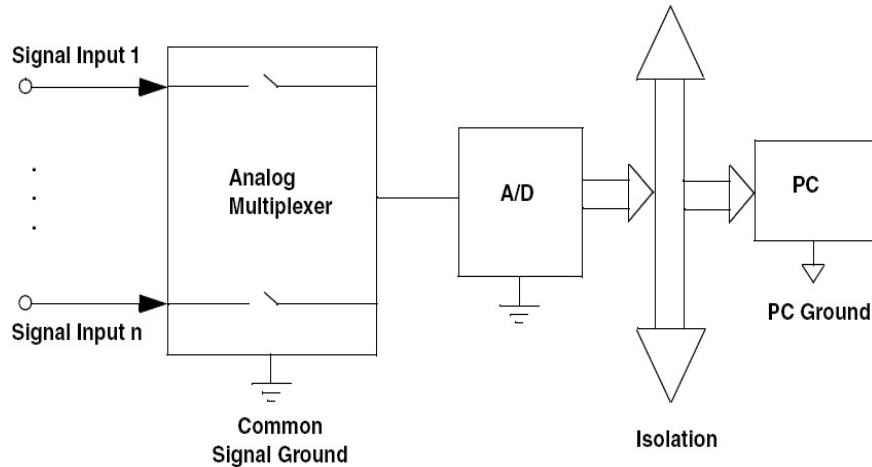

Figure 45: In multiplexed systems, all inputs are connected to a signal ground, which can cause errors when noise or common mode voltage is present.

Crosstalk from one input signal can easily be reflected onto another input. The design movement to an A/D per channel can help this problem. But that is not sufficient in many cases (see [Figure 46](#)).

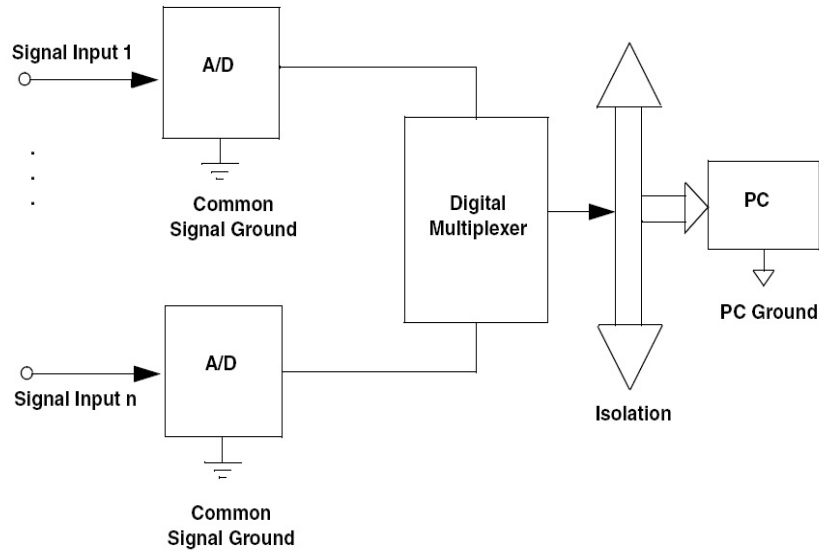

Figure 46: Even when using an A/D per channel, noise can contribute errors to your measurement results.

To minimize noise and ground loops, some newer systems offer isolation between the input signal ground reference and the computer ground. This effectively separates the computer ground from the measurement portion of the system. But still, there is no isolation between input sensor channels, which is a common source of error and frustration for user applications. Why?

The assumption is made that all signal sources have the same exact ground reference. After all...ground is ground...isn't it? Often this is not the case. For example, thermocouples for measuring temperature may be dispersed widely throughout an industrial setting, such as in the manufacture of air frames or in curing ovens. Grounds for these sensors may differ by several volts or even hundreds of volts. The resulting common mode voltage causes current to flow in the signal path, producing serious errors, which are very hard to diagnose and correct.

Isolating Each Input

Oftentimes it is NOT apparent that ground references from various sensors such as thermocouples, RTDs, strain gages, etc., are at different voltage potentials. Factors that can contribute to these ground differences are extensive wiring from long runs, crosstalk from motors or generators, or high source impedance from the signal source. Without recognizing this extraneous voltage, the measurement system "sees" this noise or common mode voltage as the actual signal. These unwanted noise sources lead to measurement errors (see [Figure 47](#)).

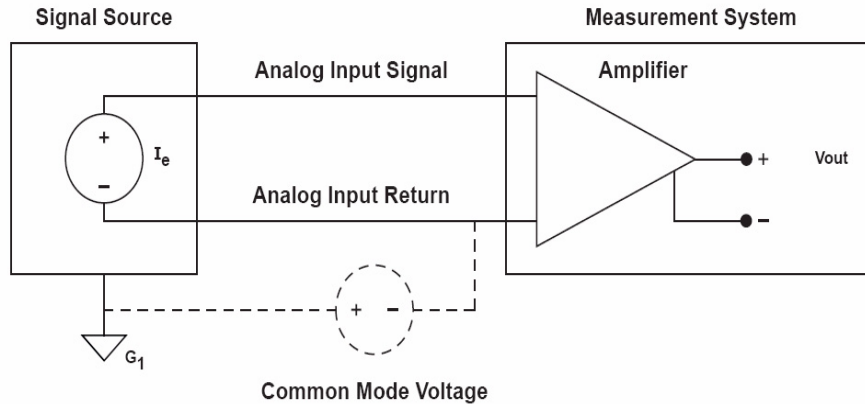

Figure 47: Common mode voltage is present when different ground potentials exist in your measurement system.

In many applications, noise is a fact and a common occurrence. To prevent this noise from entering the signal path, the signal must be isolated on a channel-to-channel basis as well as from the PC ground reference.

Technology breakthroughs now allow channel-to-channel isolation to be accomplished effectively. Using an A/D per channel with a DC-DC converter for each A/D allows each signal input channel to be isolated from one another (see [Figure 48](#)). With this individual isolation per channel, each input channel can now “float” to its own ground reference. Separate channels are then effectively isolated from each other by the isolation barrier, up to ± 500 V for each channel. Now any noise or common mode voltage to that level is eliminated from the system measurement, allowing pristine results from each sensor without any interaction from any other sensor.

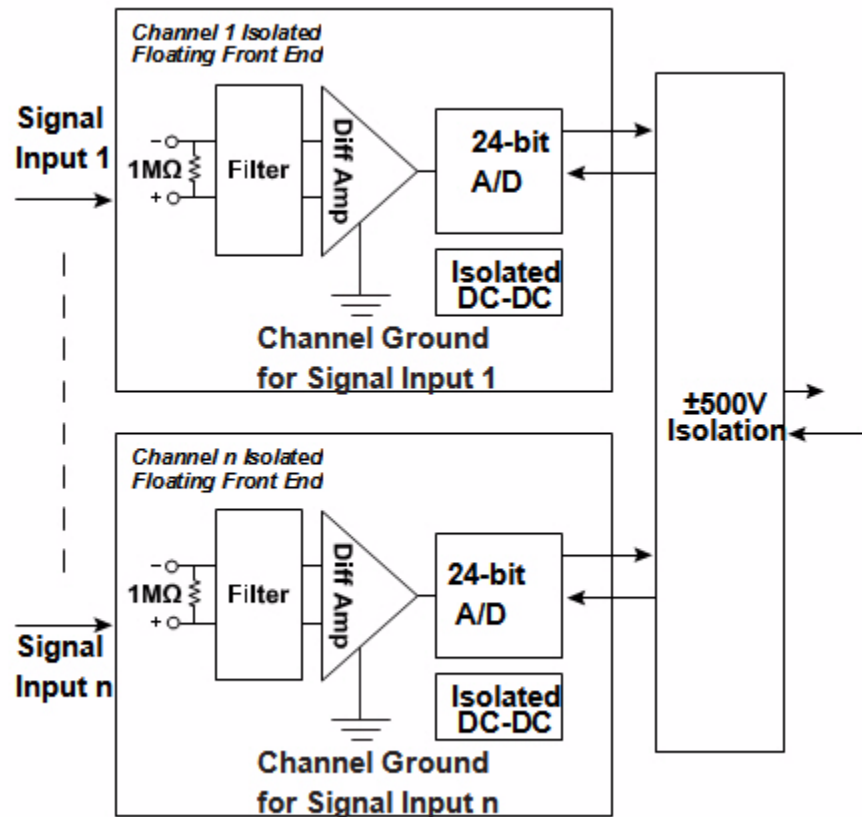

Figure 48: An A/D per channel and a DC-to-DC converter for each A/D provides channel-to-channel isolation, where each signal can float to its own ground reference.

Input channel return references are effectively separate instruments when the inputs are isolated. This individual isolation now allows the ground reference of each channel to measure at the level of this common mode voltage, up to ± 500 V. This capability allows some new application ideas to flourish.

Measurement of two signals, as shown in [Figure 49](#), can now have essentially 3 separate ground references: each signal input (signal 0 and signal 1) has a separate return reference; additionally, the PC has a third ground reference. This scheme can be extended for many signal inputs, such as 48 inputs in a single small measurement box, for a total of 49 different ground references.

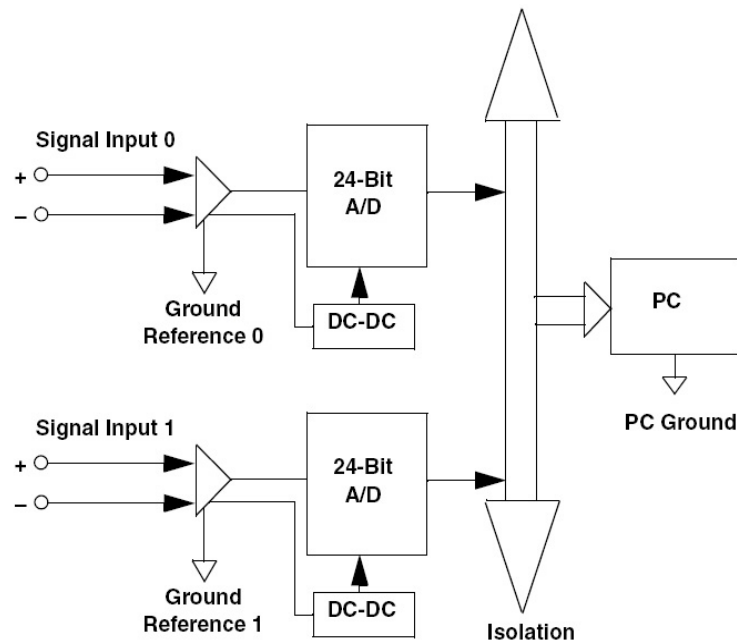

Figure 49: When measuring two input signals with channel-to-channel isolation, three ground references are provided (signal 0, signal 1, and PC ground).

New Application Derived from Isolated Channels

A typical application of measuring 48 channels of varying voltages from sensors, such as batteries, thermocouples, RTDs pressure sensors, etc., often must use different instruments because of the various ranges needed. Standard ranges of ± 10 V may handle some applications, but not others, to the required resolution and accuracy.

With isolation per channel, combinations of channels can be used to measure higher voltage ranges. [Figure 50](#) shows a configuration of 2 separate channels “ganged up” to measure a signal of up to 20 V. Normally each input would measure ± 10 V. But, by using two identical channels, a range of twice that level can be accommodated. The output readings of each A/D are then summed to give the very accurate result. This is possible because the isolation between channels allows the return of the first channel to “float up” to a level halfway between the input signal. This reflects the accurate impedance balance of each input, and the high common mode rejection of each stage.

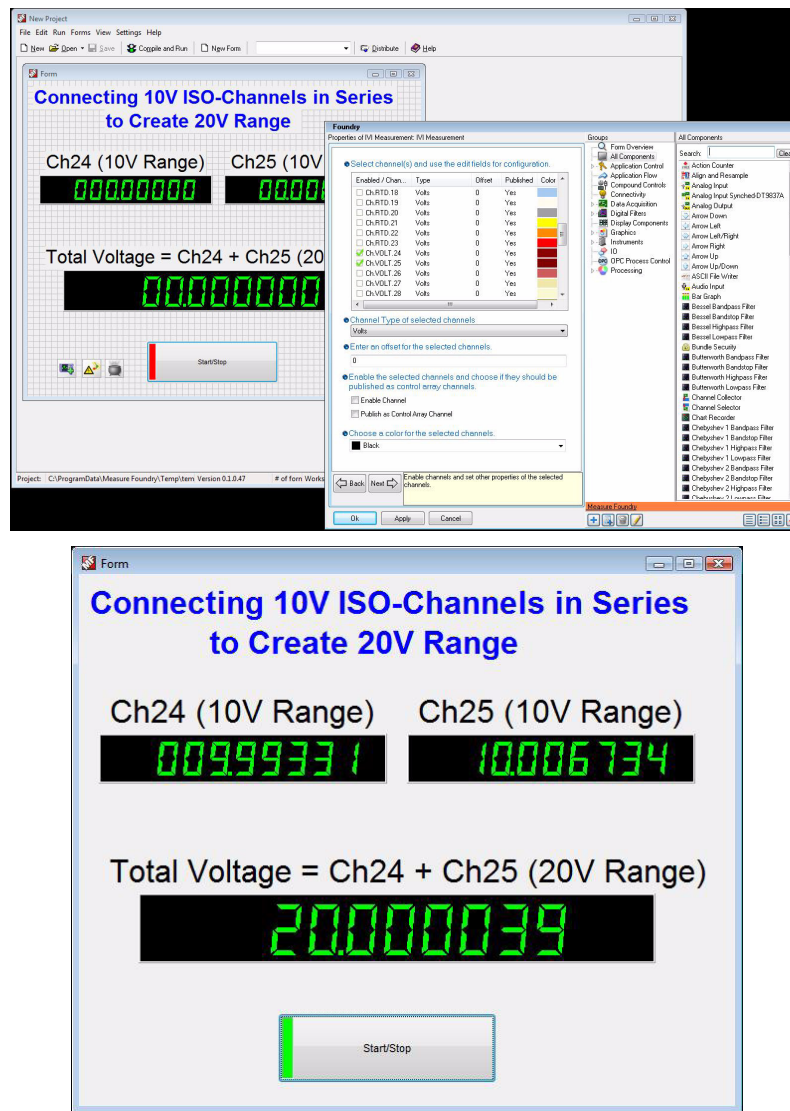

Figure 50: Because each floating signal input is isolated from each other, you can use two separate channels, normally each configured for $\pm 10\text{V}$, to measure a $\pm 20\text{V}$ signal. Simply sum the result of each channel to get your result.

Summary

When you need the highest accuracy and the most flexibility from your measurement system, ensure that floating signal inputs are provided. This approach allows noise-free measurements in tough industrial settings. It also saves countless days of tracking down erroneous readings that inevitably result if these precautions are not taken from the project's beginning.

Index

A

- accessories 22
- accuracy specifications, thermocouple 121, 123
- Active Scripting 68
- activity, Ethernet LED 43
- address string 42
- Agilent VISA 31
- alarm limit configuration 82
- alias, VISA 42
- alpha curves 125
- analog input 99
 - basic instrument specifications 120
 - calibration 104
 - channels 99
 - CJC circuit 101
 - configuration 79
 - conversion modes 105
 - data format for high voltage channels 108
 - data format for RTD channels 108
 - data format for thermocouple channels 108
 - differential configuration 49, 51
 - error conditions 108
 - filtering 107
 - input ranges 102
 - open thermocouple detection 101
 - out of range data 103, 104
 - resolution 104
 - RTD specifications 125
 - RTD types 102
 - sample clock 105
 - thermocouple specifications 121
 - thermocouple types 100
 - trigger source 105
 - wiring current loop inputs to high voltage channels 60
 - wiring current loop inputs to RTD channels 59
 - wiring current loop inputs to thermocouple channels 58
 - wiring RTD inputs 51
 - wiring thermocouple inputs 49
 - wiring voltage inputs to high voltage channels 56
 - wiring voltage inputs to RTD channels 56
 - wiring voltage inputs to thermocouple channels 55
- application wiring
 - current loop inputs to high voltage channels 60

- current loop inputs to RTD channels 59
- current loop inputs to thermocouple channels 58
- digital inputs 63
- digital outputs 63
- RTD inputs 51
- thermocouple inputs 49
- voltage inputs to high voltage channels 56
- voltage inputs to RTD channels 56
- voltage inputs to thermocouple channels 55

applying power 40

associating CSV files 71

attaching the module to the computer 37

Auto-IP 38, 42, 154

B

- block diagrams 94
 - DT8871 95
 - DT8871U 94
 - DT8872 96
 - DT8873 97
 - DT8874 98

C

- cables 37
 - crossover 39
 - standard LAN (EP372) 38
- calibration 104
- channel-to-channel isolation 111
- CJC circuit 101
- clients 67
- clocks, analog input 105
- cold junction compensation 101
- configuring
 - alarm limits 82
 - analog input channels 79
 - digital inputs 83
 - digital outputs 84
 - filters 81
 - LAN 78
 - scan rate 80
 - triggers 83
- configuring network settings on PC 153
- connecting signals
 - current loop inputs to high voltage channels 60
 - current loop inputs to RTD channels 59

- current loop inputs to thermocouple channels 58
- digital inputs 63
- digital outputs 63
- RTD inputs 51
- thermocouple inputs 49
- voltage inputs to high voltage channels 56
- voltage inputs to RTD channels 56
- voltage inputs to thermocouple channels 55
- connecting to the LAN 37
 - private LAN 38
 - site LAN 37
- connector pin assignments
 - digital I/O connector 137
 - Ethernet connector 135
- continuous analog input 106
- conversion modes 105
 - continuous analog input (scan mode) 106
 - digital I/O 111
 - simultaneous single-value analog input 106
- conversion rate 107
- crossover cable 39
- CSV files 71
- customer service 117

D

- data encoding 108
- data format
 - high voltage channels 108
 - RTD channels 108
 - thermocouple channels 108
- DHCP server 37, 38, 42
- differential channels 49, 51
- digital I/O
 - channel-to-channel isolation 111
 - connecting input signals 63
 - connecting output signals 63
 - connector pin assignments 137
 - controlling the outputs 87
 - input configuration 83
 - lines 110, 111
 - operation modes 111
 - output configuration 84
 - reading the digital input port in the analog data stream 106
 - reading the inputs 88
 - resolution 111
 - specifications 131
 - subsystem specifications 131
- digital trigger 105
- discovery utility, Eureka 20, 31, 72

- DNS server 42
- downloading measurements 89

E

- encoding data 108
- ENet Activity LED 43
- ENet Link LED 43
- environmental specifications 132
- EP333 cable assembly 22, 62
- EP372 LAN cable 38
- error conditions 108
- Ethernet activity 43
- Ethernet cable 37, 38
- Ethernet connector specifications 135
- Ethernet crossover cable 39
- Eureka Discovery Utility 20, 31
 - firewall settings 73
 - installing 31
 - running 72
 - troubleshooting 73
 - using 72
- Excel 71
 - opening a data file 149
 - using to display data 90
- external digital trigger 105

F

- factory service 117
- features 16
- FIFO 107
- filters 81, 107
- floating-point data 108
- formatting data
 - high voltage channels 108
 - RTD channels 108
 - thermocouple channels 108
- frequency 105

G

- GMT 77

H

- hardware features 16
- high drive digital outputs 64
- host name 42

hub
 using with a private LAN 38
 using with a site LAN 37

I

input ranges 102
 installing the software 31
 Eureka Discovery Utility 31
 IVI-COM driver 31
 Measurement Application 31
 prerequisites 31
 SCPI support 32
 instrument web interface 20
 Internet Explorer browser settings 67
 JavaScript 68
 pop-up blockers 70
 security levels 68
 Internet zone 68
 Intranet zone 69
 IP address 42
 ISO-Channel technology 159
 isolation 111
 isolation specifications 126
 IVI-COM driver 20
 installing 31

J

Java 67

L

LAN
 configuration 78
 connecting to a private LAN 38
 connecting to a site LAN 37
 LED 43
 launching the web interface 76
 LEDs
 ENet Activity 43
 ENet Link 43
 LAN 43
 LMT 43, 103, 104
 OPN 43, 101, 103
 Power 40
 USB 43
 limit configuration 82
 lines, digital I/O 110, 111
 LMT LED 43, 103, 104
 logging data to disk 148

M

Measure Foundry 20
 Measurement Application 20
 configuring 144
 defining alarm limits 146
 exiting 152
 features 140
 installing 31
 logging data to disk 148
 opening a data file in Excel 149
 reading the digital input lines 151
 running 141
 updating the digital output lines 147
 using the Chart Recorder 148
 viewing a data file 150
 Measurement Instrument Calibration Utility 21
 mechanical relays, controlling 64
 memory specifications 127
 Microsoft Excel 71
 Microsoft Notepad 71
 moving average filter 107

N

network settings 153
 NI-VISA 31
 Notepad 71

O

open thermocouple detection 101
 operation modes
 continuous analog input (scan mode) 106
 digital I/O 111
 simultaneous single-value analog input 106
 OPN LED 43, 101, 103
 opto-isolators 110
 out of range data
 high voltage channels 104
 RTD channels 104
 thermocouple channels 103

P

password 79
 physical specifications 132
 pinging the instrument 114, 115
 pop-up blockers 70
 power
 applying 40
 specifications 132

- prerequisite software 31
- private LAN 38
 - connecting directly to a computer 39
 - connecting using a hub or switch 38
- protection specifications 126

R

- rack mounting 22
- raw filter 107
- recommendations for wiring 47
- recording data 148
- regulatory specifications 133
- requirements 30
- requirements for web interface 67
 - associating CSV files 71
 - Internet Explorer browser settings 67
 - Java 67
- Reset pin 44
- resetting the instrument 44
- resolution
 - analog input 104
 - digital I/O 111
- returning boards to the factory 117
- RJ45 connector specifications 135
- RMA 117
- router
 - using with a site LAN 37
- RTD alpha curves 125
- RTD channels
 - data format 108
- RTD connections
 - 2-wire 53
 - 3-wire 52
 - 4-wire 52
- RTD connector specifications 134
- RTD specifications 125
- RTD types 102

S

- sample clock 105
- sample rate 107
- scan rate 80
- SCPI
 - clients 67
 - installing 32
 - programming 21
- security levels 68
 - Internet zone 68
 - Intranet zone 69

- Trusted Site zone 70
- SENSOR_IS_OPEN 102
- simultaneous single-value analog input 106
- site LAN 37
 - connecting using a hub, switch, or router 37
 - connecting without using a hub, switch, or router 38
- software packages 20
- software trigger 105
- solid-state relays 111
 - controlling 64
- sourcing 64
- specifications 119, 153
 - basic instrument 120
 - digital I/O 131
 - environmental 132
 - Ethernet connector 135
 - isolation and protection 126
 - memory 127
 - physical 132
 - power 132
 - regulatory 133
 - RJ45 connector 135
 - RTD 125
 - RTD connectors 134
 - system temperature error 121, 123
 - temperature stability 128
 - thermocouple 121
 - thermocouple connectors 134
 - voltage connectors 134
 - voltage measurement 129
- static IP addresses 78, 154, 158
- STP37 screw terminal panel 22, 62
- switch
 - using with a private LAN 38
 - using with a site LAN 37
- system requirements 30
- system temperature error 121, 123

T

- TCP/IP configuration 42
- technical support 116
- temperature error 121, 123
- temperature stability specifications 128
- thermocouple accuracy specifications 121, 123
- thermocouple channels
 - data format 108
- thermocouple connector specifications 134
- Thermocouple Open LED 43
- thermocouple types 100

time zone [77](#)
trigger source [105](#)
 external [105](#)
 software [105](#)
triggers [83](#)
troubleshooting
 procedure [114](#)
 technical support [116](#)
 troubleshooting table [114](#)
Trusted Site zone [70](#)

U

unpacking [29](#)
USB LED [43](#)
username [79](#)
UTC [77](#)

V

VISA alias [42](#)
VISA resource string [42](#)
voltage connector specifications [134](#)
voltage measurement specifications [129](#)
VXI-11 clients [67](#)

W

warm-up time [48](#)
web interface [20](#), [76](#)
 alarm limit configuration [82](#)
 analog input channel configuration [79](#)
 clients [67](#)
 controlling the digital outputs [87](#)
 digital input and trigger configuration [83](#)
 digital output configuration [84](#)
 downloading measurements [89](#)
 filter configuration [81](#)
 LAN configuration [78](#)
 measurement and controlling the instrument [85](#)
 reading the digital inputs [88](#)
 requirements for using [67](#)
 scan rate configuration [80](#)
 starting and stopping a scan [85](#)
wiring signals
 current loop inputs to high voltage channels [60](#)
 current loop inputs to RTD channels [59](#)
 current loop inputs to thermocouple channels [58](#)
 digital inputs [63](#)
 digital outputs [63](#)
 recommendations [47](#)

RTD inputs [51](#)
thermocouple inputs [49](#)
voltage inputs to high voltage channels [56](#)
voltage inputs to RTD channels [56](#)
voltage inputs to thermocouple channels [55](#)
warm-up time [48](#)

Z

zones
 Internet [68](#)
 Intranet [69](#)
 Trusted Site [70](#)

