

TREK-550 TREK-303

In-Vehicle Computing Box
Smart Display
User manual

Trusted ePlatform Services

ADVANTECH

Copyright

The documentation and the software included with this product are copyrighted 2010 by Advantech Co., Ltd. All rights are reserved. Advantech Co., Ltd. reserves the right to make improvements in the products described in this manual at any time without notice. No part of this manual may be reproduced, copied, translated or transmitted in any form or by any means without the prior written permission of Advantech Co., Ltd. Information provided in this manual is intended to be accurate and reliable. However, Advantech Co., Ltd. assumes no responsibility for its use, nor for any infringements of the rights of third parties, which may result from its use.

Acknowledgements

Intel and Atom are trademarks of Intel Corporation. Microsoft Windows and MS-DOS are registered trademarks of Microsoft Corp. All other product names or trademarks are properties of their respective owners.

Product Warranty (2 years)

Advantech warrants to you, the original purchaser, that each of its products will be free from defects in materials and workmanship for two years from the date of purchase.

This warranty does not apply to any products which have been repaired or altered by persons other than repair personnel authorized by Advantech, or which have been subject to misuse, abuse, accident or improper installation. Advantech assumes no liability under the terms of this warranty as a consequence of such events.

Because of Advantech's high quality-control standards and rigorous testing, most of our customers never need to use our repair service. If an Advantech product is defective, it will be repaired or replaced at no charge during the warranty period. For out-of-warranty repairs, you will be billed according to the cost of replacement materials, service time and freight. Please consult your dealer for more details.

If you think you have a defective product, follow these steps:

1. Collect all the information about the problem encountered. (For example, CPU speed, Advantech products used, other hardware and software used, etc.) Note anything abnormal and list any onscreen messages you get when the problem occurs.
2. Call your dealer and describe the problem. Please have your manual, product, and any helpful information readily available.
3. If your product is diagnosed as defective, obtain an RMA (return merchandise authorization) number from your dealer. This allows us to process your return more quickly.
4. Carefully pack the defective product, a fully-completed Repair and Replacement Order Card and a photocopy proof of purchase date (such as your sales receipt) in a shippable container. A product returned without proof of the purchase date is not eligible for warranty service.
5. Write the RMA number visibly on the outside of the package and ship it prepaid to your dealer.

Part No. 2010055001

Printed in Taiwan

Edition 1

June 2010

Declaration of Conformity

This product has passed the CE test for environmental specifications. Test conditions for passing included the equipment being operated within an industrial enclosure. In order to protect the product from being damaged by ESD (Electrostatic Discharge) and EMI leakage, we strongly recommend the use of CE-compliant industrial enclosure products.

FCC Class B

Note: This equipment has been tested and found to comply with the limits for a Class B digital device, pursuant to part 15 of the FCC Rules. These limits are designed to provide reasonable protection against harmful interference in a residential installation. This equipment generates uses and can radiate radio frequency energy and, if not installed and used in accordance with the instructions, may cause harmful interference to radio communications. However, there is no guarantee that interference will not occur in a particular installation. If this equipment does cause harmful interference to radio or television reception, which can be determined by turning the equipment off and on, the user is encouraged to try to correct the interference by one or more of the following measures:

- Reorient or relocate the receiving antenna.
- Increase the separation between the equipment and receiver.
- Connect the equipment into an outlet on a circuit different from that to which the receiver is connected.
- Consult the dealer or an experienced radio/TV technician for help.

Technical Support and Assistance

1. Visit the Advantech web site at www.advantech.com/support for the latest information about the product.
2. Contact the distributor, sales representative, or Advantech's customer service center for technical support if you need additional assistance. Please have the following information ready before you call:
 - Product name and serial number
 - Description of your peripheral attachments
 - Description of your software (operating system, version, application software, etc.)
 - A complete description of the problem
 - The exact wording of any error messages

Warnings, Cautions and Notes

Warning! Warnings indicate conditions, which if not observed, can cause personal injury or death.



Caution! Cautions are included to help you avoid damaging hardware or losing data. e.g.

Note! Notes provide optional additional information.



Document Feedback

To assist us in making improvements to this manual, we would welcome comments and constructive criticism. Send all such in writing to: support@advantech.com

Packing List

Before setting up, check that the items listed below are included, in good condition. If any item does not accord with the table, please contact your dealer immediately.

- TREK-550 series In-Vehicle Computing Box
- USB/Audio Cable clip
- Warranty card
- Power cord: DC power inlet cable (180 cm - for TREK-550 only)
- Video in/CAN cable
- "Drivers, Utilities and User Manual" CD-ROM
- End User License Agreement (XPE and WinCE model), please download driver and related document from www.advantech.com/support

Ordering information

P/N	Description
TREK-550-GA0E	Intel Atom Z510PT 1.1Ghz , GPS, GPRS module built in
TREK-550-HA0E	Intel Atom Z510PT 1.1Ghz , GPS, HSDPA module built in
TREK-550-CA0E	Intel Atom Z510PT 1.1Ghz , GPS, CDMA module built in
TREK-550-GXPEA0E	Intel Atom 1.1 GHz, GPS, GPRS, 1GB DDR, 4GB CF, WinXPe
TREK-303R-HA0E	7" vehicle display system, 800x480 resolution, with 4 wire resistive touch screen, 2-watts speaker.
1700018342	2-meter cable(paired with TREK-5XX)

Safety Instructions

1. Read these safety instructions carefully.
2. Keep this user manual for later reference.
3. Disconnect this equipment from AC outlet before cleaning. Do not use liquid or spray detergents for cleaning.
4. For pluggable equipment, the power outlet shall be installed near the equipment and shall be easily accessible.
5. Keep this equipment away from humidity.
6. Put this equipment on a reliable surface during installation. Dropping it or letting it fall could cause damage.
7. Do not leave this equipment in an environment unconditioned where the storage temperature under -30°C (-22°F) or above 70°C (158°F), it may damage the equipment.
Operating temperature: 50°C
8. The openings on the enclosure are for air convection hence protects the equipment from overheating. **DO NOT COVER THE OPENINGS.**
9. Make sure the voltage of the power source is correct before connecting the equipment to the power outlet.
10. Place the power cord such a way that people can not step on it. Do not place anything over the power cord. The voltage and current rating of the cord should be greater than the voltage and current rating marked on the product.
11. All cautions and warnings on the equipment should be noted.
12. If the equipment is not used for long time, disconnect it from the power source to avoid being damaged by transient over-voltage.
13. Never pour any liquid into ventilation openings. This could cause fire or electrical shock.
14. Never open the equipment. For safety reasons, the equipment should be opened only by qualified service personnel.
15. If any of the following situations arises, get the equipment checked by service personnel:
 - a. The power cord or plug is damaged.
 - b. Liquid has penetrated into the equipment.
 - c. The equipment has been exposed to moisture.
 - d. The equipment does not work well or you cannot get it to work according to user manual.
 - e. The equipment has been dropped and damaged.
 - f. The equipment has obvious signs of breakage.
16. **CAUTION:** The computer is provided with a battery-powered real-time clock circuit. There is a danger of explosion if battery is incorrectly replaced. Replace only with same or equivalent type recommended by the manufacture. Discard used batteries according to the manufacturer's instructions.
17. THE COMPUTER IS PROVIDED WITH CD DRIVES COMPLY WITH APPROPRIATE SAFETY STANDARDS INCLUDING IEC 60825.

CLASS 1 LASER PRODUCT
KLASSE 1 LASER PRODUKT

18. This device complies with Part 15 of the FCC rules. Operation is subject to the following two conditions:
- (1) this device may not cause harmful interference, and
 - (2) this device must accept any interference received, including interference that may cause undesired operation.
19. **CAUTION:** Always completely disconnect the power cord from your chassis whenever you work with the hardware. Do not make connections while the power is on. Sensitive electronic components can be damaged by sudden power surges.
20. **CAUTION:** Always ground yourself to remove any static charge before touching the motherboard, backplane, or add-on cards. Modern electronic devices are very sensitive to static electric charges. As a safety precaution, use a grounding wrist strap at all times. Place all electronic components on a static-dissipative surface or in a static-shielded bag when they are not in the chassis.
21. **CAUTION:** Any unverified component could cause unexpected damage. To ensure the correct installation, please always use the components (ex. screws) provided with the accessory box.
22. Caution text concerning lithium batteries:

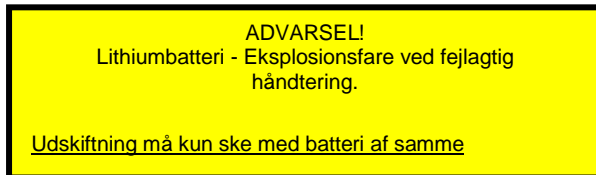

23 "Rack Mount Instructions - The following or similar rack-mount instructions are included with the installation instructions:

- A) Elevated Operating Ambient - If installed in a closed or multi-unit rack assembly, the operating ambient temperature of the rack environment may be greater than room ambient. Therefore, consideration should be given to installing the equipment in an environment compatible with the maximum ambient temperature (T_{ma}) specified by the manufacturer.
- B) Reduced Air Flow - Installation of the equipment in a rack should be such that the amount of air flow required for safe operation of the equipment is not compromised.
- C) Mechanical Loading - Mounting of the equipment in the rack should be such that a hazardous condition is not achieved due to uneven mechanical loading.
- D) Circuit Overloading - Consideration should be given to the connection of the equipment to the supply circuit and the effect that overloading of the circuits might have on over current protection and supply wiring. Appropriate consideration of equipment nameplate ratings should be used when addressing this concern.
- E) Reliable Earthing - Reliable earthing of rack-mounted equipment should be maintained. Particular attention should be given to supply connections other than direct connections to the branch circuit (e.g. use of power strips)."

Wichtige Sicherheitshinweise

1. Bitte lesen sie Sich diese Hinweise sorgfältig durch.
2. Heben Sie diese Anleitung für den späteren Gebrauch auf.
3. Vor jedem Reinigen ist das Gerät vom Stromnetz zu trennen. Verwenden Sie Keine Flüssig-oder Aerosolreiniger. Am besten dient ein angefeuchtetes Tuch zur Reinigung.
4. Die Netzanschlussteckdose soll nahe dem Gerät angebracht und leicht zugänglich sein.
5. Das Gerät ist vor Feuchtigkeit zu schützen.
6. Bei der Aufstellung des Gerätes ist auf sicheren Stand zu achten. Ein Kippen oder Fallen könnte Verletzungen hervorrufen.
7. Die Belüftungsöffnungen dienen zur Luftzirkulation die das Gerät vor überhit- zung schützt. Sorgen Sie dafür, daB diese Öffnungen nicht abgedeckt werden.
8. Beachten Sie beim. AnschluB an das Stromnetz die AnschluBwerte.
9. Verlegen Sie die Netzanschlubleitung so, daB niemand darüber fallen kann. Es sollte auch nichts auf der Leitung abgestellt werden.
10. Alle Hinweise und Warnungen die sich am Geräten befinden sind zu beachten.
11. Wird das Gerät über einen längeren Zeitraum nicht benutzt, sollten Sie es vom Stromnetz trennen. Somit wird im Falle einer Überspannung eine Beschädigung vermieden.
12. Durch die Lüftungsöffnungen dürfen niemals Gegenstände oder Flüssigkeiten in das Gerät gelangen. Dies könnte einen Brand bzw. elektrischen Schlag aus- lösen.
13. Öffnen Sie niemals das Gerät. Das Gerät darf aus Gründen der elektrischen Sicherheit nur von autorisiertem Servicepersonal geöffnet werden.
14. Wenn folgende Situationen auftreten ist das Gerät vom Stromnetz zu trennen und von einer qualifizierten Servicestelle zu überprüfen:
 15. Netzkabel oder Netzstecker sind beschädigt.
 16. Flüssigkeit ist in das Gerät eingedrungen.
 17. Das Gerät war Feuchtigkeit ausgesetzt.
18. Wenn das Gerät nicht der Bedienungsanleitung entsprechend funktioniert oder Sie mit Hilfe dieser Anleitung keine Verbesserung erzielen.
19. Das Gerät ist gefallen und/oder das Gehäuse ist beschädigt.
20. Wenn das Gerät deutliche Anzeichen eines Defektes aufweist.
21. **VORSICHT:** Explosionsgefahr bei unsachgemäßen Austausch der Batterie.Ersatz nur durch denselben oder einem vom Hersteller empfohlene-mähnlichen Typ. Entsorgung gebrauchter Batterien nach Angaben des Herstellers.
22. **ACHTUNG:** Es besteht die Explosionsgefahr, falls die Batterie auf nicht fach- männische Weise gewechselt wird. Verfangen Sie die Batterie nur gleicher oder entsprechender Type, wie vom Hersteller empfohlen. Entsorgen Sie Batterien nach Anweisung des Herstellers.
23. Der arbeitsplatzbezogene Schalldruckpegel nach DIN 45 635 Teil 1000 beträgt 70dB(A) oder weiger.

Haftungsausschluss: Die Bedienungsanleitungen wurden entsprechend der IEC-704-1 erstellt. Advantech lehnt jegliche Verantwortung für die Richtigkeit der in diesem Zusammenhang getätigten Aussagen ab.

Safety Precaution - Static Electricity

Follow these simple precautions to protect yourself from harm and the products from damage.

- To avoid electrical shock, always disconnect the power from your PC chassis before you work on it. Don't touch any components on the CPU card or other cards while the PC is on.
- Disconnect power before making any configuration changes. The sudden rush of power as you connect a jumper or install a card may damage sensitive electronic components.

Warning!



1. *Input voltage rated: 6-36 Vdc.*
2. *Transport: carry the unit with both hands and handle with care.*
3. *Maintenance: to properly maintain and clean the surfaces, use only approved products or clean with a dry applicator.*
4. *CompactFlash: Turn off the power before inserting or removing CompactFlash storage cards.*

European Contact information:

Advantech Europe GmbH Kolberger

Straße 7

D-40599 Düsseldorf, Germany

Tel: 49-211-97477350

Fax: 49-211-97477300

Contents

Chapter	1	General Information	12
1.1		Introduction	12
1.2		General Specifications	13
1.3		Dimensions	14
		Figure 1.1 TREK-550 dimensions.....	14
Chapter	2	System Setup	15
2.1		A Quick Tour of the Vehicle Mounted	16
		Figure 2.1 Front view of the TREK-550	16
		Figure 2.2 Rear side of the TREK-550	16
		Figure 2.3 Side view of the TREK-550.....	16
		Figure 2.4 Bottom view of the TREK-550.....	17
		Figure 2.5 Top view of the TREK-550.....	17
2.2		Installation Procedures.....	17
	2.2.1	Connecting the Power Cord.....	17
		Table 2.2.1: Pin Definition of Power Cord	17
	2.2.2	Power connector	18
		Figure 2.6 Power connector outlook.....	18
		Table 2.2.2: Pin Definition of Power connector.....	18
		Figure 2.7 Power connector photo.....	19
2.3		Running the BIOS Setup Program	19
2.4		Installing System Software	19
2.5		Installing the Drivers.....	19
2.6		Programming Function Keys and GPIO/CAN BUS.....	19
Chapter	3	Hardware & Peripheral Installation	20
3.1		Overview of Hardware Installation & Upgrading	21
3.2		Installing the Storage Device and Memory	21
3.3		Installing Optional Accessories	21
	3.3.1	Installing TREK-550 peripheral modules.....	21
		Figure 3.1 Install peripheral in the system.....	21
	3.3.2	Installing the MiniPCI type WWAN, SIM card & coin battery	22
		Figure 3.2 MiniPCI type WWAN, SIM card & coin battery from bottom view.....	22
	3.3.4	Installing CF card.....	22
		Figure 3.4 Installing CF card.....	23
		Figure 3.5 Installing cable lock.....	23
	3.3.5	GPS module is unable to be installed by customer	23
3.4		Paired with TREK-303 specification	23

Chapter 4 Jumper Settings and Connectors 24

4.1	Setting Jumpers and Switches.....	25
4.1.1	Locations of the Jumpers and connector.....	26
	Figure 4.1 Locations of jumpers and connectors on top side the motherboard.....	26
	Figure 4.2 Locations of jumpers and connectors on bottom side of the motherboard.....	26
	Figure 4.3 Locations of jumpers and connectors on bottom side of the daughter board.....	27
4.1.2	Jumpers.....	27
	Table 4.1.2.1: Jumpers on motherboard.....	27
	Table 4.1.2.2: Jumpers on daughter board.....	27
4.1.3	Connectors.....	28
	Table 4.1.3.1: Connectors on motherboard.....	28
	Table 4.1.3.2: Connectors on daughter board.....	28
4.2	Jumper Settings.....	29
4.2.1	CMOS Clear for External RTC (JP2).....	29
	Table 4.2.1: Clear CMOS / External RTC (JP1).....	29
4.2.2	Power Input Voltage Setting (JP1).....	29
	Table 4.2.2: Power Input Voltage Selection (JP1)	29
4.2.3	Pin 9 of COM3 Function Selection (JP3).....	29
	Table 4.2.3: Pin 9 of COM 3 Function Selection (JP3).....	29
4.2.4	Pin 9 of COM8 Function Selection (J3).....	29
	Table 4.2.4: Pin 9 of COM8 Function Selection (J3).....	29
4.2.5	DI/GPS Function Selection (SW2)	30
	Table 4.2.5: Pin 9 o22f COM8 Function Selection (J3).....	30
4.3	COM Port Interface.....	30
	Table 4.7: Serial Port Function.....	30
	Table 4.7: Serial Port Settings.....	30

Chapter 5 Pin Assignments31

5.1	Front Side connectors.....	32
5.2	Rear Side Connectors.....	32
5.3	Power Connector (12/ 24V; 6 ~ 36V).....	32
	Table 5.3: Power connector.....	32
5.4	Smart Display Connector.....	33
	Table 5.4: Smart display connector.....	33
5.5	RS-232 Connector (COM3, COM8).....	34
	Table 5.5: RS232/485/J1708 connector.....	34
5.6	RS-232 (COM9) / RS-485 (COM5) / J1708 (COM6) Connector.....	34
	Table 5.6: RS232/485/J1708 connector.....	34
5.7	DI / DO Connector.....	35
	Table 5.7: DI/DO connector.....	35
5.8	CAN/Video in Connector.....	35
	Table 5.8: CAN/Video in connector.....	35
5.9	LED Connector.....	36
	Table 5.9: LED connector.....	36

Chapter 6 SW demo utility set Up.....37

6.1	Introduction.....	38
-----	-------------------	----

6.1.1	Execute J1939 demo utility.....	38
	Figure 6. 1 IMC demo utility.....	38
	Figure 6.2 J1939 truck simulator.....	38
	Figure 6.3 J1939 test	39
	Figure 6.4 J1939 test	39
6.1.2	CAN Test.....	39
	Figure 6. 9 CAN test -2	39
6.2	RTC test.....	40
	Figure 6.10 RTC test -1.....	40
	Figure 6.11 RTC test -2.....	40
	Figure 6. 12 RTC test-3.....	40
	Figure 6. 13 RTC test-4.....	40
	Figure 6.14 RTC test-5.....	41
6.3	Power Management	41
6.3.1	Power management Mechanism.....	42
6.3.2	Power Management utility program.....	43
6.3.3	Power Management Parameter settings.....	43
	Figure 6.15 Power management test utility.....	43
6.3.4	TREK-550 power consumption.....	43
6.4	GPIO Test.....	44
	Figure 6.16 DI/O test	44
	Figure 6.17 Digital in.....	44
	Figure 6.18 Digital out.....	45
6.5	Video in Test.....	45
	Figure 6.19 Video test utility.....	45
6.6	Dead reckoning.....	45
6.7	G- sensor	46

Appendix A Paired with TREK-30347

A.1	Table A.1: TREK-303 spec	48
A.2	Table A.2 Smart Display connector pin out.....	49
	Figure A.1 Hotkey utility.....	51

Chapter 1

General Information

This chapter gives background information on the TREK-550 In-Vehicle Computing Box.

Sections include:

- Introduction
- General Specifications
- Dimensions

1.1 Introduction

The TREK-550 is a dedicated box computer for industrial vehicle fleets, transport trucks, buses and taxis. TREK-550 combined with variety of I/O connectors can be connected to devices like OBD-II or TPMS (Tire Pressure Monitoring System). Dual display/dual audio interfaces supporting different resolutions can deliver different applications to different displays; eg: one application to a fleet driver and another to a digital signage application.

Built-in wireless communications (WWAN) enable TREK-550 to send important driver/vehicle/location/cargo information back to the control center. TREK-550 can also operate in extreme environments with features like a wide working temperature range (-30 to 70 degrees). TREK-550 also uses a special design to handle the critical issue of in-vehicle power. Special power protection (ISO7637-2/SAE J1455 Class A/ SAE J1113) and car power management software (Ignition on/off, delay on/off, low battery monitor) prevent electrical noise and surges from impacting the system, guarding against damage from transient car power. TREK-550 also support rear view monitor through connecting video in port. With this feature, driver can real time monitor the environment on two sides of the truck for driving safety. TREK-550 can also support dead-reckoning feature, which means the truck can still be traced even the driver is driving in a tunnel.

I/O Connectors

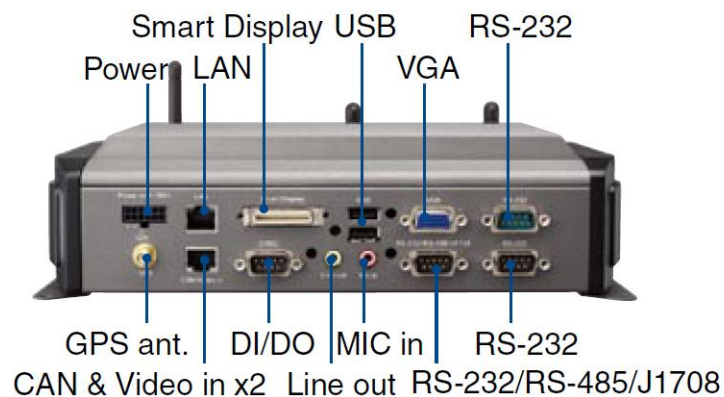
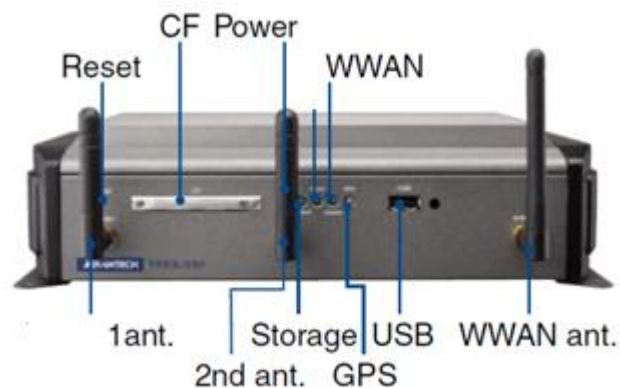

1.2 General Specifications

Key features

- Supports Win CE 6.0, XPE, XP and Linux
- Automotive grade working temperature range (-30° C to 70° C)
- Rich I/O including CAN, LAN, RS-232, RS-485, J1708, isolation 4DI/4DO, Line out, Mic in, USB, and Video-in
- Built-in communication modules, including GSM/GPRS/HSDPA/CDMA
- GPS with AGPS and dead reckoning technology (Gyro & speed line)
- Certifications: CE/FCC/e-mark, MIL-SD810F, ISO 7637-2, SAE J1455, SAE J1113 regulations
- Dual display/audio output for both driver and passenger
- Ignition on/off delay; SW controllable for car power management

Specifications

- **Dimensions:** (W x H x D): 271 x 149 x 69.7 mm.
- **Weight:** 4 kg.
- **Vehicle power feature:**
 - **Input voltage:** 6 ~ 36Vdc, support ignition cold crank
 - **Support Ignition on/off**
 - **Support low battery shut-down protection threshold (optional)**
 - **Support power off event delay**
 - **Support power on delay**
 - **Support power low delay**
 - **Support power low hard delay**
 - **Support hard off delay**

Note! For more detail of function please refer to Chapter 6, Section 6.3 of this manual.



- **Enclosure:** Ruggedized aluminum without ventilation holes.
- **CPU:** Intel Atom Z510PT 1.1Ghz/ Z520PT 1.33Ghz
- **Chipset:** Integrated in LE82US15EE
- **BIOS:** 4MB Flash BIOS, ACPI Compliant.
- **System memory:** One 200-pin SODIMM sockets, accepts up to 2 GB DDR2 667 SDRAM
- **Storage:**
 - **CF:** Supports one 50-pin socket for Compact-Flash type I/II (True PATA mode).
 - **SSD/HDD (SATA)** (optional)
- **Serial ports:** Two RS-232, 5V@500mA, 12V@ 250mA, ping9, by jumper selected. One 4-wire RS232, 1 x RS485, 1 x J1708 ports.
- **Universal serial bus (USB) port:** Supports up to three USB2.0. One from smart display port.
- **LAN port:** 1 x 10/100/1000 Ethernet (with LEDs) by RJ45.

Note! This product is covered by one or more of the following patents:
US5,307,459, US5,434,872, US5,732,094, US6,570,884, US6,115,776 and US6,327,625.



- **Video output:** 1 x VGA output by DB-15 (independent display).
- **Video in:** 2 x composite video input selection supported format (for rear view monitor) by RJ-45 connector
- **Mini PCI express bus expansion slot:** Accepts full size mini PCI bus card.

- **Watchdog timer:** Supports 0-255 secs time intervals, SW programmable and SW enable/disabled.
- **RTC Battery:** 3.0 V @ 200 mAH lithium battery.
- **Power management:** Supports power saving modes including Normal/suspend-to-disk modes.
- **Digital I/O:** Isolated 4 digital input and 4 digital output
- **CAN bus:** Support CAN V2.0B up to 500 kb/s.
- **Audio:**
2 audio codecs, one is for smart display, one is for TREK-550 line out and mic in phone jack.
- **Optional modules:**
 - ◆ **GPS**
 - LEA-5S: 50 channels GPS
 - LEA-4R: 16 channels dead reckoning GPS
 - ◆ **RF:**
 - Quad-band GSM/GPRS, HSDPA, CDMA
- **PCI Express Bus Ethernet Interface: Ethernet: support 1000/100/10Base-T auto-sensing capability.**
- **Operating temperature:** -30 ~ 70° C
- **Relative humidity:** 10 ~ 95% @ 40° C (non-condensing)
- **Shock:** 30 G peak acceleration (11 msec duration)
- **Certifications:** CE, FCC, CCC, Emark
- **Vibration:** 5 ~ 500 Hz SAE J1455 4.9.4.2, MIL-STD-810F 514.5

1.3 Dimensions

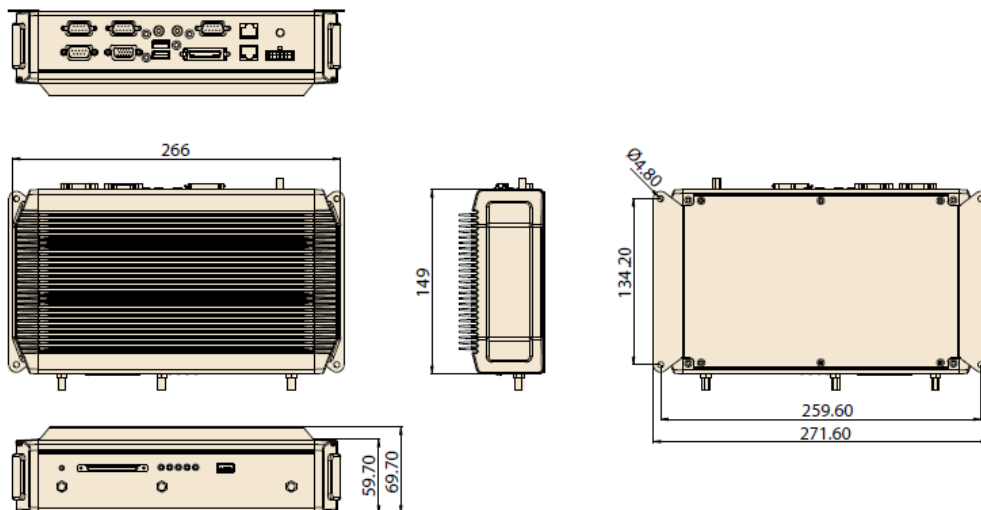

Figure 1.1 TREK-550 dimensions

Chapter 2

System Setup

This chapter details system setup on TREK-550.

Sections include:

- A Quick Tour of the computer box
- Installation Procedures
- Running the BIOS Setup Program

2.1 A Quick Tour of the TREK-550 Computing box.

Before starting to set up the In-Vehicle Computing Box, take a moment to become familiar with the locations and purposes of the controls, drives, connectors and ports, which are illustrated in the figures below. When the Computer box is placed inside truck glove cabinet or under the passenger's seat next to the driver, its front appears as shown in Figure 2.1.

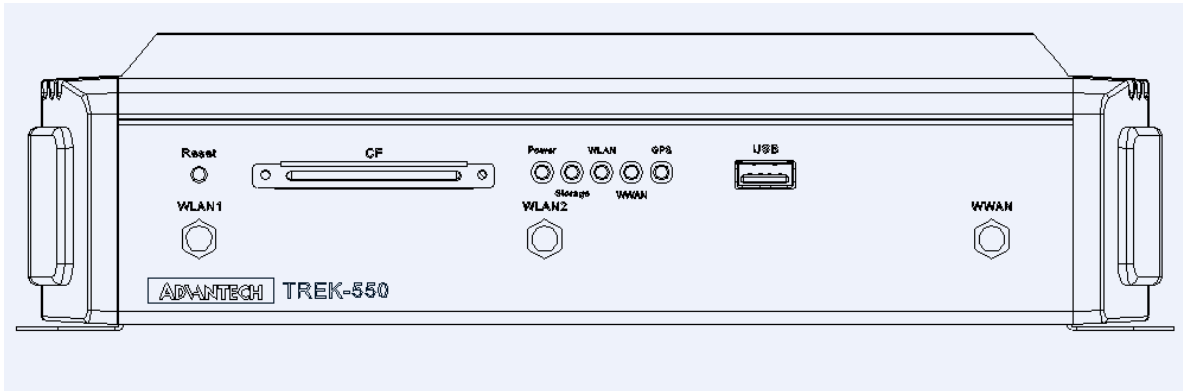

Figure 2.1. Front view of TREK-550

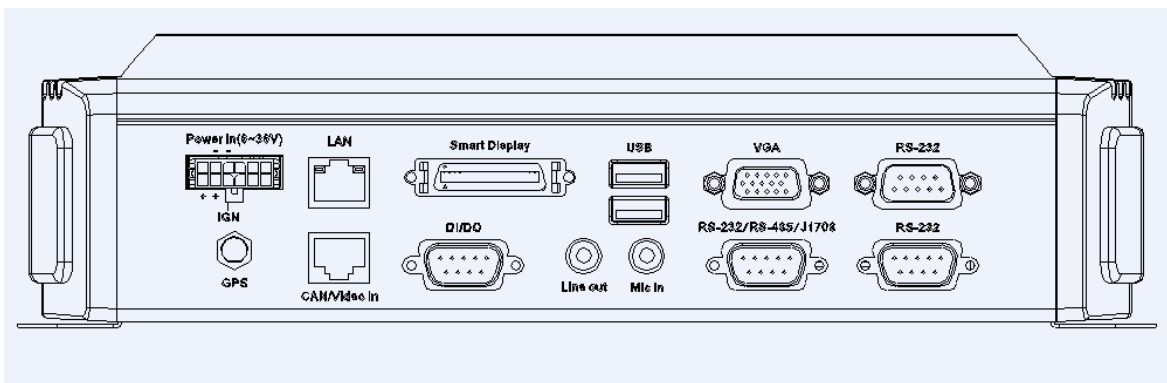
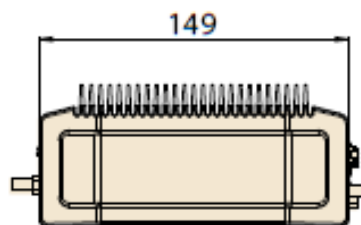
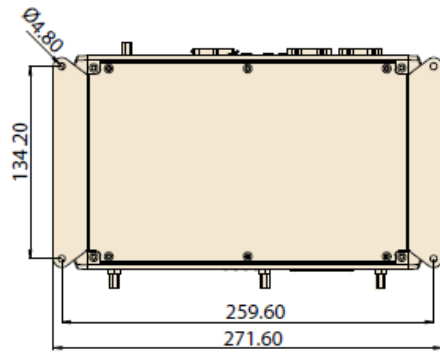

Figure 2.2. Rear view of TREK-550



Unit: mm

Figure 2.3. Side view of TREK-550



Unit: mm

Figure 2.4. Bottom view of TREK-550

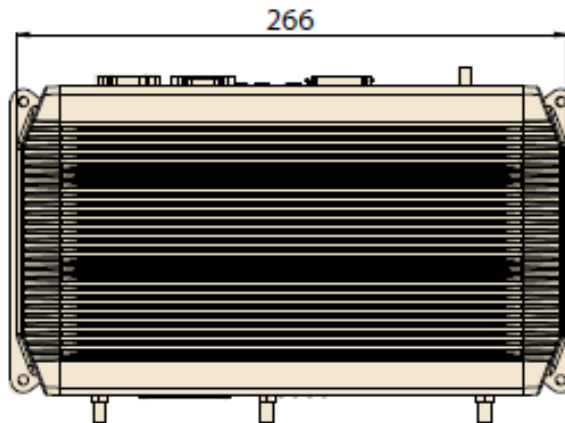

Unit: mm

Figure 2.5. Top view of TREK-550

2.2 Installation Procedures

2.2.1 Connecting the Power Cord

Connect the three pin waterproof power cord to the DC inlet of the In-Vehicle Computing Box. On the open-wire end, one pin is reserved for positive voltage and is marked, "+"; one pin is reserved for ground and is marked, "-"; and, one pin is reserved for the ignition signal with an "ignition" mark.

Note! *Ignition on/off setting: The TREK-550 supports an ignition on/off function so that you can power on/off the TREK-550 via the ignition signal/voltage and connect the TREK-550 vehicle ignition switch.*

Table 2.2.1 Pin Definition of Power Cord

Pin	Definition	Color
1	+	Red
3	-	Black
4	Ignition	Orange

2.2.2 Power Connector

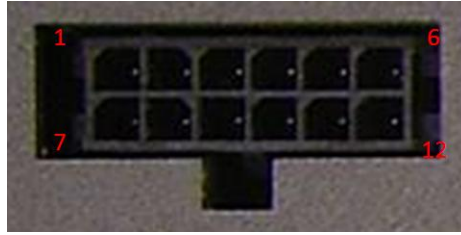

Figure 2.6. Power connector outlook

Table 2.2.2 Pin definition of PowerConnector(Molex Manufacturer part no.0430451200)			
Pin	Signal	Pin	Signal
1	Chassis Ground	2	Ground
3	Ground	4	(Reserved)
5	(Reserved)	6	(Reserved)
7	Power Input (6~36 VDC)	8	Power Input (6~36 VDC)
9	Acc Ignition Input	10	Ground
11	(Reserved)	12	Power button Input

Connector : Molex 430451200

Mating connector: Molex 0430251200



Figure 2.7. Power connector photo

Note! Fuse holder: The fuse holder on the power cable is water/dust proof; you may change the fuse (5 Amp) easily by yourself.

2.3 Running the BIOS Setup Program

In most cases, the computer will have been properly set up and configured by the dealer or SI prior to delivery. However, it may still be necessary to adjust some of the computer's BIOS (Basic Input-Output System) setup programs to change the system configuration data, like the current date and time, or the specific type of hard drive currently installed.

The setup program is stored in read-only memory (ROM). It can be accessed either when turning on or resetting the computer, by pressing the "Del" key on the keyboard immediately after powering up the computer.

The settings that are specified with the setup program are recorded in a special area of the memory called CMOS RAM. This memory is backed up by a battery so that it will not be erased when turning off or resetting the system. Whenever the power is turned on, the system reads the settings stored in CMOS RAM and compares them to the equipment check conducted during the "power on self-test" (POST). If an error occurs, an error message is displayed on screen, and the user is prompted to run the setup program.

2.4 Installing the Drivers for Win XP

After installing system software, the computer is ready to set up the AMD chipset, VGA, audio, LAN, and touch screen functions. All the pre-requisite drivers are stored on a CD-ROM disc entitled "Drivers and Utilities" (Check the correct wording on the CD, which can be found in the accessory box.)

The utility directory includes multimedia programs. Some drivers and utilities in the CD-ROM disc have their own text files which help users install the drivers and understand their functions.

These files are a very useful supplement to the information in this manual. For more updated driver please refers to Advantech website, www.advantech.com/support

The drivers for TREK-550 are listed as below, please just execute the drivers for installation

Device	Version
Intel SCH INF Update	8.8.0.1011
Intel US15 GMA500 Graphic Driver	6.14.11.1018
PenMount Universal Driver	2.1.0.263
Realtek RTL8111C 10/100/1000 PCI-E NIC	5.698.701.2008
Realtek ALC888 High Definition Audio	5.10.0.5804
FTDI FT4232 BUS USB Driver	2.6.0.0
ublox LEA-5S/4R Driver	1.2.0.5
Sierra Wireless MC5728V	Watcher 7.11
Sierra Wireless MC8790V	3GWatcher Build2258
Ralink RT3091 Wireless LAN Card (AW-NE768)	1.4.2.1
BT-203 Utility BlueSoleil (Optional)	2.1.3.0
TREK-550 Command Line Utility	2010-04-14 Ver 1.0
Disable standby registry	-

Note! *The drivers and utilities used for the TREK-550 are subject to change without notice. If you are in doubt, check Advantech's website or contact our application engineers for the latest information regarding drivers and utilities.*

Chapter

3

Hardware & Peripheral Installation

This chapter details the installation of hardware for TREK-550.

Sections include:

- Overview of Hardware Installation and Upgrading
- Installing the Storage Device and Memory
- Installing Optional Accessories
- Fuse

3.1 Overview of Hardware Installation & Upgrading

The In-Vehicle Computing Box consists of a PC-based computer that is housed in a ruggedized aluminum enclosure. Any maintenance or hardware upgrades can be completed after removing the bottom cover plate.

Warning! Do not remove the ruggedized aluminum covers until verifying that no power is flowing within the computer. Power must be switched off and the power cord must be unplugged. Take care in order to avoid injury or damage to the equipment.



3.2 Installing the Storage Device and Memory

The In-Vehicle Computing Box can only use a Compact Flash Card (CFC) as a storage device. Put the CFC into the CF slot and insert the RAM into the 200-pin SODIMM socket on the main board.

3.3 Installing Optional Accessories

Optional accessories, like RAM mount kits or other functional modules are available for purchase to complement TREK-550. The following are instructions for accessory installation.

3.3.1 Installing TREK-550 peripheral modules

There are 6 screws on the bottom of TREK-550, if you want to install the peripherals in TREK-550, please use M2 type screw to open the system.

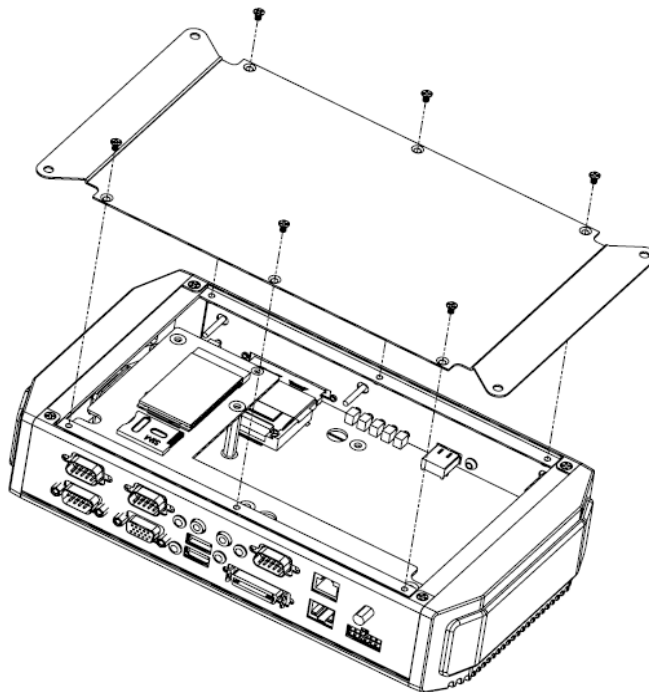

Figure 3.1 Install peripheral in the system

3.3.2 Installing the MiniPCI type WWAN, SIM card and coin battery

The WWAN module is on the Mini PCI slot can be easily installed, just unlock the 6 screws from the bottom cover, you may easily install it, so as SIM card.

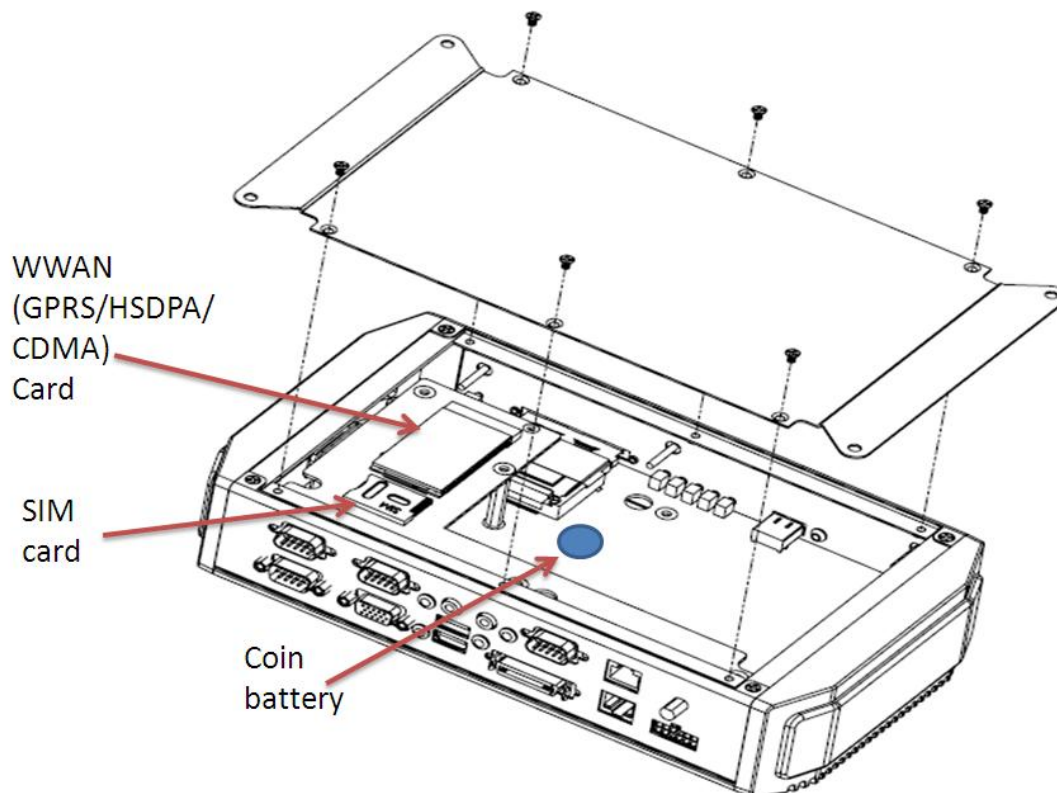

Figure 3.2 Mini PCI type WWAN module, SIM card and coin battery from bottom view

3.3.4 Installing CF card

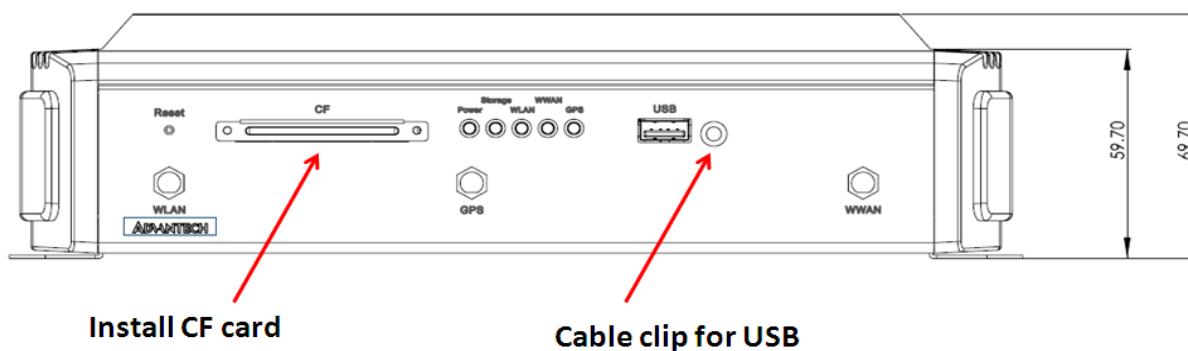

Figure 3.4 Installing CF card

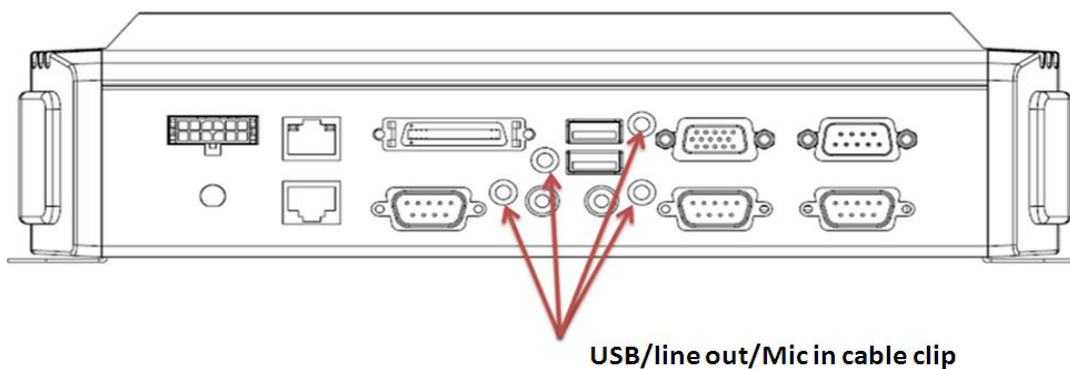

Figure 3.5 Install cable clip

3.3.5 GPS module is unable to be installed by customer.

GPS module is not allowed customer to install.

3.4 Paired with TREK-303 Specifications

See Appendix A

TREK-550 provides both VGA function and LCD to connect with TREK-303, it can be send out by different content, clone to VGA output.

Chapter 4

Jumper Settings and Connectors

This chapter explains how to set up the In-Vehicle Computing Box hardware, including instructions on setting jumpers and connecting peripherals, and how to set switches and read indicators.

Be sure to read all the safety precautions before beginning the installation procedure.

Sections include:

Jumpers Setting

4.1 Setting Jumpers and Switches

It is possible to configure the In-Vehicle Computing Box to match the needs of the application by resetting the jumpers. A jumper is the simplest kind of electrical switch. It consists of two metal pins and a small metal clip, often protected by a plastic cover that slides over the pins to connect them. To “close” a jumper, connect the pins with the clip. To “open” a jumper, remove the clip. Sometimes a jumper has three pins, labeled 1, 2, and 3. In this case, connect either pins 1 and 2, or pins 2 and 3.

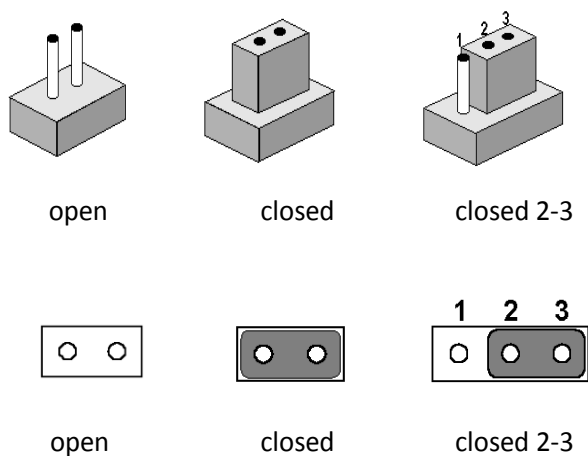

A pair of needle-nose pliers may be helpful when working with jumpers. If there are any doubts about the best hardware configuration for the application, contact the local distributor or sales representative before making any changes.

An arrow is used on the motherboard to indicate the first pin of each jumper.

4.1.1 Locations of the Jumpers and Connector

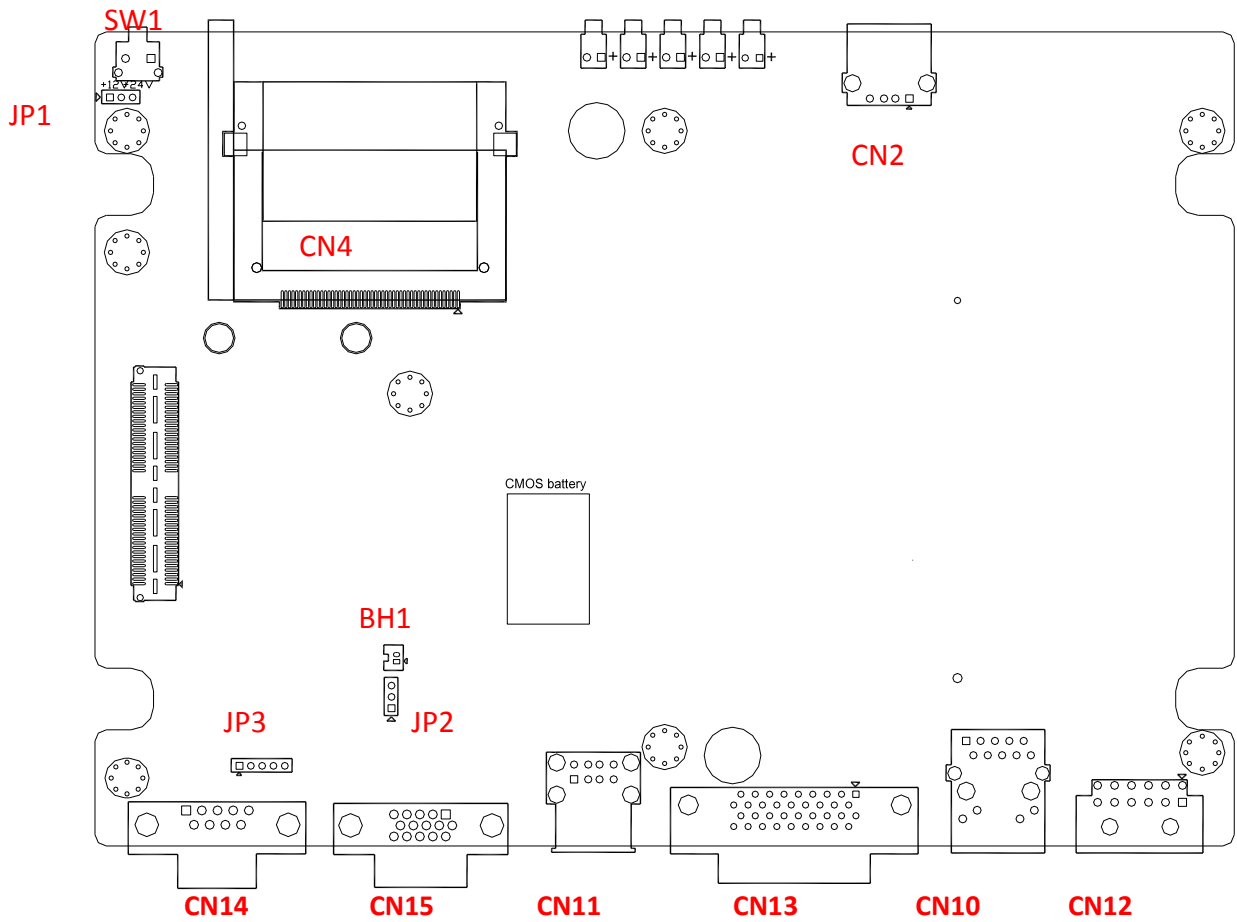

Figure 4.1 Locations of jumpers and connectors on top side the motherboard.

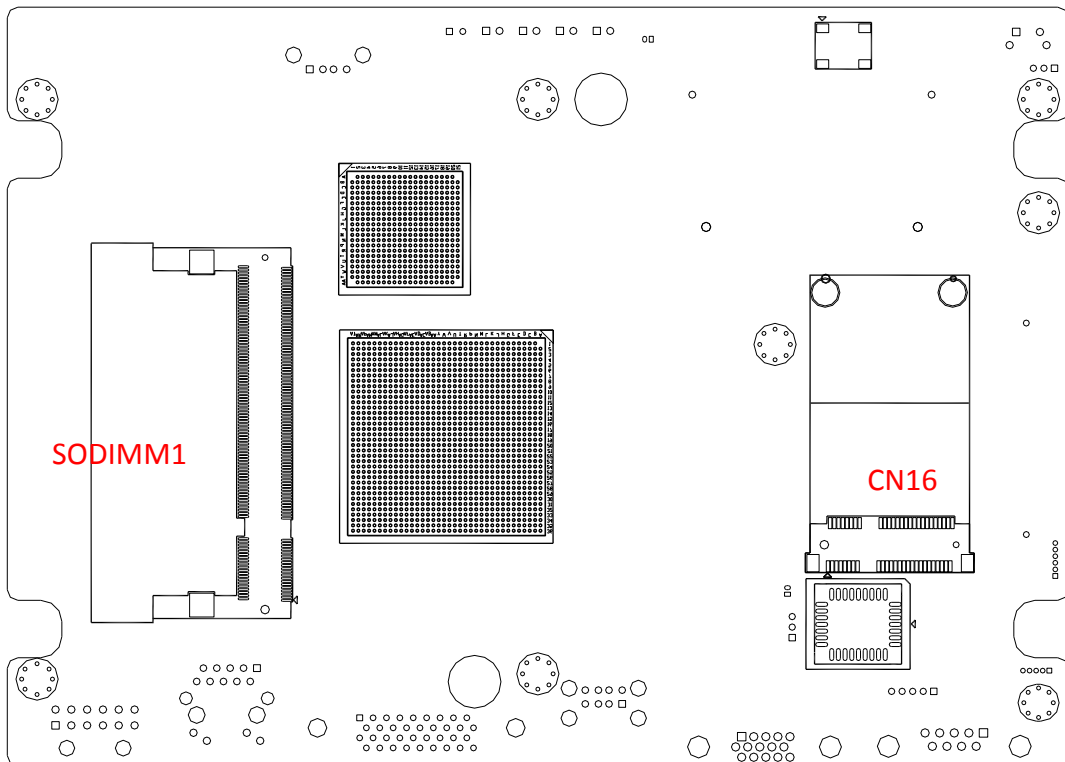

Figure 4.2 Locations of jumpers and connectors on bottom side of the motherboard

The figures below show the locations of the jumpers and connectors on daughter board used in TREK-550.

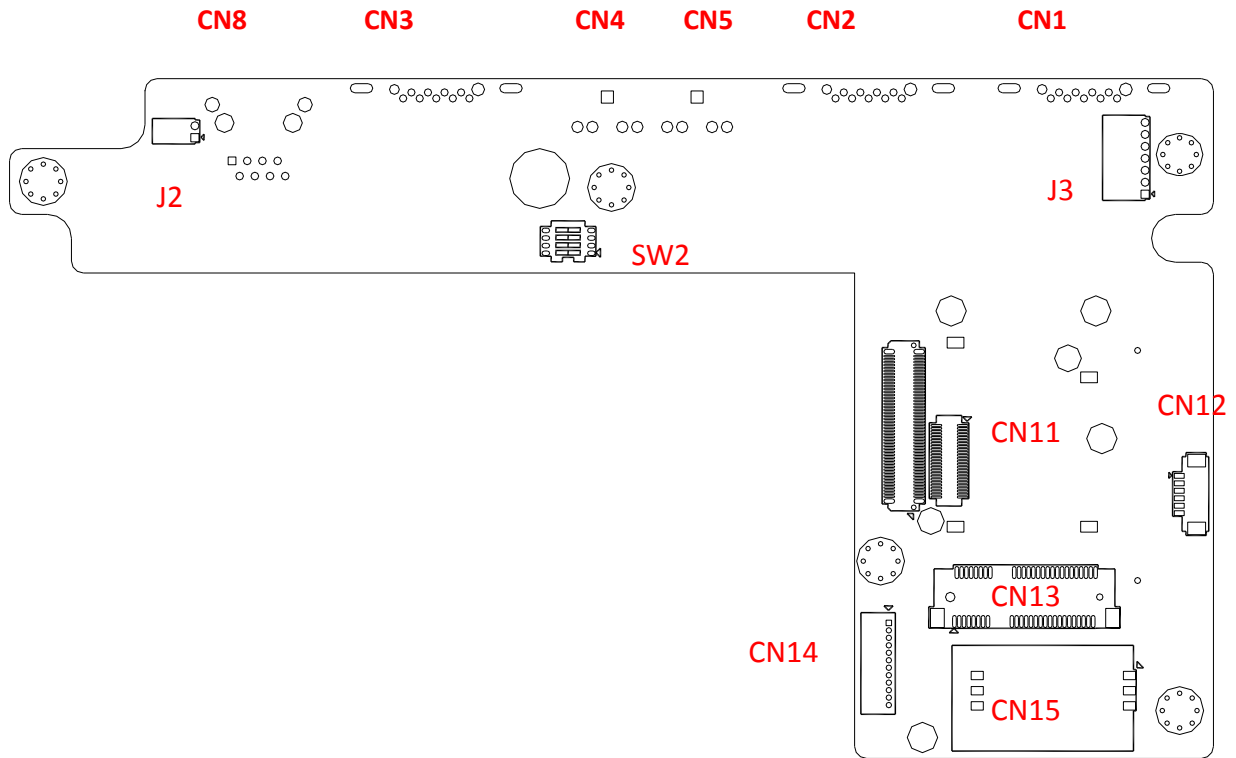

Figure 4.3 Locations of jumpers and connectors on bottom side of the daughter board.

4.1.2 Jumpers

Table 4.1.2.1: Jumpers on motherboard

Location	Function
JP1	Vehicle input voltage selection
JP2	CMOS clear for external RTC
JP3	Pin9 of COM3 function selection

Table 4.1.2.2: Jumpers on daughter board

Location	Function
J2	CAN bus termination selection
J3	Pin9 of COM8 function selection
SW2	DI/GPS Function selection

4.1.3 Connectors

On-board connectors link the In-Vehicle Computing Box to external devices such as hard disk drives. The table below lists the function of each connector.

Table 4.1.3.1: Connectors on motherboard

Location	Function
SW1	RESET
CN2	USB connector
CN4	CF connector
CN10	LAN connector
CN11	USB connector
CN12	Power input connector
CN13	Smart Display Connector
CN14	RS-232 connector (COM3)
CN15	VGA connector
CN16	Mini-PCIe Socket (USB + PCIe interface) Mini card (standard interface)
BH1	RTC battery
SODIMM1	SODIMM connector for DDR2 SDRAM

Table 4.1.3.2: Connectors on daughter board

Label	Function
CN1	RS-232 connector
CN2	4-wire RS-232 + RS-485 + RS-1708 connector
CN3	Isolated Digital I/O connector
CN4	Line-Out phone jack
CN5	Mic-In phone jack
CN8	Video-In and CAN bus connector
CN11	WWAN module connector
CN12	Bluetooth module connector
CN13	Mini-PCIe Socket (USB interface, for WWAN module) Mini card (USB interface)
CN14	GPS module connector
CN15	SIM holder

4.2 Jumper Settings

4.2.1 CMOS Clear for External RTC (JP2)

- Warning!**
1. To avoid damaging the computer, always turn off the power supply before setting "Clear CMOS."
 2. Set the jumper back to "Normal Operation" before turning on the power supply!



Table 4.2.1: Clear CMOS / External RTC (JP1)

Normal Operation (Default)	Clear CMOS

4.2.2 Power Input Voltage Setting (JP1)

TREK-550 must be configured properly according the vehicle power input range.

Table 4.4.2: Power Input Voltage Selection (JP1)

12V Input (Default)	24V Input

4.2.3 Pin 9 of COM3 Function Selection (JP3)

Pin 9 on COM3 port can be configured as RI, 5V or 12V output.

Table 4.2.3: Pin 9 of COM3 Function Selection (JP3)

RI	+5VDC (max. 500mA)	+12VDC (max. 250mA)

4.2.4 Pin 9 of COM8 Function Selection (J3)

Pin 9 on COM8 port can be configured as RI, 5V or 12V output.

Table 4.2.4: Pin 9 of COM8 Function Selection (J3)

RI	+5VDC (max. 500mA)	+12VDC (max. 250mA)

4.2.5 DI/GPS Function Selection (SW2)

If the GPS module with Dead Reckoning function is used, the digital inputs 3/4 will be used as inputs of GPS module. DIP switch (SW2) is used to select the function on DI 3/4 (Digital Input 3/4).

Table 4.2.5: Pin 9 of COM8 Function Selection (J3)

	Digital Input	GPS (for Dead-Reckoning)
SW2.1	OFF	ON
SW2.2	ON	OFF
SW2.3	OFF	ON
SW2.4	ON	OFF

4.3 COM Port Interface

The computer provides totally ten serial ports for difference uses. Six of ten serial ports (COM1~COM6) are implemented with Super I/O chip and their physical address are fixed. And the other four serial ports are done by a USB serial converter, and need driver support to work. In Advantech provided WES (Windows Embedded Standard), WinXPe and Win CE 6.0 OS, the four USB-to-Serial serial ports are fixed from COM8 to COM11).

Table 4.3.1: Serial Port Function

Port	Function
COM1	2-wire RS-232 (TXD/RXD) for TREK-303
COM2	3-wire RS-232 (TXD/RXD/RTS) for Touch on TREK-303
COM3	Full functional RS-232
COM4	For power management control
COM5	RS-485
COM6	J1708
COM8	Full functional RS-232
COM9	4-wire RS-232 (TXD/RXD/RTS/CTS)
COM10	For WWAN module
COM11	For WWAN module

Table 4.3.2: Serial Port Settings

Port	Address Range	Interrupt
COM1	3F8 ~ 3FF	4
COM2	2F8 ~ 2FF	3
COM3	2E8 ~ 2EF	5
COM4	2D8 ~ 2DF	7
COM5	2E0 ~ 2E7	10
COM6	2D0 ~ 2D7	11

Chapter 5

Pin Assignments

This chapter explains pin assignments on the TREK-550.

Sections include:

- Front/side Connector
- Power connector
- Smart display connector
- RS232 Connectors
- DI/DO connectors

5.1 Front Side Connectors

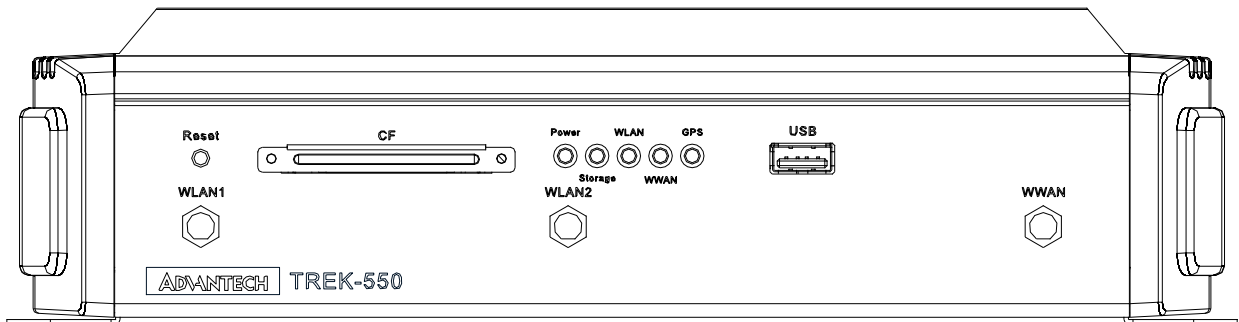

5.2 Rear Side Connectors

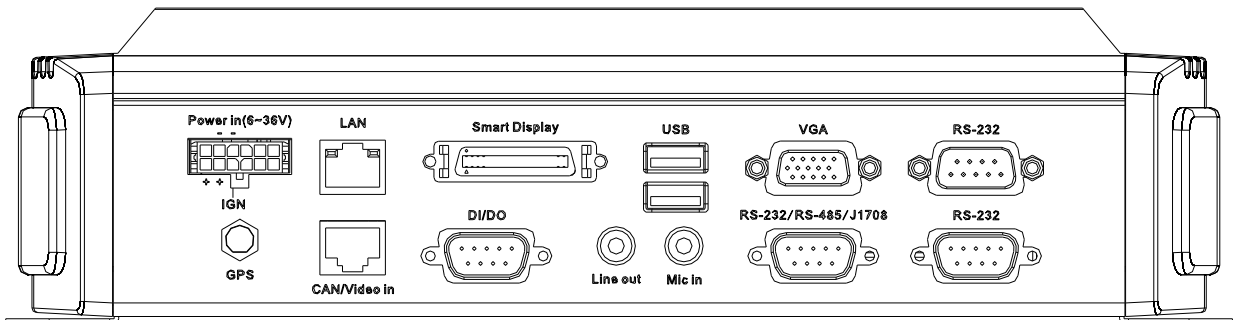

5.3 Power Connector (12/ 24V; 6 ~ 36V)

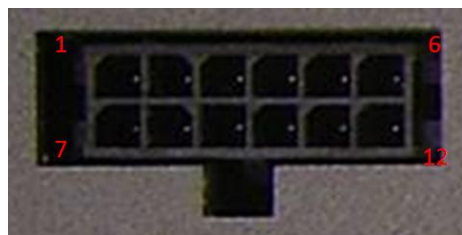

Molex Manufacturer part no. 0430451200

Table 5.3: Power Connector

Pin	Signal	Pin	Signal
1	Chassis Ground	2	Ground
3	Ground	4	(Reserved)
5	(Reserved)	6	(Reserved)
7	Power Input (6~36 VDC)	8	Power Input (6~36 VDC)
9	Acc Ignition Input	10	Ground
11	(Reserved)	12	Power Button Input

5.4 Smart Display Connector

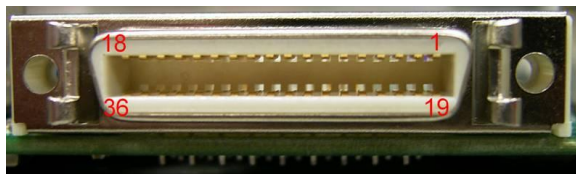

Table 5.4: Smart Display Connector

Pin	Signal	Pin	Signal
1	Backlight Enable output #	2	Panel Power Enable output #
3	LVDS Ground	4	Reset Button Input #
5	LVDS Clock +	6	LVDS Clock -
7	LVDS Ground	8	LVDS Ground
9	LVDS Data2 +	10	LVDS Data2 -
11	RS232 TXD1 #	12	RS232 RXD1 #
13	LVDS Data1 +	14	LVDS Data1 -
15	LVDS Ground	16	LVDS Ground
17	LVDS Data0 +	18	LVDS Data0 -
19	USB D-	20	USB D+
21	USB Ground	22	USB Ground
23	+12VDC output (+/- 5%, max 1A)	24	+12VDC output (+/- 5%, max 1A)
25	+12VDC output (+/- 5%, max 1A)	26	+12VDC output (+/- 5%, max 1A)
27	Power Ground	28	Power Ground
29	Power Ground	30	Power Ground
31	RS232 TXD2 #	32	RS232 RXD2 #
33	RS232 RTS2	34	Power Button Input #
35	Audio Ground	36	Mono. Line-out

5.5 RS-232 Connector (COM3, COM8)

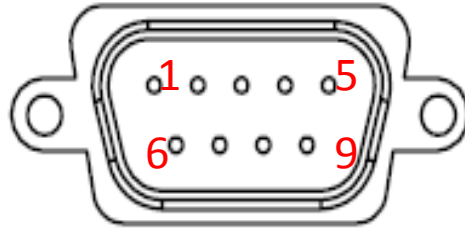

Table 5.5: RS-232 / RS-485 / J1708 Connector

Pin	Signal	Pin	Signal
1	RS-232 DCD	2	RS-232 RXD
3	RS-232 TXD	4	RS-232 DTR
5	RS-232 Ground	6	RS-232 DSR
7	RS-232 RTS	8	RS-232 CTS
9	RS-232 RI / +5V(max. 500mA) / +V12 (max. 250mA)		

5.6 RS-232 (COM9) / RS-485 (COM5) / J1708 (COM6) Connector

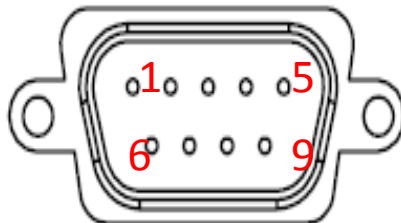

Table 5.6: RS-232 / RS-485 / J1708 Connector

Pin	Signal	Pin	Signal
1	RS-232 RTS	2	RS-232 RXD#
3	RS-232 TXD	4	RS-232 CTS
5	Ground	6	RS-485 D-
7	RS-485 D+	8	J1708 D-
9	J1708 D+		

5.7 DI / DO Connector

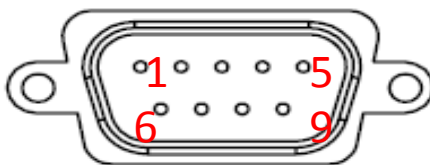

Table 5.7: DI / DO Connector

Pin	Signal	Pin	Signal
1	Isolated Dry Contact Input 1	2	Isolated Dry Contact Input 2
3	Isolated Dry Contact Input 3 /Speed signal input for DR*	4	Isolated Dry Contact Input 4 /Forward signal input for DR*
5	Isolation Ground	6	Isolated Relay Driver Output 1
7	Isolated Relay Driver Output 2	8	Isolated Relay Driver Output 3
9	Isolated Relay Driver Output 4		

*Note. Regarding the setting of Pin3/4, please refer paragraph 4.2.5 (DI/GPS Function Selection).

5.8 CAN / Video-In Connector

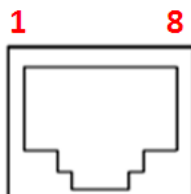

Table 5.8: CAN / Video-In Connector

Pin	Signal	Pin	Signal
1	CAN_H	2	CAN_L
3	CAN_SHIELD	4	CAN_SHIELD
5	Video In 2	6	Video Ground
7	Video In 1	8	Video Ground

5.9 LED indicator

System power indicator	This system power indicator is a red LED, controlled by hardware. When the system is in NORMAL mode, this LED will be lit on. In other modes, this LED will be lit off.
GPS activity indicator	This GPS activity indicator, a blue LED, is used to show the GPS activity. This LED is controlled directly by GPS chips.
WLAN activity indicator	This WLAN activity indicator, a green LED, is used to show the activity of installed WLAN module. This LED is controlled directly by WLAN module.
WWAN activity indicator	This WWAN activity indicator, a green LED, is used to show the activity of installed WWAN module. This LED is controlled directly by WWAN module.
User-defined indicator	This user-defined indicator, a green LED, is used for customization. This LED is controlled by Software.

**Red
(power)**

**Green
(Storage
access)**

**Green (RF
data transfer)**

**Green
(RF link)**

**Blue (GPS
operation)**



Chapter 6

Software demo utility setup

This appendix explains the software demo utility for TREK-550.

Sections include:

- Introduction
- How to set up demo utility

6.1 Introduction

To make the hardware easier to access for programmers, Advantech has developed a demo utility in order to let customer test the functions on TREK-550. This document describes detailed information for each Advantech demo utility so that application developers can become more familiar with using them.

For technical support, contact Advantech application engineers worldwide. For news updates, visit our website: www.advantech.com

6.1.1 Execute J1939 demo utility

This section explains how to install the Advantech demo utility in Windows XP Pro / Embedded.

1. Execute the test program called "IMC_Demo"

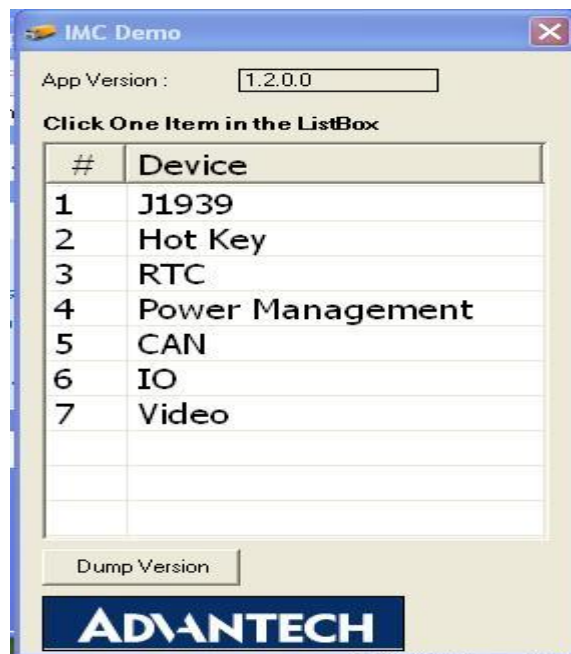

Figure 6. 1 IMC demo utility

2. Click J1939: customer may connect directly to the truck; we use a car simulator board below to explain how J1939 protocol can be executed. First, connect to the simulator board to TREK-550 CAN port and console PC, once the simulator is powered on (connect to the truck), you can start getting the data, just click [Read], you may get the data you need from the car simulator, click [Read], you may transfer the data to Console

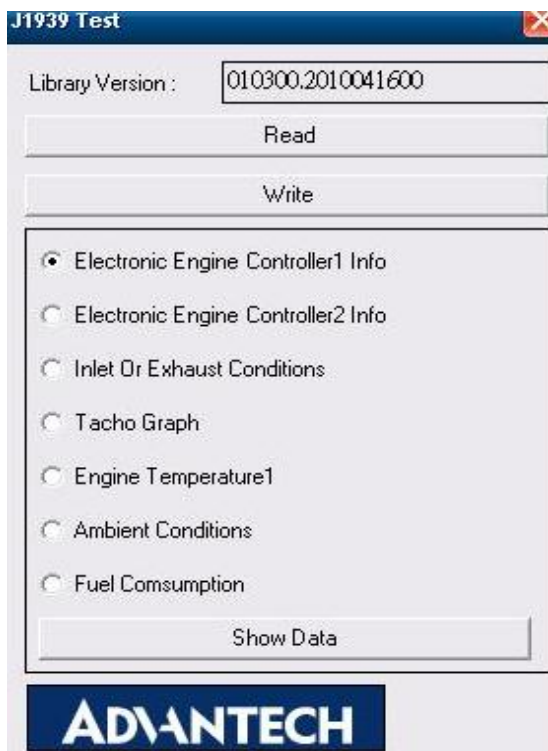

Figure 6.3 J1939 test -1

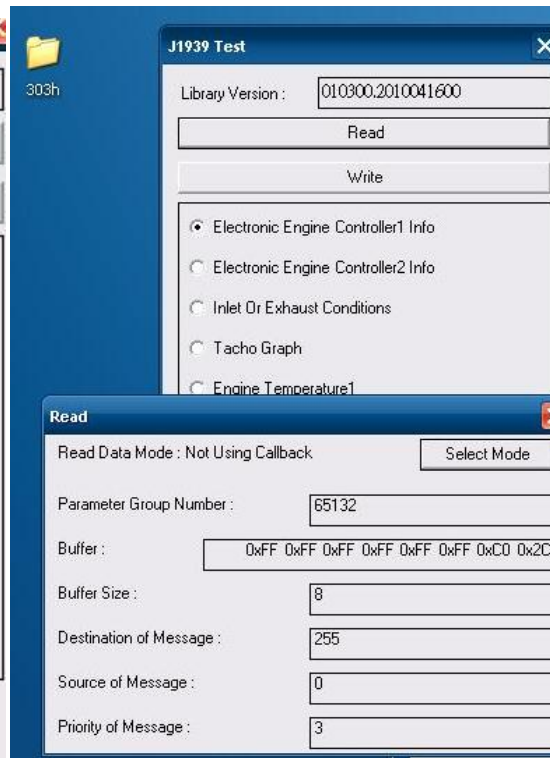

Figure 6.4 J1939 test -2

6.1.2 Execute CAN demo utility

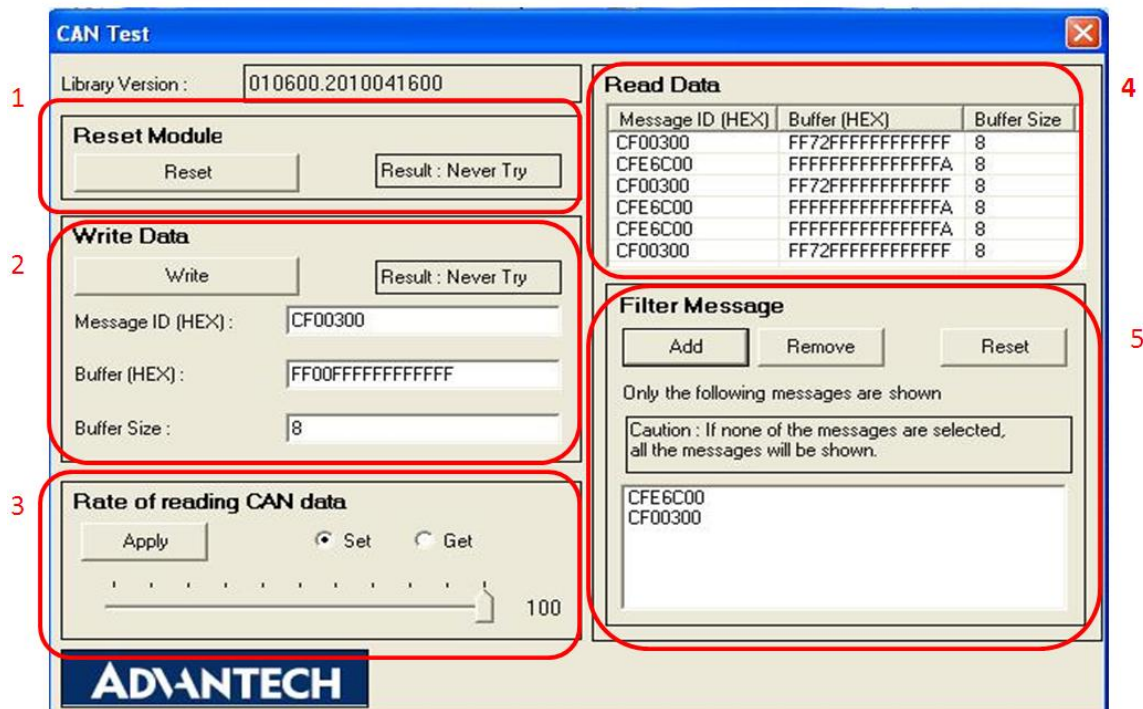

Figure 6. 9 CAN test

1. Reset the module
2. Transmit CAN message
3. Set the polling rate of CAN message reception
4. Received CAN message.
5. Set up the filter of CAN message (only show the message ID)

6.2 RTC test

Execute "RTC test"

1. **For RTC Time setting:** You may set year, month, date, and time show as below.

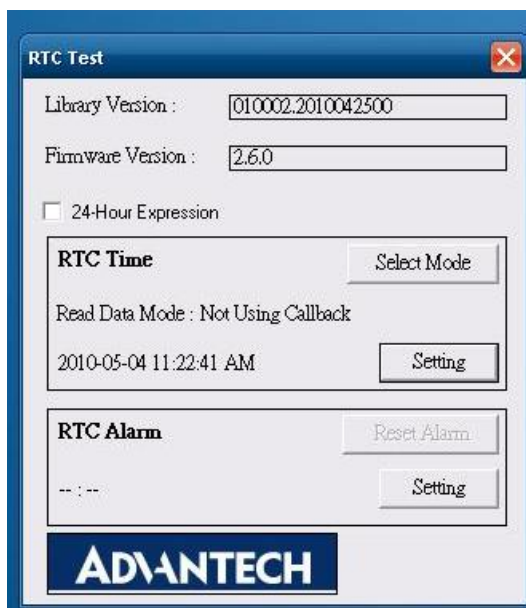

Figure 6.10 RTC test -1



Figure 6.11 RTC test -2

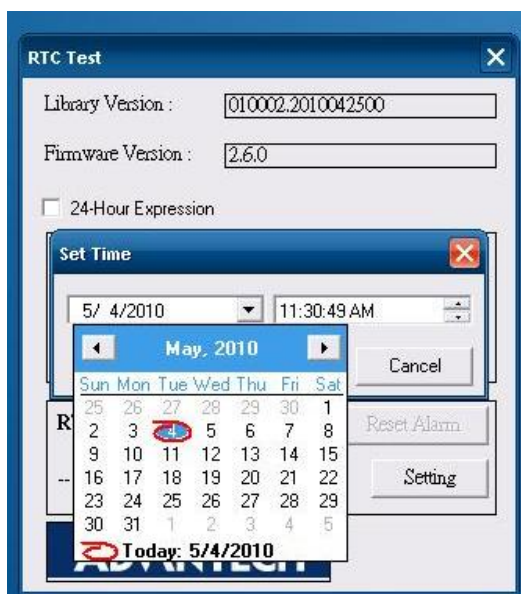

Figure 6. 12 RTC test -3



Figure 6. 13 RTC test -4

2. **RTC Alarm Setting:** You may also set Alarm time; you may wake up the system by the time you have set. Please refer to below figure 6.

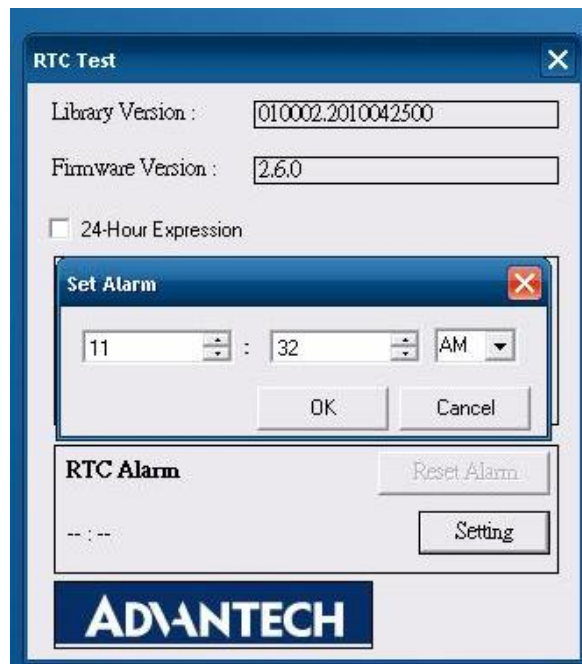

Figure 6.14 RTC test -5

6.3 Vehicle Power Management

6.3.1 Power management Mechanism

The feature of Vehicle Power Management (VPM) is provided for users to fulfill the special requirements on in-vehicle applications.

- **Ignition on/off**

- **Turn on the system by ignition**

For the cases of in-vehicle applications, ignition signal is often used to turn on or shutdown system. When the system is in OFF state and ignition is turn ON, the VPM controller will countdown ON_DELAY; once it counts to zero, the system will be turn on.

- **Shutdown the system by ignition**

When the system is powered on and ignition is turn off, the OFF_EVENT_DELAY will start to count down. During this stage, if the ignition is back to ON, VPM controller will stop countdown and reset the OFF_EVENT_DELAY value. If OFF_EVENT_DELAY is keeping counting to zero, VPM controller will send a event (power button press) to the system and start to count HARD_OFF_DELAY. The application programs could watch this event to do pre-defined tasks, like storing the data and preparing to turn off system.

Once going into HARD_OFF_DELAY stage, this process will be irreversible. And if HARD_OFF_DELAY counts to zero, the system power will be cut off abruptly.

- **Low battery protection**

To avoid draining out the car battery, low-battery protection is involved to ensure the car battery is capable to start the vehicle. When the system is ON, VPM controller will monitor the car battery voltage. If the battery voltage is lower than a programmable

threshold (LOW_THRESHOLD), VPM controller will go into LOW_DELAY stage and start to count down. During the stage of LOW_DELAY countdown, if battery voltage is back above LOW_THRESHOLD, VPM controller will stop count down and leave this stage. If LOW_DELAY counts to zero, VPM controller will send an event (power button press) to notify the system, go into LOW_HARD_DELAY stage and start to count down. Once LOW_HARD_DELAY counts to zero, VPM controller will cut off the system power abruptly to avoid draining out the car battery.

The table below lists the user programmable parameters for VPM features:

	Default value	Acceptable range
ON_DELAY	2 second	1 ~ 18000 second
OFF_EVENT_DELAY	5 second	1 ~ 18000 second
HARD_OFF_DELAY	60 second	1 ~ 18000 second
LOW_THRESHOLD (12V mode)	11.42 V	10.09 ~ 12.25 V
LOW_THRESHOLD (24V mode)	22.44 V	21.11 ~ 23.28 V
LOW_DELAY	30 second	1 ~ 3600 second
LOW_HARD_DELAY	60 second	1 ~ 3600 second

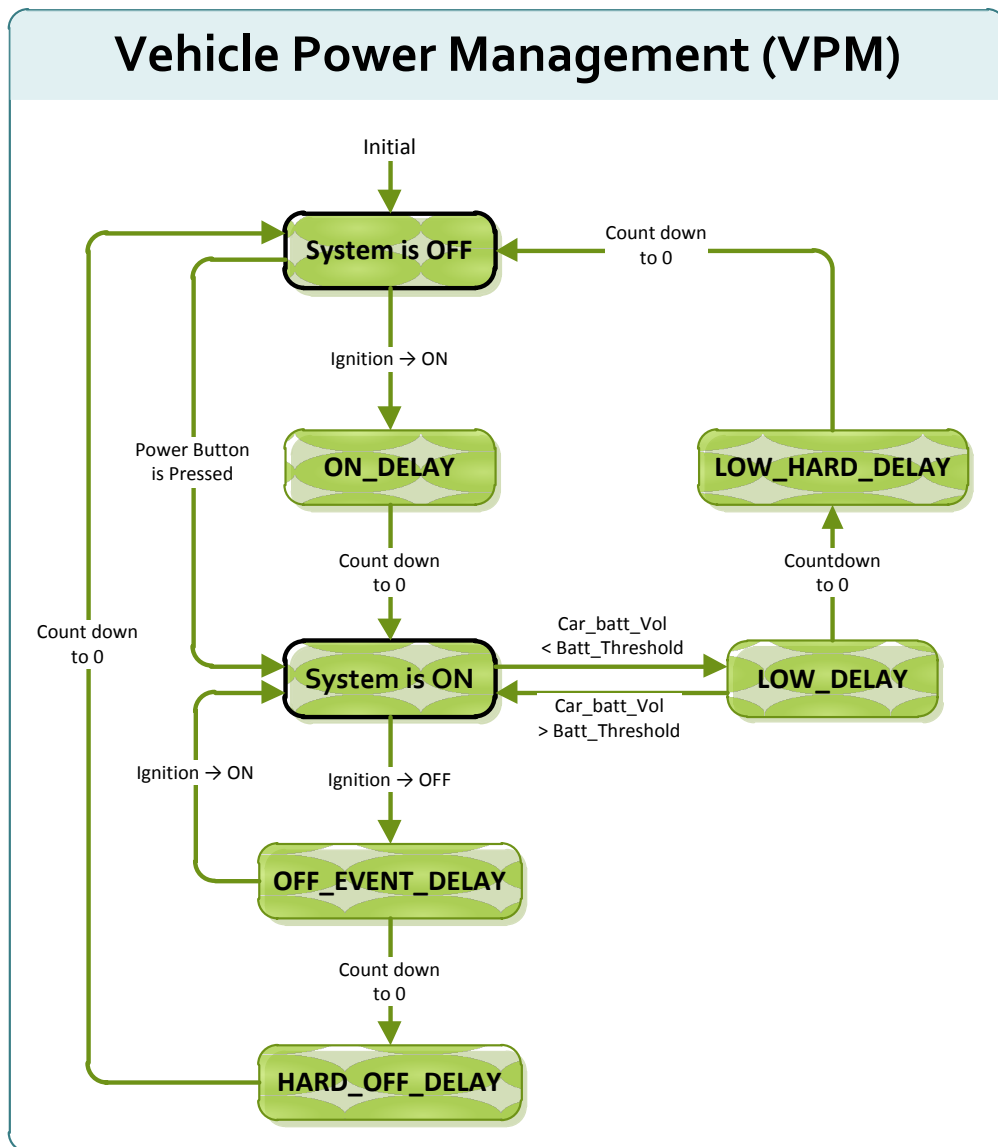

6.3.2 Power Management utility program

Execute IMCDemo.exe file, see the icon below.



6.3.3 Power Management Parameter settings

The parameters for power management on TREK-550 could be read or modified by Demo utility (see the image below) or SDK/API.

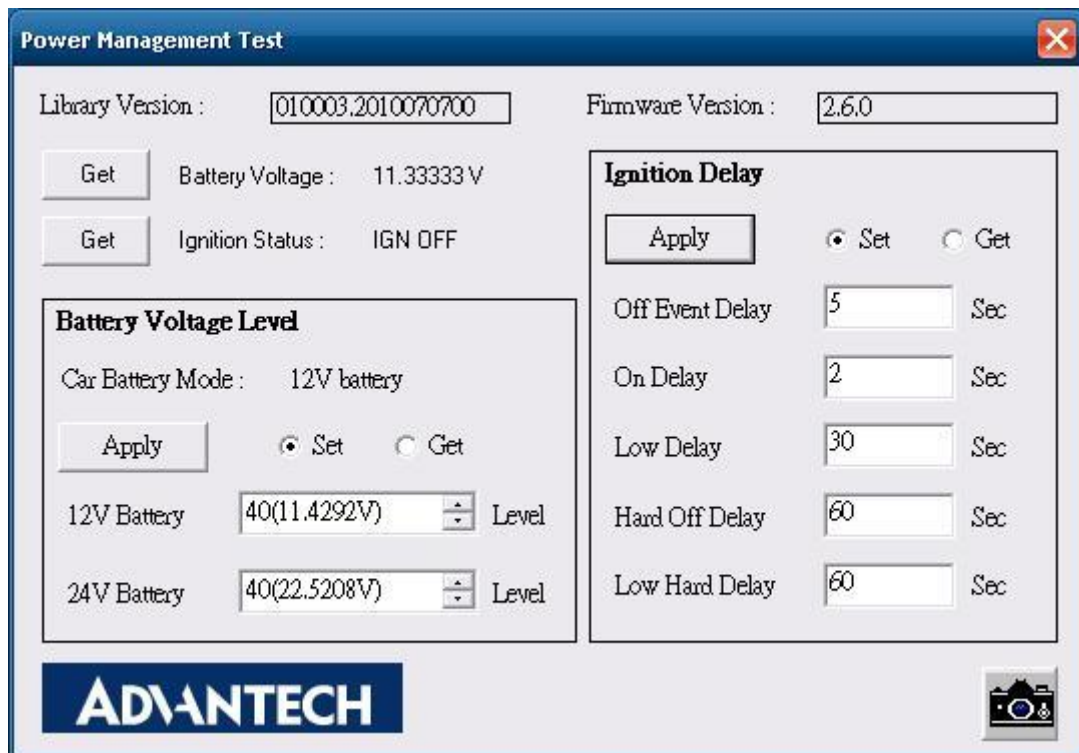

Figure 6.15 Power management test utility

6.3.4 TREK-550 power consumption

OS: Windows Embedded Standard

Burn-in test V6.0

	Idle Mode	100% Burn-in Test Mode	Off mode (S5)
w/o TREK-303H	12V / 1.04A	12V / 1.20A	12V / 1.75mA
w/ TREK-303H	12V / 1.51A	12V / 1.94A	

*Doesn't support S1, S3, S4

6.4 GPIO Test

1. Execute I/O Test, connect GPIO loopback, click Pin0→Set, the end which Read the signal, the bulb will be light up, like wise to Pin1~Pin3. Next pick Digital output to execute the same procedure. See **figure 6**.



Figure 6.16 DI/O test

- a. Digital Output → isolated relay driver output
- b. Digital Input → isolated dry contact input

For Digital In

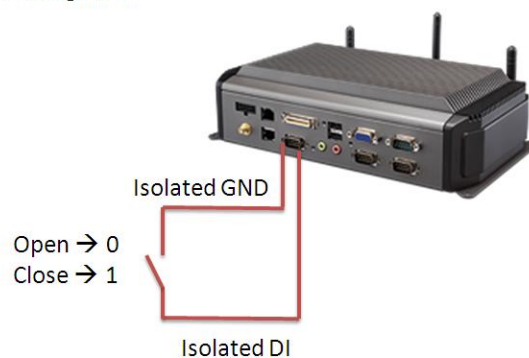
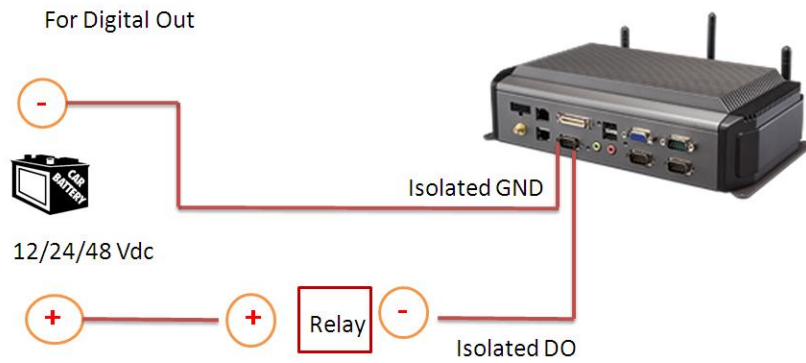

Figure 6.17 Digital in



DO could control 12/24/48 Vdc @ 150mA relay without over wheeling diode

Figure 6.18 Digital out

6.5 Video in Test

There are two video inputs, please connect camera on each port, CAM1 & CAM2, choose Channel 1 on [Switch to], then panel will show the image which camera1 has taken, it will recover to the same status after 10 sec, then change to Channel 2, Panel will show what appears on camera2, and come back to the same status after 10 sec.

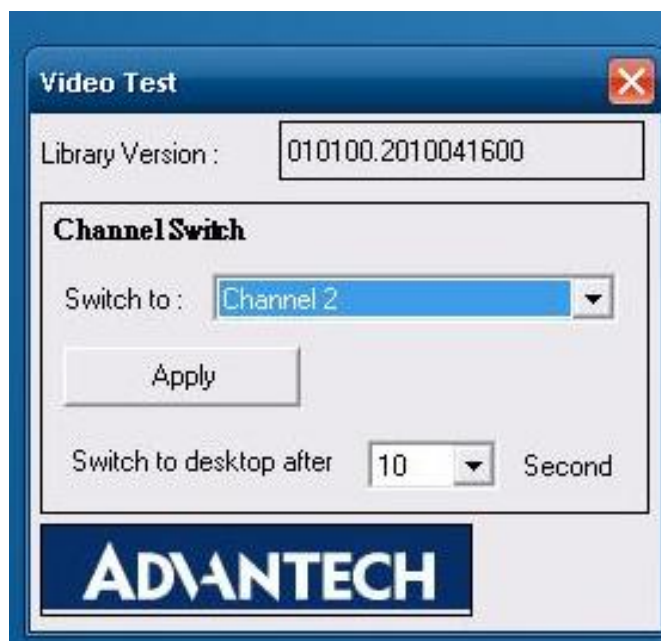

Figure 6.16 Video test utility

6.6 Dead reckoning

Dead reckoning (DR) supplements GPS satellite position information with heading and distance data provided by additional sensors. When GPS satellites

are out of sight, location is extrapolated using distance and angle information from the sensors. DR enables accurate navigation even in locations with poor or absent GPS signals such as tunnels, indoor parking facilities and deep urban canyons. In addition, DR effectively eliminates the impact of multipath effects in urban canyon environments.

6.7 G-sensor (3-axis accelerometer)

A 3-axis accelerometer is integrated in TREK-550. This could be used to characterize driver behavior such as hard accelerations, braking, and cornering. This also can tell users other significant information that can be used in accident reconstruction and etc. A code example is provided for customer reference regarding how to access and configure G-sensor. G-sensor is located on the motherboard inside the TREK-550. Please refer the link (http://www.analog.com/static/imported-files/data_sheets/ADXL345.pdf) for the G-sensor datasheet.

Appendix **A**

TREK-303

This appendix explains the
TREK-303 detailed information

Appendix A Paired with TREK-303 Specifications

TREK-303 Specification

Display	Models	TREK-303R-LA0E	TREK-303R-HA0E
	Design Compatible Models	paired with TREK-510	paired with TREK-550
	Resolution(pixel)	480 x 234	800 x 480
	Number of Colors	262 K (supports 18-bit)	262K (supports 24-bit)
	Pixel Pitch	0.107 (W) x 0.37 (H)	0.2168 (H) x 0.2168 (V)
	Brightness (cd/m ²)	500 (typical) without touchscreen	500 (typical) without touchscreen
	View Angle (R/L/B/T)	70° / 70° / 60° / 60°	70° / 70° / 60° / 60°
	Contrast Ratio	300	500
	Lamp Life (hrs)	10,000 (min)	50,000 (min)
	Lamp Type	CCFL	LED
Touchscreen	Touchscreen	4-wire resistive (GFG 4-wire design reserve)	
Front plane	Speaker	2 watts	
	Hotkey	Supports 5 hotkeys (user defined)	
	Brightness Control	Light sensing (default), manually controlled by button (optional)	
	USB Host	x 1	
Back plane	Power /Wake Up Button	Yes	
	Reset Button	Yes	
Power	DC Input	12V ± 5%	
	Power Consumption	~8W (Max.)	~7W (Max.)
Mechanical	Mounting	Design compatible with RAM mount	
	Material	PC	
	Weight	1 kg	
	Dimensions	244 x 160 x 41 mm	
	IP rating	IP54 (without I/O connector)	
Environment	Operating Temperature	-30 to + 70° C	
	Storage Temperature	-40 to + 80° C	
	Vibration	MIL-STD-810F, SAE J1455 4.9.4.2	

Note! 1. *The Brightness control is adjusted by the auto light sensor in the front panel as default; it is also defined by button on the front panel by manual.*



2. *The color LCD display*



A. USB Host

B. 5 programmable hotkeys

C. D. Brightness control

E. Power LED

F. Light sensor

G. Speaker

Note: Backlight off: Press C button to the lowest level



Pin out for TREK-303 LVDS connector

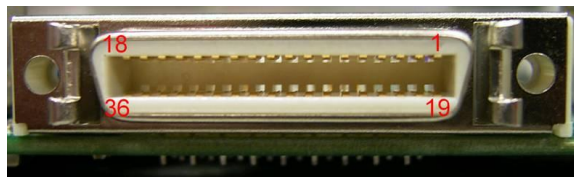
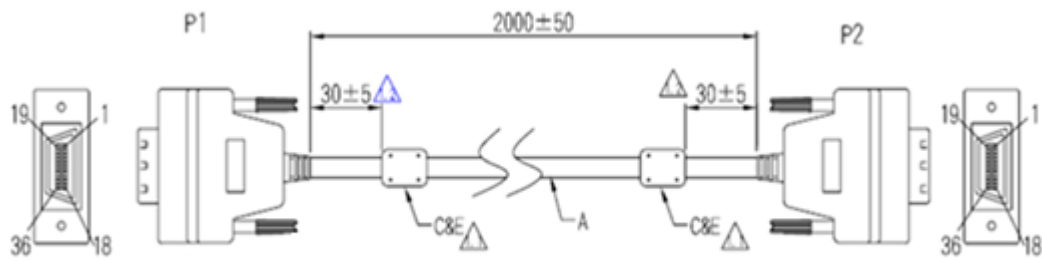

Table A.2: Smart Display Connector

Pin	Signal	Pin	Signal
1	Backlight Enable input #	2	Panel Power Enable input #
3	LVDS Ground	4	Reset Button Input #
5	LVDS Clock +	6	LVDS Clock -
7	LVDS Ground	8	LVDS Ground
9	LVDS Data2 +	10	LVDS Data2 -
11	RS232 RXD1 #	12	RS232 TXD1 #
13	LVDS Data1 +	14	LVDS Data1 -
15	LVDS Ground	16	LVDS Ground
17	LVDS Data0 +	18	LVDS Data0 -
19	USB D-	20	USB D+
21	USB Ground	22	USB Ground
23	+12VDC input (+/- 5%, max 1A)	24	+12VDC input (+/- 5%, max 1A)
25	+12VDC input (+/- 5%, max 1A)	26	+12VDC input (+/- 5%, max 1A)
27	Power Ground	28	Power Ground
29	Power Ground	30	Power Ground
31	RS232 RXD2 #	32	RS232 TXD2 #
33	RS232 RTS2	34	Power Button Input # (connect with system box)
35	Audio Ground	36	Mono. Line-in



Pin assignment

P1	1	2	3	4	5	6	7	8	9	10	11	12	13	14	15	16	17	18
P2	1	2	3	4	5	6	7	8	9	10	11	12	13	14	15	16	17	18
Color	Brown	White	Ground	Brown	red	white	Ground	Ground	Orange	white	red	Orange	yellow	white	Ground	Ground	Green	white



19	20	21	22	23	24	25	26	27	28	29	30	31	32	33	34	35	36
19	20	21	22	23	24	25	26	27	28	29	30	31	32	33	34	35	36
Blue	white	Ground	yellow	Green	Blue	Purple	Grey	white	Black	Black Brown	black red	Orange	Black Yellow	Black green	Black blue	Black purple	Black grey



TREK-303 Hotkey Utility

Execute IMC demo utility

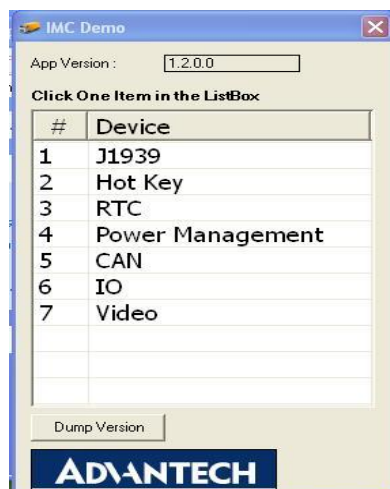

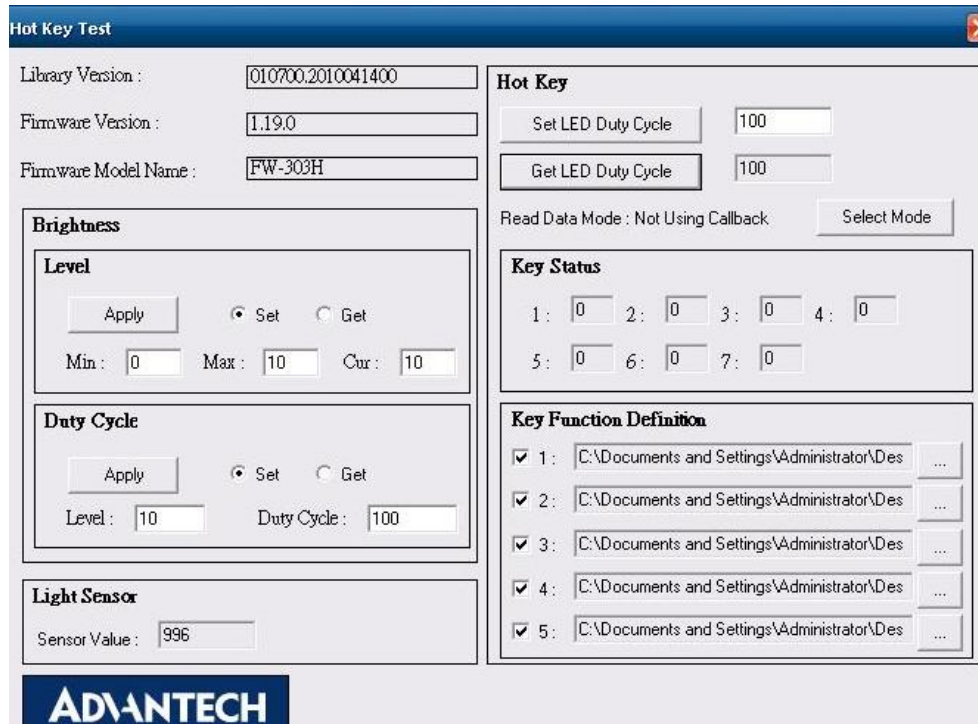

Figure A. 1 Hotkey utility

1. Execute “Hot Key test” program →
2. **Brightness level:** You may set panel’s brightness from level 0 ~10, total 10 levels, when you finish setting the brightness level you want, please click “Apply”. If you want to check the current brightness level of TREK-303, please click “Get”.
3. **Duty cycle:** You may set every level’s brightness strength, total 10 levels, when you finish setting the brightness strength for each level, please click “Apply”. If you want to check the current brightness strength on certain level of TREK-303, please click “Get”.
4. **Light sensor:** When the sensor has detected the change of the brightness in the environment, the value will change. The lowest level of brightness, the lowest value it is presented. On the contrary, the highest level of brightness, the highest value it is presented.
5. **Hotkey:** the backlight brightness of hotkeys could be adjusted by setting the value from 0 ~100.
6. **Key Status:** When you press Hot key, the status will change from 0 to 1.
7. **Key function Definition:** You may set the parameter to connect the application program of the hot key.

www.advantech.com

Please verify specifications before quoting. This guide is intended for reference purposes only.

All product specifications are subject to change without notice.

No part of this publication may be reproduced in any form or by any means, electronic, photocopying, recording or otherwise, without prior written permission of the publisher.

All brand and product names are trademarks or registered trademarks of their respective companies.

© Advantech Co., Ltd. 2010