

# **EKI-2548MI**

**6Tx + 2 Multi-Mode Managed  
Ethernet Switch with Wide  
Temperature**

## **User Manual**

## Copyright

The documentation and the software included with this product are copyrighted 2010 by Advantech Co., Ltd. All rights are reserved. Advantech Co., Ltd. reserves the right to make improvements in the products described in this manual at any time without notice. No part of this manual may be reproduced, copied, translated or transmitted in any form or by any means without the prior written permission of Advantech Co., Ltd. Information provided in this manual is intended to be accurate and reliable. However, Advantech Co., Ltd. assumes no responsibility for its use, nor for any infringements of the rights of third parties, which may result from its use.

All other product names or trademarks are properties of their respective owners.

## **Product Warranty (2 years)**

Advantech warrants to you, the original purchaser, that each of its products will be free from defects in materials and workmanship for two years from the date of purchase.

This warranty does not apply to any products which have been repaired or altered by persons other than repair personnel authorized by Advantech, or which have been subject to misuse, abuse, accident or improper installation. Advantech assumes no liability under the terms of this warranty as a consequence of such events.

Because of Advantech's high quality-control standards and rigorous testing, most of our customers never need to use our repair service. If an Advantech product is defective, it will be repaired or replaced at no charge during the warranty period. For out-of-warranty repairs, you will be billed according to the cost of replacement materials, service time and freight. Please consult your dealer for more details.

If you think you have a defective product, follow these steps:

1. Collect all the information about the problem encountered. (For example, Network speed, Advantech products used, other hardware and software used, etc.) Note anything abnormal and list any onscreen messages you get when the problem occurs.
2. Call your dealer and describe the problem. Please have your manual, product, and any helpful information readily available.
3. If your product is diagnosed as defective, obtain an RMA (return merchandise authorization) number from your dealer. This allows us to process your return more quickly.
4. Carefully pack the defective product, a fully-completed Repair and Replacement Order Card and a photocopy proof of purchase date (such as your sales receipt) in a shippable container. A product returned without proof of the purchase date is not eligible for warranty service.
5. Write the RMA number visibly on the outside of the package and ship it prepaid to your dealer.

## **Declaration of Conformity**

### **CE**

This product has passed the CE test for environmental specifications. Test conditions for passing included the equipment being operated within an industrial enclosure. In order to protect the product from being damaged by ESD (Electrostatic Discharge) and EMI leakage, we strongly recommend the use of CE-compliant industrial enclosure products.

### **FCC Class A**

This equipment has been tested and found to comply with the limits for a Class A digital device, pursuant to Part 15 of the FCC Rules. These limits are designed to provide reasonable protection against harmful interference when the equipment is operated in a commercial environment. This equipment generates, uses and can radiate radio frequency energy and, if not installed and used in accordance with the instruction manual, may cause harmful interference to radio communications. Operation of this equipment in a residential area is likely to cause harmful interference in which case the user will be required to correct the interference at his own expense.

## **Technical Support and Assistance**

- Step 1. Visit the Advantech web site at [www.avanotech.com/support](http://www.avanotech.com/support) where you can find the latest information about the product.
  
- Step 2. Contact your distributor, sales representative, or Advantech's customer service center for technical support if you need additional assistance. Please have the following information ready before you call:
  - Product name and serial number
  - Description of your peripheral attachments
  - Description of your software (operating system, version, application software, etc.)
  - A complete description of the problem
  - The exact wording of any error messages

## Safety Instructions

1. Read these safety instructions carefully.
2. Keep this User's Manual for later reference.
3. Disconnect this equipment from any AC outlet before cleaning. Use a damp cloth. Do not use liquid or spray detergents for cleaning.
4. For plug-in equipment, the power outlet socket must be located near the equipment and must be easily accessible.
5. Keep this equipment away from humidity.
6. Put this equipment on a reliable surface during installation. Dropping it or letting it fall may cause damage.
7. The openings on the enclosure are for air convection. Protect the equipment from overheating. **DO NOT COVER THE OPENINGS.**
8. Make sure the voltage of the power source is correct before connecting the equipment to the power outlet.
9. Position the power cord so that people cannot step on it. Do not place anything over the power cord.
10. All cautions and warnings on the equipment should be noted.
11. If the equipment is not used for a long time, disconnect it from the power source to avoid damage by transient over voltage.
12. Never pour any liquid into an opening. This may cause fire or electrical shock.
13. Never open the equipment. For safety reasons, the equipment should be opened only by qualified service personnel.
14. If one of the following situations arises, get the equipment checked by service personnel:
  - a. The power cord or plug is damaged.
  - b. Liquid has penetrated into the equipment.
  - c. The equipment has been exposed to moisture.
  - d. The equipment does not work well, or you cannot get it to work according to the user's manual.
  - e. The equipment has been dropped and damaged.
  - f. The equipment has obvious signs of breakage.
15. **DO NOT LEAVE THIS EQUIPMENT IN AN ENVIRONMENT WHERE THE STORAGE TEMPERATURE MAY GO BELOW -40°C (-40°F) OR ABOVE 85°C (185°F). THIS COULD DAMAGE THE EQUIPMENT. THE EQUIPMENT SHOULD BE IN A CONTROLLED ENVIRONMENT.**

# Contents

<b>Chapter 1</b>	<b>Overview.....</b>	<b>2</b>
1.1	Introduction.....	2
1.1.1	High-Speed Transmissions .....	2
1.1.2	Dual Power Inputs .....	2
1.1.3	Flexible Mounting .....	2
1.1.4	Wide Operating Temperature.....	2
1.1.5	Easy Troubleshooting.....	2
1.2	Features .....	3
1.3	Specification .....	4
1.4	Packing List .....	6
1.5	Safety Precaution .....	6
<b>Chapter 2</b>	<b>Installation.....</b>	<b>8</b>
2.1	LED Indicators.....	8
	Table 2.1: EKI-2548MI LED Definition.....	8
2.2	DIP Switch.....	9
2.3	Reset Button.....	9
2.4	Dimensions (units: mm).....	10
	Figure 2.1: Front View of EKI-2548MI .....	10
	Figure 2.2: Side View of EKI-2548MI.....	11
	Figure 2.3: Rear View of EKI-2548MI .....	12
	Figure 2.4: Top View of EKI-2548MI .....	13
2.5	Mounting.....	14
2.5.1	Wall mounting .....	14
	Figure 2.5: Combine the Metal Mounting Kit.....	14
2.5.2	DIN-rail Mounting .....	15
	Figure 2.6: Installation to DIN-rail Step 1.....	15
	Figure 2.7: Installation to DIN-rail Step 2.....	16
2.6	Power Connection .....	17
	Figure 2.8: Pin Assignments of the Power Connector.....	17
<b>Chapter 3</b>	<b>Configuration .....</b>	<b>20</b>
3.1	Web Browser.....	20
	Figure 3.1: Type the address in the URL.....	20
	Figure 3.2: Web Login Window .....	20
	Figure 3.3: Main page.....	21
3.1.1	System .....	21
	Figure 3.4: Switch Settings.....	22
	Figure 3.5: IP Configuration.....	22
	Figure 3.6: TFTP – Update Firmware .....	23
	Figure 3.7: System Log Configuration .....	24
	Figure 3.8: Event Configuration .....	25
	Table 3.1: UTC Timezone .....	25
	Figure 3.9: SNTP Configuration .....	27
	Figure 3.10: IP Security.....	27
	Figure 3.11: Security Manager .....	28

Figure 3.12: Email Alert Configuration .....	29
Figure 3.13: Event Configuration .....	30
Figure 3.14: Power Alarm Configuration.....	30
<b>3.1.2 Port.....</b>	<b>31</b>
Figure 3.15: Port Status .....	31
Figure 3.16: Port Statistics.....	32
Figure 3.17: Port Control.....	33
Figure 3.18: Port Mirroring .....	33
Figure 3.19: Rate Control .....	34
<b>3.1.3 Protocol .....</b>	<b>35</b>
Figure 3.20: VLAN Configuration .....	35
Figure 3.21: Port-based Mode .....	36
Figure 3.22: Port-based Mode--Add.....	36
Figure 3.23: Port-based Edit/Delete .....	37
Figure 3.24: 802.1Q VLAN Configuration .....	38
Figure 3.25: Adding an 802.1Q VLAN.....	39
Figure 3.26: Tag/Untag Member Ports.....	39
Figure 3.27: Port VLAN ID Setting .....	40
Figure 3.28: RSTP System Configuration.....	41
Figure 3.29: RSTP Port Configuration .....	42
Figure 3.30: SNMP Configuration .....	43
Figure 3.31: QoS Configuration .....	45
Table 3.2: IGMP types.....	45
Figure 3.32: IGMP Configuration .....	46
Figure 3.33: X-ring .....	47
<b>3.1.4 Configuration Backup .....</b>	<b>48</b>
Figure 3.34: TFTP Restore Configuration.....	48
Figure 3.35: TFTP Backup Configuration.....	48
<b>3.1.5 Factory Default .....</b>	<b>49</b>
Figure 3.36: Factory Default .....	49
<b>3.1.6 Save Configuration .....</b>	<b>49</b>
Figure 3.37: Save Configuration .....	49
<b>3.1.7 System Reboot.....</b>	<b>49</b>
Figure 3.38: System Reboot .....	49
<b>Chapter 4 Troubleshooting .....</b>	<b>52</b>
<b>Appendix A Pin Assignments &amp; Wiring .....</b>	<b>54</b>
<b>A.1 RJ-45 Port .....</b>	<b>54</b>
Figure A.1: RJ-45 Pin Assignments .....	54
Figure A.2: EIA/TIA-568B .....	55
Figure A.3: EIA/TIA-568A .....	55
<b>A.2 Fiber Port.....</b>	<b>56</b>





## Overview

Sections include:

- Introduction
- Features
- Specifications
- Packing List
- Safety Precaution

# Chapter 1 Overview

## 1.1 Introduction

---

To create reliability in your network, the EKI-2548MI comes equipped with a proprietary redundant network protocol—X-Ring that was developed by Advantech, which provides users with an easy way to establish a redundant Ethernet network with ultra high-speed recovery time less than 10 ms.

Aside from 6 x 10/100Base-T(X) Fast Ethernet ports, the EKI-2548MI comes equipped with 2 100Mbps fiber expansion ports. The fiber ports can be used for the application of wideband uploading and long distance transmissions to fit the field request flexibility.

### 1.1.1 High-Speed Transmissions

The EKI-2548MI includes a switch controller that can automatically sense transmission speeds (10/100 Mbps). The RJ-45 interface can also be auto-detected, so MDI or MDI-X is automatically selected and a crossover cable is not required. All Ethernet ports have memory buffers that support the store-and-forward mechanism. This assures that data is properly transmitted.

### 1.1.2 Dual Power Inputs

To reduce the risk of power failure, EKI-2548MI provides +12 ~ 48 V<sub>DC</sub> or 24 V<sub>AC</sub> (18 ~ 30 V<sub>AC</sub>) dual power inputs. If there is power failure, EKI-2548MI will automatically switch to the secondary power input.

### 1.1.3 Flexible Mounting

EKI-2548MI is compact and can be mounted on a DIN-rail or panel, so it is suitable for any space-constrained environment.

### 1.1.4 Wide Operating Temperature

The operating temperature of the EKI-2548MI is between -40 ~ 75°C. With such a wide range, you can use the EKI-2548MI in some of the harshest industrial environments that exist.

### 1.1.5 Easy Troubleshooting

LED indicators which make troubleshooting quick and easy help you diagnose the system immediately.

## 1.2 Features

---

- Provides 6 x 10/100 Mbps Ethernet ports with RJ45 connector
- Provides 2 x 100 Mbps multi-mode SC type fiber ports
- Redundancy: X-Ring, Dual Homing, Couple Ring, IEEE802.1d STP & IEEE802.1w RSTP
- Management: Web, SNMP v1/v2c
- Traffic Control: IGMP Snooping, Query for multicast group management, Rate limit and storm control
- Security: IP Access Security
- Diagnostics: Port Mirroring, STMP, SNMP Trap, E-mail Alert, System log
- Dual 12 ~ 48 V<sub>DC</sub> /24V<sub>AC</sub> power inputs and 1 Relay Output
- Supports operating temperatures from -40 ~ 75°C
- Robust mechanism and special heat spreader design

## 1.3 Specification

---

### Communications

<b>Standard</b>	IEEE 802.3, 802.3u, 802.3x IEEE 802.1d, 802.1p, 802.1Q, 802.1w
<b>LAN</b>	10/100Base-TX, 100Base-FX
<b>Transmission Distance</b>	Ethernet: Up to 100m (4-wire Cat.5e, Cat.6 RJ-45 cable suggested) SC Fiber (Multi-Mode, 62.5/125um, 50/125um): Up to 2km
<b>Transmission Speed</b>	Up to 100Mbps

### Interface

<b>Connectors</b>	6 x RJ-45 2 x SC type fiber connectors 6-pin terminal block (Power & Relay)
<b>LED Indicators</b>	System: PWR1, PWR2, R.M., P-Fail Copper: Link/Activity, Speed Fiber: Link/Activity

### Network Management

<b>Configuration</b>	Web browser, SNMP v1/v2c
<b>VLAN</b>	IEEE 802.1Q, GVRP, Port-based VLAN
<b>Redundancy</b>	ADVANTECH X-Ring (Recovery time < 20ms), Dual Homing, Couple Ring, 802.1w/d RSTP/STP
<b>Security</b>	IP Access Security
<b>Traffic Control</b>	IGMP Snooping/Query for multicast group management, Rate limit and storm control
<b>Diagnostics</b>	Port Mirroring, SNTP, System log, E-Mail Alert, SNMP Trap, RMON

### Power

<b>Power Consumption</b>	10.6 Watts max. @ 48 V <sub>DC</sub> 9.5 Watts max. @ 24 V <sub>AC</sub> / 60Hz
<b>Power Input</b>	2 x Unregulated +12 ~ 48 VDC, 24VAC (18~30V)
<b>Relay Output</b>	1 Relay alarm output

### Mechanism

**Dimensions (WxHxD)**  
**Enclosure**  
**Mounting**

59.6 x 152 x 105 mm  
IP30, metal shell with solid mounting kits  
DIN-rail, wall-mount

**Environment**

**Operating Temperature**

-40 ~ 75°C  
-40 ~ 60°C (non-air-flow environment)

**Operating Humidity**

5 ~ 95% (non-condensing)

**Storage Temperature**

-40 ~ 85°C

**Storage Humidity**

5 ~ 95% (non-condensing)

**Certifications**

**Safety**

UL/cUL  
UL 508  
Class I, Division 2, Group A, B, C and D

**EMC**

FCC Class A,  
CE EN61000-6-4  
CE EN61000-6-2  
CE EN61000-4-2 (ESD)  
CE EN61000-4-3 (RS)  
CE EN61000-4-4 (EFT)  
CE EN61000-4-5 (Surge)  
CE EN61000-4-6 (CS)  
CE EN61000-4-8 (Magnetic Field)  
CE EN61000-4-11 (Voltage DIP)  
CE EN61000-3-2 (Harmonics Current)  
CE EN61000-3-3 (Voltage Fluctuation & Flickers)

**Free Fall**

IEC60068-2-32

**Shock**

IEC60068-2-27

**Vibration**

IEC60068-2-6

## 1.4 Packing List

---

- 1 x EKI-2548MI Industrial Managed Fast Ethernet Switch
- 1 x eAutomation Industrial Communication CD-ROM and User manual
- 2 x Wall Mounting Bracket and Screws
- 1 x DIN-rail Mounting Bracket and Screws
- 1 x DC Jack Cable  $\varphi$  2.0/150mm
- 1 x EKI-2548MI Startup Manual

## 1.5 Safety Precaution

---

*Attention*    *IF DC voltage is supplied by an external circuit, please use a protection device on the power supply input.*

## **Installation**

Sections include:

- LED Indicators
- DIP Switch
- Reset Button
- Dimensions
- Mounting
- Power Connection

## Chapter 2 Installation

In this chapter, you will be given an overview of the EKI-2548MI hardware installation procedures.

### 2.1 LED Indicators

The LED indicators located on the front panel display the power status and network status of EKI-2548MI; each has its own specific meaning as the table shown below.

<i>Table 2.1: EKI-2548MI LED Definition</i>			
LED	Color	Description	
R-Master	Green	On	The industrial switch is the master of the X-ring group
		Off	Non-master device of the X-ring group
PWR1	Green	On	Power input 1 is active
		Off	Power input 1 is inactive
PWR2	Green	On	Power input 2 is active
		Off	Power input 2 is inactive
P-Fail	Red	On	Power input 1 or 2 is inactive or port link down (depends on Fault Relay Alarm configuration)
		Off	No failure occurs
P7 ~ P8 (Link/Active)	Green	On	Fiber port is linking
		Flashing	Data is transmitting/receiving
		Off	Not connected to network
P1 ~ P6 (Link/Active, Upper LED)	Green	On	Connected to network
		Flashing	Data is transmitting or receiving
		Off	Not connected to network
P1 ~ P6 (Speed, Lower LED)	Green	On	The port is active operating at speed of 100M
		Off	The port is active operating at speed of 10M



## 2.2 DIP Switch

---

The 6 10/100TX + 2 100FX Managed Industrial Switch provides a 9-pole DIP switch for configuring the relay alarm operation mode and the master ring operation mode. The user can enable the managed industrial switch as the ring master in the X-Ring group and R-Master LED indicator will light up. If the user enables the Port Alarm function, the P-Fail LED indicator will light up when link-down event of the respective port occurs. Each pole of the DIP switch is set to **OFF** by default.

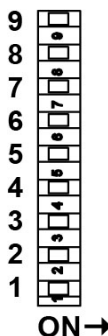

Pole No.	Status	Description
Pole 1 ~ 8	On	Enable Port Alarm for P1 ~ P8
	Off	Disable Port Alarm for P1 ~ P8
Pole 9	On	Disable the ring master function
	Off	Enable the managed industrial switch as the ring master device in the X-Ring group

*DIP switch definition*

## 2.3 Reset Button

---

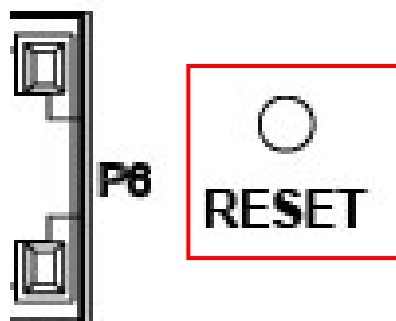

*Reset Button*

EKI-2548MI provides users a quick and easy way to restart the system or reset the configuration back to default value by pressing the reset button.

- **Restart:** press the button for 2 seconds and then release to restart the system.
- **Set to factory default value:** by pressing the button for 5 seconds, the switch will set all configurations back to default setting.

## 2.4 Dimensions (units: mm)

---

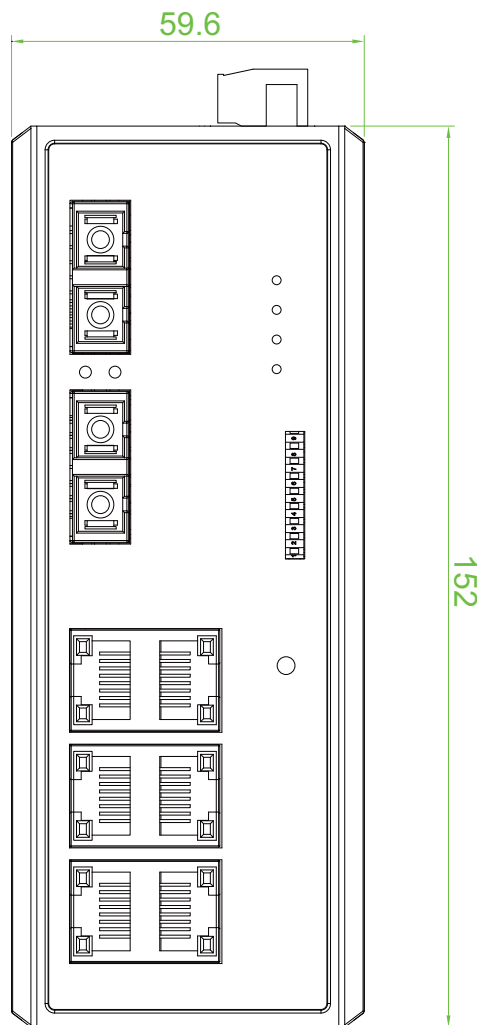

Figure 2.1: Front View of EKI-2548MI

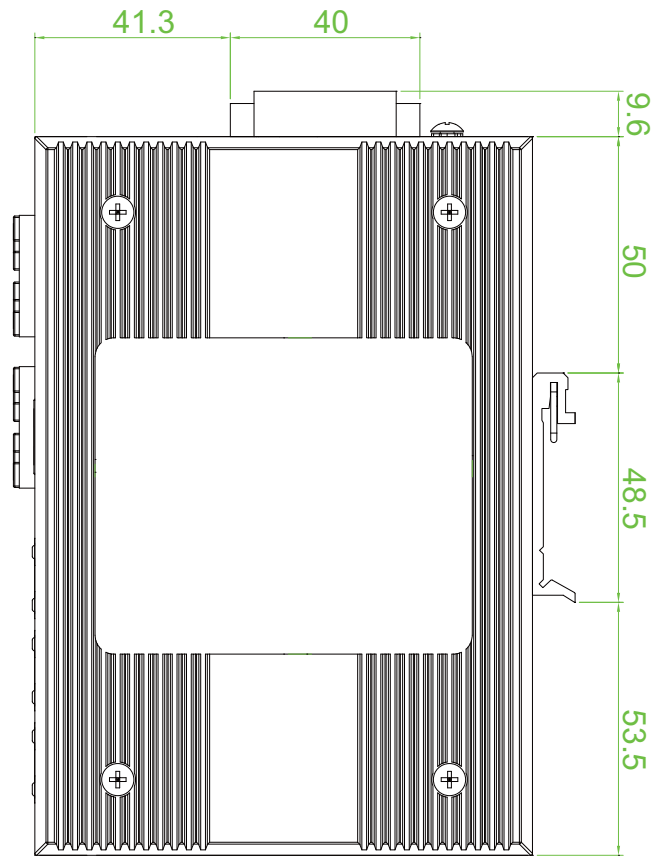

Figure 2.2: Side View of EKI-2548MI

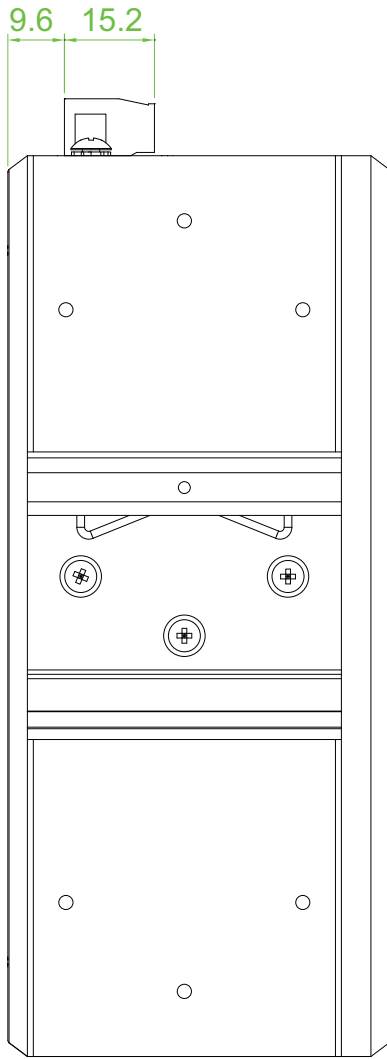

Figure 2.3: Rear View of EKI-2548MI

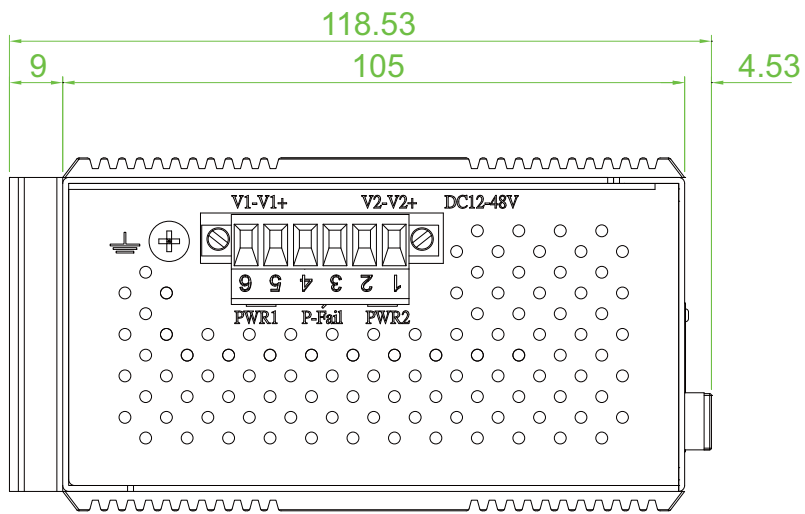

Figure 2.4: Top View of EKI-2548MI

## 2.5 Mounting

---

The EKI-2548MI supports two mounting methods: DIN-rail & Wall mounting.

### 2.5.1 Wall Mounting

EKI-2548MI can be wall-mounted by using the included mounting kit. Then, hang on the EKI-2548MI to the nails on the wall.

First, use the screws included in the package to combine the EKI-2548MI and metal mounting kit. And then you can install the device firmly via the components, please see Figure 2.5 as below.

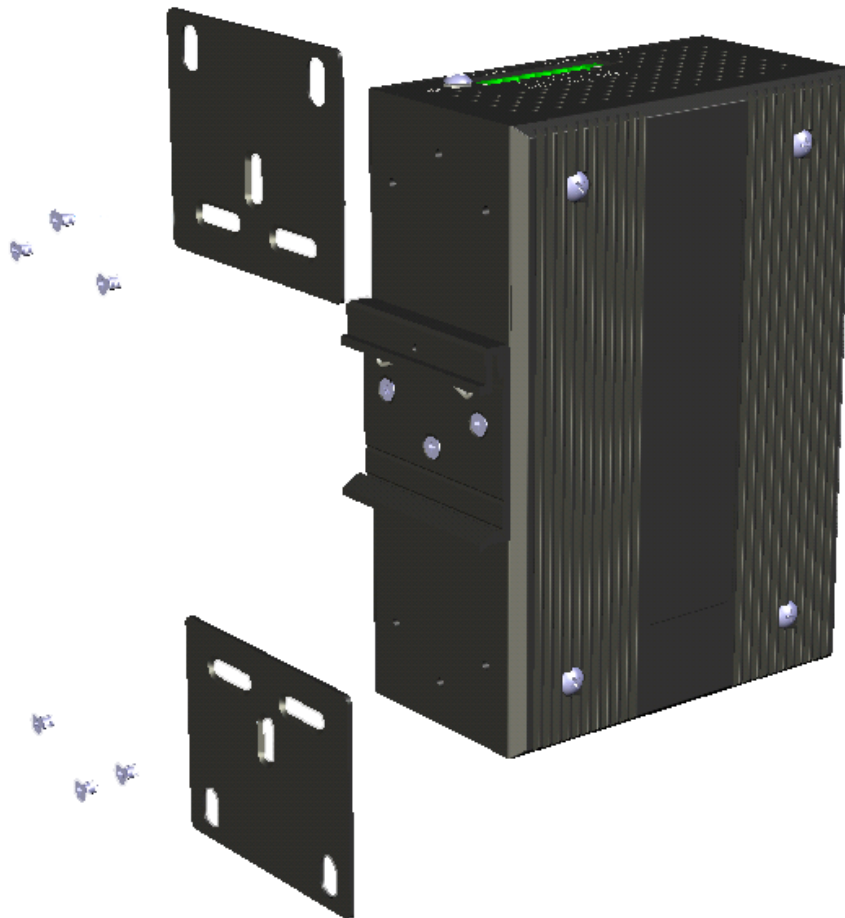

*Figure 2.5: Combine the Metal Mounting Kit*

## 2.5.2 DIN-rail Mounting

You can also mount EKI-2548MI on a standard DIN-rail by the steps below.

The DIN-rail kit is screwed on the industrial switch when out of factory. If the DIN-rail kit is not screwed on the industrial switch, please screw the DIN-rail kit on the switch first.

First, hang the EKI-2548MI to the DIN-rail with angle of inclination. See Figure 2.6.



*Figure 2.6: Installation to DIN-rail Step 1*

Then, let the device down straight to slide over the rail smoothly. See Figure 2.7.



*Figure 2.7: Installation to DIN-rail Step 2*



## 2.6 Power Connection

The EKI-2548MI supports dual +12 ~ 48 V<sub>DC</sub> and 24 V<sub>AC</sub> power inputs, and power-fail relay output.

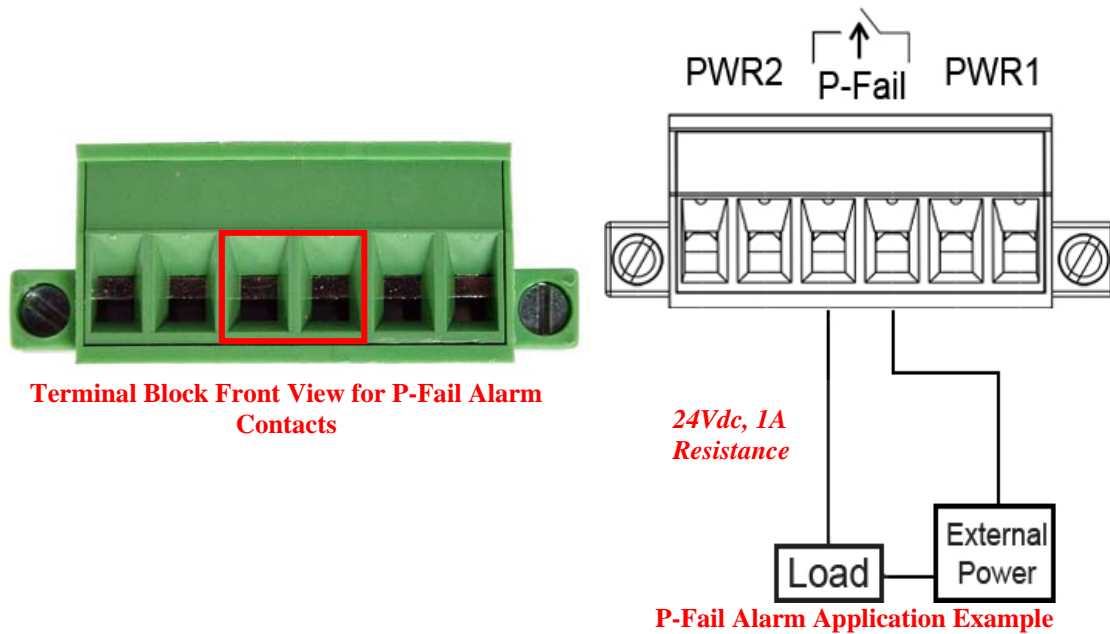

Figure 2.8: Pin Assignments of the Power Connector

You can connect an alarm indicator, buzzer or other signaling equipment through the relay output. The relay opens if power input 1, 2 fails or port link down/break ("Open" means if you connect relay output with an LED, the light would be off).



## **Configuration**

Sections include:

- Web Browser

# Chapter 3 Configuration

## 3.1 Web Browser

---

EKI-2548MI provides a convenient configuring way via web browser. You can follow the steps below to access EKI-2548MI.

EKI-2548MI's default IP is 192.168.1.1. Make sure your host PC and EKI-2548MI are on the same logical sub-network.

*Warning*                      *Your host PC should be in the same VLAN setting with EKI-2548MI, or the management will not be configured.*

Connect EKI-2548MI to the Ethernet then your host PC could be configured via Ethernet. Or you can directly connect EKI-2548MI to your host PC with a straight-through or cross over Ethernet cable.

Before to use web management, install the industrial switch on the network and make sure that any one of PCs on the network can connect with the industrial switch through the web browser. The industrial switch default value of IP, subnet mask, username and password are as follows:

- IP Address: 192.168.1.1
- Subnet Mask: 255.255.255.0
- Default Gateway: 192.168.1.254
- User Name: admin
- Password: admin

Open Internet Explorer and type EKI-2548MI's IP in the Address field then press Enter to open the web login page.



Figure 3.1: Type the address in the URL



Figure 3.2: Web Login Window

The default user name and password are both **admin**, fill in the user name and password then press **OK** to enter the configuration. You can change the password in the system setting.

In the main page, you can find the tree menu structure of the EKI-2548MI in the left side. Click the “+” symbol to unroll the hiding hyperlink, and click the hyperlink to open the function page you want to configure.

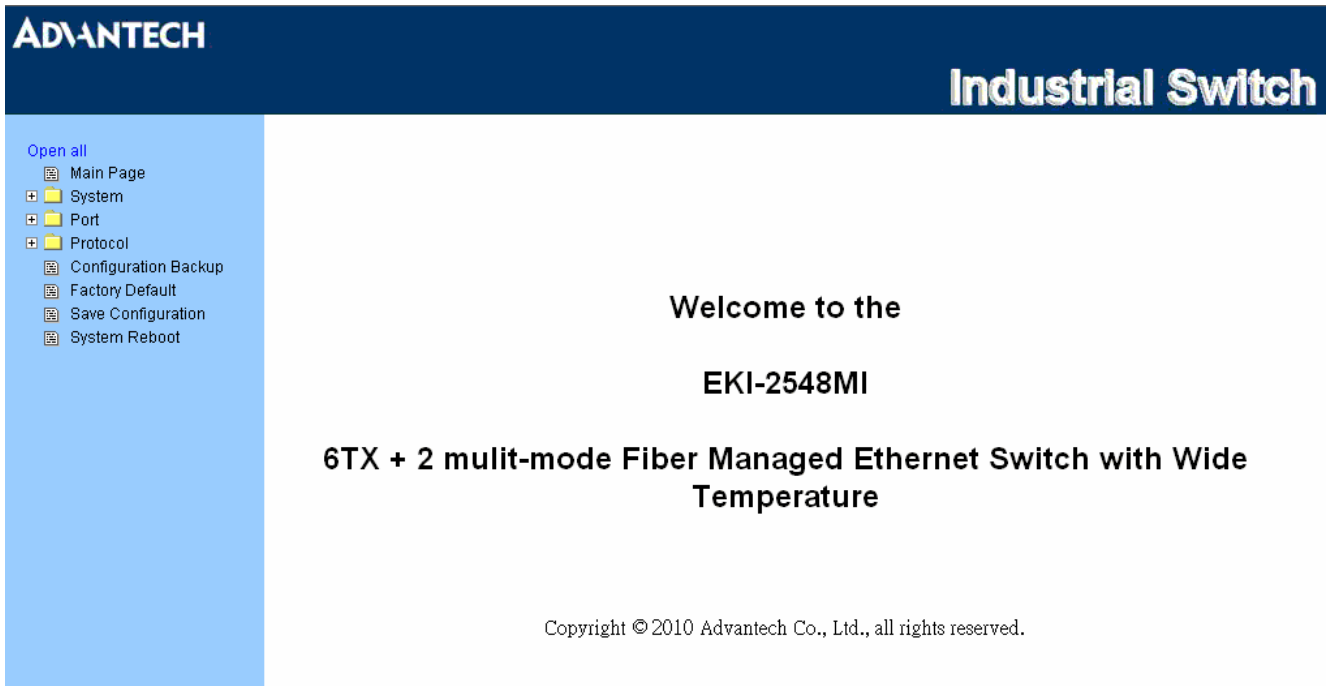

Figure 3.3: Main page

### 3.1.1 System

#### Switch Settings

This page displays system information and gives users the interface to assign the system name, location, system contact, etc.

- **System Description:** Displays the description of switch. Read only cannot be modified.
- **System Name:** Assign the name of the switch. The maximum length is 64 bytes.
- **System Location:** Assign the switch physical location. The maximum length is 64 bytes.
- **System Contact:** Enter the name of contact person or organization.
- **Firmware Version:** Displays the switch's firmware version.
- **Kernel Version:** Displays the kernel software version.
- **Hardware Version:** Displays the hardware version of the device.
- **MAC Address:** Displays the unique hardware address assigned by manufacturer (default).

#### Warning

*Don't set "0" for the first segment of the subnet mask and default gateway (000.xxx.xxx.xxx). Refresh the web screen if the web could not be displayed while you change the setting.*

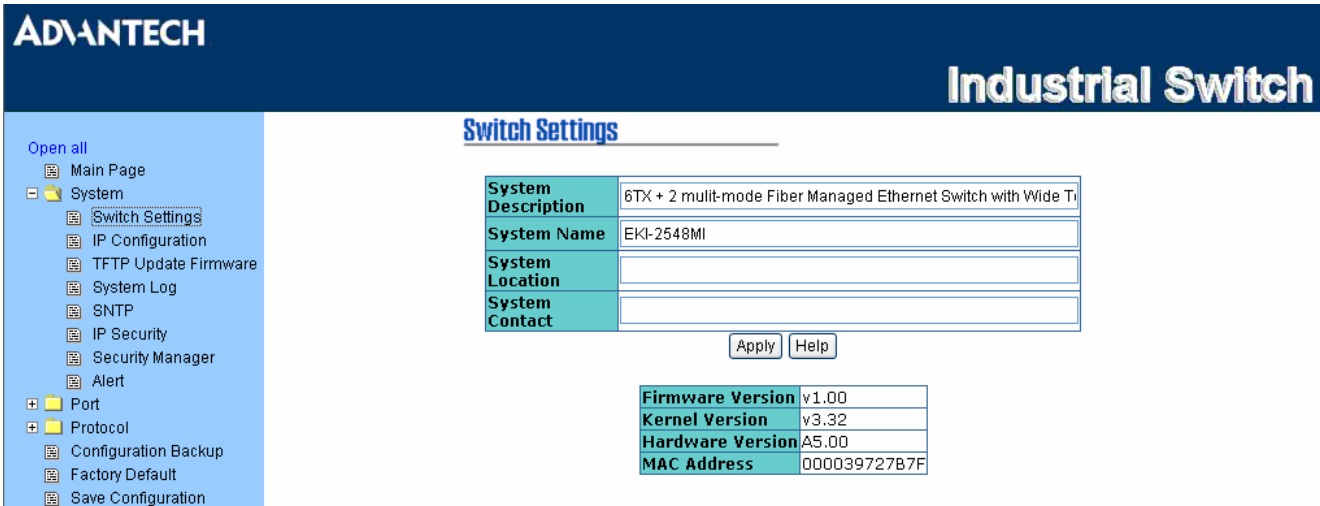

Figure 3.4: Switch Settings

## IP Configuration

Users can configure the IP Settings and DHCP client function here.

- **DHCP Client:** Enable or disable the DHCP client function. When DHCP client is enabled, the industrial switch will be assigned an IP address from the network DHCP server. The default IP address will be replaced by the assigned IP address from DHCP server. After users click the **Apply** button, a popup dialog shows up. It is to inform the user that when the DHCP client is enabled, the current IP will lose and the user should find the new IP on the DHCP server.
- **IP Address:** Assign the IP address that the network is using. If DHCP client is enabled, users don't need to assign the IP address, and the network DHCP server will assign the IP address displaying in this column for the industrial switch. The default IP is 192.168.16.1.
- **Subnet Mask:** Assign the subnet mask to the IP address. If DHCP client is enabled, users don't need to assign the subnet mask.
- **Gateway:** Assign the network gateway for the industrial switch. The default gateway is 192.168.16.254.
- And then, click

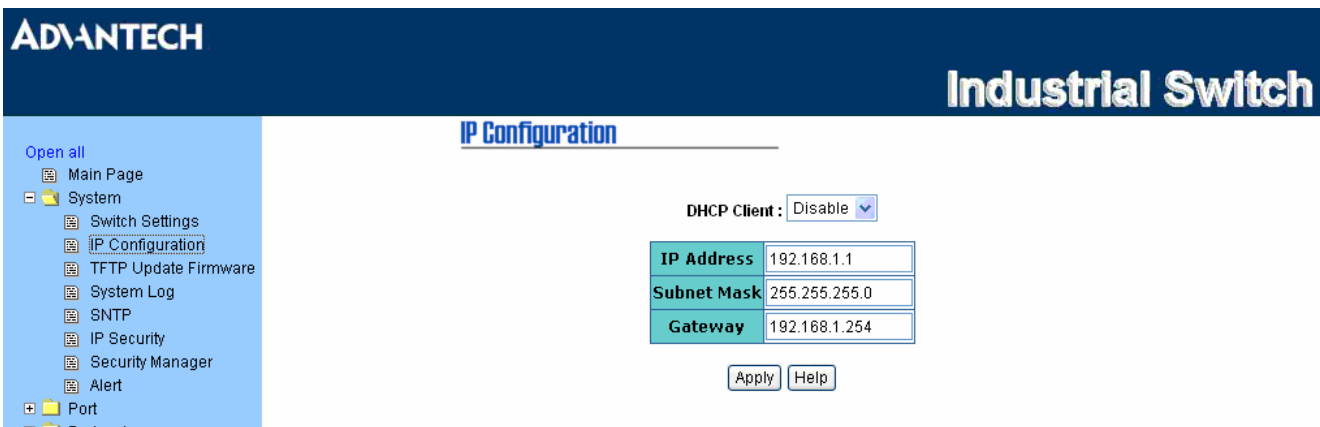

Figure 3.5: IP Configuration

## TFTP - Update Firmware

Trivial File Transfer Protocol (TFTP) is a very simple file transfer protocol with the functionality of a very basic form of FTP. It provides functions allowing the user to update the switch firmware. Before updating, make sure you have your TFTP server ready and the firmware image is on the TFTP server.

- **TFTP Server IP Address:** Fill in your TFTP server IP.
- **Firmware File Name:** Type in the name of firmware image.
- And then, click

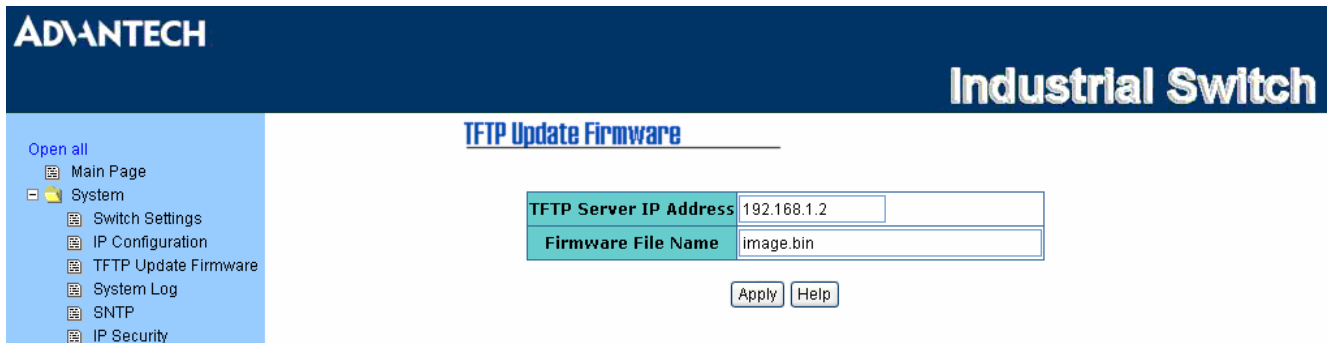

Figure 3.6: TFTP – Update Firmware

### System Log – System Log Configuration

Configure the system event mode to collect system log.

- **System Log Mode:** Select the system log mode—**Client Only**, **Server Only**, or **Both**.
- **System Log Server IP:** Assign the system log server IP.
- When System Log Mode is set to **Client Only**, the system event log will only be reserved in the switch’s RAM until next reboot. When the mode is set to **Server Only**, the system log will only be sent to the system log server, and therefore you have to type the IP address in the System Log Server IP column. If the mode is set to **Both**, the system log will be reserved in the switch’s RAM and sent to the specific server.
- Click  to refresh the events log.
- Click  to clear all current events log.
- After configuring, click .

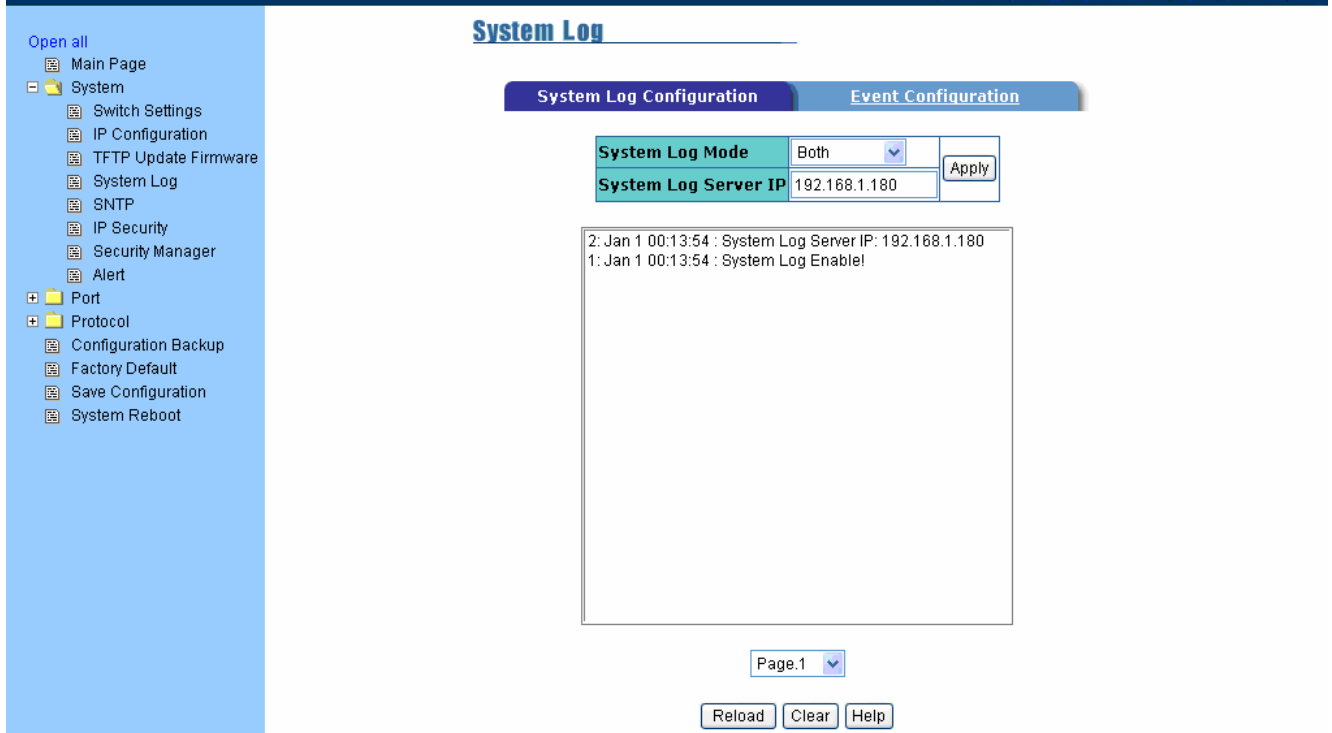

Figure 3.7: System Log Configuration

### System Log – Event Configuration

- **System event selection:** There are 4 event types—Device cold start, Power status, SNMP Authentication Failure, and X-ring topology change. Tick the check box beside the event label to collect the log information.
  - **Device cold start:** When the device executes cold start action, the system will issue a log event.
  - **Power status:** When the power status of the device changes, the system will issue a log event.
  - **SNMP Authentication Failure:** When the SNMP authentication fails, the system will issue a log event.
  - **X-ring topology change:** When the X-ring topology has changed, the system will issue a log event.
  
- **Port event selection:** The drop-down menus have 3 selections—Link UP, Link Down, and Link UP & Link Down. Disable means no event will be sent.
  - **Link UP:** The system will issue a log message when port connection links up.
  - **Link Down:** The system will issue a log message when port connection links down.
  - **Link UP & Link Down:** The system will issue a log message when port connection is up and down.



Figure 3.8: Event Configuration

### SNTP Configuration

You can configure the SNTP (Simple Network Time Protocol) settings which allow you to synchronize the switch clock with an Internet time server.

- **UTC Timezone:** Set the switch location time zone. The following table lists the different location time zone for your reference.

*Table 3.1: UTC Timezone*

Local Time Zone	Conversion from UTC	Time at 12:00 UTC
November Time Zone	- 1 hour	11am
Oscar Time Zone	-2 hours	10 am
ADT - Atlantic Daylight	-3 hours	9 am
AST - Atlantic Standard EDT - Eastern Daylight	-4 hours	8 am
EST - Eastern Standard CDT - Central Daylight	-5 hours	7 am
CST - Central Standard MDT - Mountain Daylight	-6 hours	6 am
MST - Mountain Standard PDT - Pacific Daylight	-7 hours	5 am
PST - Pacific Standard ADT - Alaskan Daylight	-8 hours	4 am

ALA - Alaskan Standard	-9 hours	3 am
HAW - Hawaiian Standard	-10 hours	2 am
Nome, Alaska	-11 hours	1 am
CET - Central European FWT - French Winter MET - Middle European MEWT - Middle European Winter SWT - Swedish Winter	+1 hour	1 pm
EET - Eastern European, USSR Zone 1	+2 hours	2 pm
BT - Baghdad, USSR Zone 2	+3 hours	3 pm
ZP4 - USSR Zone 3	+4 hours	4 pm
ZP5 - USSR Zone 4	+5 hours	5 pm
ZP6 - USSR Zone 5	+6 hours	6 pm
WAST - West Australian Standard	+7 hours	7 pm
CCT - China Coast, USSR Zone 7	+8 hours	8 pm
JST - Japan Standard, USSR Zone 8	+9 hours	9 pm
EAST - East Australian Standard GST Guam Standard, USSR Zone 9	+10 hours	10 pm
IDLE - International Date Line NZST - New Zealand Standard NZT - New Zealand	+12 hours	Midnight

- **SNTP Sever IP:** Set the SNTP server IP address.
- **Switch Timer:** Displays the current time of the switch.
- **Daylight Saving Period:** Set up the Daylight Saving beginning time and Daylight Saving ending time. Both will be different in every year.
- **Daylight Saving Offset (mins):** For non-US and European countries, specify the amount of time for day light savings.
- **Synchronization Interval (secs):** The Synchronization Interval is used for sending synchronizing packets periodically. Users can assign in the range of 64s to 1024s. The default setting of values is "0" which means that you disable the auto synchronizes feature in the SNTP client mode. You can enable the feature when filling the interval range between 64s and 1024s.
- Click  to have the configuration take effect.

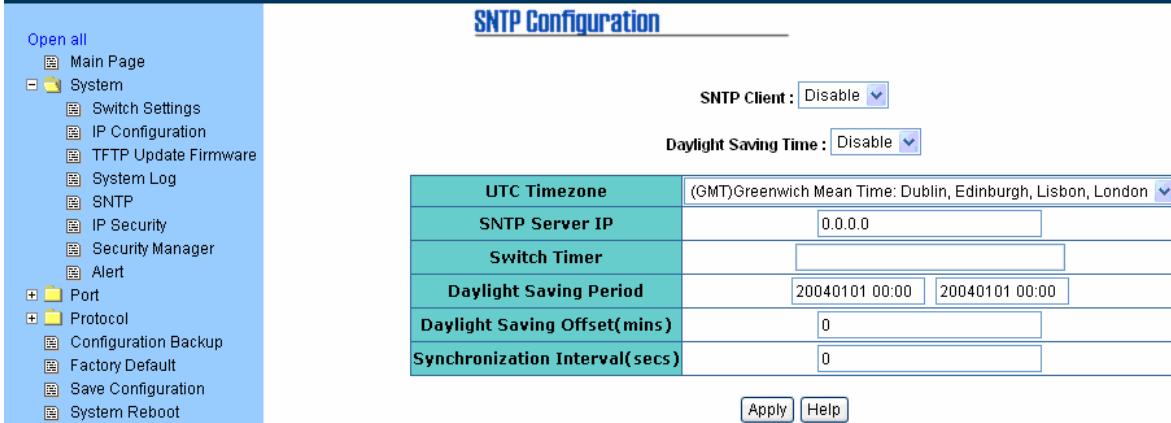

Figure 3.9: SNTP Configuration

### IP Security

The IP security function allows the user to assign 10 specific IP addresses that have permission to access the switch through the web browser for securing switch management.

- **IP Security Mode:** Tick this check box to enable IP security.
- **Security IP 1 ~ 10:** The system allows the user to assign up to 10 specific IP addresses for access security. Only these 10 IP addresses can access and manage the switch through the HTTP service.
- And then, click **Apply** to have the configuration take effect.

*Note* Remember to click the **Save** button of the **Save Configuration** page, otherwise the new configuration will lose when switch powers off.

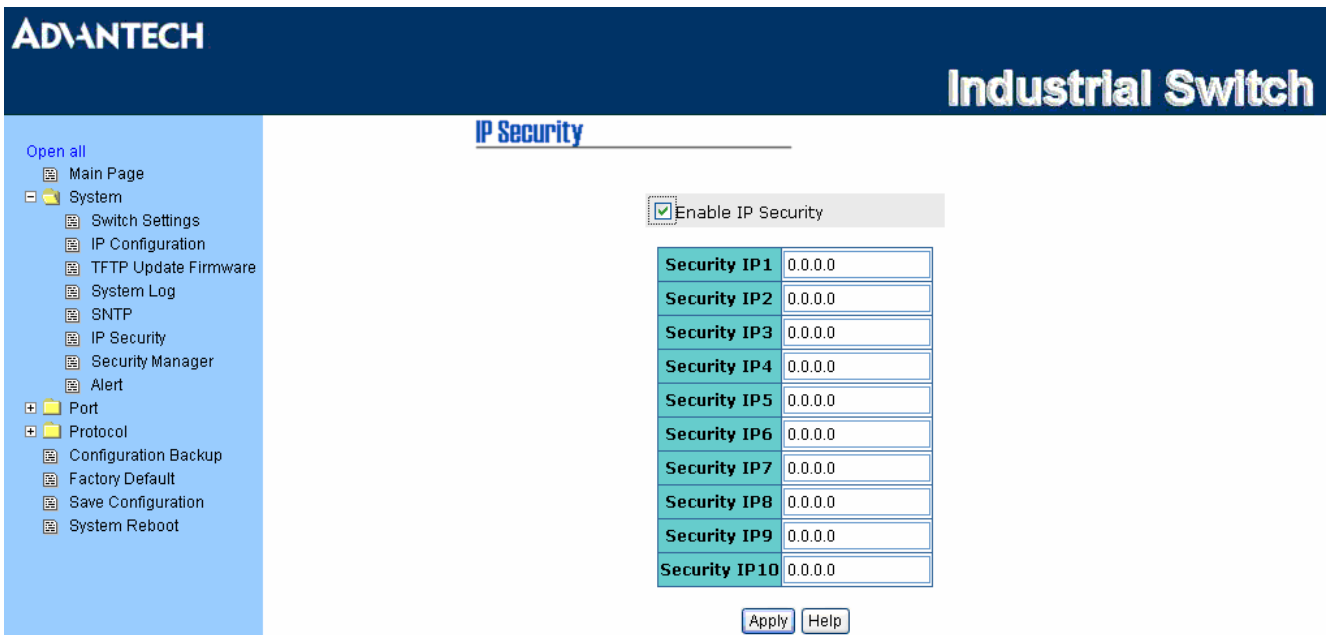

Figure 3.10: IP Security

## Security Manager

Change web management login user name and password for the management security issue.

- **User Name:** Key in the new user name (The default is “admin”).
- **New Password:** Key in the new password (The default is “admin”).
- **Confirm Password:** Re-type the new password for confirmation.
- And then, click **Apply** to have the configuration take effect.

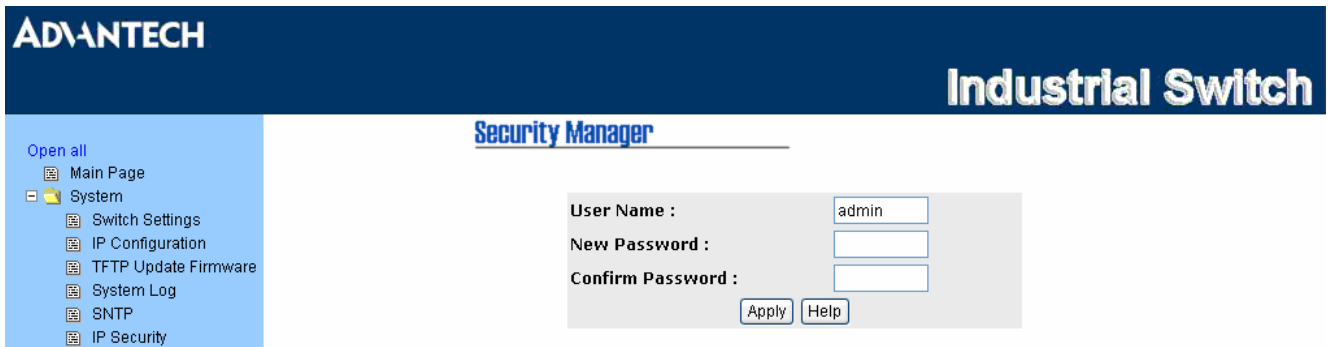

Figure 3.11: Security Manager

## Alert – Email Alert Configuration

When the specific event occurs, the system will send the alert to the email account assigned by users. Users can assign the mail server IP, email account, and forwarded email account for receiving the event alert.

- **Email Alert:** Enable or disable the email alert function.
- **SMTP Server IP Address:** Assign the mail server IP address.
- **Authentication:** Tick the check box to enable and configure the email account/password for authentication.
  - **Mail Account:** Assign the email account to receive the alert. Ex: [johnadmin](#). The email account, which users had assigned in the **SMTP Server IP Address** column, must exist on the mail server.
  - **Password:** Type the password to the email account.
  - **Confirm Password:** Re-confirm the password.
- **E-mail of Recipient 1 ~ 4:** Assign up to 4 email accounts to receive the alert.
- And then, click **Apply** to have the configuration take effect.

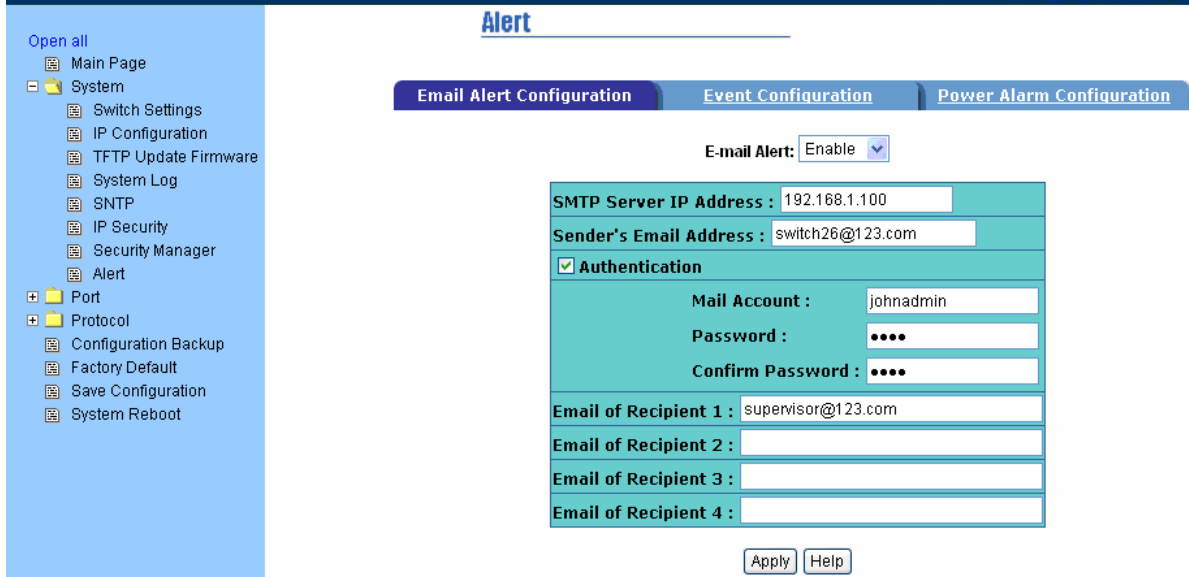

Figure 3.12: Email Alert Configuration

### Alert – Event Configuration

The selected events that occur will cause the system to send out alerts to the assigned SMTP server. Also, users can select port events for alerting.

- **System event selection:** 4 selections – Device cold start, Power status, SNMP Authentication Failure, and X-Ring topology changes. Tick the check box to select the event. When selected events occur, the system will send out the alert.
- **Port event selection:** Select the port events for each port that has 3 selections – Link UP, Link Down, and Link UP & Link Down. Disable means no event is selected.
  - **Link UP:** The system will send out an alert when port connection is up.
  - **Link Down:** The system will send out an alert message when port connection is down.
  - **Link UP & Link Down:** The system will send out an alert message when port connection is up and down.
- After selecting, click **Apply** to have the configuration take effect.

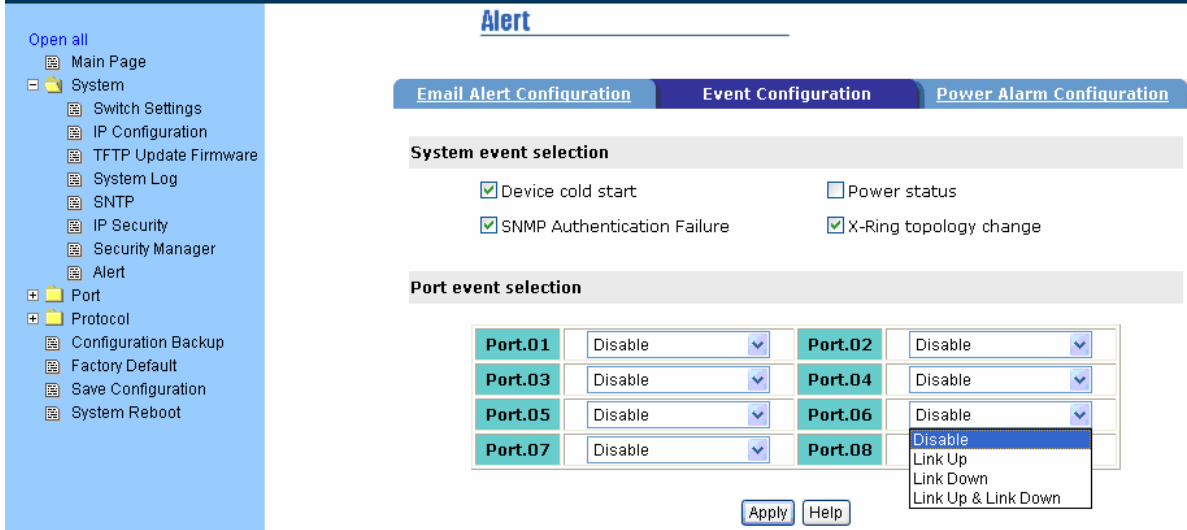

Figure 3.13: Event Configuration

### Alert – Power Alarm Configuration

The power alarm configuration enables the Relay alarm.

- Tick the check box and click **Apply** to have the configuration take effect.

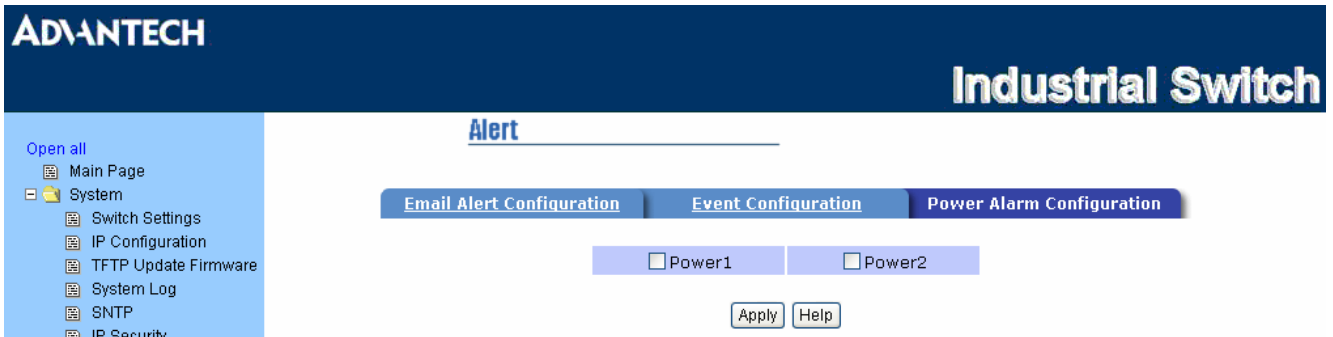

Figure 3.14: Power Alarm Configuration

### 3.1.2 Port

Port setting includes Port Status, Port Statistics, Port Control, Port Mirroring, and Rate Control. Through this interface, users can set the parameters and control the packet flow among the ports.

#### Port Status

Displays port status depending on user's setting and the negotiation result.

- **Port:** Displays the port number.
- **Type:** Displays the media type of the port.
- **Link:** The status of linking—'Up' or 'Down'.
- **State:** The state of the port can be set to 'Enable' or 'Disable' by users via the **Port Control** section. When the state is disabled, the port will not transmit or receive any packet.
- **Negotiation:** Displays the current negotiation mode: **Auto** or **Force**.
- **Speed Duplex:** Displays port connection speed and duplex mode. "**Config**" means the speed and duplex mode are configured by users. "**Actual**" means the current status of the port.
- **Flow Control:** Displays the flow control status including "**Symmetric**", "**Asymmetric**" or "**Disable**" in full mode. "**Config**" means the value is configured by users. "**Actual**" means that the value is the current status of the port.

The screenshot shows the 'Port Status' page of an AD-ANTECH Industrial Switch. The interface includes a navigation menu on the left with options like 'Main Page', 'System', 'Port', 'Protocol', and 'Configuration Backup'. The main content area displays a table with the following data:

Port	Type	Link	State	Negotiation	Speed Duplex		Flow Control	
					Config	Actual	Config	Actual
Port.01	100TX	Down	Enable	Auto	100 Full	N/A	Disable	N/A
Port.02	100TX	Down	Enable	Auto	100 Full	N/A	Disable	N/A
Port.03	100TX	Up	Enable	Auto	100 Full	100 Full	Disable	Disable
Port.04	100TX	Down	Enable	Auto	100 Full	N/A	Disable	N/A
Port.05	100TX	Down	Enable	Auto	100 Full	N/A	Disable	N/A
Port.06	100TX	Down	Enable	Auto	100 Full	N/A	Disable	N/A
Port.07	100FX	Down	Enable	Force	100 Full	N/A	Disable	N/A
Port.08	100FX	Down	Enable	Force	100 Full	N/A	Disable	N/A

Figure 3.15: Port Status

#### Port Statistics

The following information provides the current port statistics.

- **Port:** Displays the port number.
- **Type:** Displays the media type of the port.
- **Link:** The status of linking—'Up' or 'Down'.
- **State:** The user can set the state of the port to 'Enable' or 'Disable' via the **Port Control** section. When the state is disabled, the port will not transmit or receive any packet.
- **Tx Good Packet:** The counts of transmitting good packets via this port.
- **Tx Bad Packet:** The counts of transmitting bad packets (including undersize [less than 64 bytes], oversize, CRC Align errors, fragments and jabbers packets) via this port.
- **Rx Good Packet:** The counts of receiving good packets via this port.
- **Rx Bad Packet:** The counts of receiving bad packets (including undersize [less than 64 bytes], oversize, CRC error, fragments and jabbers) via this port.
- **Tx Abort Packet:** The aborted packet while transmitting.
- **Packet Collision:** The counts of collision packet.

- **CRC Error:** The counts of cyclic redundancy check errors.
- **Fragments:** The counts of non-complete packets.
- Click  to clean all counts.

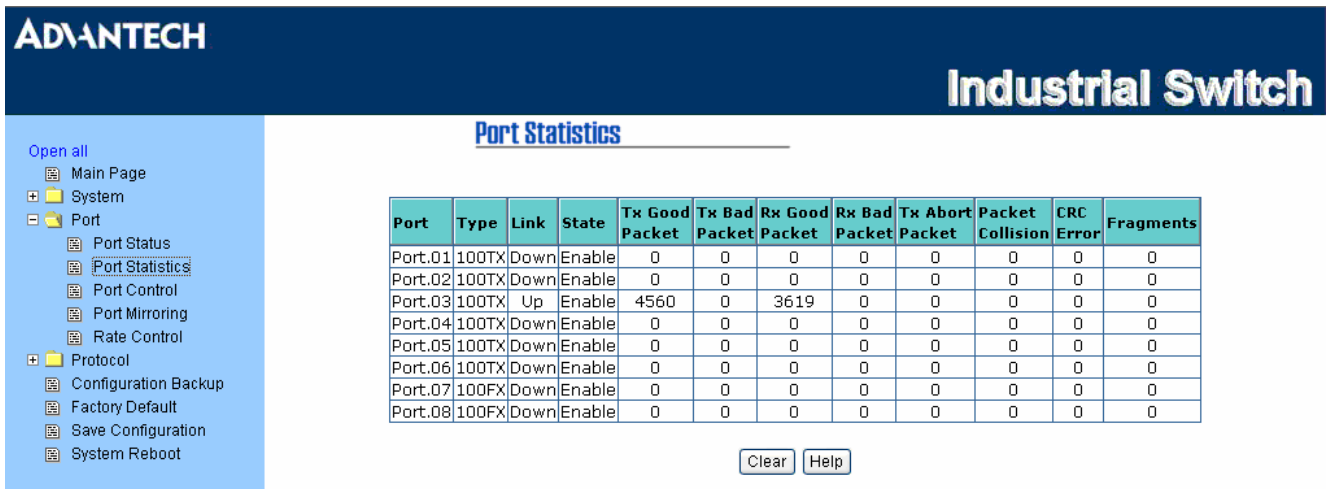

Figure 3.16: Port Statistics

## Port Control

In Port Control, you can select ports and click the pull-down menus to set parameters of each port to control the transmitting/receiving packets.

- **Port:** Select the port that you want to configure.
- **State:** Current port status. The port can be set to Disable or Enable mode. When disabled, it will not receive or transmit any packet.
- **Negotiation:** Auto and Force. Being set to Auto, the speed and duplex mode are negotiated automatically. When you set it to Force, you have to assign the speed and duplex mode manually.
- **Speed:** It is available for selecting when the Negotiation column is set to Force. When the Negotiation column is set to Auto, this column is read only.
- **Duplex:** It is available for selecting when the Negotiation column is set to Force. When the Negotiation column is set to Auto, this column is read only.
- **Flow Control:** Set flow control function to **Symmetric** or **Asymmetric** in Full Duplex mode.
- Click  to have the configuration take effect.



Open all

- 🏠 Main Page
- 📁 System
  - 📁 Port
    - 🏠 Port Status
    - 🏠 Port Statistics
    - 🏠 Port Control
    - 🏠 Port Mirroring
    - 🏠 Rate Control
  - 📁 Protocol
    - 🏠 Configuration Backup
    - 🏠 Factory Default
    - 🏠 Save Configuration
    - 🏠 System Reboot

### Port Control

Port	State	Negotiation	Speed	Duplex	Flow Control
Port.04	Enable	Auto	100	Full	Symmetric
Port.05					
Port.06					
Port.07					

Port	Type	Link	State	Negotiation	Speed Duplex		Flow Control	
					Config	Actual	Config	Actual
Port.01	100TX	Down	Enable	Auto	100 Full	N/A	Disable	N/A
Port.02	100TX	Down	Enable	Auto	100 Full	N/A	Disable	N/A
Port.03	100TX	Up	Enable	Auto	100 Full	100 Full	Disable	Disable
Port.04	100TX	Down	Enable	Auto	100 Full	N/A	Disable	N/A
Port.05	100TX	Down	Enable	Auto	100 Full	N/A	Disable	N/A
Port.06	100TX	Down	Enable	Auto	100 Full	N/A	Disable	N/A

Figure 3.17: Port Control

### Port Mirroring

The Port mirroring is a method to monitor traffic in switched networks. Traffic through ports can be monitored by one specific port. That is, traffic goes in or out monitored ports will be duplicated into the mirroring port.

- **Port Mirroring Mode:** Set mirroring mode -- **Disable**, **TX Only**, and **Both**. The default value is “Disable”.
- **Analysis Port:** Select one port to be the mirroring port to see all monitored port traffic. Users can connect the mirroring port to LAN analyzer or Netxray.
- **Monitor Port:** The ports users want to monitor. All monitored port traffic will be copied to the mirroring port. Mark the **State** check box to select the port.
- And then click  to have the configuration take effect.

Open all

- 🏠 Main Page
- 📁 System
  - 📁 Port
    - 🏠 Port Status
    - 🏠 Port Statistics
    - 🏠 Port Control
    - 🏠 Port Mirroring
    - 🏠 Rate Control
  - 📁 Protocol
    - 🏠 Configuration Backup
    - 🏠 Factory Default
    - 🏠 Save Configuration
    - 🏠 System Reboot

### Port Mirroring

Port Mirroring Mode : TX&RX Both

Analysis Port : Port.01

Monitor Port	State
Port.01	<input type="checkbox"/>
Port.02	<input type="checkbox"/>
Port.03	<input checked="" type="checkbox"/>
Port.04	<input checked="" type="checkbox"/>
Port.05	<input type="checkbox"/>
Port.06	<input type="checkbox"/>
Port.07	<input type="checkbox"/>
Port.08	<input type="checkbox"/>

Figure 3.18: Port Mirroring

**Note**

1. Select *Disable* for the monitor mode item to disable port mirroring.
2. Remember to click the **Save** button of the **Save Configuration** page, otherwise the new configuration will lose when switch powers off.

**Rate Control**

Here you can set up every port's packet limitation type and bandwidth rate.

- **Limit Packet Type:** Select the packet type you want to filter. The packet types have 4 options for selecting: **All**, **Broadcast/Multicast/Unknown Unicast**, **Broadcast/Multicast**, and **Broadcast only**. The four packet type options are for ingress frames limitation. The egress rate only supports 'All' type.
- **Ingress:** Click the pull-down menu to select the port effective ingress rate (The default value is "Disable")
- **Egress for All:** Click the pull-down menu to select the port effective egress rate (The default value is "Disable")
- And then, click **Apply** to make the settings take effect.

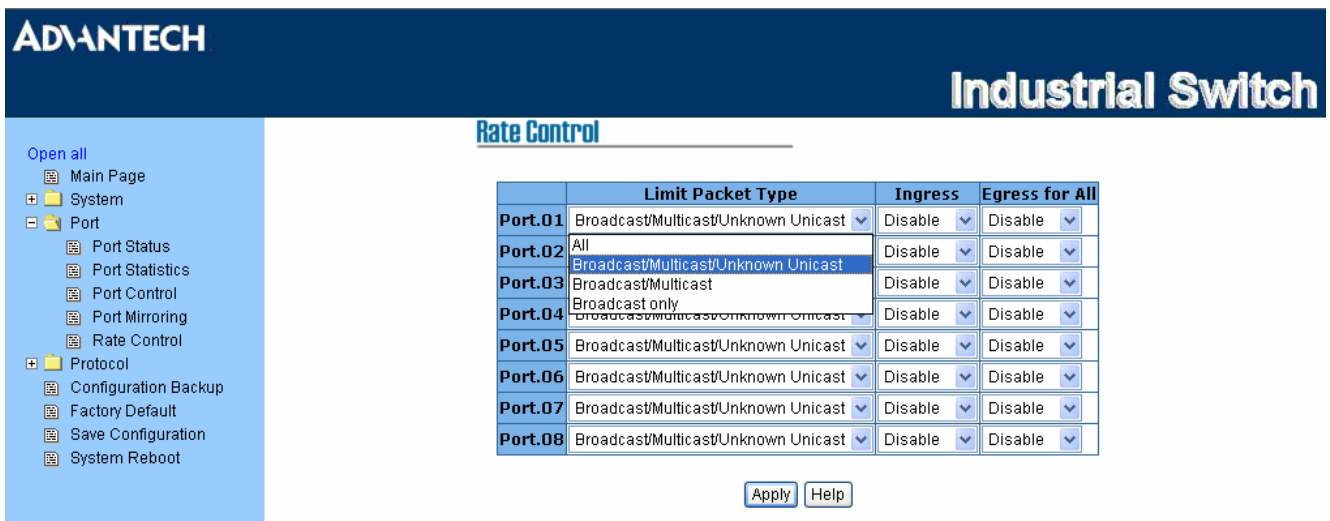

Figure 3.19: Rate Control

### 3.1.3 Protocol

The user can configure the layer 2 protocol setting via this interface.

#### VLAN configuration

A Virtual LAN (VLAN) is a logical network grouping that limits the broadcast domain, which would allow you to isolate network traffic, so only the members of the same VLAN will receive traffic from the others of the same VLAN. Basically, creating a VLAN on the switch is logically equivalent of reconnecting a group of network devices to another Layer 2 switch. However, all the network devices are still plugged into the same switch physically.

The switch supports **Port-based** and **802.1Q** (tagged-based) VLAN. The default configuration of VLAN operation mode is “**Disable**”.

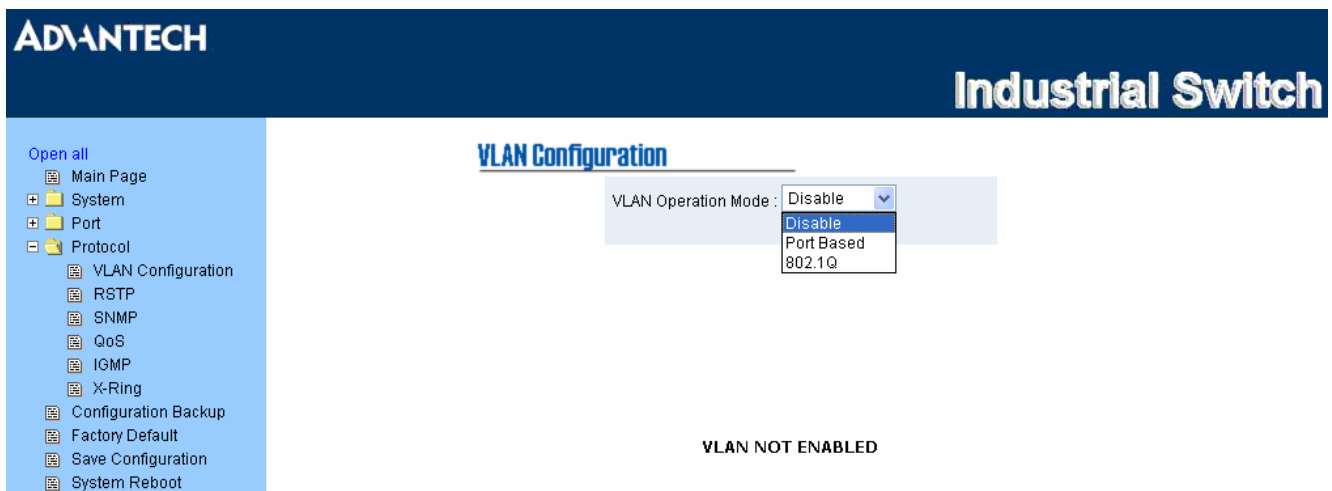

Figure 3.20: VLAN Configuration

#### VLAN configuration - Port-based VLAN

Packets can go among only members of the same VLAN group. Note all unselected ports are treated as belonging to another single VLAN. If the port-based VLAN enabled, the VLAN-tagging is ignored.

In order for an end station to send packets to different VLAN groups, it itself has to be either capable of tagging packets it sends with VLAN tags or attached to a VLAN-aware bridge that is capable of classifying and tagging the packet with different VLAN ID based on not only default PVID but also other information about the packet, such as the protocol.

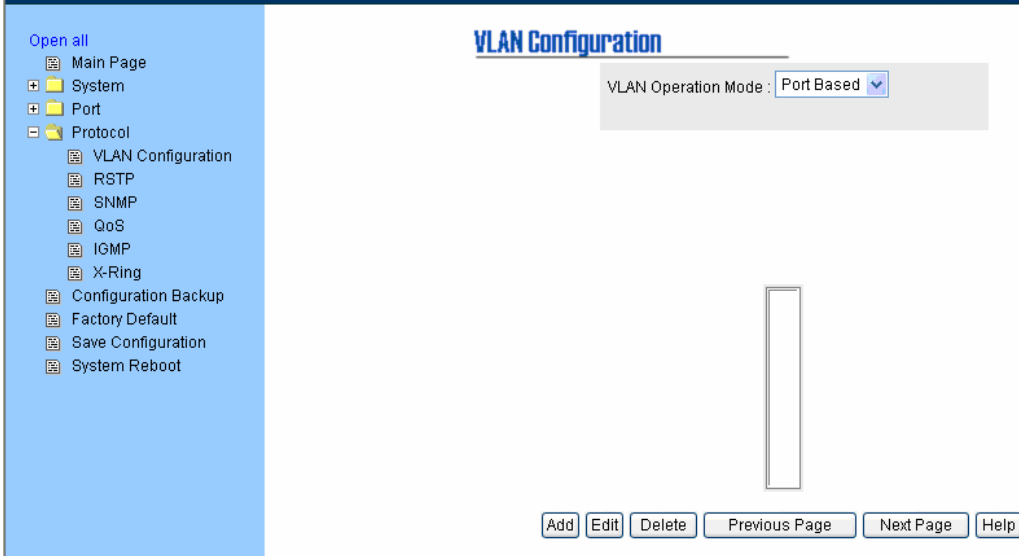

Figure 3.21: Port-based Mode

- Pull down the selection item and focus on **Port Based** then click **Apply** to set the VLAN Operation Mode to **Port Based**.
- Click **Add** to add a new VLAN group.

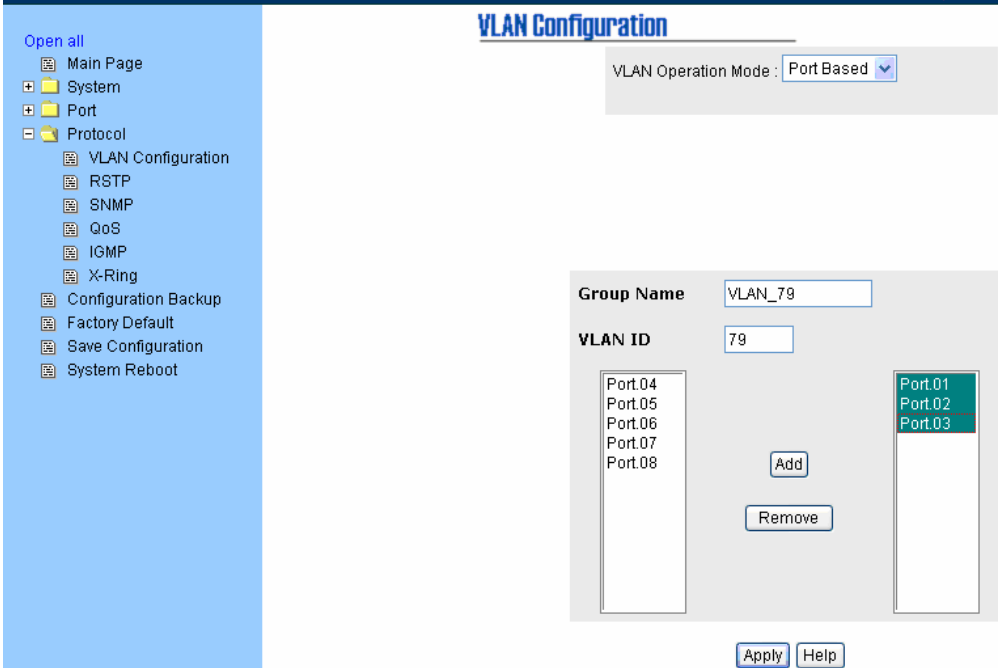

Figure 3.22: Port-based Mode--Add

- Enter Group Name and VLAN ID. Having selected the port numbers, click Add to add the ports to the right field to group these members into a VLAN group or remove any of them listed in the right field from the VLAN.

- And then, click **Apply** to have the settings take effect.
- You will see the VLAN displays.

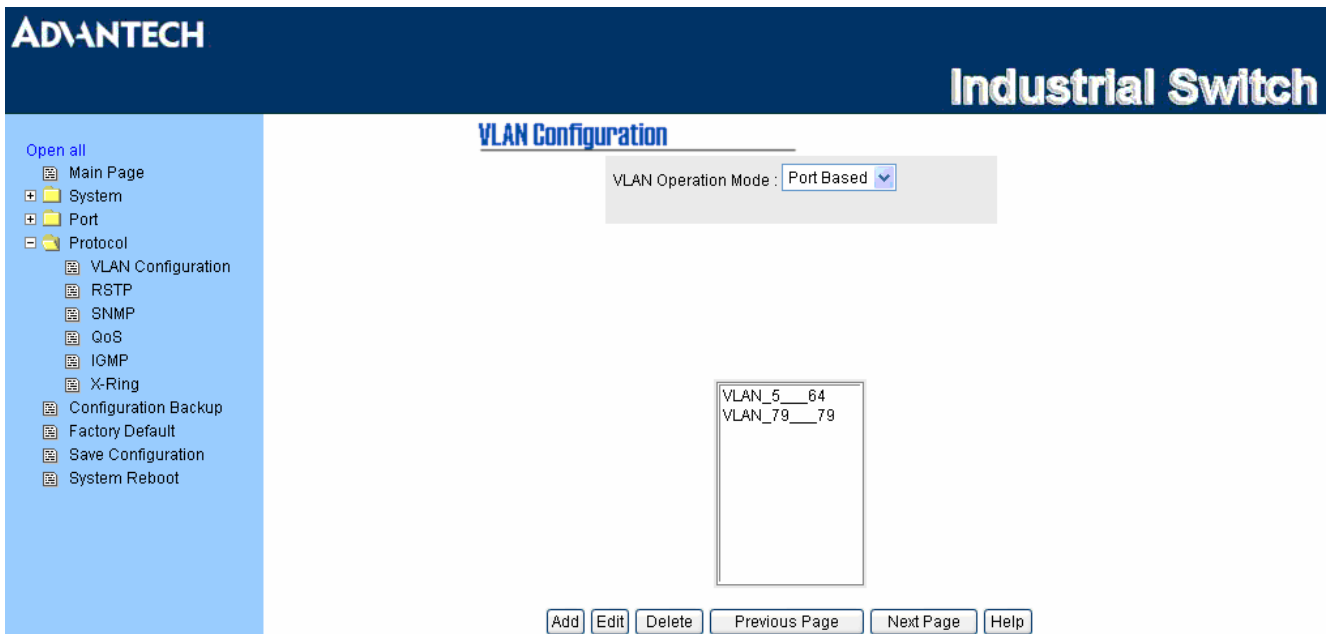

Figure 3.23: Port-based Edit/Delete

- Select the VLAN group name and click **Delete** to delete the VLAN.
- Select the VLAN group name and click **Edit** to modify group name, VLAN ID, or add/remove the members of the existing VLAN group.

*Note* Remember to click the **Save** button of the **Save Configuration** page, otherwise the new configuration will lose when switch powers off.

### 802.1Q VLAN

Tagged-based VLAN is an IEEE 802.1Q specification standard. Therefore, it is possible to create a VLAN across devices from different switch vendors. IEEE 802.1Q VLAN uses a technique to insert a “tag” into the Ethernet frames. The tag contains a VLAN Identifier (VID) that indicates the VLAN numbers. You can create a Tag-based VLAN, and enable/disable the GVRP protocol. Up to 256 VLAN groups are provided for configuring. With 802.1Q VLAN enabled, all ports on the switch belong to default VLAN of VID 1. The default VLAN can’t be deleted.

GVRP (GARP VLAN Registration Protocol) is a protocol that facilitates control of virtual local area networks (VLANs) within a larger network. GVRP conforms to the IEEE 802.1Q specification, which defines a method of tagging frames with VLAN configuration data. This allows network devices to dynamically exchange VLAN configuration information with other devices.

GVRP based on GARP (Generic Attribute Registration Protocol) is a protocol that defines procedures by which end stations and switches in a local area network (LAN) can register and de-register attributes, such as identifiers or addresses, with each other.

Every end station and switch thus has a current record of all the other end stations and switches that can be reached.

## 802.1Q Configuration - Basic

- Pull down the selection item and focus on **802.1Q** then click **Apply** to set the VLAN Operation Mode to **802.1Q**.
- **Management VLAN ID:** The default “0” in the column field means the VLAN function in 802.1Q mode is not available. Ticking the check box and filling the VLAN ID column with a value from 1 to 4094, the member ports of this VLAN can then access the management interface.
- Click **Apply** to have the settings take effect.

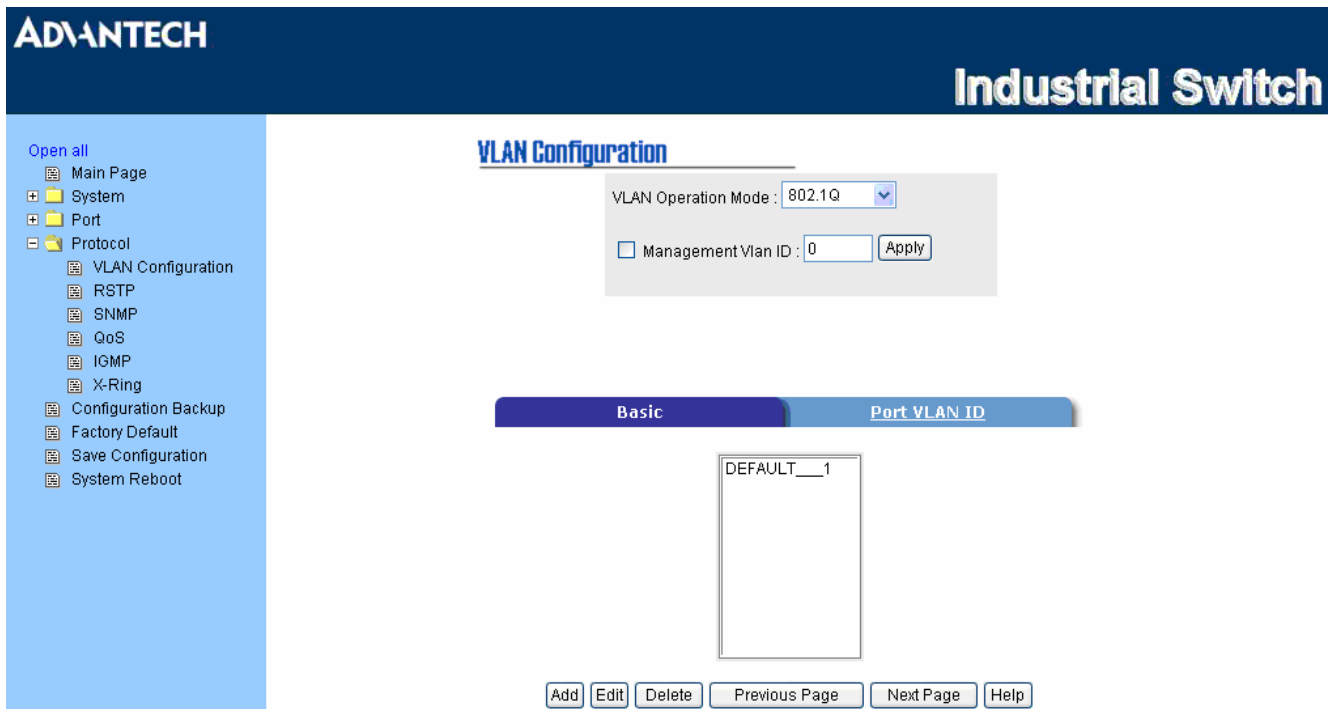

Figure 3.24: 802.1Q VLAN Configuration

### Add

Add an 802.1Q-based VLAN group.

- **Group Name:** Specify the group name for the VLAN.
- **VLAN ID:** Please enter the VLAN ID in the range of 2 to 4094.
- Select ports and click the Add button to add them to the right field.
- Click **Next**.
- Click the pull-down menu to select Tag/Untag for each VLAN member. Setting the port to Tag means that the outgoing frames are tagged with VLAN ID. While setting the port to Untag means that the outgoing frames are not tagged with VLAN ID.
- Click **Apply** to have the configuration take effect.

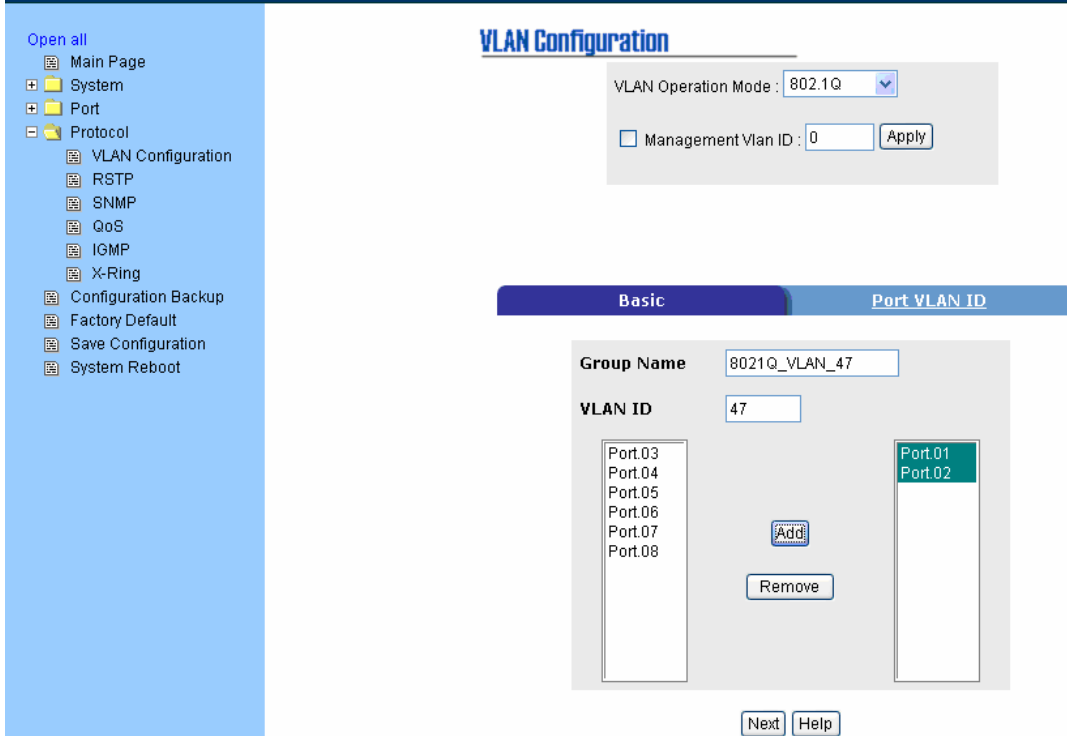

Figure 3.25: Adding an 802.1Q VLAN

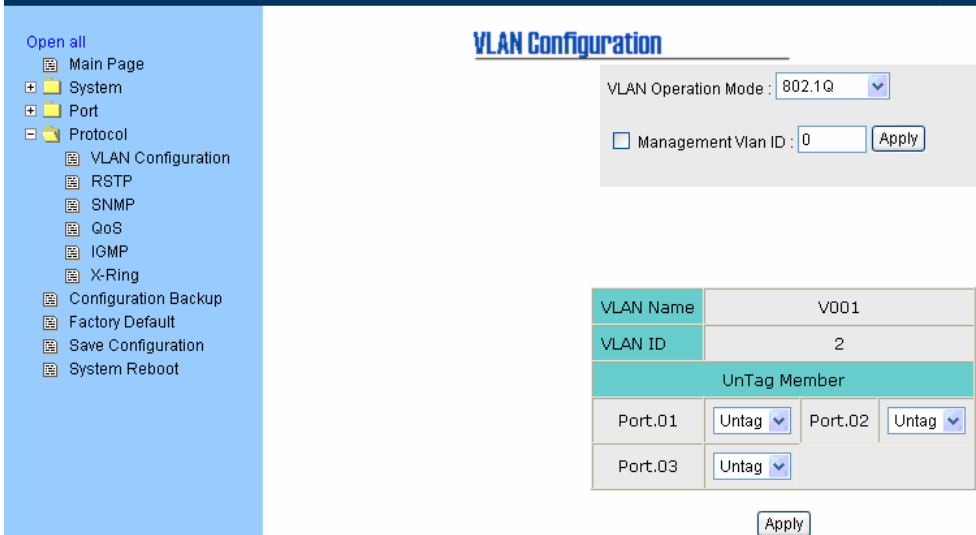

Figure 3.26: Tag/Untag Member Ports

**Edit/Delete**

Modify or delete the existed VLAN groups.

- Select an existed VLAN group from the list.
- Click **Edit** to modify Group Name, VLAN ID or change the members of the VLAN.

- Or click **Delete** to delete the VLAN.

### 802.1Q Configuration – Port VLAN ID

Assign the Port VLAN ID for the selected ports.

- **Port:** Select ports to be assigned a Port VLAN ID.
- **Port VLAN ID:** Enter the Port VLAN ID in the range between 1 and 4094.
- Click **Apply** to have the settings take effect.

The screenshot shows the 'VLAN Configuration' page in the ADVANTECH Industrial Switch web interface. The 'Port VLAN ID' tab is selected. At the top, 'VLAN Operation Mode' is set to '802.1Q'. Below that, there is a checkbox for 'Management Vlan ID' with a value of '0' and an 'Apply' button. The main configuration area has two tabs: 'Basic' and 'Port VLAN ID'. Under the 'Port VLAN ID' tab, there is a table with two columns: 'Port' and 'Port VLAN ID'. The 'Port' column contains a list of ports: Port.01, Port.02 (highlighted), Port.03, and Port.04. The 'Port VLAN ID' column contains an input field with the value '1'. Below the table are 'Apply' and 'Help' buttons. At the bottom of the page, there is a summary table:

Port	VLAN ID
Port.02	1

Figure 3.27: Port VLAN ID Setting

### Rapid Spanning Tree

The Rapid Spanning Tree Protocol (RSTP) is an evolution of the Spanning Tree Protocol and provides for faster spanning tree convergence after a topology change. The system also supports STP and the system will auto-detect the connected device that is running STP or RSTP protocol.

#### RSTP - System Configuration

- The user can view spanning tree information of the Root Bridge.
- The user can modify RSTP state. After modification, click **Apply** button.
  - **RSTP mode:** The user must enable the RSTP function first before configuring the related parameters.
  - **Priority (0-61440):** The switch with the lowest value has the highest priority and is selected as the root. If the value is changed, the user must reboot the switch. The value must be a multiple of 4096 according to the protocol standard rule.



- **Max Age (6-40):** The number of seconds a switch waits without receiving Spanning-tree Protocol configuration messages before attempting a reconfiguration. Enter a value between 6 through 40.
- **Hello Time (1-10):** The time that controls the switch to send out the BPDU packet to check RSTP current status. Enter a value between 1 through 10.
- **Forward Delay Time (4-30):** The number of seconds a port waits before changing from its Rapid Spanning-Tree Protocol learning and listening states to the forwarding state. Enter a value between 4 through 30.

Note

Follow the rule to configure the MAX Age, Hello Time, and Forward Delay Time.

$2 \times (\text{Forward Delay Time value} - 1) \geq \text{Max Age value} \geq 2 \times (\text{Hello Time value} + 1)$

Figure 3.28: RSTP System Configuration

### RSTP - Port Configuration

Here you can configure the path cost and priority of each port.

- Select the port in the port column field.
- **Path Cost:** The cost of the path to the other bridge from this transmitting bridge at the specified port. Enter a number between 1 and 200,000,000.
- **Priority:** Decide which port should be blocked by priority in LAN. Enter a number between 0 and 240 (the port of the highest value will be blocked). The value of priority must be the multiple of 16.
- **Admin P2P:** Some of the rapid state transactions that are possible within RSTP depend upon whether the port concerned can only be connected to exactly one other bridge (i.e. it is served by a point-to-point LAN segment), or can be connected to two or more bridges (i.e. it is served by a shared medium LAN segment). This function allows the P2P status of the link to be manipulated administratively. True means P2P enabled. False means P2P disabled.
- **Admin Edge:** The port directly connected to end stations won't create bridging loop in the network. To configure the port as an edge port, set the port to "True" status.
- **Admin Non Stp:** The port includes the STP mathematic calculation. True is not including STP mathematic calculation. False is including the STP mathematic calculation.

- Click **Apply** to have the configuration take effect.

Port	Path Cost (1-200000000)	Priority (0-240)	Admin P2P	Admin Edge	Admin Non Stp
Port.01					
Port.02	200000	128	Auto	True	False
Port.03					
Port.04					
Port.05					

priority must be a multiple of 16

Apply Help

Port	Path Cost	Port Priority	Admin P2P	Admin Edge	Stp Neighbor	State	Role
Port.01	2000000	128	True	True	False	Disabled	Disabled
Port.02	2000000	128	True	True	False	Disabled	Disabled
Port.03	2000000	128	True	True	False	Disabled	Disabled
Port.04	2000000	128	True	True	False	Disabled	Disabled
Port.05	2000000	128	True	True	False	Forwarding	Designated
Port.06	2000000	128	True	True	False	Disabled	Disabled
Port.07	2000000	128	True	True	False	Disabled	Disabled
Port.08	2000000	128	True	True	False	Disabled	Disabled

Figure 3.29: RSTP Port Configuration

## SNMP Configuration

Simple Network Management Protocol (SNMP) is the protocol developed to manage nodes (servers, workstations, routers, switches and hubs etc.) on an IP network. SNMP enables network administrators to manage network performance, find and solve network problems, and plan for network growth. Network management systems learn of problems by receiving traps or change notices from network devices implementing SNMP.

## System Configuration

### Community Strings

Here you can define the new community string set and remove the unwanted community string.

- **String:** Fill the name string.
- **RO:** Read only. Enables requests accompanied by this community string to display MIB-object information.
- **RW:** Read write. Enables requests accompanied by this community string to display MIB-object information and to set MIB objects.
- Click **Add**.
- To remove the community string, select the community string that you have defined and click **Remove**. You cannot edit the name of the default community string set.

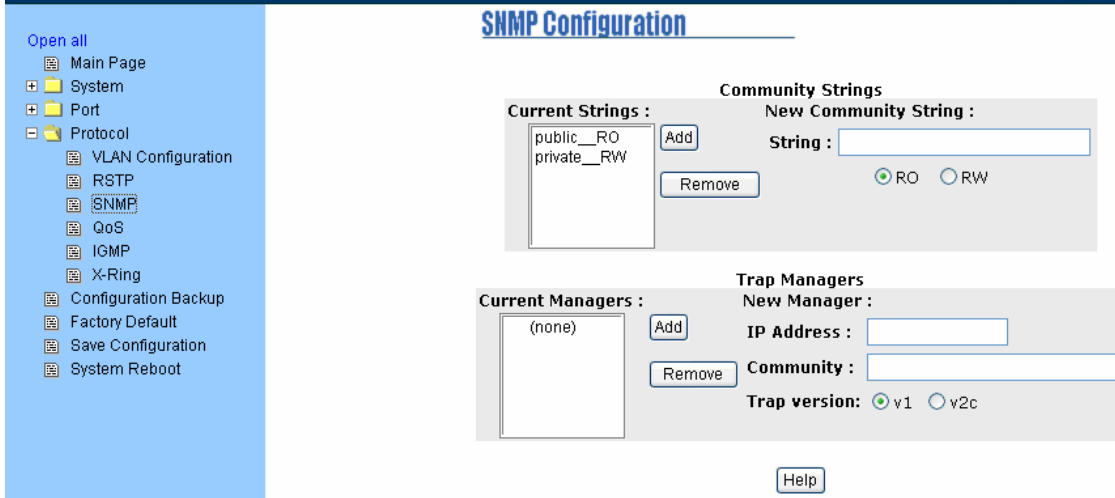

Figure 3.30: SNMP Configuration

### Trap Managers

A trap manager is a management station that receives the trap messages generated by the switch. If no trap manager is defined, no traps will be issued. Create a trap manager by entering the IP address of the station and a community string. To define a management station as a trap manager, assign an IP address, enter the SNMP community strings, and select the SNMP trap version.

- **IP Address:** Enter the IP address of the trap manager.
- **Community:** Enter the community string.
- **Trap Version:** Select the SNMP trap version type—v1 or v2c.
- Click **Add**.
- To remove the community string, select the community string listed in the current managers field and click **Remove**.

## QoS Configuration

Here you can configure QoS policy and priority setting, port priority setting, COS and TOS setting.

### QoS Policy

- **QoS Policy:** Select the QoS policy rule.
  - **Use an 8,4,2,1 weighted fair queuing scheme:** The switch will follow 8:4:2:1 rate to process priority queue from High to lowest queue. For example, while the system processes, 1 frame of the lowest queue, 2 frames of the low queue, 4 frames of the middle queue, and 8 frames of the high queue will be processed at the same time in accordance with the 8,4,2,1 policy rule.
  - **Use a strict priority scheme:** Always the higher queue will be processed first, except the higher queue is empty.
  - **Priority Type:** There are 5 priority type selections available—**Port-based**, **TOS only**, **COS only**, **TOS first**, and **COS first**. Disable means no priority type is selected.
- Click  button to make the settings effective.

### Priority Type

- There are 5 priority type options available—**Port-based**, **TOS only**, **COS only**, **TOS first**, and **COS first**.
- Click  to have the settings taken effect.

### Default Port Priority

- There are four options for port priority—**High**, **Middle**, **Low**, and **Lowest**.
- Click  to have the settings taken effect.

### COS Configuration

Set up the COS priority level.

- **Priority:** Set up the COS priority level 0~7—High, Middle, Low, Lowest.
- Click .

### TOS Configuration

Set up the TOS priority.

- **Priority:** The system provides 0~63 TOS priority level. Each level has 4 types of priority—High, Middle, Low, and Lowest. The default value is 'Lowest' priority for each level. When the IP packet is received, the system will check the TOS level value in the IP packet that has received. For example, the user sets the TOS level 25 as high, the system will check the TOS value of the received IP packet. If the TOS value of received IP packet is 25 (priority = high), and then the packet priority will have highest priority.
- Click  to make the settings take effect.

- Open all
- [-] Main Page
- [-] System
- [-] Port
- [-] Protocol
  - [-] VLAN Configuration
  - [-] RSTP
  - [-] SNMP
  - [-] QoS
  - [-] IGMP
  - [-] X-Ring
- [-] Configuration Backup
- [-] Factory Default
- [-] Save Configuration
- [-] System Reboot

QoS

**QoS Policy**

Use an 8,4,2,1 weighted fair queuing scheme

Use a strict priority scheme

Priority Type:

Port.01	Port.02	Port.03	Port.04	Port.05	Port.06	Port.07	Port.08
Port-based ▾	Port-based ▾	Port-based ▾	Port-based ▾	Port-based ▾	Port-based ▾	Port-based ▾	Port-based ▾

Default Port Priority:

Port.01	Port.02	Port.03	Port.04	Port.05	Port.06	Port.07	Port.08
Lowest ▾	Lowest ▾	Lowest ▾	Lowest ▾	Lowest ▾	Lowest ▾	Lowest ▾	Lowest ▾

Apply Help

COS

Priority	0	1	2	3	4	5	6	7
	Lowest ▾	Lowest ▾	Lowest ▾	Lowest ▾	Lowest ▾	Lowest ▾	Lowest ▾	Lowest ▾

Apply Help

TOS

Priority	0	1	2	3	4	5	6	7
	Lowest ▾	Lowest ▾	Lowest ▾	Lowest ▾	Lowest ▾	Lowest ▾	Lowest ▾	Lowest ▾
Priority	8	9	10	11	12	13	14	15
	Lowest ▾	Lowest ▾	Lowest ▾	Lowest ▾	Lowest ▾	Lowest ▾	Lowest ▾	Lowest ▾
Priority	16	17	18	19	20	21	22	23
	Lowest ▾	Lowest ▾	Lowest ▾	Lowest ▾	Lowest ▾	Lowest ▾	Lowest ▾	Lowest ▾
Priority	24	25	26	27	28	29	30	31
	Lowest ▾	Lowest ▾	Lowest ▾	Lowest ▾	Lowest ▾	Lowest ▾	Lowest ▾	Lowest ▾
Priority	32	33	34	35	36	37	38	39
	Lowest ▾	Lowest ▾	Lowest ▾	Lowest ▾	Lowest ▾	Lowest ▾	Lowest ▾	Lowest ▾
Priority	40	41	42	43	44	45	46	47
	Lowest ▾	Lowest ▾	Lowest ▾	Lowest ▾	Lowest ▾	Lowest ▾	Lowest ▾	Lowest ▾
Priority	48	49	50	51	52	53	54	55
	Lowest ▾	Lowest ▾	Lowest ▾	Lowest ▾	Lowest ▾	Lowest ▾	Lowest ▾	Lowest ▾
Priority	56	57	58	59	60	61	62	63
	Lowest ▾	Lowest ▾	Lowest ▾	Lowest ▾	Lowest ▾	Lowest ▾	Lowest ▾	Lowest ▾

Apply Help

Figure 3.31: QoS Configuration

**IGMP Configuration**

The Internet Group Management Protocol (IGMP) is an internal protocol of the Internet Protocol (IP) suite. IP manages multicast traffic by using switches, routers, and hosts that support IGMP. Enabling IGMP allows the ports to detect IGMP queries, report packets, and manage IP multicast traffic through the switch. IGMP have three fundamental types of message shown as follows:

Message	Description

<b>Query</b>	A message sent from the querier (IGMP router or switch) asking for a response from each host belonging to the multicast group.
<b>Report</b>	A message sent by a host to the querier to indicate that the host wants to be or is a member of a given group indicated in the report message.
<b>Leave Group</b>	A message sent by a host to the querier to indicate that the host has quit being a member of a specific multicast group.

The switch supports IP multicast. You can enable IGMP protocol via setting the IGMP Configuration page to see the IGMP snooping information. IP multicast addresses are in the range of 224.0.0.0 through 239.255.255.255.

- **IGMP Protocol:** Enable or disable the IGMP protocol.
- **IGMP V2 Query:** Click the pull-down menu to enable/disable the IGMP query function as to set the switch as a querier for IGMP version 2 multicast networks.
- Click **Apply** .

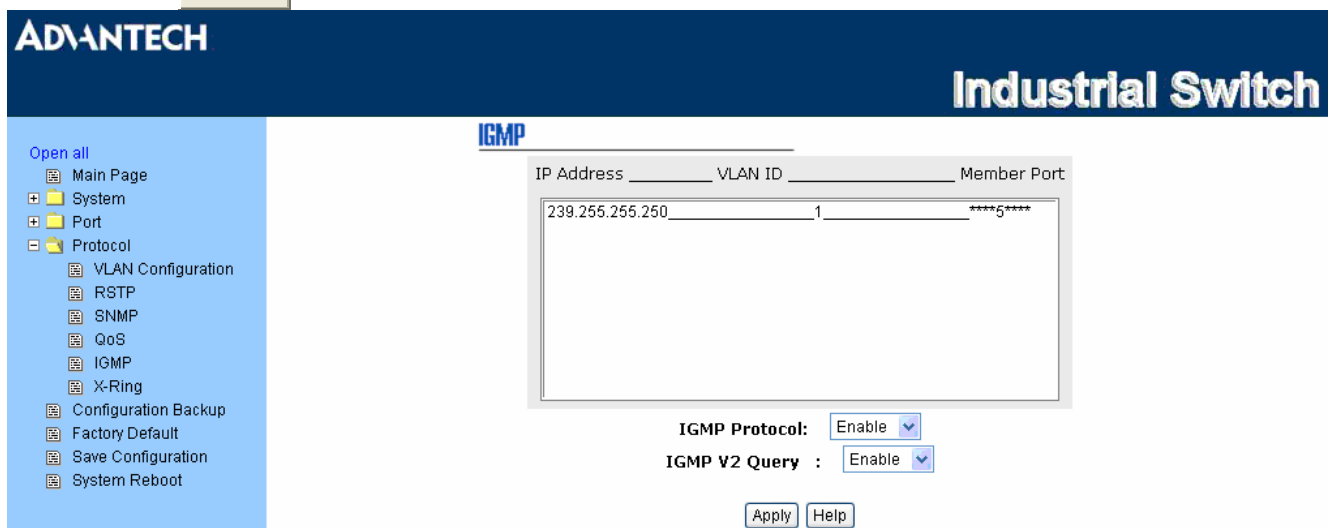

Figure 3.32: IGMP Configuration

## X-Ring

X-Ring provides a faster redundant recovery than Spanning Tree topology. The action is similar to STP or RSTP, but the algorithms between them are not the same.

In the X-Ring topology, every switch should be enabled with X-Ring function and two ports should be assigned as the member ports in the ring. Only one switch in the X-Ring group would be set as the master switch that one of its two member ports would be blocked, called backup port, and the other port is called working port. Other switches in the X-Ring group are called working switches and their two member ports are called working ports. When the failure of network connection occurs, the backup port of the master switch (Ring Master) will automatically become a working port to recover from the failure.

The switch supports the function and interface for setting the switch as the ring master or not. The ring master can negotiate and place command to other switches in the X-Ring group. If there are 2 or more switches in master mode, the software will select the switch with lowest MAC address number as the ring master. The X-Ring master ring mode can be enabled by setting the X-Ring configuration interface. Also, the user can identify whether the switch is the ring master by checking the R.M. LED indicator on the panel of the switch.

The system also supports the **Couple Ring** that can connect 2 or more X-Ring group for the redundant backup function; **Dual Homing** function that can prevent connection lose between X-Ring group and upper level/core switch. Apart from the advantages, **Central Ring** can handle up to 4 rings in the system and has the ability to recover from failure within 20 milliseconds.

- **Enable X-Ring:** To enable the X-Ring function, tick the checkbox beside the **Enable Ring** string label. If this checkbox is not ticked, all the ring functions are unavailable.
  - **1st Ring Port:** Pull down the selection menu to assign a port as the **1st Ring Port** that is the working port.
  - **2nd Ring Port:** Pull down the selection menu to assign a port as the **2nd Ring Port** that is the backup port. When **1st Ring Port** fails, the system will automatically upgrade the **2nd Ring Port** to be the working port.
- **Enable Couple Ring:** To enable the couple ring function, tick the check box beside the **Enable Couple Ring** label.
  - **Coupling Port:** Assign the member port which is connected to the other ring group.
  - **Control Port:** When the **Enable Couple Ring** checkbox is ticked, you have to assign the control port to form a couple-ring group between the two X-rings.
- **Enable Dual Homing:** Set up one of the ports on the switch to be the Dual Homing port. For a switch, there is only one Dual Homing port. Dual Homing function only works when the X-Ring function enabled.
- And then, click Apply to apply the configuration.

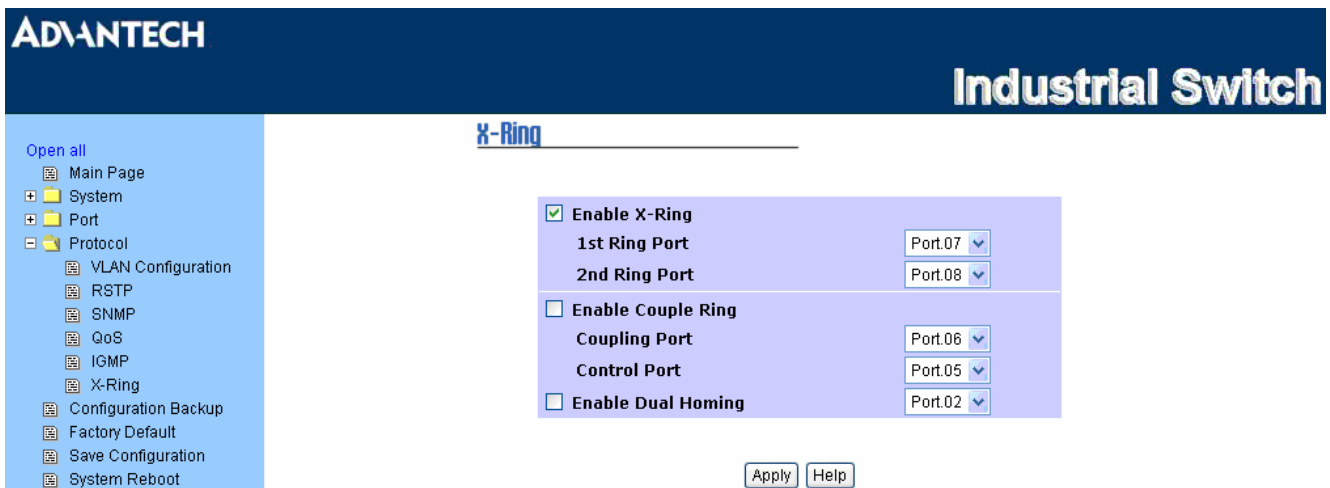

Figure 3.33: X-ring

*Note*

*When the X-Ring function enable, user must disable the RSTP. The X-Ring function and RSTP function cannot exist at the same time. Remember to click the **Save** button of the **Save Configuration** page, otherwise the new configuration will lose when switch powers off.*

### 3.1.4 Configuration Backup

This interface allows users to back up the current configuration on the switch to the TFTP server. Also, users can restore the industrial switch to the backup configuration from the TFTP server.

The screenshot shows the 'Industrial Switch' web interface. The top navigation bar includes the 'ADVANTECH' logo on the left and 'Industrial Switch' on the right. Below the navigation bar is a 'Configuration Backup' section with two tabs: 'TFTP Restore Configuration' (selected) and 'TFTP Backup Configuration'. The 'TFTP Restore Configuration' tab contains two input fields: 'TFTP Server IP Address' with the value '192.168.1.2' and 'Restore File Name' with the value 'data.dat'. Below these fields are 'Apply' and 'Help' buttons. On the left side, there is a sidebar menu with 'Open all' and several expandable categories: 'Main Page', 'System', 'Port', 'Protocol', 'Configuration Backup' (expanded), 'Factory Default', 'Save Configuration', and 'System Reboot'.

Figure 3.34: TFTP Restore Configuration

#### TFTP Restore Configuration

- **TFTP Server IP Address:** Enter the IP address of the TFTP server.
- **Restore File Name:** Enter the file name to be restored.
- Click  .

The screenshot shows the 'Industrial Switch' web interface. The top navigation bar includes the 'ADVANTECH' logo on the left and 'Industrial Switch' on the right. Below the navigation bar is a 'Configuration Backup' section with two tabs: 'TFTP Restore Configuration' and 'TFTP Backup Configuration' (selected). The 'TFTP Backup Configuration' tab contains two input fields: 'TFTP Server IP Address' with the value '192.168.1.2' and 'Backup File Name' with the value 'data.dat'. Below these fields are 'Apply' and 'Help' buttons. On the left side, there is a sidebar menu with 'Open all' and several expandable categories: 'Main Page', 'System', 'Port', 'Protocol', 'Configuration Backup' (expanded), 'Factory Default', 'Save Configuration', and 'System Reboot'.

Figure 3.35: TFTP Backup Configuration

- **TFTP Server IP Address:** Enter the IP address of the TFTP server.
- **Backup File Name:** Enter the file name for the backup configuration.
- Click  .



### 3.1.5 Factory Default

Reset switch to the default configuration. Click **Reset** to reset all configurations to the default value.

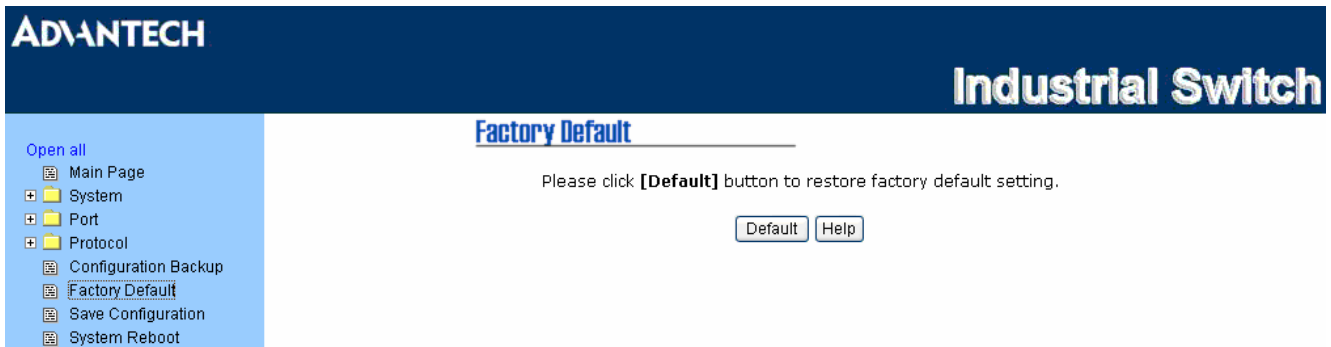

Figure 3.36: Factory Default

### 3.1.6 Save Configuration

Save all configurations that you have made in the system. To ensure all configurations will be saved, click **Save** to save all configurations to the flash memory.



Figure 3.37: Save Configuration

### 3.1.7 System Reboot

Reboot the switch in software reset. Click **Reboot** to reboot the system.

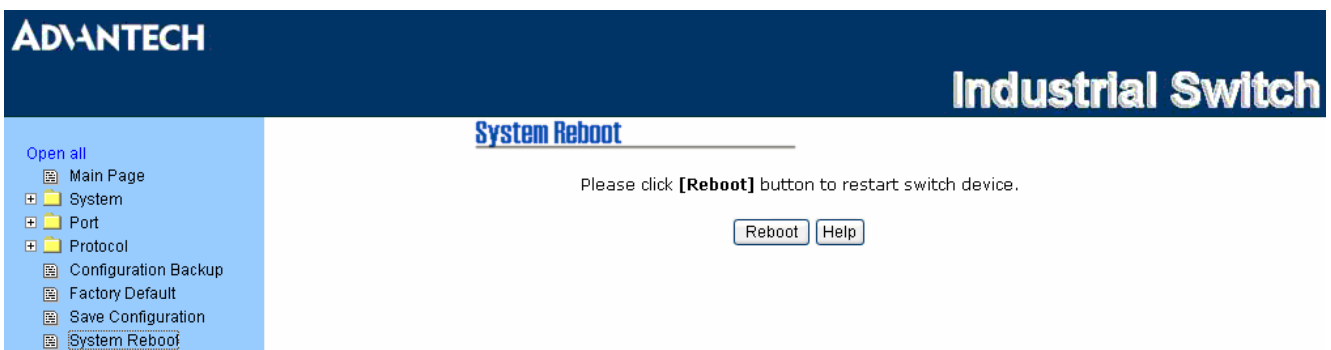

Figure 3.38: System Reboot



CHAPTER  
**4**

**Troubleshooting**

## Chapter 4 Troubleshooting

Verify that you are using the right power cord/adaptor. Don't use the power adaptor with DC output voltage higher than the power input rating of the equipment, or it will burn down.

Select the proper UTP cable to construct the user network. Use unshielded twisted-pair (UTP) or shield twisted-pair (STP) cable for RJ-45 connections: 100  $\Omega$  Category 3, 4 or 5 cable for 10Mbps connections, 100  $\Omega$  Category 5 cable for 100Mbps connections, or 100  $\Omega$  Category 5e/above cable for 1000Mbps connections. Also be sure that the length of any twisted-pair connection does not exceed 100 meters (328 feet).

### Diagnosing LED Indicators

To assist in identifying problems, the switch can be easily monitored through panel indicators, which describe common problems the user may encounter and where the user can find possible solutions.

If the power indicator does not light up when the power cord is plugged in, you may have a problem with power cord. Then check for loose power connections, power losses or surges at power outlet. If you still cannot resolve the problem, contact the local dealer for assistance.

If the LED indicators are normal and the connected cables are correct but the packets still cannot be transmitted, please check the user system's Ethernet devices' configuration or status.

**APPENDIX  
A**

**Pin Assignments &  
Wiring**

# Appendix A Pin Assignments & Wiring

## A.1 RJ-45 Port

---

It is suggested to adopt ELA/TIA as the wiring of the RJ-45.

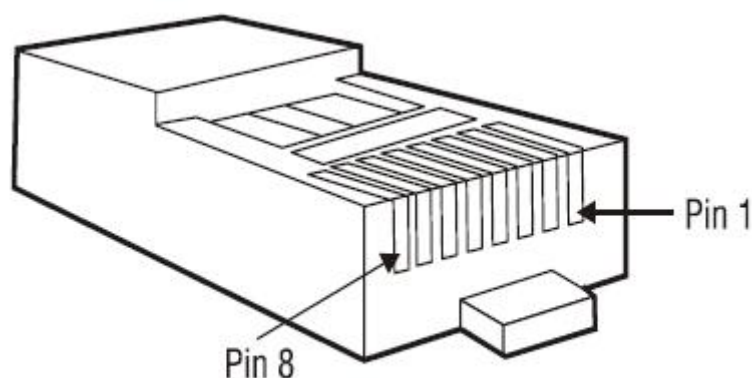

Figure A.1: RJ-45 Pin Assignments

### RJ-45 Pin Assignments

Pin Number	Function
1	TX+
2	TX-
3	RX+
6	RX-

*Note* “+” and “-” signs represent the polarity of the wires that make up each wire pair.

All ports on this industrial switch support automatic MDI/MDI-X operation, you can use straight-through cables (See the figure below) for all network connections to PCs or servers, or to other switches or hubs. In straight-through cable, pins 1, 2, 3, and 6, at one end of the cable, are connected straight through to pins 1, 2, 3 and 6 at the other end of the cable. The 10BASE-T/100BASE-TX MDI and MDI-X port pinouts are described below.

## MDI/MDI-X Pin Assignments

Pin Number	MDI-X Signal Name	MDI Signal Name
1	Receive Data plus (RD+)	Transmit Data plus (TD+)
2	Receive Data minus (RD-)	Transmit Data minus (TD-)
3	Transmit Data plus (TD+)	Receive Data plus (RD+)
6	Transmit Data minus (TD-)	Receive Data minus (RD-)

### Straight-through Cable Schematic

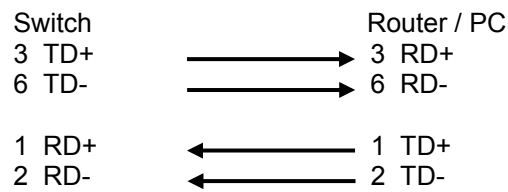

### Cross-over Cable Schematic

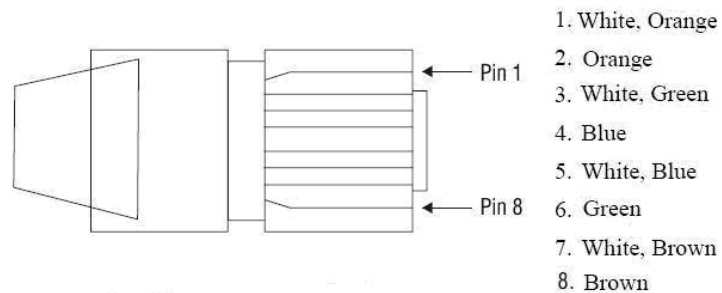
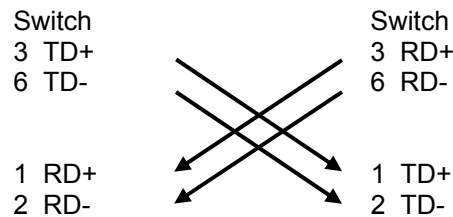

Figure A.2: EIA/TIA-568B

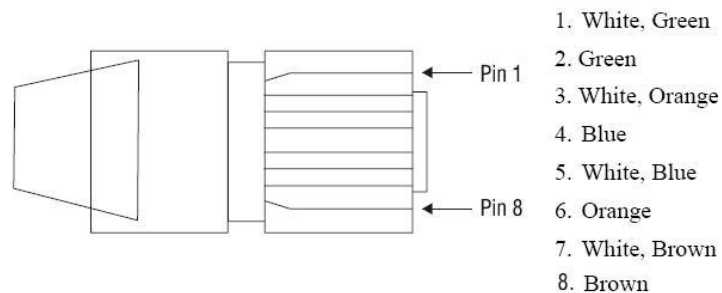

Figure A.3: EIA/TIA-568A

## A.2 Fiber Port

---

The switch is equipped with two 100Base-FX ports which are SC type connectors in multi mode (2Km) or single mode (30Km).

Please refer to the illustration below to connect the fiber port to another one. Wrong connection will not allow the port to work normally.

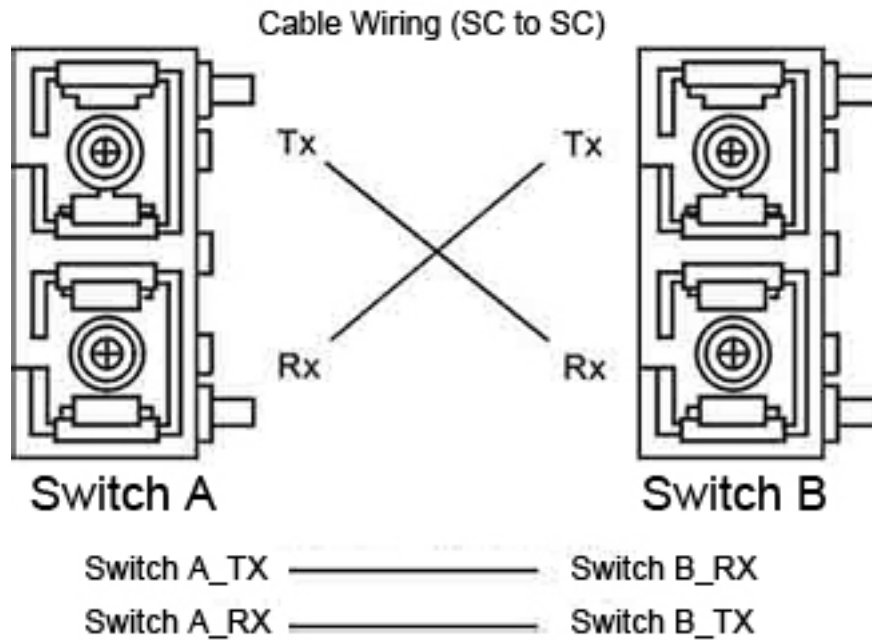

---

### ATTENTION



This is a Class 1 Laser/LED product. Don't stare into the Laser/LED Beam.

---