

# Zlinx Xtreme

## IP67 Radio Modem

### USER MANUAL



**B+B** SMARTWORX

Powered by



**Advantech B+B SmartWorx - Americas**

707 Dayton Road  
Ottawa, IL 61350 USA  
**Phone** (815) 433-5100  
**Fax** (815) 433-5105

**Advantech B+B SmartWorx - European Headquarters**

Westlink Commercial Park  
Oranmore, Co. Galway, Ireland  
**Phone** +353 91-792444  
**Fax** +353 91-792445

[www.advantech-bb.com](http://www.advantech-bb.com)  
[support@advantech-bb.com](mailto:support@advantech-bb.com)

©2018 B+B SmartWorx. No part of this publication may be reproduced or transmitted in any form or by any means, electronic or mechanical, including photography, recording, or any information storage and retrieval system without written consent. Information in this manual is subject to change without notice, and does not represent a commitment on the part of B+B SmartWorx.

B+B SmartWorx shall not be liable for incidental or consequential damages resulting from the furnishing, performance, or use of this manual.

All brand names used in this manual are the registered trademarks of their respective owners. The use of trademarks or other designations in this publication is for reference purposes only and does not constitute an endorsement by the trademark holder.

**TABLE OF CONTENTS**

**Table of Contents**..... **iii**

**1 - Overview** ..... **1**

1.1 PREREQUISITES ..... 1

1.2 SAFETY INFORMATION ..... 1

1.3 INSTALLATION INFORMATION ..... 1

1.4 ABOUT THIS MANUAL ..... 2

1.5 PRODUCT FEATURES SUMMARY ..... 2

**2 - Product Information** ..... **3**

2.1 ZLINX<sup>®</sup> XTREME RADIO MODEM MODELS ..... 3

2.2 PACKAGE CONTENTS ..... 3

2.3 MODES OF OPERATION ..... 3

    2.3.1 Point-to-Point Serial ..... 3

    2.3.2 Point-to-Point Serial to Xtreme I/O ..... 3

    2.3.3 Point-to-Multi Point (Serial or Xtreme I/O) ..... 3

2.4. OPERATING STATES ..... 4

    2.4.1 Idle State ..... 4

    2.4.2 Transmit State ..... 4

    2.4.3 Receive State ..... 4

    2.4.4 Sleep State ..... 4

    2.4.5 Command Mode ..... 4

2.5 USER INTERFACE COMPONENTS ..... 4

    2.5.1 Signal Strength (RSSI) LED's ..... 4

    2.5.2 Transmit LED ..... 4

    2.5.3 Receive LED ..... 4

    2.5.4 Power LED ..... 5

    2.5.5 Internal User Interfaces ..... 5

    2.5.6 Push Button ..... 5

    2.5.7 USB Connector ..... 6

    2.5.8 Terminal Block ..... 6

**2.5.9 DIP Switch** ..... **7**

**3.0 Hardware Installation**..... **8**

3.1 MECHANICAL DIAGRAM..... 8

3.2 IP67 CABLE GLAND INSTALLATION .....	8
3.2.1 Cable Gland Description .....	8
3.2.2 Cable Gland Installation .....	9
3.3 WATERTIGHT THREADED CONDUIT HUB .....	9
3.3.1 Description .....	9
3.3.2 Water Tight Threaded Conduit Installation .....	9
3.4 IP67 MEMBRANE CABLE GLAND .....	10
3.4.1 Description .....	10
3.4.2 IP67 Membrane Cable Gland Installation .....	10
3.5 SUPPLIED ANTENNA .....	10
3.5.1 ZXT9-RM Supplied Antenna .....	10
3.5.2 ZXT24-RM Supplied Antenna .....	11
3.6 OPTIONAL ANTENNAS.....	11
3.6.1 Omni Antenna Description .....	11
3.6.2 Yagi Antenna Description.....	13
3.7 ANTENNA CABLES .....	14
3.8 LIGHTNING ARRESTORS.....	15
<b>4 - Electrical Installation.....</b>	<b>16</b>
4.1 WIRING.....	16
4.1.1 Terminal Block .....	16
4.1.2 Power Supply Connections .....	16
4.1.3 RS-232 Connections .....	17
4.1.4 RS-485 Two-Wire Connections.....	18
4.1.5 RS-422/485 Four-Wire Connections.....	18
4.1.6 Termination and Biasing .....	19
4.1.7 Fault Output.....	19
<b>5 - Software Installation.....</b>	<b>21</b>
5.1 ZLINX <sup>®</sup> MANAGER SOFTWARE OVERVIEW .....	21
5.1.1 Computer System Requirements.....	21
5.2 INSTALLING ZLINX <sup>®</sup> MANAGER SOFTWARE .....	21
5.2.1 Installing Zlinx <sup>®</sup> Manager Software .....	21
5.2.2 Installing USB Drivers .....	24
5.3 STARTING ZLINX <sup>®</sup> MANAGER SOFTWARE .....	24
5.3.1 Starting the manager software .....	24

5.3.2	Radio Modem Configuration Screen .....	25
5.3.3	Radio Modem Configuration Screen (Off-Line).....	49
5.3.4	Radio Modem Firmware Update Screen.....	49
5.3.5	Return to Manager .....	49
5.3.6	Exit .....	49
<b>6</b>	<b>- Startup and Configuration .....</b>	<b>50</b>
6.1	BASIC SETTINGS .....	50
6.1.1	Channel Number .....	50
6.1.2	Network Identifier .....	50
6.1.3	Baud Rate, Stop Bits, Parity, and Flow Control .....	50
6.2	ADVANCED SETTINGS.....	50
6.3	RF MODEM OPERATION .....	50
6.3.1	Transport Operation .....	50
6.3.2	Serial to RF Packetization.....	51
6.3.3	API Operation.....	51
6.3.4	Flow Control .....	52
6.3.5	Sleep Mode .....	53
6.3.5.3	CYCLE SLEEP MODE .....	54
6.3.6	Command Mode.....	54
6.3.7	AT Command Mode .....	55
6.3.8	Binary Command Mode .....	55
6.4	ZXT9-RM CONFIGURATION.....	57
6.4.1	Advanced PrograMming.....	57
6.4.2	Command Reference Table .....	58
6.4.2.1	AT Commands & Descriptions.....	61-129
6.5	ZXT24-RM CONFIGURATION.....	81
6.5.1	Advanced Programming.....	81
6.6	FIRMWARE UPDATE .....	130
6.6.1	Caution .....	130
6.6.2	FIRMWARE UPDATE PROCEDURE.....	130
<b>7</b>	<b>- Use Cases.....</b>	<b>132</b>
7.1	POINT-TO-POINT SERIAL.....	132
7.1.1	Use Case Parameters.....	132
7.2	POINT-TO-POINT SERIAL TO XTREME I/O.....	137

7.2.1 Use Case Parameters ..... 137

**8 - Testing and Trouble Shooting..... 138**

    8.1 RSSI RANGE TEST ..... 138

**Appendix A – Specifications..... 140**

**Appendix B – Default Configurations ..... 143**

    B.1 RESTORE DEFAULT CONFIGURATIONS ..... 143

    B.2 ZKT9-RM DEFAULT CONFIGURATION ..... 143

    B.3 ZKT24-RM DEFAULT CONFIGURATION ..... 144

**Appendix C – Dimensional Diagram / Mounting Instructions ..... 146**

    C.1 DIMENSIONAL DIAGRAM ..... 146

    C.2 MOUNTING ..... 147

    C.3 SUPPLIED ANTENNA..... 148

**Appendix D – Radio Frequency Basics ..... 150**

    D.1 WHAT IS DBM? ..... 150

    D.2 LOWER FREQUENCIES = BETTER PROPAGATION ..... 150

    D.3 RANGE IS NOT JUST A FUNCTION OF TRANSMITTER POWER ..... 150

    D.4 YOU MUST CONSIDER RF NOISE ..... 151

    D.5 FADE MARGIN IS CRITICAL FOR RELIABLE OPERATION IN ADVERSE WEATHER AND INTERFERENCE..... 151

    D.6 REMEMBER YOUR MATH ..... 151

    D.7 RF ATTENUATION AND LINE OF SIGHT..... 152

    D.8 PATH LOSS RULE OF THUMB ..... 153

    D.9 ANTENNAS..... 153

    D.10 CABLE LOSS ..... 153

    D.11 LATENCY AND PACKETIZATION ..... 153

**1 - OVERVIEW**

**1.1 PREREQUISITES**

This manual assumes you have a basic understanding of wireless communications, serial protocols (RS-232/422/485), and basic electronics.

**1.2 SAFETY INFORMATION**

**WARNING**



Exposure to RF energy is an important safety consideration. The FCC has adopted a safety standard for human exposure to radio frequency electromagnetic energy emitted by FCC regulated equipment as a result of its actions in Docket 93-62 and OET Bulletin 65 Edition 97-01.

DO NOT OPERATE unless all RF connectors are secure and any open connectors are properly terminated.

A separation distance of 20 cm or more should be maintained between the antenna of this device and persons during device operation. To ensure compliance, operation at closer than this distance is not recommended. The antenna used for this device must not be co-located in conjunction with any other antenna or transmitter.

**1.3 INSTALLATION INFORMATION**

<b>Operating Voltage</b>	10 to 30 VDC
<b>Maximum Surrounding Ambient Air Temp</b>	74 °C
<b>Wiring Terminals</b>	Use Copper Wire Only, One Conductor Per Terminal
<b>Wire Range</b>	30 to 12 AWG
<b>Tightening Torque</b>	0.5 to 0.6 Nm
<b>Temperature Rating of Field Installed Conductors</b>	105 °C minimum, sized for 60 °C ampacity

*Note: Please see the Quick Start Guide for UL Class 1 / Division 2 installation instructions.*

## 1.4 ABOUT THIS MANUAL

This manual has been created to assist you in installing, configuring, operating, and troubleshooting your Zlinx<sup>®</sup> Xtreme Radio Modem. It is divided into key sections as follows:

**Product Information** – covers what is included with your radio modem, operating modes, operating states and user interface components.

**Hardware Installation** – covers how to install your radio modem. Additional information is provided about RF considerations, accessory antennas and cable selection.

**Electrical Installation** – covers wiring connections and powering your radio modem.

**Software Installation** – covers installing the manager software and basic software functionality.

**Startup and Configuration** – contains more detailed information about how to configure your radio modem.

**Use Cases** – contains information concerning the most widely used configurations.

**Testing and Troubleshooting** – contains information about trouble shooting aids.

**Appendices** – additional information.

## 1.5 PRODUCT FEATURES SUMMARY

Need to extend an RS-232/422/485 signal across a highway or across the building? Your Zlinx<sup>®</sup> Xtreme Radio Modem will do the job faster, easier, and less expensively than stringing cable. The Zlinx Xtreme Radio Modem connects serial devices which can be set up in point to point or point to multi point networks. Easy plug-and-play set-up saves installation and maintenance time. In addition, Zlinx Xtreme Radio Modem meets the IP67 standard and is built to handle the heat, cold and environments of industrial operations.

- Modbus compatible – no additional converters needed
- RS-232, 422, 485 (2-wire & 4-wire) serial communications
- Frequency range: ISM band, 902 to 928 MHz or 2.4 to 2.5 GHz
- Signal strength indicators aids troubleshooting.
- 900 MHz or 2.4 GHz antenna included
- 256-bit AES Encryption
- Wide Operating Temperature: -40 to +74°C
- Rugged Circuitry for Indoor and Outdoor Applications
- IP67 Rated for total protection against dust and water up to 1 meter
- Software support Windows XP, Vista, 7, 8, 8.1, 10 (32 / 64 bit)
- Field Upgradable Firmware

## 2 - PRODUCT INFORMATION

### 2.1 ZLINX® XTREME RADIO MODEM MODELS

ZXT9-RM – 900 MHz ISM Band Radio Modem

ZXT24-RM – 2.4 GHz ISM Band Radio Modem

### 2.2 PACKAGE CONTENTS

- Zlinx Xtreme Radio Modem
- Software CD
- Quick Start Guide
- Antenna
- Enclosure Mounting Ears and Hardware

**Note:** Cable Glands cannot be used for Class 1/Division 2 applications. Please see the Quick Start Guide for additional information about UL Class 1/Division 2 installation instructions.

### 2.3 MODES OF OPERATION

#### 2.3.1 POINT-TO-POINT SERIAL

This configuration is used to wirelessly transmit serial data from one location to another. A Zlinx Xtreme Radio Modem is configured with another radio modem of same frequency in a master slave relationship to transmit serial data wirelessly. Typical applications include connecting a device such as a pressure/flow transmitter to a PLC or SCADA system.

#### 2.3.2 POINT-TO-POINT SERIAL TO XTREME I/O

This configuration is employed to connect a PLC/HMI/SCADA system to a remote Xtreme I/O (or Zlinx standard I/O) module to monitor or control discrete devices via Modbus. The serial master (PLC/HMI/SCADA) is a Modbus RTU master and must be connected to the serial port of the Radio Modem. Each Xtreme I/O device populates and updates its own Modbus map and support Modbus RTU Slave format. The radio modem is connected to the respective Modbus Master. Typical examples include a water tank monitoring system where a float sensor level data is transmitted to a HMI through the wireless network.

#### 2.3.3 POINT-TO-MULTI POINT (SERIAL OR XTREME I/O)

A Radio Modem is configured to communicate with multiple other modems or I/O modules. The “master” modem is connected to the Modbus Master and can communicate with Modbus Slaves connected to other radio modems or Xtreme I/O units. An example is a PLC Process control/monitoring application requiring analog, digital and serial data to be brought to a central PLC.

## 2.4. OPERATING STATES

The Zlinx Radio Modem has a variety of operating states:

### 2.4.1 IDLE STATE

- Checks for valid RF data received and *discards* invalid data
- Checks for serial data to be packaged and RF transmitted
- Received valid RF data in buffer to be output serially
- Checks if Sleep Mode condition is met
- Checks for Command Mode commands

### 2.4.2 TRANSMIT STATE

- Packages serial data (2048 bytes maximum in RF packet)
  - ZXT9RM – 2048 bytes maximum
  - ZXT24RM – 202 bytes maximum
- Returns to Idle State

### 2.4.3 RECEIVE STATE

- Switches to Receive State to start receiving RF packets if RF data was detected while in the Idle State
- Returns to Idle State when data is no longer detected or an error is detected

### 2.4.4 SLEEP STATE

- This allows the radio modem to enter a state of low power consumption when not in use.

### 2.4.5 COMMAND MODE

- Enters AT Command mode with +++ sent to serial input with Guard Time before and after. Exits after Timeout. The guard times and the entry characters are user configurable.

## 2.5 USER INTERFACE COMPONENTS

### 2.5.1 SIGNAL STRENGTH (RSSI) LED'S

There are eight green LED's to indicate signal strength (Received Signal Strength Indicator, "RSSI"). They are arranged to indicate RSSI from weakest (bottom LED lighted) to strongest (all eight LED's lighted). See figure 2-1.



Figure 2-1 RSSI Indicator

### 2.5.2 TRANSMIT LED

The green transmit LED flashes when data is transmitted out the serial port. See figure 2-2 below.

### 2.5.3 RECEIVE LED

The green receive LED flashes when data is received by the serial port. See figure 2-2 below.

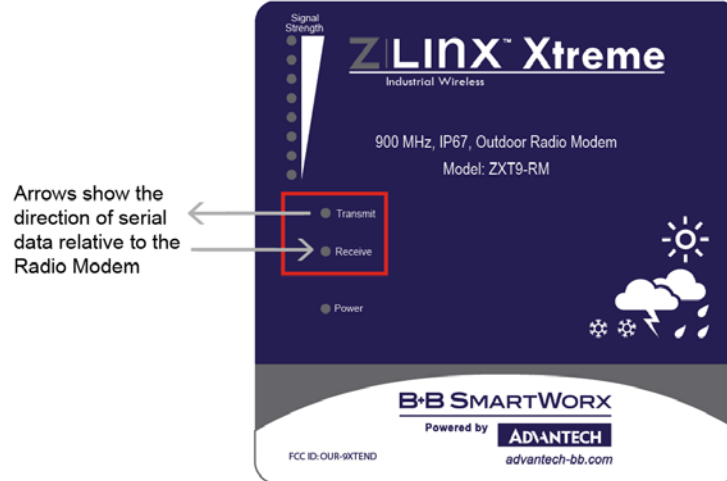
**Figure 2-2 Transmit and Receive LEDs**

### 2.5.4 POWER LED

The green power LED is ON when power is applied.

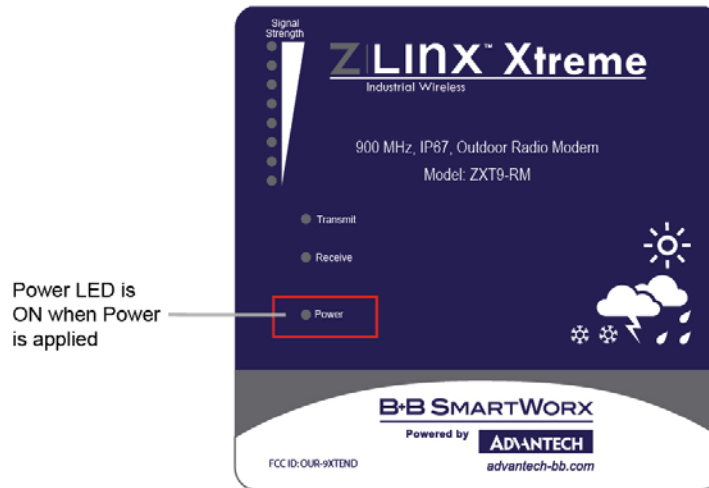
**Figure 2-3 Power LED**

### 2.5.5 INTERNAL USER INTERFACES

The remaining user interfaces are located inside the radio modem enclosure. To access these interfaces, the cover must be removed. The cover is held in place with four plastic Phillips style screws.

### 2.5.6 PUSH BUTTON

Push Button PB1 is located on the circuit board behind the radio modem cover. It is used to temporarily set the serial port to a known condition. To do this, use the RS-232 port. Press and hold the button while power cycling the device. Once power comes up, release the button and the unit will temporarily be restored to a known condition and in command mode for about 20 seconds. You will then be able to connect to the device using the manager at the settings below:

- Baud rate = 9600
- Data bit = 8
- Parity = None
- Stop bit = 1

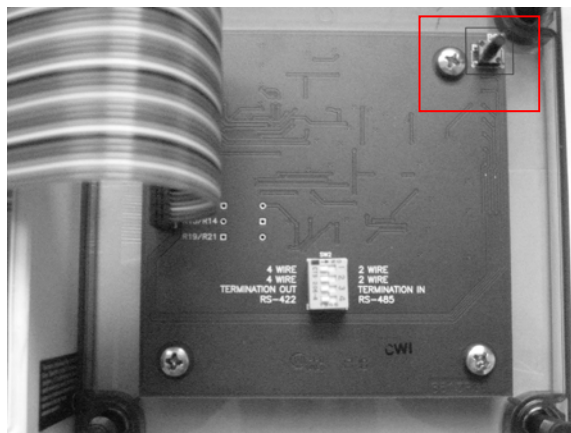
**Figure 2-4 Push Button**

### 2.5.7 USB CONNECTOR

The USB connector is located on the circuit board inside the radio modem enclosure. It is used to connect a PC to the radio modem to perform configurations and firmware updates. The connector is a Type B female. Any commercially available USB cable can be used to connect to the radio modem. Figure 2-5 shows the USB connector location.

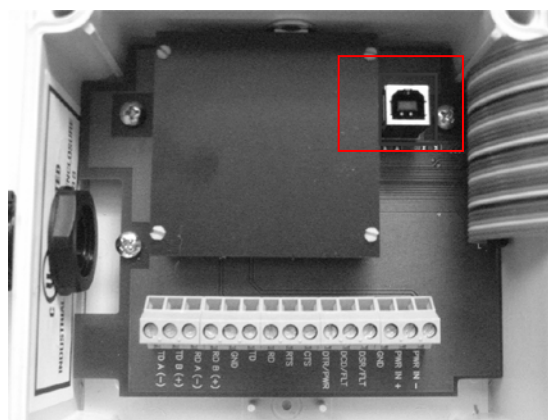
**Figure 2-5 USB Connector**

### 2.5.8 TERMINAL BLOCK

The terminal block is used to connect serial signals and power. Figure 2-6 shows the TB location.

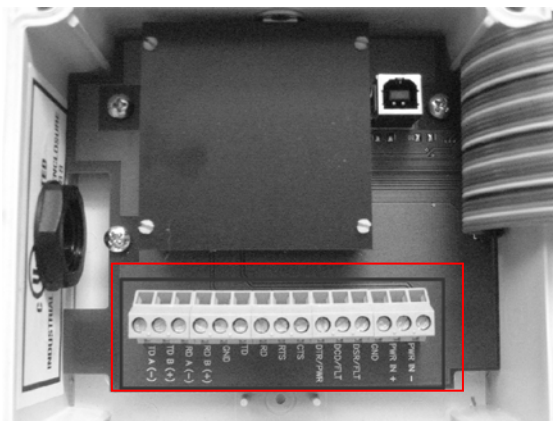
**Figure 2-6 Terminal Block**

2.5.9 DIP SWITCH

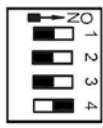
OFF		ON	Switch	RS-232	RS-422	RS-485 4-Wire	RS-485 2-Wire
4-Wire		2-Wire	1	OFF	OFF	OFF	ON
4-Wire		2-Wire	2	OFF	OFF	OFF	ON
Termination Out		Termination In	3	OFF	OFF*	OFF*	OFF*
RS-422		RS-485	4	OFF	OFF	ON	ON

**Note:** The use of built in termination is optional and depends on your application.

**Note:** For RS-232 operation, set all switches OFF.

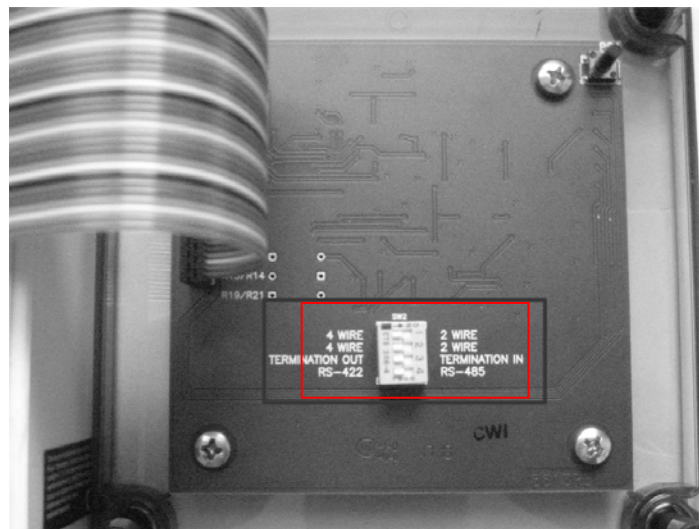

Figure 2-7 DIP Switch

**3.0 HARDWARE INSTALLATION**

**3.1 MECHANICAL DIAGRAM**

The mechanical diagram in Appendix C contains information for mounting your radio modem.

*Note: the Cable Glands cannot be used for Class 1/Division 2 applications. Please see the Quick Start Guide for UL Class 1/Division 2 installation instructions.*

**3.2 IP67 CABLE GLAND INSTALLATION**

**3.2.1 CABLE GLAND DESCRIPTION**

The Cable Gland is used to maintain the water tight rating while allowing a cable to enter the enclosure. The assembly consists of black molded nylon body, hex nut, cable nut and a rubber gasket and cable seal.



Figure 3-1 IP67 Cable Gland

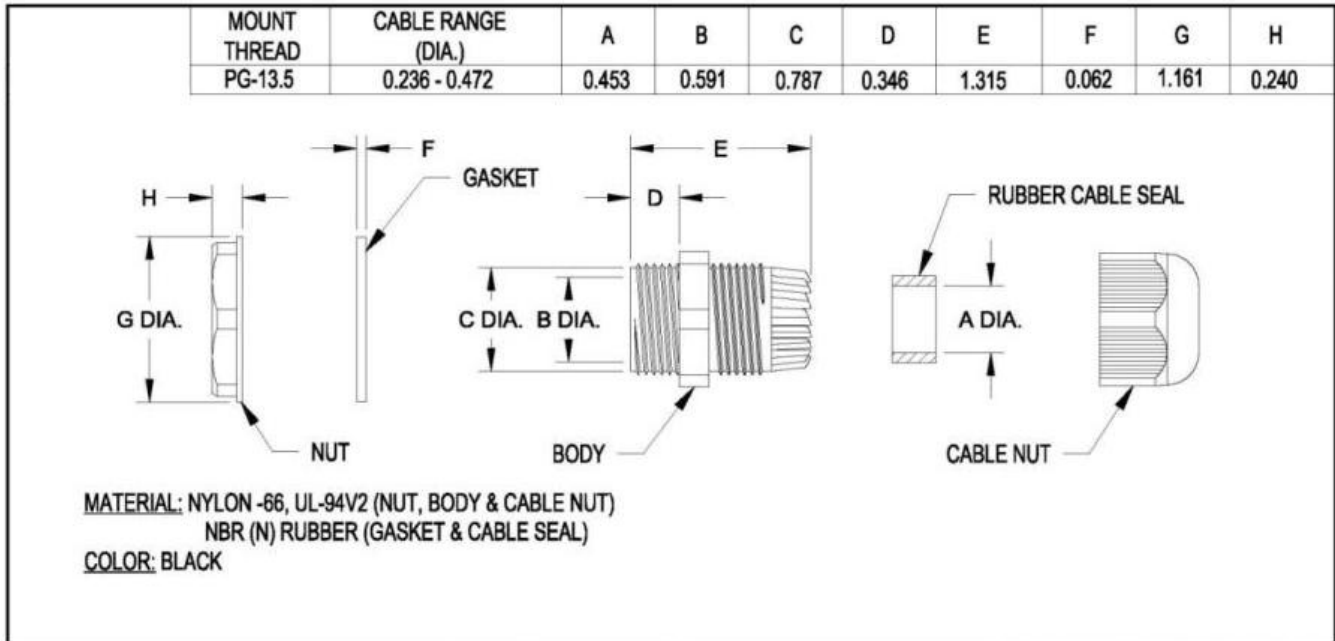

Figure 3-2 IP67 Cable Gland

### 3.2.2 CABLE GLAND INSTALLATION

1. The Cable Gland will accept cable diameters from 0.236 to 0.472 inches (5.99 to 11.99 mm).
2. Insert the non-tapered end of the Body (D) through the conduit knock-out on the radio modem enclosure.
3. Place the Gasket around the body on the outside of the enclosure.
4. Thread the Hex Nut onto the Body from the inside of the enclosure.
5. Place the Cable Nut onto the cable being careful to position the threaded side so that it can be attached to the Cable Body.
6. Tighten the Cable Nut. This will cause the tapered end of the Cable Body to compress, ensuring a water-tight seal.

### 3.3 WATERTIGHT THREADED CONDUIT HUB

**Note:** Unused conduit openings: Class 1/Division 2 installation requires a UL Recognized conduit plug (UL Category Code QCRV2) be used when a conduit opening is not being used.

#### 3.3.1 DESCRIPTION

Another method to bring a cable into the enclosure is to use the water tight threaded conduit hub. It is used to secure threaded half-inch rigid service entrance conduit. It consists of a Body, Nut and Gasket.



**Figure 3-3 1/2 Inch Threaded Conduit Hub**

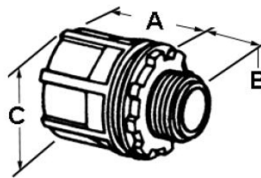

<b>A</b>	<b>3/16 in</b>
<b>B</b>	<b>9/16 in</b>
<b>C</b>	<b>1 1/8 in</b>

**Figure 3-4 1/2 Inch Threaded Conduit Hub**

#### 3.3.2 WATER TIGHT THREADED CONDUIT INSTALLATION

1. Insert the threaded end of the body into the conduit knock-out from the outside of the enclosure. The rubber gasket should be on the outside of the enclosure.
2. Thread the nut onto the conduit body from inside the enclosure.
3. 1/2 and 3/8 inch conduit fittings as well as 1/2 inch, rigid, threaded conduit can be attached to the threaded hub.

**3.4 IP67 MEMBRANE CABLE GLAND**

*Note: the Cable Glands cannot be used for Class 1/Division 2 applications. Please see the Quick Start Guide for UL Class 1/Division 2 installation instructions.*

**3.4.1 DESCRIPTION**

The membrane cable gland is used to plug an unused hole in the enclosure.



**Figure 3-5 IP67 Membrane Cable Gland**

**3.4.2 IP67 MEMBRANE CABLE GLAND INSTALLATION**

1. Stuff the cable gland into the knock-out hole with the narrow end toward the inside of the radio modem enclosure. The enclosure wall will fit into the indentation between the inside and outside portions of the gland.

**3.5 SUPPLIED ANTENNA**

**3.5.1 ZXT9-RM SUPPLIED ANTENNA**

Your Zlinx Xtreme 900 MHz product comes supplied with a “rubber duck” style antenna which can be articulated up to 90 degrees. Then antenna is a ¼ wave dipole with an omni-directional pattern and vertical polarization. It is recommended that your Zlinx Xtreme product be mounted vertically.

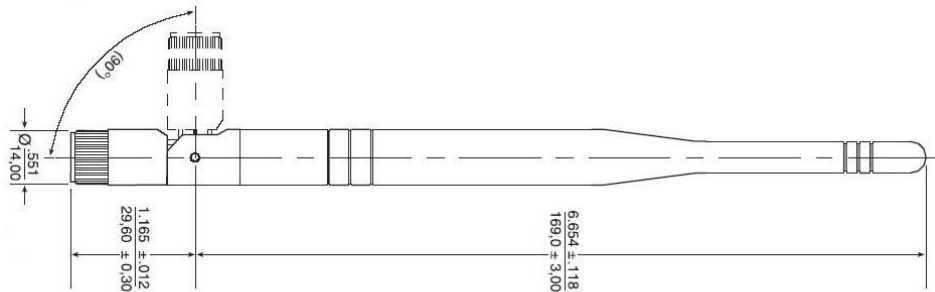

**Figure 3-6 ZXT9-RM Supplied Antenna**

<b>Impedance</b>	50Ω
<b>Connector</b>	RPSMA Female
<b>VSWR</b>	2.0 Max (in-band)
<b>Gain</b>	3.0 dBi
<b>Polarization</b>	Vertical
<b>Replacement Part Number</b>	ZXT9-ANT1

**3.5.2 ZXT24-RM SUPPLIED ANTENNA**

Your Zlinx Xtreme 2.4 GHz product comes supplied with a “rubber duck” style antenna which can be articulated up to 90 degrees. Then antenna is a ¼ wave dipole with an omni-directional pattern and vertical polarization.

It is recommended that your Zlinx Xtreme product be mounted with the antenna on the top, perpendicular with the horizon

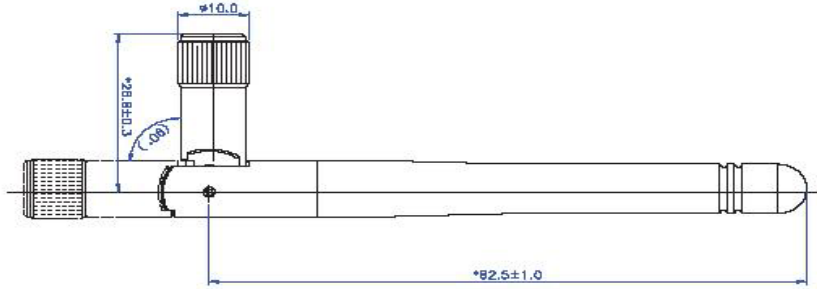

**Figure 3-7 ZXT24-RM Supplied Antenna**

<b>Impedance</b>	50Ω
<b>Connector</b>	RPSMA Female
<b>VSWR</b>	2.0 Max (in-band)
<b>Gain</b>	2.1 dBi
<b>Polarization</b>	Vertical
<b>Replacement Part Number</b>	ZZ24D-ANT1

**3.6 OPTIONAL ANTENNAS**

**3.6.1 OMNI ANTENNA DESCRIPTION**

In some applications, a higher gain omni-directional antenna may be required. An omni-directional antenna is an antenna system that radiates power uniformly in one plane with a directive pattern shape in a perpendicular plane. This pattern is often described as "donut shaped". An omni-directional antenna can be used to link multiple directional antennas in outdoor point-to-multipoint communication.

Omni-directional antennas are a good choice if you need to mount your antenna on a mast to increase its elevation. Please note that mounting brackets must also be purchased. Also note that these antennas have an N style connector. Refer to section 3.9 to select the correct cable. (Contact B+B SmartWorx for antenna model information and availability.)



**Figure 3-8 Representative Photograph of Optional Omni Antenna**

**Model FG9023 – High Gain Omni Directional (900 MHz)**

<b>Use With</b>	ZXT9-RM (900 MHz)
<b>Impedance</b>	50Ω
<b>Connector</b>	N Female
<b>VSWR</b>	2:1 maximum (In Band)
<b>Gain</b>	3 dBi
<b>Polarization</b>	Vertical
<b>Length</b>	25 inches (63.5 cm)
<b>Mounting Brackets (Not Included)</b>	FM2

**Model FG24008 – High Gain Omni Directional (2.4 GHz)**

<b>Use With</b>	ZXT24-RM (2.4 GHz)
<b>Impedance</b>	50Ω
<b>Connector</b>	N Female
<b>VSWR</b>	1.5:1 maximum (In Band)
<b>Gain</b>	8 dBi
<b>Polarization</b>	Vertical
<b>Length</b>	24.5 inches (62.2 cm)
<b>Mounting Brackets (Not Included)</b>	FM2

**3.6.2 YAGI ANTENNA DESCRIPTION**

A Yagi-Uda Antenna, commonly known simply as a Yagi antenna or Yagi, is a *directional antenna* system consisting of an array of a dipole and additional closely coupled parasitic elements (usually a reflector and one or more directors). The dipole in the array is driven, and another element, typically 5% longer, effectively operates as a reflector. Other parasitic elements shorter than the dipole may be added in front of the dipole and are referred to as directors. This arrangement increases antenna directionality and gain in the preferred direction over a single dipole. (Contact B+B SmartWorx for antenna model information and availability.)

*Note: Since Yagi Antennas are directional, they must point directly at the other antenna through a clear line of sight.*



**Figure 3-9** Representative Enclosed Yagi Photograph



**Figure 3-10** Representative Yagi Antenna Photograph

<b>Model YS8963 – High Gain Yagi (900 MHz)</b>	
<b>Use With</b>	ZXT9-RM (900 MHz)
<b>Impedance</b>	50Ω
<b>Connector</b>	N Female
<b>VSWR</b>	1.5:1 maximum (In Band)
<b>Gain</b>	6 dBi
<b>Polarization</b>	Vertical
<b>Length</b>	16.8 inches (42.7 cm)
<b>Mounting Brackets</b>	Included

<b>Model YS24008 – High Gain Yagi (2.4 GHz)</b>	
<b>Use With</b>	ZXT24-RM (2.4 GHz)
<b>Impedance</b>	50Ω
<b>Connector</b>	N Female
<b>VSWR</b>	1.5:1 maximum (In Band)
<b>Gain</b>	12.5 dBi
<b>Polarization</b>	Vertical
<b>Length</b>	18 inches (45.7 cm)
<b>Mounting Brackets</b>	Included

### 3.7 ANTENNA CABLES

If you decide to use one of the optional antennas, you will need to select the appropriate cable and connector. It is important to select a cable that matches the radio's impedance. An impedance mismatch will cause the radio link to become inefficient and could damage the radio. Selecting the incorrect cable could also cause significant signal loss. A rule of thumb is: for every 3 dB of loss, your system will lose half the output power emitted from the radio.

B+B SmartWorx offers three basic cable types: LMR100, LMR195, and LMR400. LMR400 cable offers lower loss but is thicker and more difficult to work with. LMR100 is thin and easy to work with, but has a larger loss. It is recommended that you use the shortest possible cable run in your application. (Contact B+B SmartWorx for information and availability.)

Cable Type	900 MHz Loss Per 100 Ft.	2.4 GHz Loss Per 100 Ft.	Diameter
LMR-100	22.8 dB	38.9 dB	0.110 in
LMR-195	11.5 dB	19.0 dB	0.195 in
LMR-400	3.9 dB	6.8 dB	0.405 in

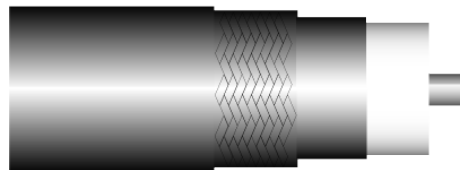
**400M**

50 Ohm, FPE dielectric, AL Tape+95% braid, PE jacket, .405" OD

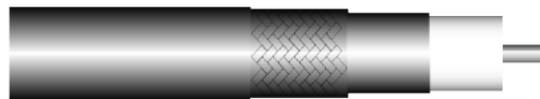
**Figure 3-11** LMR400 Cable Cross Section**195M**

50 Ohm, FPE dielectric, AL Tape+95% braid, PE jckt, .195" OD

**Figure 3-12** LMR195 Cable Cross Section**100M**

50 Ohm, FPE dielectric, AL Tape+95% braid, PE jckt, .105" OD

**Figure 3-13** LMR100 Cable Cross Section

Along with the type of cable, you need to select the correct connector. This product uses an RPSMA Male (plug) connector. Therefore, you will need a cable that has a RPSMA Female (jack) on one end. If you are using one of the optional antennas, you will need an N type Male connector, since these antennas have an N type Female on them. If you are extending the included antenna, you will need an RPSMA Male (plug) since the supplied antenna has an RPSMA female (jack).

### Antenna Cable Part Numbers

B+B SmartWorx has a variety of standard cables for purchase. The cable part number is relatively easy to interpret:

TTTT-AABB-LLLL

TTTT = Cable Type (400M = LMR400, 195M = LMR195, 100M = LMR195)

AA = Connector A (NM = N-Male, SL = RPSMA Male (Plug))

BB = Connector B (NM = N-Male, SL = RPSMA Male (Plug))

In most cases, this portion of the part number will be NMSL for Zlinx Xtreme products.

LLLL = Length in inches (ex: 6 = six inches, leading zeros are not necessary)

So, 400M-NMSL-24 is an LMR400 cable with an N Male on one end and an RPSMA plug on the other, 24 inches in length.

## 3.8 LIGHTNING ARRESTORS

When installed properly, a lightning arrestor can prevent damage to your radio due to high energy transients during lightning strikes. Our arrestors limit surges to less than 45 Volts in approximately 100 nanoseconds. A gas discharge tube changes from an open circuit to a short circuit in the presence of energy and voltage surges giving those surges a direct path to ground, thus protecting equipment.

They are designed with a rugged housing and high quality plated brass "N" connectors. They are available as Models LABH350NN and LABH2400N which both allow bulkhead mounting and connector pass-through. (Contact B+B SmartWorx for more information, availability and ordering.)

**4 - ELECTRICAL INSTALLATION**

*Note: Please see the Quick Start Guide for UL Class 1/Division 2 installation instructions.*

**4.1 WIRING**

**4.1.1 TERMINAL BLOCK**

Both power and data signals are connected to the terminal block. Figure 4-1 shows the layout.

<b>Operating Voltage</b>	10 to 20 VDC
<b>Maximum Surrounding Ambient Air Temperature</b>	74 °C
<b>Wiring Terminals</b>	Use Copper Wire Only, One Conductor Per Terminal
<b>Wire Range</b>	30 to 12 AWG
<b>Tightening Torque</b>	0.5 to 0.6 Nm
<b>Temperature Rating of Field Installed Conductors</b>	105 °C minimum, sized for 60°C ampacity.

**Terminal Block Located Inside Enclosure**

<b>PWR IN -</b>	<b>PWR IN +</b>	<b>GND</b>	<b>FAULT</b>	<b>GND</b>	<b>DTR / SLP</b>	<b>CTS</b>	<b>RTS</b>	<b>RD</b>	<b>TD</b>	<b>GND</b>	<b>RDB (+)</b>	<b>RDA (-)</b>	<b>TDB (+)</b>	<b>TDA (-)</b>
-----------------	-----------------	------------	--------------	------------	------------------	------------	------------	-----------	-----------	------------	----------------	----------------	----------------	----------------

**Figure 4-1 Terminal Block**

**4.1.2 POWER SUPPLY CONNECTIONS**

The radio modem requires power from an external source. The radio modem requires 10 to 30 VDC. Power use depends on the model:

ZXT9RM – 1.7 Watts typical, 5.8 Watts maximum

ZXT24RM – 1.2 Watts typical, 3.5 Watts maximum

Connect the positive and negative power leads to the Power In(+) and Power In (-) terminals on the terminal block.

4.1.3 RS-232 CONNECTIONS

4.1.3.1 RS-232 SIGNAL CONVENTION (DTE / DCE)

There are two types of RS-232 ports: DTE (Data Terminal Equipment) and DCE (Data Communications Equipment). The signal names and pin numbers are the same, but signal flow is opposite. The pin labeled TD can be input, and RD the output.

The two ports types are complementary: the **Output** signals on a DTE port are **Inputs** to a DCE port, and **Output** signals on a DCE port are **Inputs** to a DTE port. The signal names match each other and connect pin for pin. Signal flow is in the direction of the arrows.

**The Radio Modem is a DCE device.**

Figure 4-2 shows RS-232 DTE to RS-232 DCE connections with associated DB9 pin numbers and the signal direction.

DTE Device (Computer) DB9			DTE to DCE Connections		DCE Device (Modem) DB9		
Pin#	DB9	RS-232 Signal Names	Signal Direction	Pin#	DB9	RS-232 Signal Names	
#1	Carrier Detector (DCD)	CD	←	#1	Carrier Detector (DCD)	CD	
#2	Receive Data (Rx)	RD	←	#2	Receive Data (Rx)	RD	
#3	Transmit Data (Tx)	TD	→	#3	Transmit Data (Tx)	TD	
#4	Data Terminal Ready	DTR	→	#4	Data Terminal Ready	DTR	
#5	Signal Ground/Common (SG)	GND	→	#5	Signal Ground/Common (SG)	GND	
#6	Data Set Ready	DSR	←	#6	Data Set Ready	DSR	
#7	Request to Send	RTS	→	#7	Request to Send	RTS	
#8	Clear to Send	CTS	←	#8	Clear to Send	CTS	
#9	Ring Indicator	RI	←	#9	Ring Indicator	RI	
Soldered to DB9 Metal - Shield				Soldered to DB9 Metal - Shield			
		FGND				FGND	

Figure 4-2 Terminal Block

4.1.3.2 WIRING AN RS-232 DEVICE TO THE RADIO MODEM

The Radio Modem supports TD, RD, RTS, and CTS. Please note that if Sleep Mode is enabled, the DTR signal is used to “wake up” the device. Figure 4-3 is a wiring diagram for connecting a DTE device such as a computer or PLC.

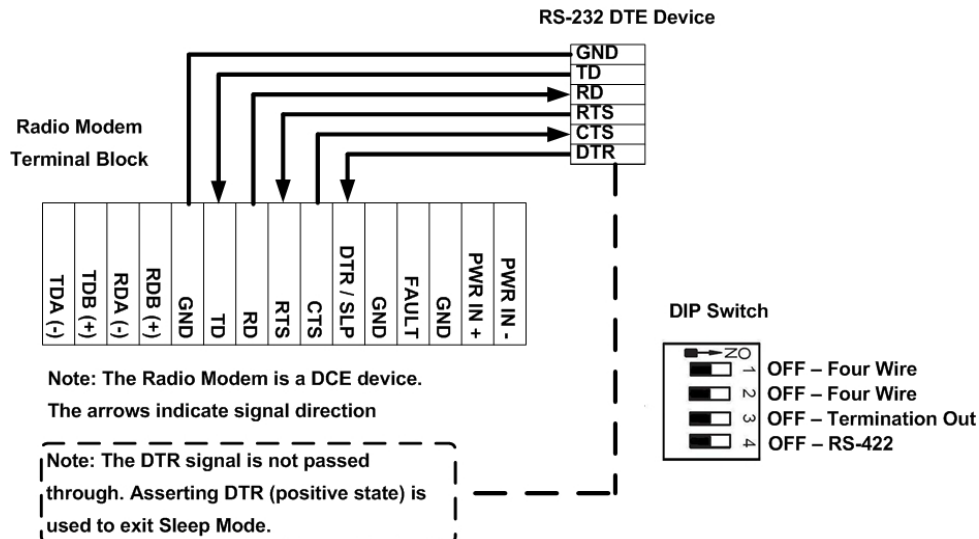
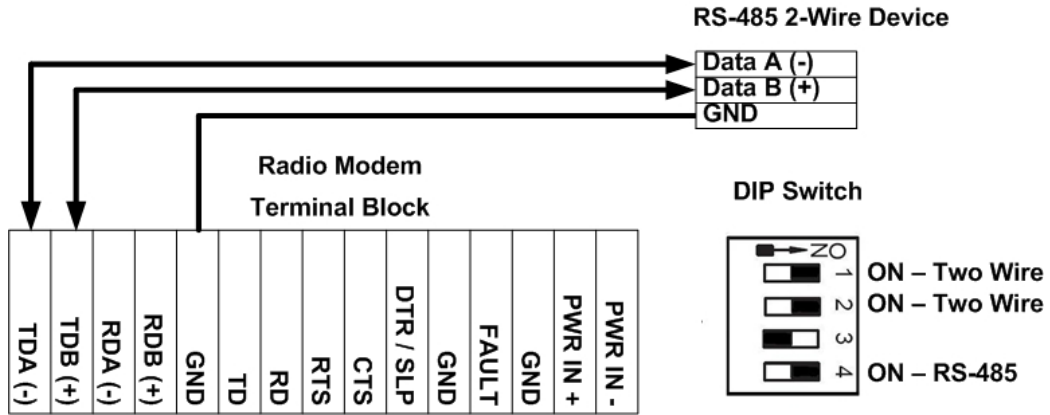

Figure 4-3 RS-232 Wiring

4.1.4 RS-485 TWO-WIRE CONNECTIONS



Note: A (-) and B (+) Signals are tied together when the DIP Switch is configured to 2-Wire Mode.

Figure 4-4 RS-485 2-Wire Wiring

4.1.5 RS-422/485 FOUR-WIRE CONNECTIONS

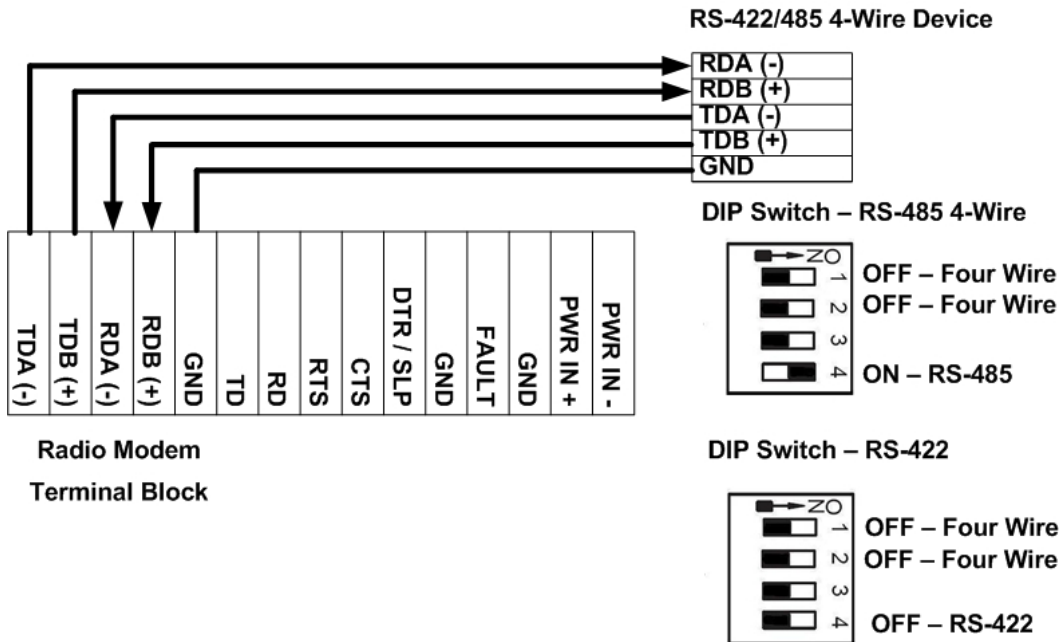
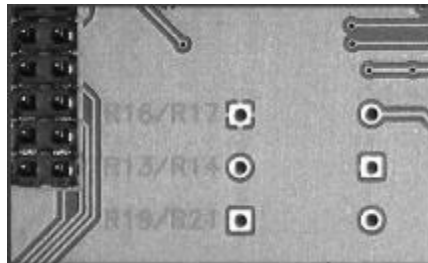

Figure 4-5 RS-422 / 485 4-Wire Wiring

**4.1.6 TERMINATION AND BIASING**

The radio modem has built in 1.2 kΩ pull-up and pull-down resistors( R17 and R14). There is also a built in 120 Ω termination resistor (R21). These resistors are located on the PCB behind the cover. Termination is switchable using DIP Switch Position 3. To enable the termination, set switch 3 to ON "Termination IN". To disable the termination, set switch 3 to OFF "Termination OUT".

It is possible to use different value resistors by removing the surface mount components and placing through-hole resistors (R16, R13, and R19) in the space provided. The surface mount components are located directly opposite of the through-hole pads that are visible.



**Figure 4-6 Through-hole Resistor Pads**

**4.1.7 FAULT OUTPUT**

The radio modem has a sourcing (PNP) 50 mA output that is used as a fault indicator. This output is activated when the received signal strength drops below a critical level. To use this function, the RSSI indicator must be set to continuously update. This is accomplished by setting the RP-RSSI PWM Timer to FF in the diagnostics section of the advanced modem settings tab. See figures 4-7 and 4-8. Figure 4-9 shows the wiring connections.

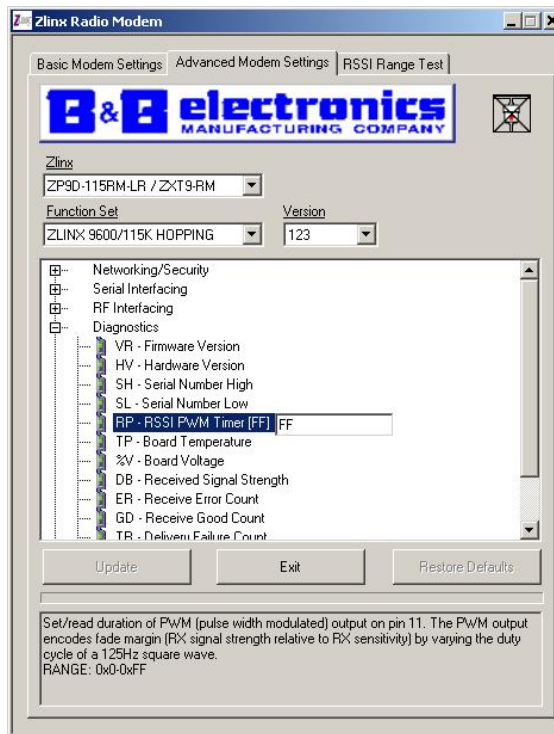

**Figure 4-7 RP – RSSI PWM Timer, ZXT9-RM**

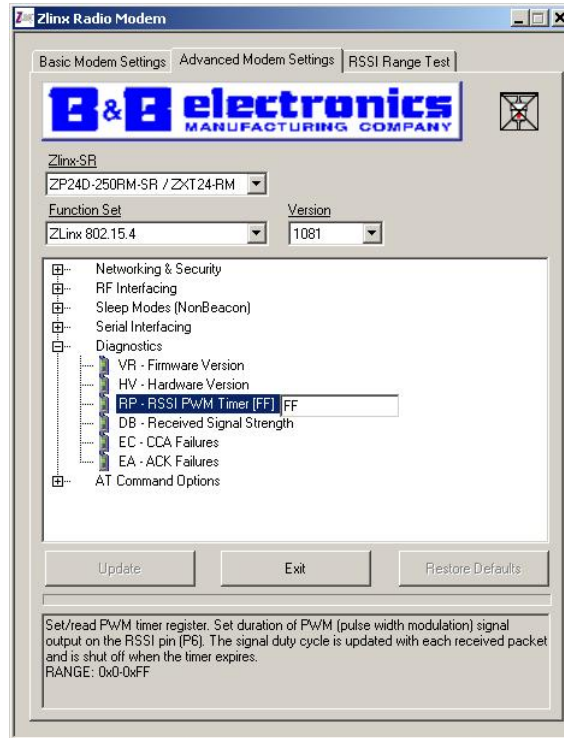

**Figure 4-8 RP – RSSI PWM Timer, ZXT9-RM**

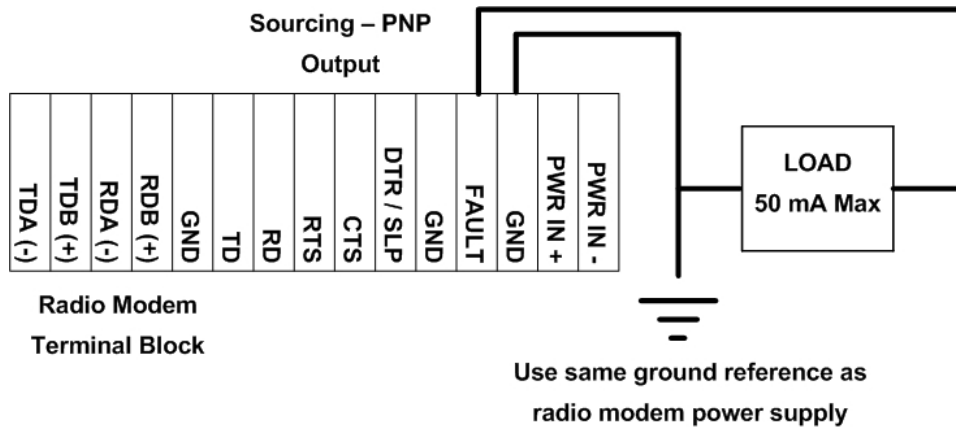

**Figure 4-9 Fault Output Wiring**

## 5 - SOFTWARE INSTALLATION

### 5.1 ZLINX<sup>®</sup> MANAGER SOFTWARE OVERVIEW

#### 5.1.1 COMPUTER SYSTEM REQUIREMENTS

The Zlinx Manager software requires the following computer hardware and operating systems:

- A PC with a USB port
- One of the following operating systems installed
- Windows XP (32 or 64 bit)
- Windows Vista (32 bit or 64 bit)
- Windows 7 (32 or 64 bit)
- Windows 8 or 8.1 (32 or 64 bit)
- Windows 10 (32 or 64 bit)

### 5.2 INSTALLING ZLINX<sup>®</sup> MANAGER SOFTWARE

#### 5.2.1 INSTALLING ZLINX<sup>®</sup> MANAGER SOFTWARE

The manager software is contained on the CD ROM which was included with your radio modem. Insert the CD into your CD drive. The installation process should start automatically. If it does not, navigate to the CD drive in Windows Explorer and double click the executable file on the CD.

1. The Welcome Screen will be displayed.



Figure 5-1 Installation Welcome Screen

2. Click the **Next** Button. The software release note screen will be displayed. This screen displays important information about the latest release of the manager software.

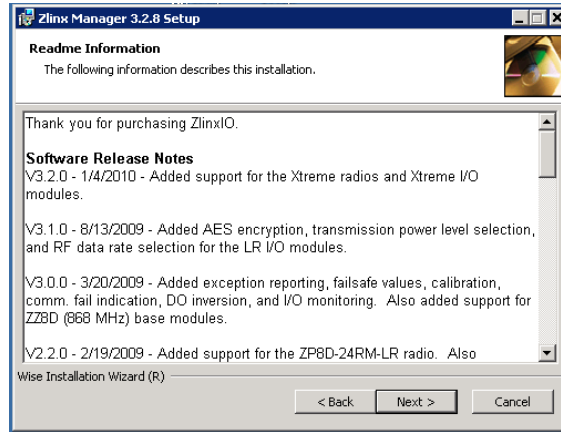

**Figure 5-2 Software Release Notes Screen**

3. Click the **Next** button. The software license agreement screen will be displayed. Accept the **License Agreement** and click the **Next** button.

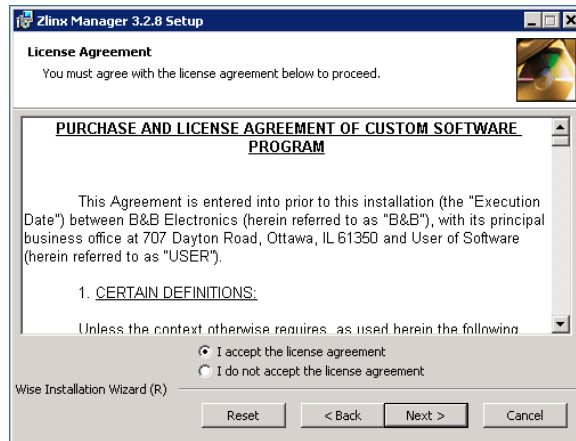

**Figure 5-3 License Agreement Screen**

4. The **User Information** screen will be displayed. Fill in the required information and click the **Next** button.

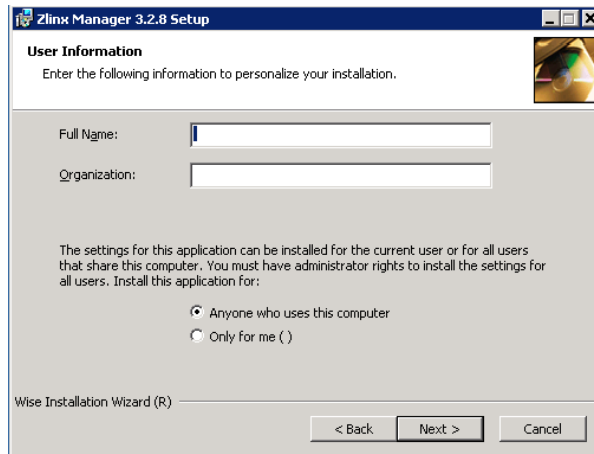

**Figure 5-4 User Information Screen**

- The **Destination Folder** screen will be displayed. You can accept the default location (C:\Program Files\B+B SmartWorx) or choose your own location by clicking on the **Browse** Button. When your selection is complete, click on the **Next** Button.

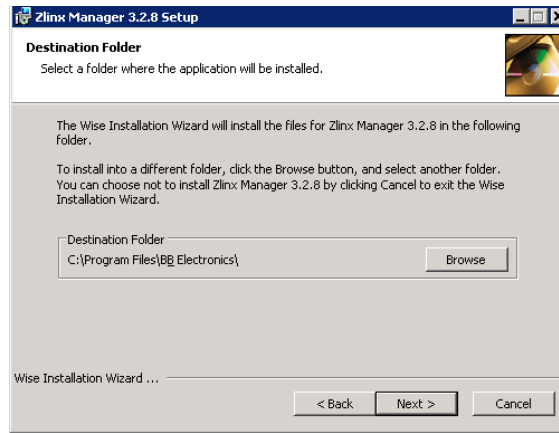

**Figure 5-5 Destination Folder Screen**

- The **Ready to Install Application** screen will be displayed. Click the **Next** button when ready.

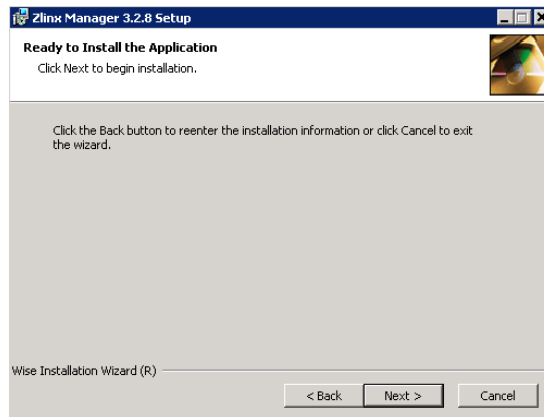

**Figure 5-6 Ready to Install Application Screen**

- The Installation Wizard will start to copy files to your system. It may take a few minutes to copy all of the required files. The status bar will show the progress of the installation.

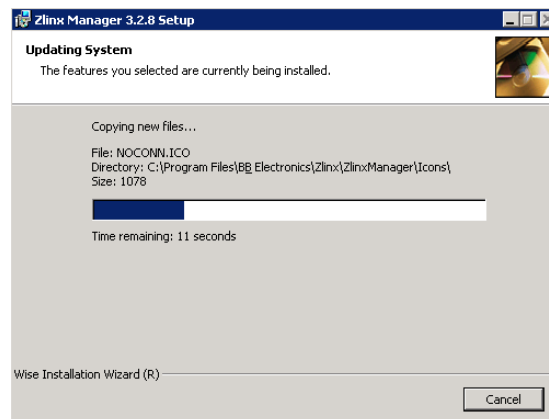

**Figure 5-7 Installation Progress Screen**

- The Installation Complete screen will be displayed. Click the **Finish** button.

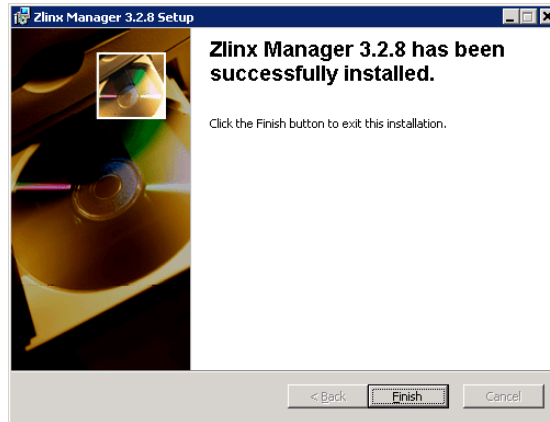

Figure 5-8 Installation Progress Screen

## 5.2.2 INSTALLING USB DRIVERS

- The USB driver is installed with the manager software. You should not connect to the USB port before installing the manager software.
- If the found new hardware wizard appears after attaching the cable, follow the wizard. The drivers are located in the “USB Drivers” folder on the CD.

## 5.3 STARTING ZLINX<sup>®</sup> MANAGER SOFTWARE

### 5.3.1 STARTING THE MANAGER SOFTWARE

Double-click on the Zlinx Desktop Icon or press the start button and locate the software. The manager software will start. Select the **Radio Modem** option on the startup screen.



Figure 5-9 Zlinx Selection Screen

The **Radio Modem Configuration** screen will be displayed. This screen allows you to configure your radio modem directly or off-line, update the firmware, return to the initial screen or exit.



Figure 5-10 Radio Modem Configuration Screen

### 5.3.2 RADIO MODEM CONFIGURATION SCREEN

The **Radio Modem Configuration** screen is used to configure your radio modem

The first screen contains options that configure your PC COM port to communicate with the radio modem.

Use the pull-down menu items to select the following options.

**Model:** This allows you to specify the model number you are trying to connect to.

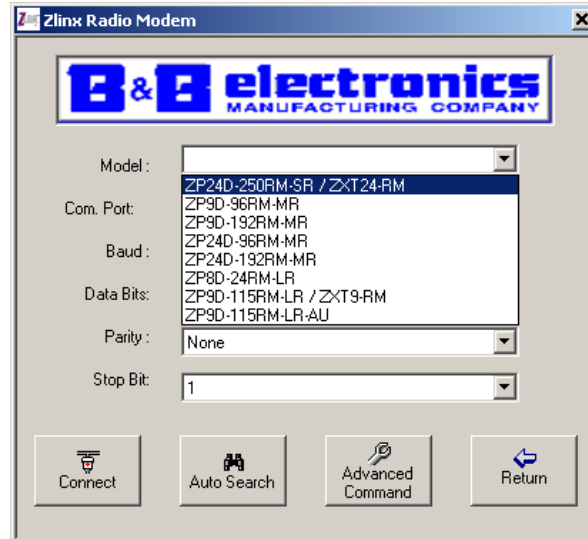

Figure 5-11 Model Number Selection Pull-down Menu

**COM Port:** This allows you to specify the COM Port your PC is configured to use to connect to the radio modem. COM1 through COM16 may be specified.

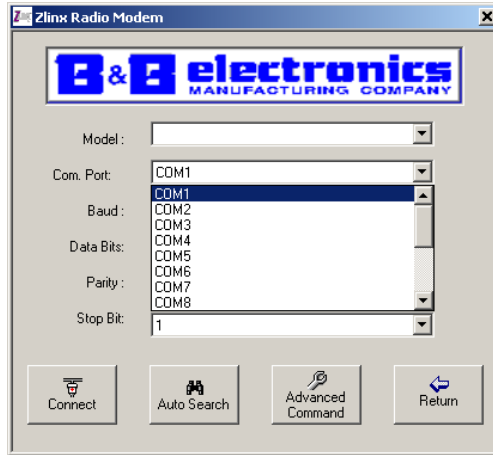

Figure 5-12 COM Port Pull-down Menu

**Baud Rate:** This allows you to specify the COM Port baud rate. Choices are from 1200 to 230400 baud.

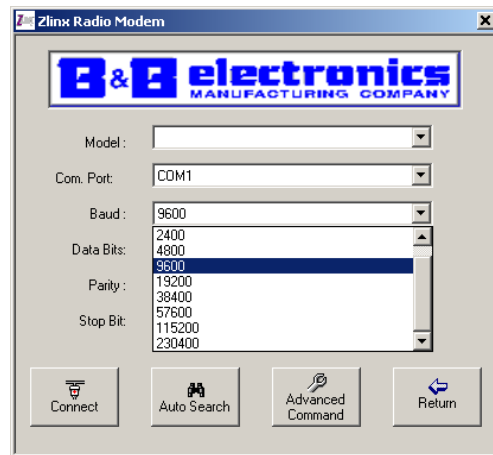

Figure 5-13 Baud Rate Pull-down Menu

**Data Bits:** This allows you to select the number of data bits. Choices are from five to eight.

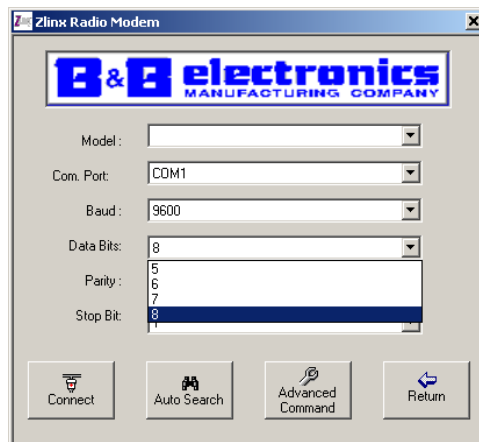

Figure 5-14 Data Bits Pull-down Menu

The number of data bits in each character can be 5 (for Baudot code), 6 (rarely used), 7 (for true ASCII), or 8 (for any kind of data, as this matches the size of a byte). Eight data bits are almost universally used in newer applications. 5 or 7 bits generally only make sense with older equipment.

**Parity:** This allows you to select the parity. Choices are None, Odd, Even, Mark, Space, or 9 Bit Passing.

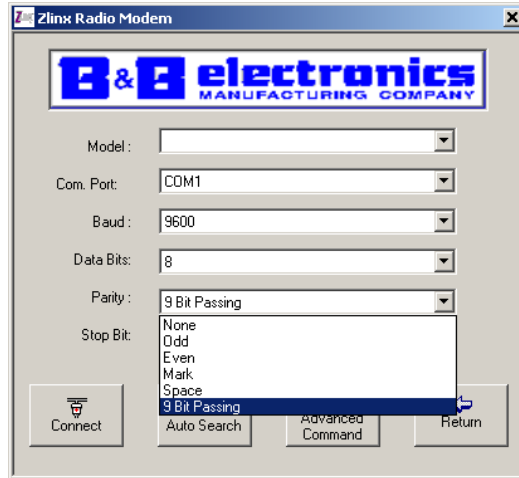

Figure 5-15 Parity Pull-down Menu

Parity is a method of detecting errors in transmission. When parity is used with a serial port, an extra data bit is sent with each data character, arranged so that the number of 1 bits in each character, including the parity bit, is always odd or always even. If a byte is received with the wrong number of 1's, then it must have been corrupted. However, an even number of errors can pass the parity check.

The parity bit in each character can be set to none (N), odd (O), even (E), mark (M), or space (S). **None** means that no parity bit is sent at all. **Mark** parity means that the parity bit is always set to the mark signal condition (logical 1) and, likewise, **Space** parity always sends the parity bit in the space signal condition. Some uncommon applications that use the 9th (parity) bit for some form of addressing or special signaling. Mark or space parity is also uncommon, as it adds no error detection information. **Odd** parity is more common than **Even**, since it ensures that at least one state transition occurs in each character, which makes it more reliable. The most common parity setting, however, is "none", with error detection handled by a communication protocol.

**Stop Bits:** This allows you to select the number of Stop Bits. Choices are 1, 1.5 and 2.

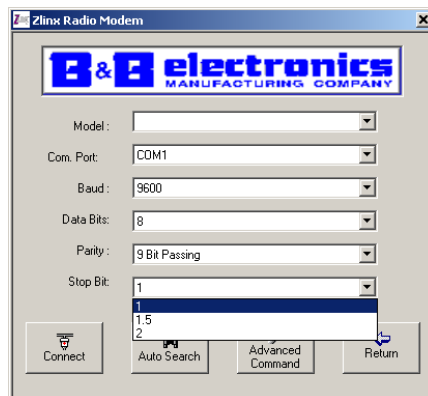

Figure 5-16 Stop Bits Down Menu

Stop bits sent at the end of every character allow the receiving signal hardware to detect the end of a character and to resynchronize with the character stream. Electronic devices usually use one stop bit. If slow devices are used, one-and-one-half or two stop bits are required.

**Connect Button** connects to a radio modem using the configuration selected using the pull-down menu items.

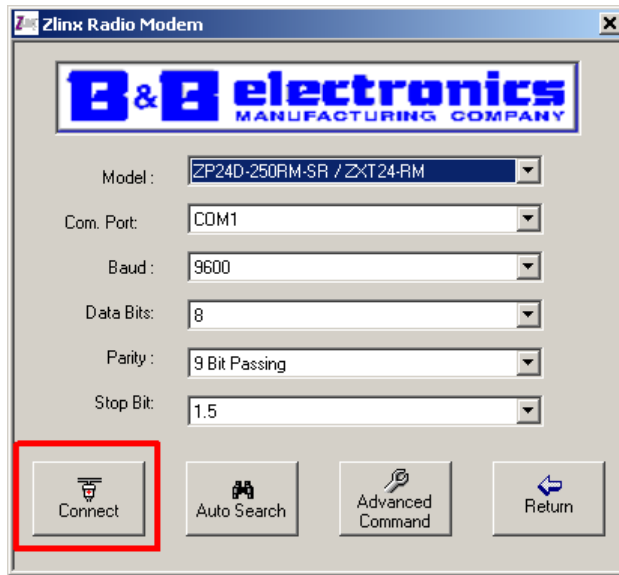

Figure 5-17 Connect Button

When you press the **Connect** button, the manager software will attempt to connect to the radio modem using the settings selected with the pull-down options. The **Radio Modem Search** screen will be displayed. If the settings are correct and a Radio Modem is found, click the **OK** button, the **Radio Modem Settings** screen will be displayed.

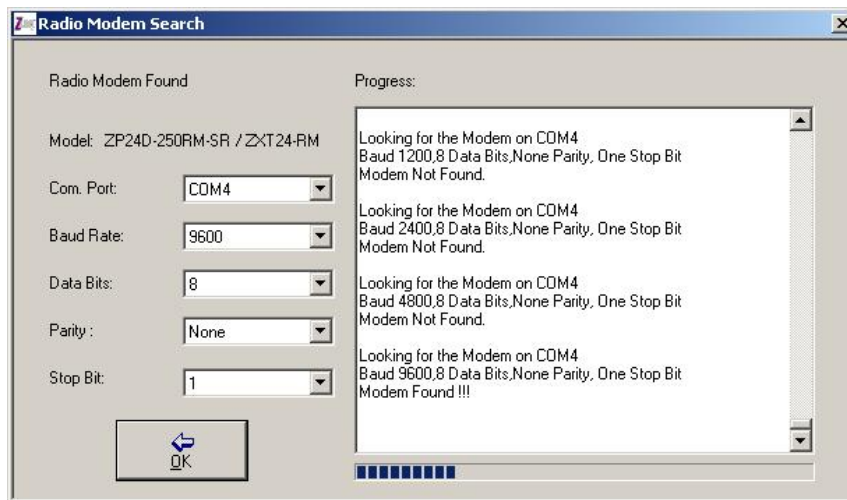

Figure 5-18 Radio Modem Search Screen

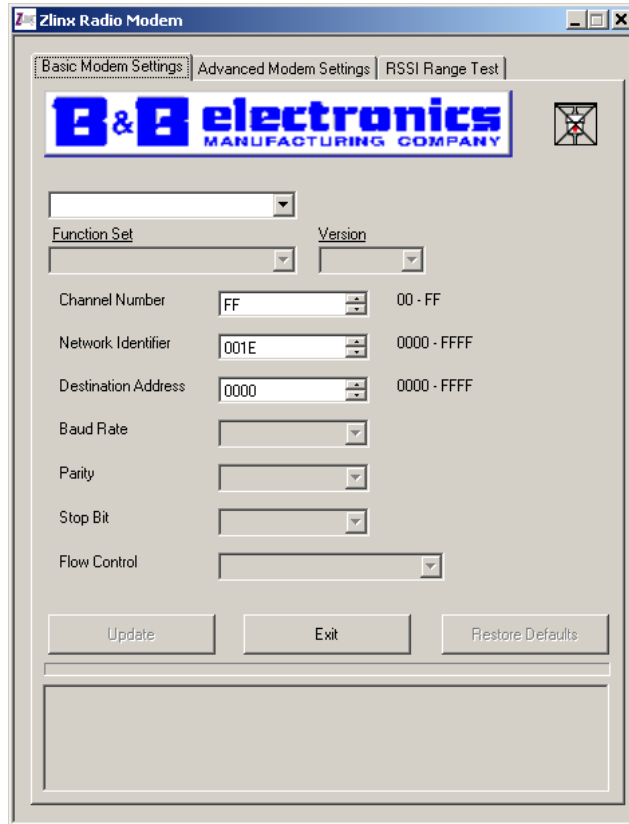

Figure 5-19 Radio Modem Settings screen

If settings are not correct, an error screen will be displayed. Correct the COM Port Settings or use the **Auto Search** button.

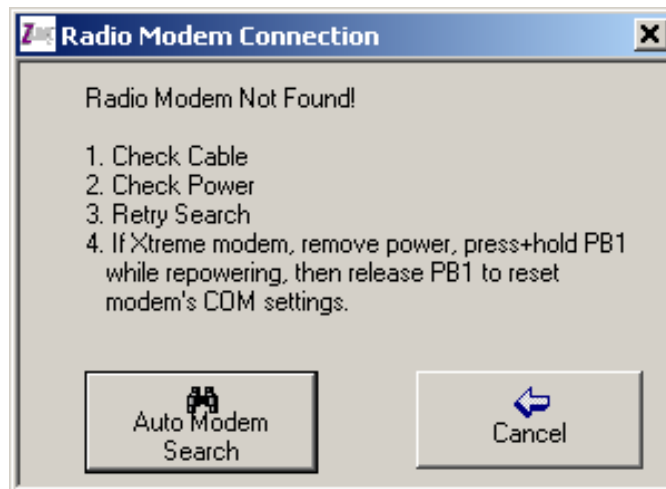

Figure 5-20 Radio Modem Not Found screen

**Auto Search Button:** The **Auto Search** button will search for Zlinx devices connected to a COM port and connect. This is useful if you do not know the radio modem configuration.

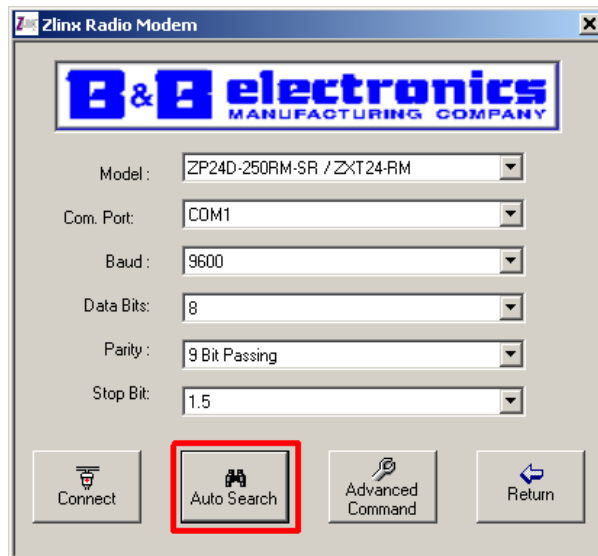

Figure 5-21 Auto Search Button

Your PC will attempt to connect to any radio modem connected. The radio modem search screen will be displayed (figure 5-18). Click the **OK** button and the manager software will display the **Radio Modem Settings** screen (figure 5-19). If a modem is not attached, the **Radio Modem Not Found** screen will be displayed (figure 5-20).

**Advanced Command Button** is used to select the character sequence to enter command mode as well as required "quiet times" before and after the command sequence. It is recommended that you do not change these values.

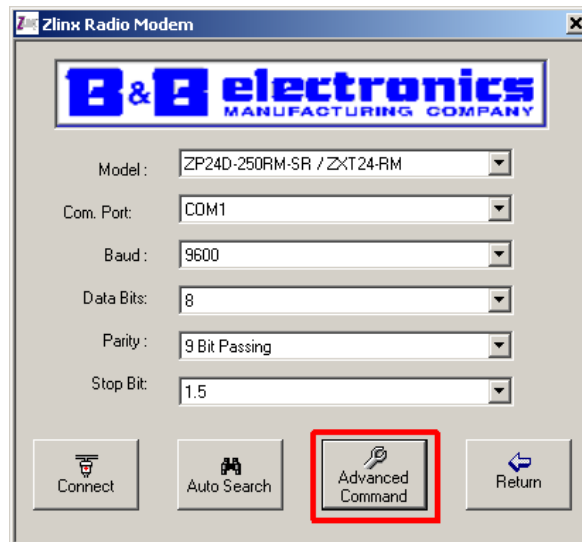

Figure 5-22 Advanced Command Button

Pressing the **Advanced Command** button will bring up the following screen.

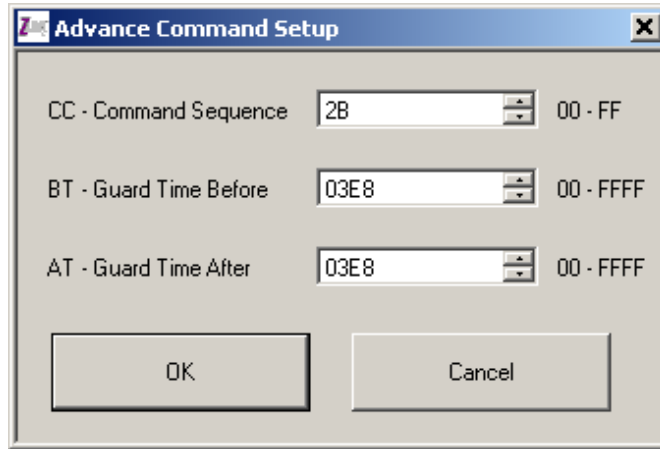

Figure 5-23 Advanced Command Button

**CC – Command Sequence:** The CC command is used to set/read the ASCII character used between guard times of the AT Command Mode Sequence (BT + CC + AT). This sequence enters the modem into AT Command Mode so that data entering the modem (from the host) is recognized as a command instead of payload. The default value of 2B is equivalent to “+” in ASCII.

**BT – Guard Time Before & AT Guard Time After:** Sets the required period of silence before, after and between the Command Mode Characters of the Command Mode Sequence (GT + CC + GT). The period of silence is used to prevent inadvertent entrance into AT Command Mode.

**Return Button:** The Return button is used to return to the manager main screen.

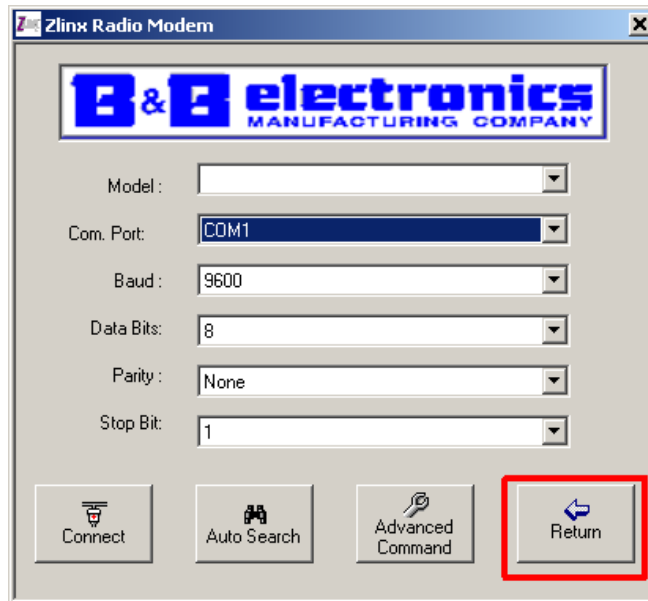

Figure 5-24 Return Button

5.3.2.1 RADIO MODEM SETTINGS (ZXT9-RM)

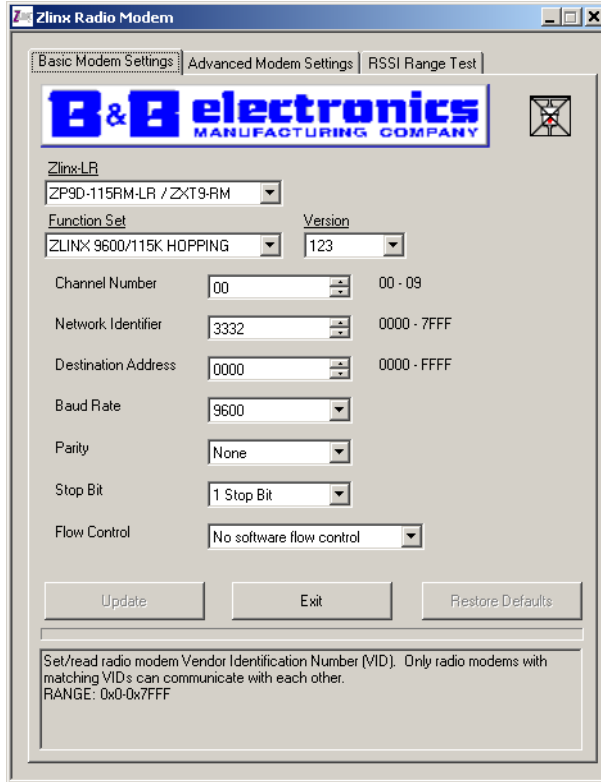

Figure 5-24 Basic Radio Modem Settings (ZXT9-RM)

**Basic Modem Settings Tab:**

The **Basic Modem Settings** tab is used to configure the following parameters:

**Model Number:** Displays the model number of the radio modem.

**Function Set:** Dependent on firmware.

**Version:** Dependent on firmware.

**Channel Number:** Set/read spread spectrum channel on which modem communicates. Separate channels minimize interference between multiple sets of modems operating in the same vicinity. The range is: 0x0 to 0x9. Default is 00.

**Network Identifier:** Set/read radio modem Vendor Identification Number (VID). Only radio modems with matching VID's can communicate with each other.

The range is 0x0-0x7FFF. Default is 3332.

**Destination Address:** Set/read module's destination address. The range is 0x0-0xFFFF. Default is FFF7.

**Baud Rate:** Select serial interface rate (speed for data transfer between radio modem and host). Serial data rate does not have to match the RF data rate which is adjustable using the BR command on the Advanced Tab. If the serial data rate is set higher than the RF data rate, CTS may need to be observed to prevent buffer overrun. Range is 1200 to 230400 baud. Default is 9600.

**Parity:** Refer to section 5.3.2

**Stop Bit:** Refer to section 5.3.2

**Flow Control:** Select flow control options. Enables software flow control (XON/XOFF) between radio modem and host. Choices are Software Flow Control or No Flow Software Flow Control. Default is No Software Flow Control.

Click **Update** to save changed settings. Click **Restore Defaults** to restore the default settings. Click **Exit** to exit.

**Advanced Modem Settings Tab:**

The **Advanced Modem Settings** tab is used to configure Networking/Security, Serial Interfacing, RF Interfacing, Diagnostics, Sleep (Low Power), and Command Mode features.

Click **Update** to save changed settings. Click **Restore Defaults** to restore the default settings. Click **Exit** to exit.



**Figure 5-25 Advanced Radio Modem Settings (ZXT9-RM)**

**Networking and Security:** Used to configure addressing and security options.

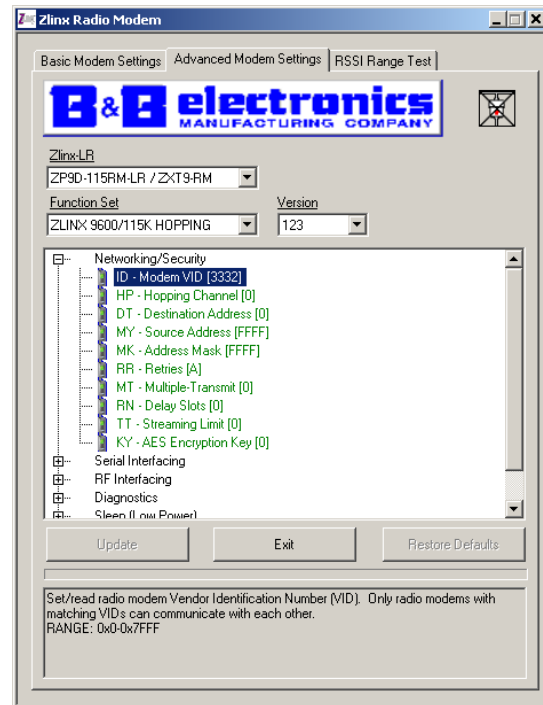

**Figure 5-26 Networking and Security Options (ZXT9-RM)**

**ID – Modem VID:** Set on the Basic Tab. Set/read radio modem Vendor Identification Number (VID). Only radio modems with matching VIDs can communicate with each other.

The range is 0x0 to 0x7FFF

**HP – Hopping Channel:** Set/read spread spectrum channel on which modem communicates. Separate channels minimize interference between multiple sets of modems operating in the same vicinity.

The range is 0x0 to 0x9

**DT – Destination Address:** Set/read module's destination address.

The range is 0x0 to 0xFFFF

**MY – Source Address:** Set/read module's source address. If set to 0xFFFF, then the DT address is used for both source and destination addresses.

The range is 0x0 to 0xFFFF

**MK – Address Mask:** Set/read the module address mask for configuration of local and global address spaces.

The range is 0x0 to 0xFFFF

**RR – Retries:** Set/read maximum number of RF packet delivery attempts. If RR is non-zero and MT is zero, packets sent from the radio will request an acknowledgement, and can be resent up to RR times if no acknowledgements are received.

The range is 0x0 to 0xFF

**MT – Multiple Transmit:** Set/read number or retransmissions. If MT parameter is a non-zero value, RR is ignored and all packets are sent MT+1 times, without any delay between the transmissions.

RANGE: 0x0 to 0xFF

**RN – Delay Slots:** Set/read the maximum number of delay slots used for random back-off algorithm after transmission failure. A delay slot is 5 msec when BR=1 and 54 msec when BR=0.

The range is 0x0 to 0xFF

**TT – Streaming Limit:** Set/read maximum number of continuous bytes transmitted by one module before forcing a delay that allows other modules to transmit. 0 = disabled.

The range is 0x0 to 0xFFFF

**KY – AES Encryption Key:** Set/read AES encryption settings. Set 256-bit key (64 hex digits) on multiple radios for encrypted RF communication. Set to '0' to disable encryption. Reading parameter returns a '0' (encryption disabled) or '1' (enabled). The key cannot be read for security reasons. When this option is highlighted, a SET box will appear on the right. Clicking this box will bring up the AES encryption entry screen.

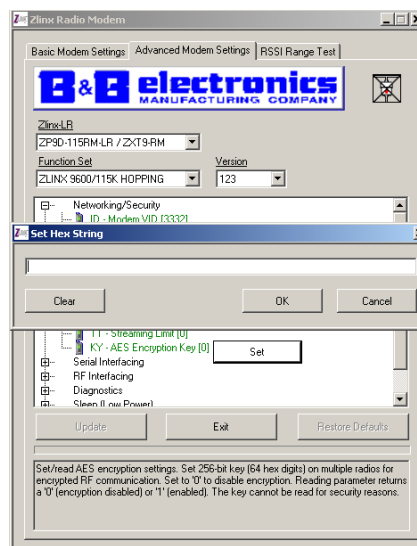

Figure 5-27 KY– AES Encryption Entry Screen (ZXT9-RM)

**Serial Interfacing:** Used to change modem interfacing options.

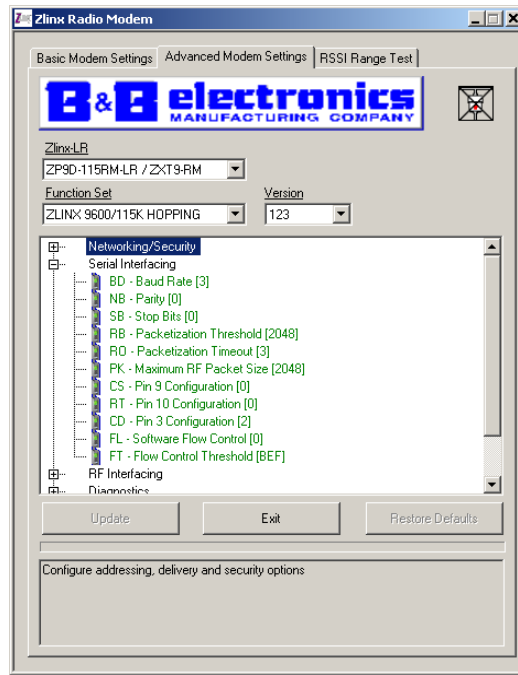

Figure 5-28 Serial Interfacing (ZXT9-RM)

**BD – Baud Rate:** Select serial interface rate (speed for data transfer between radio modem and host). Serial data rate does not have to match the RF data rate which is adjustable using the BR command. If the serial data rate is set higher than the RF data rate, CTS may need to be observed to prevent DI buffer overrun. This is a pull-down option. Selections are:

- 0 – 1200
- 1 – 2400
- 2 – 4800
- 3 – 9600
- 4 – 19200
- 5 – 38400
- 6 – 57600
- 7 – 115200
- 8 – 230400

**NB – Parity:** Select parity settings for UART communications. This is a pull-down option. Selections are:

- 0 – None
- 1 – Even
- 2 – Odd
- 3 – Mark
- 4 – Space

**SB – Stop Bits:** Select number of stop bits used for UART communications. This is a pull-down option. Selections are:

- 0 – 1 Stop Bit
- 1 – 2 Stop Bits

**RB – Packetization Threshold:** Set/read character threshold. RF transmission is begun after receiving RB bytes, or after receiving at least 1 byte and seeing RO character times of silence on the UART.

**RO – Packetization Timeout:** RF transmission begins after receiving RB bytes, or after receiving at least 1 byte and seeing RO character times of silence on the UART. If RO=0, then RB bytes must be received before beginning transmission.

Range: 0x0 to 0xFFFF.

**PK – Maximum RF Packet Size:** Set/read maximum RF packet size. Must be 256 (0x100) or less for 9600 baud RF rate (BR=0), and 2048 (0x800) or less for 115200 baud RF rate (BR=1).

Range is 0x1 to 0x800.

**CS – Pin 9 Configuration:** Select behavior of serial Terminal Block position 9 (CTS). This is a pull-down option. Selections are:

- 0 – CTS Flow Control
- 1 – RS-485 Enable Low
- 2 – GP01 Static High
- 3 – RS-485 Enable High
- 4 – GP01 Static Low

**RT – Pin 10 Configuration:** Select function for serial Terminal Block position 8 (RTS). This is a pull-down option. Selections are:

- 0 – Unused
- 1 – Binary Command Indicator
- 2 – RTS Flow Control

**FL – Software Flow Control:** Select flow control options. Enables software flow control (XON/XOFF) between radio modem and host. This is a pull-down option.

- 0 – No Software Flow Control
- 1 – Use Software Flow Control

**FT – Flow Control Threshold:** Set/read the flow control threshold. De-assert CTS and/or send XOFF when FT bytes are in the UART receive buffer. The range is 0x0 to 0xFFFF.

**RF Interfacing** - Change RF interface options.

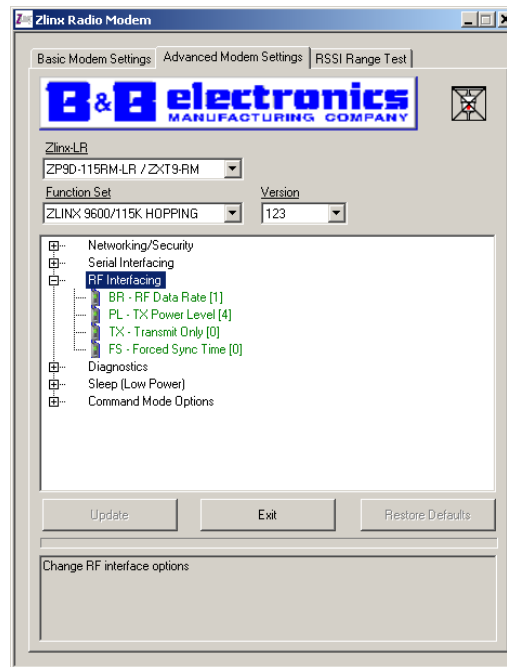

**Figure 5-29 RF Interfacing (ZXT9-RM)**

**BR – RF Data Rate:** Select RF data rate (over-the-air transmission rate). This is a pull-down option. Selections are:

- 0 – 9600 bps
- 1 – 115200 bps

Selecting 9600 can extend the radio modem's range, but limit its throughput. Selecting 115200 can maximize the throughput, but the range will be limited.

**PL – TX Power Level:** Select transmit power level. This is a pull-down option. Selections are:

- 0 – 1 mW
- 1 – 10 mW
- 2 – 100 mW
- 3 – 500 mW
- 4 – 1 Watt

**TX – Transmit Only:** Select TX/RX or TX Only. This is a pull-down option. Selections are:

- 0 – Transmit and Receive
- 1 – Transmit Only

**FS – Forced Sync Time:** Set/read forced re-sync period. Normally only the first packet of a transmission event contains the sync preamble. This command allows forced periodic sync preambles during long transmission events. Zero disables this feature. The range is 0x0 to 0xFFFF.

**Diagnostics:** Access diagnostic parameters.

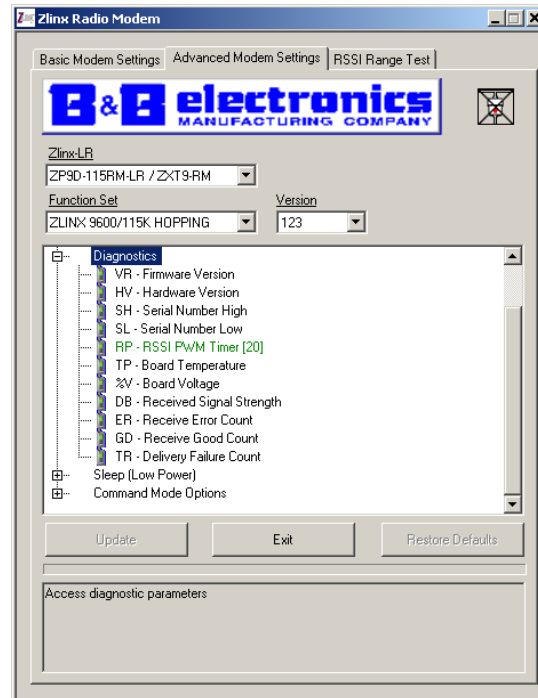

Figure 5-30 Diagnostics (ZXT9-RM)

**VR – Firmware Version:** Read module firmware version number. Read-only function.

**HV – Hardware Version:** Read module hardware version number. Read-only function.

**SH – Serial Number High:** Read high 16 bits of 32 bit unique serial number. Read-only function.

**SL – Serial Number Low:** Read low 16 bits of 32 bit unique serial number. Read-only function.

**RP – RSSI PWM Timer:** Set/read duration of PWM (pulse width modulated) output. The PWM output encodes fade margin (RX signal strength relative to RX sensitivity) by varying the duty cycle of a 125Hz square wave. The range is 0x0 to 0xFF

**TP – Board Temperature:** Read current temperature of module in degrees Celsius (8-bit twos-complement, eg. 26C = 0x1A, -10C = 0xF6). Read-only function.

**%V – Board Voltage:** Read supply voltage to module (VCC) multiplied by 65536 (eg. 5.02V = 5.02\*65536 = 0x5051F, maximum of 5 digits returned). Read-only function.

**DB – Receive Signal Strength:** Read signal level of last good packet received (RSSI) in dB (reports absolute value, eg. -88dBm = 0x58, accurate between -40 dBm to RX sensitivity). Read-only function.

**ER – Receive Error Count:** Set/read number of RF Packets rejected because of bit errors in packet. Read-only function.

**GD – Receive Good Count:** Set/read number of RF Packets successfully received. Read-only function.

**TR – Delivery FailureCount:** Read number of RF packets sent where retries expire with no ACK received (when RR>0). Read-only function.

**Sleep – Low Power:** Radio modem can be put into Sleep Mode to reduce the amount of power consumed.

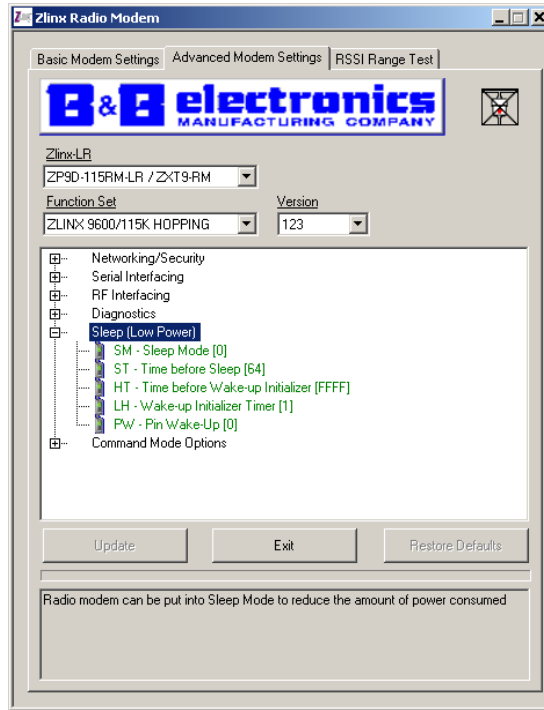

**Figure 5-31 Sleep (Low Power) (ZXT9-RM)**

**SM – Sleep Mode:** Select Sleep Mode option. Lowest power is achieved using the SHDN signal. Cyclic sleep can be used to trade idle current consumption for transmission latency. This is a pull-down option. Selections are:

- 0 – No Sleep
- 1 – Pin Sleep (DTR Pin used for this feature)
- 2 – Serial Port Sleep
- 3 – Reserved
- 4 – Cycle 1 Second
- 5 – Cycle 2 Seconds
- 6 – Cycle 4 Seconds
- 7 – Cycle 8 Seconds
- 8 – Cycle 16 Seconds

**ST – Time Before Sleep:** Set/read time period of inactivity (no serial or RF data is sent or received) before activating Sleep Mode - Only valid with Cyclic and Serial Port Sleep settings. The range is 0x10 to 0xFFFF.

**HT – Time Before Wakeup Initializer:** Set/read time of inactivity (no serial or RF data is sent or received) before a Wake-up Initializer is sent. HT should be set shorter than ST of all remote radios. The range is 0x0 to 0xFFFF.

**LH – Wake-up Initializer Timer:** Set/read time of the Wake-up Initializer used to wake remote radios that are in cyclic sleep mode. Time of Wake-up Initializer should be longer than that of the remotes radio's cyclic sleep cycle (SM 4-8). The range is 0x0 to 0xFF.

**PW – Pin Wake-up:** Select pin wake-up options. When PW=1, pin wake-up from Cyclic Sleep Mode is enabled. This is a pull-down option. Selections are:

- 0 – Disable
- 1 – Enable

**Command Mode Options** – Commands that change AT command mode behavior.

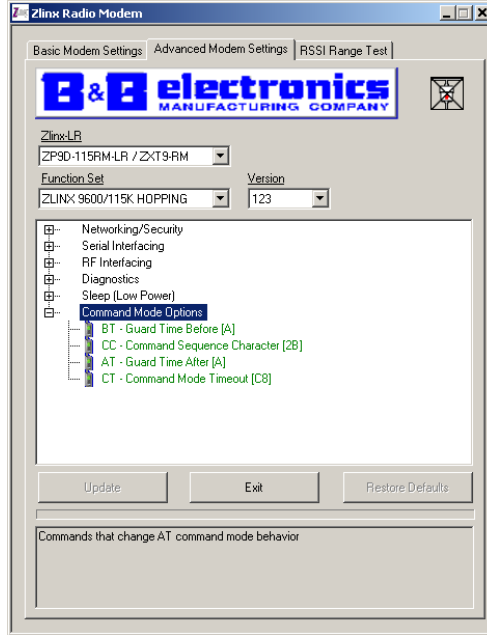

Figure 5-32 Command Mode Options (ZXT9-RM)

**BT – Guard Time Before:** Set/read required DI pin silent time before the Command Sequence Characters of the Command Mode Sequence (BT+CC\_AT). The DI silent time is used to prevent inadvertent entrance into Command Mode.

The range is 0x0 to 0xFFFF.

**CC – Command Sequence Character:** Set/read ASCII character to be used between Guard Times of the AT Command Mode Sequence (BT+CC+AT). The AT Command Mode Sequence causes the radio modem to enter Command Mode (from Idle Mode).

The range is 0x20 to 0x7F.

**AT – Guard Time After:** Set/read required DI pin silent time after the Command Sequence Characters of the AT Command Mode Sequence (BT+CC+AT). The DI silent time is used to prevent inadvertent entrance into Command Mode.

The range is 0x2 to 0x7FFC.

**CT – Command Mode Timeout:** Set/read time period of inactivity (no valid commands received) after which the radio modem automatically exits from Command Mode and returns to Idle Mode.

The range is 0x2 to 0xFFFF.

## 5.3.2.2 RADIO MODEM SETTINGS (ZXT24-RM)

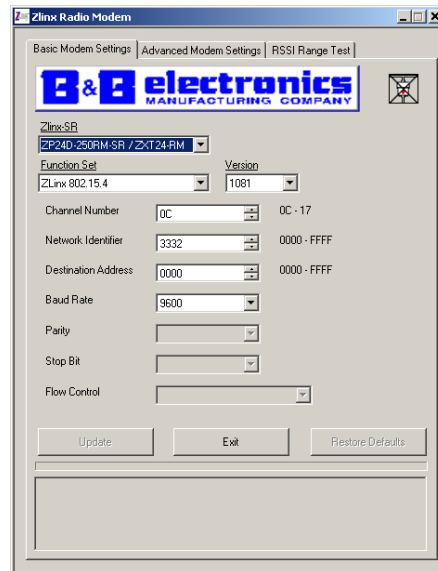

Figure 5-33 Basic Radio Modem Settings (ZXT24-RM)

**Basic Modem Settings Tab** is used to configure the following parameters:

**Model Number:** Displays the radio modem model number.

**Function Set:** Functions supported by firmware.

**Version:** Firmware version.

**Channel Number:** Set/read the channel number (uses 802.15.4 channel numbers).

The range is 0xC to 0x17

**Network Identifier:** Set the PAN (Personal Area Network) ID. Use 0xFFFF to send message to all PAN's.

The range is 0x0 to 0xFFFF.

**Destination Address:** Set/read the lower 32 bits of the 64 bit destination address. Set the DH register to zero and DL less than 0xFFFF to transmit using a 16 bit address. 0x000000000000FFFF is the broadcast address for the PAN.

The range is 0x0-0xFFFFFFFF.

**Baud Rate:** Set/read the serial interface baud rate for communication between modem serial port and host. Request non-standard baud rates with values above 0x80 using a terminal window. Read BD register to find actual baud rate achieved

**Parity:** Not Selectable

**Stop Bit:** Not Selectable

**Flow Control:** Not Selectable

Click **Update** to save changed settings. Click **Restore Defaults** to restore the default settings. Click **Exit** to exit.

**Advanced Modem Settings Tab:**

The Advanced Settings tab is used to configure Networking/Security, RF Interfacing, Sleep Modes (Non Beacon), Serial Interfacing, Diagnostics, and AT Command Mode features.

Click Update to save changed settings. Click **Restore Defaults** to restore the default settings. Click **Exit** to exit.

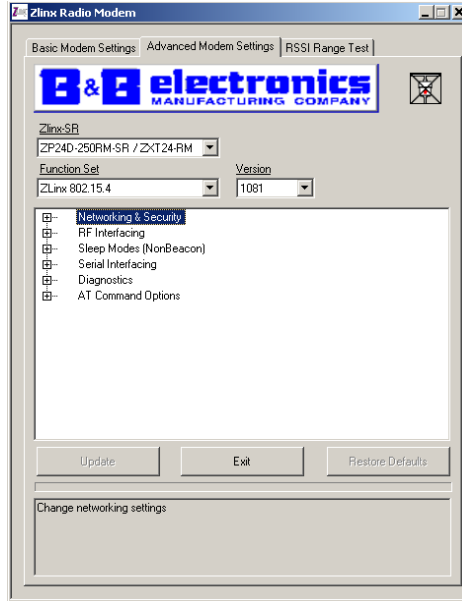

**Figure 5-34 Advanced Radio Modem Settings (ZXT24-RM)**

**Networking and Security:** Used to configure addressing and security options.

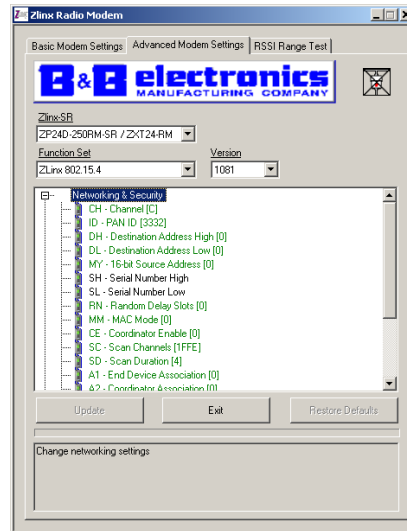

**Figure 5-35 Network and Security Settings (ZXT24-RM)**

**Networking and Security:** Set/read the channel number (uses 802.15.4 channel numbers).

The range is 0xC to 0x17.

**ID – PAN ID:** Set the PAN (Personal Area Network) ID. Use 0xFFFF to send message to all PAN's.

The range is 0x0 to 0xFFFF.

**DH – Destination Address High:** Set/read the upper 32 bits of the 64 bit destination address. Set the DH register to zero and DL less than 0xFFFF to transmit using a 16-bit address. 0x000000000000FFFF is the broadcast address for the PAN.

The range is 0x0 to 0xFFFFFFFF.

**DL – Destination Address Low:** Set/read the lower 32 bits of the 64 bit destination address. Set the DH register to zero and DL less than 0xFFFF to transmit using a 16-bit address. 0x000000000000FFFF is the broadcast address for PAN.

The range is 0x0 to 0xFFFFFFFF

**MY – 16 Bit Source Address:** Set/read the 16-bit source address for the modem. Set MY = 0xFFFF to disable reception of packets with 16-bit addresses. 64-bit source address is the serial number and is always enabled.

The range is 0x0 to 0xFFFF.

**RM – Random Delay Slots:** Set/Read the minimum value of the back-off exponent in the CSMA-CA algorithm that is used for collision avoidance. If RN=0, collision avoidance is disabled during the first iteration of the algorithm (802.15.4 - macMinBE).

The range is 0x0 to 0x3.

**MM – Mack Code:** Set/Read MAC Mode value. MAC Mode enables/disables the use of a the header in the 802.15.4 RF packet. When Mode 0 is enabled (MM=0), duplicate packet detection is enabled as well as certain AT commands. Modes 1 and 2 are strict 802.15.4 modes. This is a pull-down option. Selections are:

0 – 802.15.4 + MaxStream<sup>®</sup> Header

1 – 802.15.4 No ACKS's

2 – 802.15.4 With ACK's

**CE – Coordinator Enable:** Set/Read the coordinator setting. This is a pull-down option. Selections are:

0 - End Device

1 - Coordinator

**SC – Scan Channels:** Read/set list of channels to scan for Active and Energy Scans as bitfield. Scans may be initiated by ATAS, ATED commands and during End Device Association and Coordinator startup: Bit 15 - Ch. 0x1A . . . Bit 0 -Ch. 0x0B (bits 15, 14 and 0 not available on ZLinx).

The range is 0x0 to 0xFFFF.

**SD – Scan Duration:** Set read the Scan duration exponent. The exponent configures the duration of the active scan during association. Set End Device SD = BE of beaconing coordinator. Scan Time =  $N * (2 \wedge SD) * 15.36\text{ms}$ . N=# channels: ZLinx = 16, ZLinx/Pro = 13.

The range is 0x0 to 0x0F.

**A1 – End Device Association:** Set/read End Device association options. Options enabled when bits are set: bit3 - Poll coordinator on pin wake, bit2 - Auto Associate, bit1 - Allow Channel reassignment, bit0 - Allow PanId reassignment. This is a pull-down option. Selections are:

0 – 0000b

1 – 0001b

2 – 0010b

3 – 0011b

4 – 0100b

- 5 – 0101b
- 6 – 0110b
- 7 – 0111b
- 8 – 1000b
- 9 – 1001b
- 10 – 1010b
- 11 – 1011b
- 12 – 1100b
- 13 – 1101b
- 14 – 1110b
- 15 – 1111b

**A2 – Coordinator Association:** Set/read Coordinator association options. Options enabled when bits are set: bit2 - Allow Association, bit1 - Allow Channel reassignment, bit0 - Allow PanId reassignment. This is a pull-down option. Selections are:

- 0 – 000b
- 1 – 001b
- 2 – 010b
- 3 – 011b
- 4 – 100b
- 5 – 101b
- 6 – 110b
- 7 – 111b

**RF Interfacing:** Used to change RF interface options.

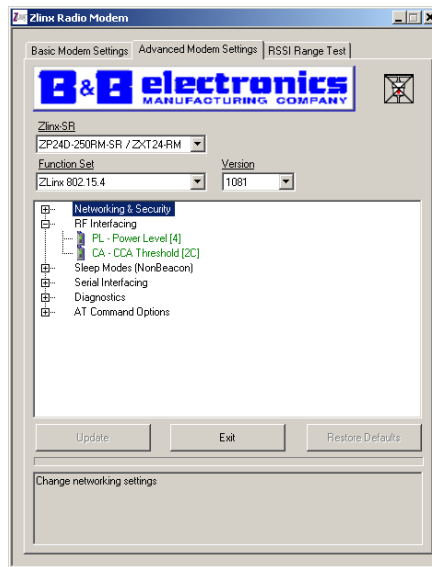

**Figure 5-36 RF Interfacing (ZXT24-RM)**

**PL – Power Level:** Select/Read transmitter output power. This is a pull-down option. Selections are:

- 0 – 10dBm (Lowest)
- 1 – 12dBm (Low)
- 2 – 14dBm (Medium)
- 3 – 16dBm (High)
- 4 – 18dBm (Highest)

**CA – CCA Threshold:** Set/read the Clear Channel Assessment (CCA) threshold. If the modem detects energy above the CCA Threshold, it will not transmit. The CCA parameter is measured in units of -dBm. The range is 0x0 to 0x50.

**Sleep Mode (Non Beacon):** Configure low power options for non-beaconing systems.

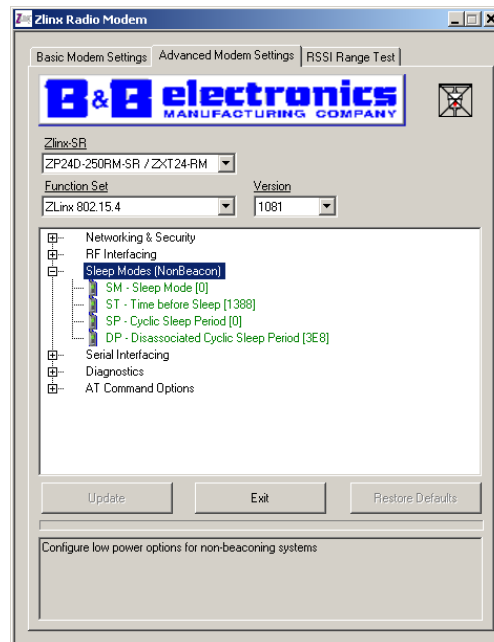

Figure 5-37 Sleep Mode (Non Beaconing) (ZXT24-RM)

**SM – Sleep Mode:** Set/read sleep mode: Pin Hibernate is lowest power, Pin Doze provides the fastest wake up, Cyclic Sleep Remote with or without pin wake up. This is a pull-down option. Selections are:

- 0 – No Sleep
- 1 – Pin Hibernate
- 2 – Pin Doze
- 3 – Reserved (NOT USED)
- 4 – Cycle Sleep Remote
- 5 – Cycle Sleep Remote with Pin

**ST – Time Before Sleep:** Set/read time period of inactivity (no serial or RF data is sent or received) before activating Sleep Mode. The ST parameter is used only with Cyclic Sleep settings (SM=4-5). Set ST on Cyclic Sleep Coordinator to match Cyclic Sleep Remotes. Range is 0x1 to 0xFFFF.

**SP – Cycle Sleep Period:** Set/read Cyclic sleep period for cyclic sleeping remotes. Set SP on Coordinator to match End Device. Coordinator will discard indirect messages after a period of 2.5\*SP, set Coordinator SP = 0 to send direct messages. Maximum sleep period is 268 seconds (0x68B0).

Range is 0x0 to 0x68B0.

**DP – Disassociated Sleep Period:** Set/read sleep period for cyclic sleeping remotes that are configured for Association but that are not associated to a Coordinator. Maximum sleep period is 268 seconds (0x68B0). Range is 0x1 to 0x68B0.

**Serial Interfacing:** Change modem interfacing options.

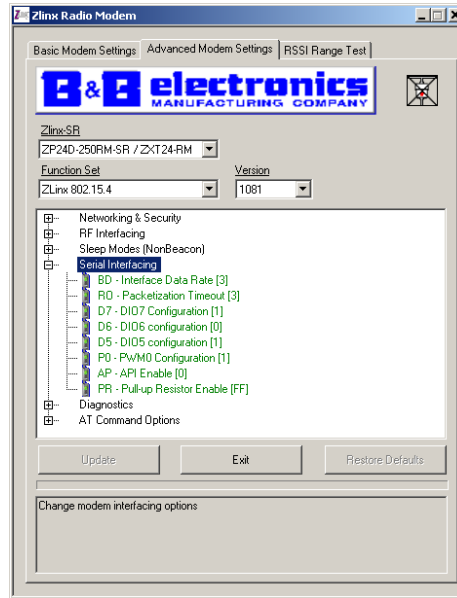

**Figure 5-38 Serial Interfacing (ZXT24-RM)**

**BD – Interface Data Rate:** Set/read the serial interface baud rate for communication between modem serial port and host. Request non-standard baud rates with values above 0x80 using a terminal window. Read BD register to find actual baud rate achieved. This is a pull-down option. Selections are:

- 0 – 1200
- 1 – 2400
- 2 – 4800
- 3 – 9600
- 4 – 19200
- 5 – 38400
- 6 – 57600
- 7 – 115200

**RD – Receive Packetization Timeout:** Set/read number of character times of inter-character delay required before transmission begins. Set to zero to transmit characters as they arrive instead of buffering them into one RF packet.

The range is 0x0 to 0xFF.

**D7 – DIO7 Configuration:** Configure options for the DIO7 line of the module. Options include: CTS flow control. This is a pull-down option. Selections are:

- 0 – Disable
- 1 – CTS Flow Control

**D6 – DIO6 Configuration:** Configure options for the DIO6 line of the module. Options include: RTS flow control. This is a pull-down option. Selections are:

- 0 – Disable
- 1 – RTS Flow Control

**D5 – DIO5 Configuration:** Configure options for the DIO5 line of the module. Options include: Associated LED indicator (blinks when associated). This is a pull-down option. Selections are:

- 0 – Disable
- 1 – Associated Indicator

**P0 – PWMO Configuration:** Select/Read function for PWM0. This is a pull-down option. Selections are:

- 0 – Disable
- 1 – RSSI

**AP – API Enable:** Enables API mode. This is a pull-down option. Selections are:

- 0 – API Disabled
- 1 – API Enabled
- 2 – API Enabled with PPI

**PR – Pull Up Resistor Enable:** Set/read bitfield to configure internal pullup resistors status for I/O lines. 1=internal pullup enabled, 0=no internal pullup. Bitfield map: Bit 7 - DIN (P3), Bit 6 - IO8/SLEEP\_RQ (P9), Bit 5 - DIO6/RTS (P16), Bit 4 - DIO0 (P20), Bit 3 - DIO1 (P19), Bit 2 - DIO2 (P18), Bit 1 - DIO3 (P17), Bit 0 - DIO4 (P11).

The range is 0x0 to 0xFF

**Diagnostics:** Access diagnostic parameters.

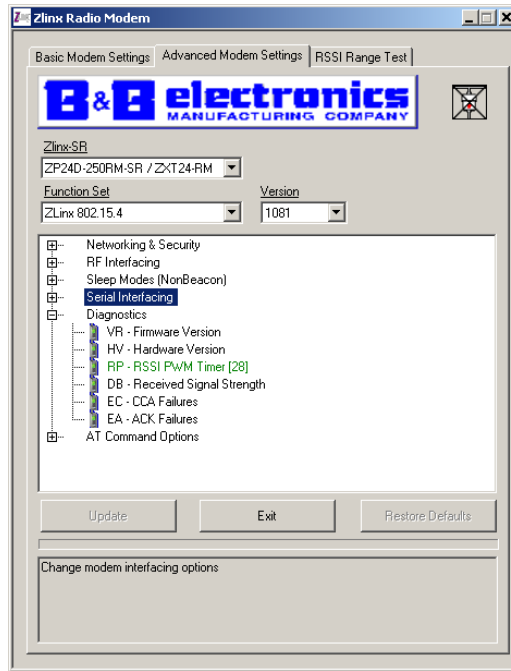

**Figure 5-39 Diagnostics (ZXT24-RM)**

**RP – RSSI PMW Timer:** Set/read PWM timer register. Set duration of PWM (pulse width modulation) signal output. The signal duty cycle is updated with each received packet and is shut off when the timer expires. The range is 0x0 to 0xFF.

**AT Command Options:** Change AT command mode behavior.

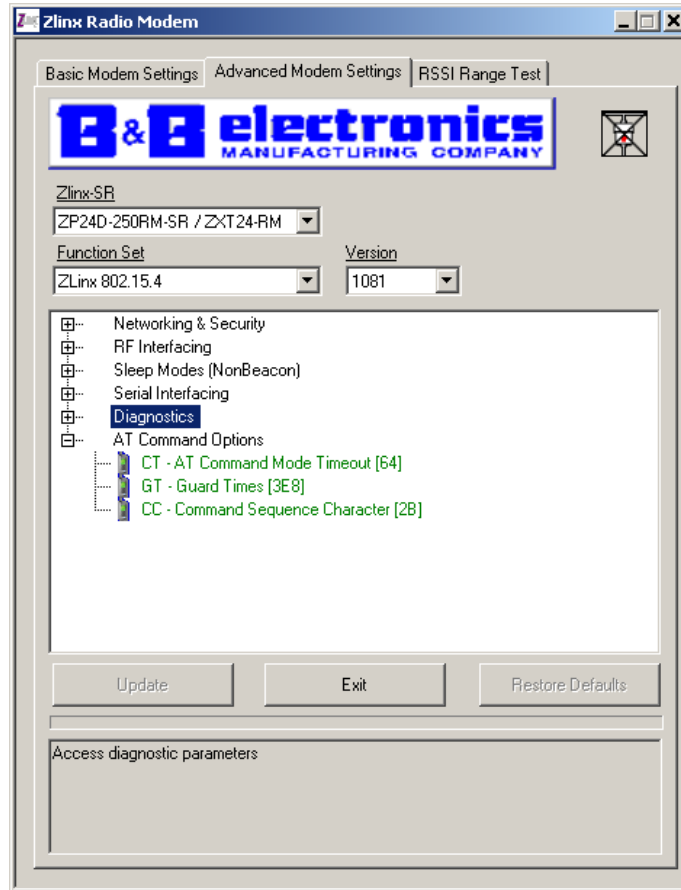

**Figure 5-40 AT Command Options (ZXT24-RM)**

**CT – AT Command Mode Timeout:** Set/read command mode timeout parameter. If no valid commands have been received within this time period, the modem returns to Idle Mode from AT Command Mode.

The range is 0x2 to 0xFFFF

**GT – Guard Times:** Set required period of silence before, after and between the Command Mode Characters of the Command Mode Sequence (GT + CC + GT). The period of silence is used to prevent inadvertent entrance into AT Command Mode.

The range is 0x2 to 0xFFFF.

**CC – Command Sequence Character:** Set/read character value to be used to break from data mode to command mode. The default value <2Bh> is the ASCII code for the plus ('+') character.

The range is 0x0 to 0xFF.

**5.3.3 RADIO MODEM CONFIGURATION SCREEN (OFF-LINE)**

The Off-Line Configuration is used to view the normal default settings for the radio modem when a modem is not connected.

This can be used when providing telephone assistance to a field technician, and to look at the settings available while reviewing the manual.

**5.3.4 RADIO MODEM FIRMWARE UPDATE SCREEN**

From time to time firmware updates will become available. These updates are installed through the firmware update screen.



**Figure 5-41 Manager Screen**

Clicking the Radio Modem Firmware Updater link will take you to the firmware update screen. Section six contains instructions to update the firmware.

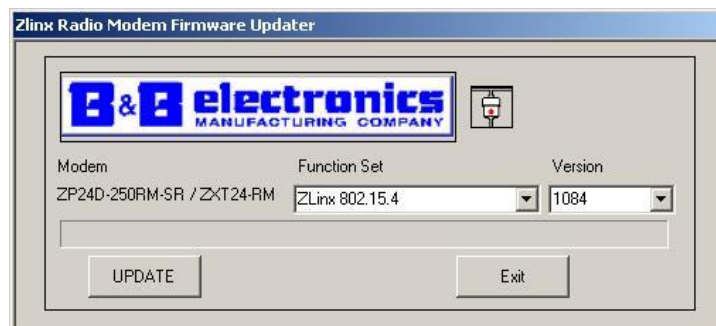

**Figure 5-42 Firmware Update Screen**

**5.3.5 RETURN TO MANAGER**

The Return to Manager Link is used to take you out of the radio modem screen back to the main Zlinx<sup>®</sup> screen

**5.3.6 EXIT**

Exit is used to exit the program.

## 6 - STARTUP AND CONFIGURATION

### 6.1 BASIC SETTINGS



**Figure 6-1 Radio Modem Basic Settings**

#### 6.1.1 CHANNEL NUMBER

This identifies the channel within the 900 MHz or 2.4 GHz band that you are using. The channel you select must be the same on every Zlinx<sup>®</sup> product you desire to communicate with. If interference is experienced from other devices outside your control, you can change to another channel to improve communications.

#### 6.1.2 NETWORK IDENTIFIER

The network identifier is used to separate Zlinx<sup>®</sup> products into networks. The network identifier must be the same on each product you desire to communicate with.

#### 6.1.3 BAUD RATE, STOP BITS, PARITY, AND FLOW CONTROL

Refer to section 5.3.2.1 and 5.3.2.2.

### 6.2 ADVANCED SETTINGS

Advanced modem tab is described in section five.

### 6.3 RF MODEM OPERATION

#### 6.3.1 TRANSPORT OPERATION

By default, modem operates in Transparent Mode. When operating in this mode, the modems act as a serial line replacement - all received UART data is queued up for RF transmission. When RF data is received, the data is sent out of the modem.

---

### 6.3.2 SERIAL TO RF PACKETIZATION

Data is buffered in the input buffer until one of the following causes the data to be packetized and transmitted:

- No serial characters are received for the amount of time determined by the RO (Packetization Timeout) parameter. If RO = 0 packetization begins when a character is received.
- The maximum number of characters that will fit in an RF packet (2048 for ZXT9-RM) (202 for ZXT24-RM) is received.
- The Command Mode Sequence (GT + CC + GT) is received. Any character buffered in the input buffer before the sequence is transmitted.

If the modem cannot immediately transmit (for instance, if it is already receiving RF data), the serial data is stored in the input buffer. The data is packetized and sent at any RO timeout or when the maximum packet size is received.

If the input buffer becomes full, hardware or software flow control must be implemented in order to prevent overflow (loss of data between the host and modem).

---

### 6.3.3 API OPERATION

API (Application Programming Interface) Operation is an alternative to the default Transparent Operation. The frame-based API extends the level to which a host application can interact with the networking capabilities of the modem.

When in API mode, all data entering and leaving the modem is contained in frames that define operations or events within the modem.

Transmit Data Frames (received by modem) include:

- RF transmit data frame
- Command frame (equivalent to AT commands)

Receive Data Frames (sent out by modem) include:

- RF received data frame
- Command response
- Event notifications such as reset, associate, disassociate, etc.

The API provides alternative means of configuring modems and routing data at the host application layer. A host application can send data frames to the modem that contain address and payload information instead of using command mode to modify addresses. The modem will send data frames to the application containing status packets; as well as source, RSSI and payload information from received data packets.

The API operation option facilitates many operations such as the examples cited below:

- Transmitting data to multiple destinations without entering Command Mode
- Receive success/failure status of each transmitted RF packet
- Identify the source address of each received packet

**Note:** to implement API operations, refer to API sections.

### 6.3.4 FLOW CONTROL

#### Input Buffer

When serial data received by modem, the data is stored in the Input Buffer until it can be processed.

**Hardware Flow Control (CTS)** When the input buffer is 17 bytes away from being full, by default, the modem de-asserts CTS (high) to signal to the host device to stop sending data [refer to FT (Flow Control Threshold) and CS (GPO1 Configuration) Commands]. CTS is re-asserted after the buffer has 34 bytes of memory available.

**Software Flow Control (XON)** XON/XOFF software flow control can be enabled using the FL (Software Flow Control) Command. This option only works with ASCII data.

How to eliminate the need for flow control:

- Send messages that are smaller than the input buffer size. The size of the input buffer varies according to the packet size (PK parameter) and the parity setting (NB parameter) used.
- Interface at a lower baud rate [BD (Interface Data Rate) parameter] than the RF data rate (BR parameter).

Two cases in which the inputBuffer may become full and possibly overflow:

- If the serial interface data rate is set higher than the RF data rate of the modem, the modem will receive data from the host faster than it can transmit the data over-the-air.
- If the modem is receiving a continuous stream of RF data or if the modem is monitoring data on a network, any serial data that arrives on the modem is placed in the Input Buffer. The data in the input buffer will be transmitted over-the-air when the modem no longer detects RF data in the network.

#### Output Buffer

When RF data is received, the data enters the output buffer and is sent out the serial port to a host device. Once the output buffer reaches capacity, any additional incoming RF data is lost. The output buffer stores at least 2.1 KB.

**Hardware Flow Control (RTS)** If RTS is enabled for flow control (RT Parameter = 2), data will not be sent out the output buffer as long as RTS (pin 10) is de-asserted.

**Software Flow Control (XOFF)** XON/XOFF software flow control can be enabled using the FL (Software Flow Control) Command. This option only works with ASCII data.

Two cases in which the output buffer may become full and possibly overflow:

- If the RF data rate is set higher than the interface data rate of the modem, the modem will receive data from the transmitting modem faster than it can send the data to the host.
- If the host does not allow the modem to transmit data out from the output buffer because of being held off by hardware or software flow control.

### 6.3.5 SLEEP MODE

Sleep Modes enable the module to enter states of low-power consumption when not in use. Three software Sleep Modes are supported:

- Pin Sleep (Host Controlled)
- Serial Port Sleep (Wake on Serial Port activity)
- Cyclic Sleep (Wake on RF activity)

In order to enter Sleep Mode, one of the following conditions must be met (in addition to the modem having a non-zero SM parameter value):

- The modem is idle (no data transmission or reception) for the amount of time defined by the ST (Time before Sleep) parameter. **[Note: ST is only active when SM = 4-5.]**
- SLEEP (DTR) is asserted (only for the 'Pin Sleep' option).

When in Sleep Mode, the modem will not transmit or receive data until the modem first transitions to Idle Mode. All Sleep Modes are enabled and disabled using SM Command. Transitions into and out of Sleep Modes are triggered by various mechanisms as shown in the table below.

The SM (Sleep Mode) command is central to setting all Sleep Mode configurations. By default, Sleep Modes are disabled (SM = 0) and the modem remains in Idle/Receive Mode. When in this state, the modem is constantly ready to respond to serial or RF activity.

Refer to 'Hardware Sleep' section of the 'Shutdown Mode' section to enable the modem's lowest power-consuming state.

#### 6.3.5.1 PIN SLEEP MODE

##### Pin Sleep (SM = 1)

- Pin/Host-controlled

This mode is voltage level activated. When DTR/SLP is asserted, the modem will finish any transmitting or receiving activity, enter idle mode, then enter a state of sleep. When in Pin Sleep Mode, the modem will not respond to serial or RF activity.

After enabling Pin Sleep, the SLEEP pin controls whether the modem is active or sleeping. When SLEEP is de-asserted, the modem is fully operational. When SLEEP is asserted, the modem transitions to Sleep Mode and remains in its lowest power-consuming state until the pin is de-asserted.

**Note:** The modem will complete a transmission or reception before activating Pin Sleep.

#### 6.3.5.2 SERIAL PORT SLEEP MODE

##### Serial Port Sleep (SM = 2)

- Wake on serial port activity

Serial Port Sleep is a Sleep Mode in which the modem runs in a low power state until serial data is detected on the modem.

The period of time the modem sleeps is determined by ST (Time before Sleep) Command. Once a character is received through the input, the modem returns to Idle Mode and is fully operational.

### 6.3.5.3 CYCLE SLEEP MODE

**Cyclic Sleep (SM = 4-8)** Cyclic Sleep Modes allow modems to periodically wake and check for RF data. The modem wakes according to the times designated by the Cyclic sleep settings. If the modem detects a wake-up initializer during the time it is awake, the modem synchronizes with the transmitting modem and receives data after the wake-up initializer runs its duration. Otherwise, the modem returns to Sleep Mode and continues to cycle in and out of activity until a wake-up initializer is detected.

While the modem is in Cyclic Sleep Mode, CTS is de-asserted (high) to indicate that data should not be sent to the modem. When the modem awakens to listen for data, CTS is asserted and any data received on the modem input is transmitted.

The modem remains in Sleep Mode for a user-defined period of time ranging from 0.5 seconds to 16 seconds (SM parameters 4 through 8). After this interval of time, the modem returns to Idle Mode and listens for a valid data packet for 100 ms. If the modem does not detect valid data (on any frequency), the modem returns to Sleep Mode. If valid data is detected, the modem transitions into Receive Mode and receives the incoming RF packets. The modem then returns to Sleep Mode after a period of inactivity determined by the ST "Time before Sleep" parameter.

The modem can also be configured to wake from Cyclic Sleep when DTR/SLP is de-asserted. To configure a modem to operate in this manner, PW (Pin Wake-up) Command must be issued. Once the SLEEP pin is de-asserted, the modem is forced into Idle Mode and can begin transmitting or receiving data. It remains active until data is no longer detected for the period of time specified by the ST Command, at which point it resumes its low-power cyclic state.

**Cyclic Scanning** Each RF transmission consists of an RF Initializer and Payload. The RF initializer contains initialization information and all receiving modems must wake during the wake-up initializer portion of data transmission in order to be synchronized with the transmitting modem and receive the data.

---

### 6.3.6 COMMAND MODE

To modify or read RF modem parameters, the modem must first enter into Command Mode (state in which incoming characters are interpreted as commands). Two command types are supported: AT Commands and Binary Commands.

For modified parameter values to persist in the modem registry, changes must be saved to non-volatile memory using the WR (Write) command. Otherwise, parameters are restored to previously saved values when the modem is powered off and then on again.

---

#### 6.3.6.1 MODEM CONFIGURATION SWITCH

The Configuration Switch provides an alternate method for entering into Command Mode.

To enter Command Mode at the default RF data rate of the modem, remove power, hold the Configuration Switch (PB1) down and power up the modem, then release the Configuration Switch.

The Serial port default is 115200, 8, N, 1.

### 6.3.7 AT COMMAND MODE

#### 6.3.7.1 ENTERING AT COMMAND MODE

Send the 3-character command sequence "+++" and observe guard times before and after the command characters.

Default AT Command Mode Sequence (for transition to Command Mode):

- No characters sent for one second [refer to the BT (Guard Time Before) Command]
- Input three plus characters ("+++") within one second [refer to the CC (Command Sequence Character) Command].
- No characters sent for one second [refer to the AT (Guard Time After) Command]

All of the parameter values in the sequence can be modified to reflect user preferences.

#### 6.3.7.2 SENDING AT COMMANDS

Send AT commands and parameters using the syntax shown below.

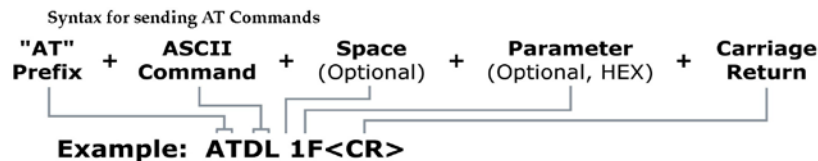

To read a parameter value stored in the RF modem's register, omit the parameter field.

The preceding example would change the RF modem Destination Address (low) to "0x1F." To store the new value to non-volatile (long term) memory, subsequently send the ATWR (Write) command before powering off the modem.

**System Response.** When a command is sent to the modem, the modem will parse and execute the command. Upon successful execution of a command, the modem returns an OK message. If the execution of a command results in an error, the modem returns an "Error" message.

#### 6.3.7.3 EXIT AT COMMAND MODE

If no valid AT Commands are received within the time specified by the CT (Command Mode Timeout) Command, the RF modem automatically returns to Idle Mode.

To exit the AT command mode, send the ATCN (Exit Command Mode) command (followed by a carriage return).

### 6.3.8 BINARY COMMAND MODE

Sending and receiving parameter values using binary commands is the fastest way to change operating parameters of the modem. Binary commands are used most often to sample signal strength [refer to DB (Received Signal Strength) parameter] and/or error counts; or to change modem addresses and channels for polling systems when a quick response is necessary. Since the sending and receiving of parameter values takes place through the same serial data path as 'live' data (received RF payload), interference between the two types of data can be a concern.

Common questions about using binary commands:

What are the implications of asserting CMD while live data is being sent or received?

After sending serial data, is there a minimum time delay before CMD can be asserted?

Is a time delay required after CMD is de-asserted before payload data can be sent?

How does one discern between live data and data received in response to a command?

The CMD pin (pin 10) must be asserted in order to send binary commands to the modem. The CMD pin can be asserted to recognize binary commands anytime during the transmission or reception of data. The status of the CMD signal is only checked at the end of the stop bit as the byte is shifted into the serial port. The application does not allow control over when data is received, except by waiting for dead time between bursts of communication.

If the command is sent in the middle of a stream of payload data to be transmitted, the command will essentially be executed in the order it is received. If the modem is continuously receiving data, the radio will wait for a break in the received data before executing the command. The CTS signal will frame the response coming from the binary command.

A minimum time delay of 100  $\mu$ s (after the stop bit of the command byte has been sent) must be observed before the CMD pin can be de-asserted. The command executes after all parameters associated with the command have been sent. If all parameters are not received within 0.5 seconds, the modem returns to Idle Mode.

**Note:** *When parameters are sent, they are two bytes long with the least significant byte sent first. Binary commands that return one parameter byte must be written with two parameter bytes.*

*Commands can be queried for their current value by sending the command logically ORed (bit-wise) with the value 0x80 (hexadecimal) with CMD asserted. When the binary value is sent (with no parameters), the current value of the command parameter is sent back through the DO pin.*

**IMPORTANT:** In order for the modem to recognize a binary command, the RT (GPI1 Configuration) parameter must be set to one. If binary programming is not enabled (RT parameter value is not equal to '1'), the modem will not recognize that the CMD pin is asserted and therefore will not recognize the data as binary commands.

## 6.4 ZXT9-RM CONFIGURATION

### 6.4.1 ADVANCED PROGRAMMING

#### 6.4.1.1 PROGRAMMING EXAMPLES USING AT COMMANDS

The programming examples in this section require the installation of a hyper terminal program and a connection to a PC.

'CR' stands for carriage return:

Send AT Command	System Response_
+++	OK <CR> (Enter into Command Mode)
ATDT <Enter>	{current value} <CR> (Read Destination Address)
ATDT1A0D <Enter>	OK <CR> (Modify Destination Address)
ATWR <Enter>	OK <CR> (Write to non-volatile memory)
ATCN <Enter>	OK <CR> (Exit Command Mode)

Send AT Command_	System Response_
+++	OK <CR> (Enter into Command Mode)
ATDT <Enter>	{current value} <CR> (Read Destination Address)
ATDT1A0D,WR,CN <Enter>	OK <CR> (Execute commands)

#### 6.4.1.2 PROGRAMMING USING BINARY COMMANDS

Example: Use binary commands to change the RF modem's destination address to 0x1A0D and save the new address to non-volatile memory.

1. RT Command must be set to '1' in AT Command Mode to enable binary programming
2. Assert CMD (Pin 10 is driven high). (Enter Binary Command Mode)
3. Send Bytes [parameter bytes must be 2 bytes long]:
  - 00 (Send DT (Destination Address) Command)
  - 0D (Least significant byte of parameter bytes)
  - 1A (Most significant byte of parameter bytes)
  - 08 (Send WR (Write) Command)
4. De-assert CMD (pin 10 is driven low). (Exit Binary Command Mode)

**Note:** CTS is high when a command is being executed. Hardware flow control must be disabled as CTS will hold off parameter bytes.

**6.4.2 COMMAND REFERENCE TABLE**

Modems expect numerical values in hexadecimal. Hexadecimal values are designated by a "0x" prefix. Decimal equivalents are designated by a "d" suffix.

AT Command	Binary Command	AT Command Name	Parameter Range	Command Category	# Bytes Returned	Default
%V	0x3B (59d)	Board Voltage	0x2CCCA - 0x5BFFA [read-only]	Diagnostics	4	-
AM	0x40 (64d)	Auto-set MY	-	Networking & Security	-	-
AP v2.x20*	-	API Enable	0 - 2	Serial Interfacing	1	0
AT	0x05 (5d)	Guard Time After	2 - (ATST-3) [x 100 msec]	Command Mode Options	2	0x0A (10d)
BD	0x15 (21d)	Interface Data Rate	0 - 8 (standard rates) 0x39 - 0x1C9C38 (non-standard rates)	Serial Interfacing	4	3
BR	0x39 (57d)	RF Data Rate	0 - 1	RF Interfacing	1	1
BT	0x04 (4d)	Guard Time Before	0 - 0xFFFF [x 100 msec]	Command Mode Options	2	0x0A (10d)
CC	0x13 (19d)	Command Sequence Character	0x20 - 0x7F	Command Mode Options	1	0x2B ["+"] (43d)
CD	0x28 (40d)	GPO2 Configuration	0 - 4	Serial Interfacing	1	2
CF	-	Number Base	0 - 2	Command Mode Options	1	1
CN	0x09 (9d)	Exit Command Mode	-	Command Mode Options	-	-
CS	0x1F (31d)	GPO1 Configuration	0 - 4	Serial Interfacing	1	0
CT	0x06 (6d)	Command Mode Timeout	2 - 0xFFFF [x 100 ms]	Command Mode Options	2	0xC8 (200d)
DB	0x36 (54d)	Received Signal Strength	0x6E - 0x28 [read-only]	Diagnostics	2	-
DT	0x00 (0d)	Destination Address	0 - 0xFFFF	Networking & Security	2	0
E0	0x0A (10d)	Echo Off	-	Command Mode Options	-	-
E1	0x0B (11d)	Echo On	-	Command Mode Options	-	-
ER	0x0F (15d)	Receive Error Count	0 - 0xFFFF	Diagnostics	2	0
FH	0x0D (13d)	Force Wake-up Initializer	-	Sleep (Low Power)	-	-
FL	0x07 (7d)	Software Flow Control	0 - 1	Serial Interfacing	1	0

FS	0x3E (62d)	Forced Sync Time	0 - 0xFFFF [x 10 msec]	RF Interfacing	2	0
FT	0x24 (36d)	Flow Control Threshold	0 - (DI buffer size - 0x11) [Bytes]	Serial Interfacing	2	DI buffer size minus 0x11
GD	0x10 (16d)	Receive Good Count	0 - 0xFFFF	Diagnostics	2	0
HP	0x11 (17d)	Hopping Channel	0 - 9	Networking & Security	1	0
HT	0x03 (3d)	Time before Wake-up Initializer	0 - 0xFFFF [x 100 msec]	Sleep (Low Power)	2	0xFFFF (65535d)
HV	-	Hardware Version	0 - 0xFFFF [read-only]	Diagnostics	2	-
ID	0x27 (39d)	Modem VID	0x11 - 0x7FFF (user-settable) 0x8000 - 0xFFFF (factory-set, read-only)	Networking & Security	2	0x3332 (13106d)
KY	0x3C (60d)	AES Encryption Key	0 - (64 hex digits all set to 'F')	Networking & Security	2	0 (disabled)
LH	0x0C (12d)	Wake-up Initializer Timer	0 - 0xFF [x 100 msec]	Sleep (Low Power)	1	1
MD v2.x20*	0x31 (49d)	RF Mode	0 - 6	Networking & Security	1	0
MK	0x12 (18d)	Address Mask	0 - 0xFFFF	Networking & Security	2	0xFFFF (65535d)
MT	0x3D (61d)	Multi-Transmit	0 - 0xFF	Networking & Security	1	0
MY	0x2A (42d)	Source Address	0 - 0xFFFF	Networking & Security	2	0xFFFF (65535d)
NB	0x23 (35d)	Parity	0 - 4	Serial Interfacing	1	0
PB v2.x20*	0x45 (69d)	Polling Begin Address	0 - 0xFFFF	Networking & Security	2	0
PD v2.x20*	0x47 (71d)	Minimum Polling Delay	0 - 0xFFFF (Base: (x 1 ms), Remote: [x 10 ms])	Networking & Security	2	0
PE v2.x20*	0x46 (70d)	Polling End Address	0 - 0xFFFF	Networking & Security	2	0
PK	0x29 (41d)	Maximum RF Packet Size	1 - 0x800 [Bytes]	RF Interfacing	2	varies
PL	0x3A (58d)	TX Power Level	0 - 4	RF Interfacing	1	4 (1 Watt)
PW	0x1D (29d)	Pin Wake-up	0 - 1	Sleep (Low Power)	1	0
RB	0x20 (32d)	Packetization Threshold	1 - Current value of PK	Serial Interfacing	2	0x800 (2048d)
RC	-	Ambient Power - Single Channel	0 - 0x31 [dBm, read-only]	Diagnostics	1	-
RE	0x0E (14d)	Restore Defaults	-	(Special)	-	-

RM	-	Ambient Power - All Channels	No parameter - 0x7D0	Diagnostics	2	-
RN	0x19 (25d)	Delay Slots	0 - 0xFF [slots]	Networking & Security	1	0
RO	0x21 (33d)	Packetization Timeout	0 - 0xFFFF [x UART character time]	Serial Interfacing	2	3
RP	0x22 (34d)	RSSI PWM Timer	0 - 0xFF [x 100 msec]	Diagnostics	1	0x20 (32d)
RR	0x18 (24d)	Retries	0 - 0xFF	Networking & Security	1	0x0A (10d)
RT	0x16 (22d)	GPI1 Configuration	0 - 2	Serial Interfacing	1	0
SB	0x37 (55d)	Stop Bits	0 - 1	Serial Interfacing	1	0
SH	0x25 (37d)	Serial Number High	0 - 0xFFFF [read-only]	Diagnostics	2	varies
SL	0x26 (38d)	Serial Number Low	0 - 0xFFFF [read-only]	Diagnostics	2	varies
SM	0x01 (1d)	Sleep Mode	0 - 8 (3 is reserved)	Sleep (Low Power)	1	0
ST	0x02 (2d)	Time before Sleep	(ATAT+3) - 0x7FFF [x 100 msec]	Sleep (Low Power)	2	0x64 (100d)
TP	0x38 (56d)	Board Temperature	0 - 0x7F [read-only]	Diagnostics	1	-
TR	0x1B (27d)	Delivery Failure Count	0 - 0xFFFF [read-only]	Diagnostics	2	0
TT	0x1A (26d)	Streaming Limit	0 - 0xFFFF [0 = disabled]	Networking & Security	2	0
TX	0x3F (63d)	Transmit Only	0 - 1	RF Interfacing	1	0
VL	-	Firmware Version - verbose	Returns string	Diagnostics	-	-
VR	0x14 (20d)	Firmware Version	0 - 0xFFFF [read-only]	Diagnostics	2	-

\*Firmware version in which the command was first introduced (firmware versions are numbered in hexadecimal notation.)

**6.4.2.1 COMMAND DESCRIPTIONS**

Command descriptions in this section are listed alphabetically. Command categories are designated within "< >" symbols that follow each command title. Zlinx Xtreme Radio Modems expect parameter values in hexadecimal (designated by the "0x" prefix).

**Command Descriptions**

Command descriptions in this section are listed alphabetically. Command categories are designated within "< >" symbols that follow each command title. Zlinx Xtreme Radio Modems expect parameter values in hexadecimal (designated by the "0x" prefix).

**%V (Board Voltage) Command**

<Diagnostics> %V Command is used to read the current voltage of the modem circuit board.

Sample Output:

5.02 V (when ATCF = 0)  
 5051F (when ATCF = 1) \*  
 5.02 (when ATCF = 2)

\* When CF = 1 (default), a hex integer is shown that is equal to (voltage \* 65536d).

AT Command: AT%V
Binary Command: 0x3B (59 decimal)
Parameter Range (read-only): 0x2CCCA - 0x5BFFA (2.80 - 5.75 decimal)
Number of bytes returned: 4

**AM (Auto-set MY) Command**

<Networking & Security> AM Command is used to automatically set the MY (Source Address) parameter from the factory-set serial number of the modem. The address is formed with bits 29, 28 and 13-0 of the serial number (in that order).

The resulting value is displayed as a result of this command.

AT Command: ATAM
Binary Command: 0x40 (64 decimal)

**AP (API Enable) Command**

<Serial Interfacing> The AP command is used to enable the RF modem to operate using a frame-based API instead of using the default Transparent (UART) mode.

AT Command: ATAP	
Parameter Range: 0 - 2	
Parameter	Configuration
0	API Disabled (Transparent operation)
1	API enabled (w/out escaped characters)
2	API enabled (with escaped characters)
Default Parameter Value: 0	
Number of Bytes Returned: 1	
Minimum Firmware Version Required: v2.x20	

**AT (Guard Time After) Command**

<Command Mode Options> AT Command is used to set/read the time-of-silence that follows the command sequence character (CC Command) of the AT Command Mode Sequence (BT + CC + AT). By default, 1 second must elapse before and after the command sequence character.

The times-of-silence surrounding the command sequence character are used to prevent inadvertent entrance into AT Command Mode.

Refer to the 'AT Command Mode' section for more information regarding the AT Command Mode Sequence.

AT Command: ATAT
Binary Command: 0x05 (5 decimal)
Parameter Range: 2 - (ATST-3), up to 0x7FFC[x 100 milliseconds]
Default Parameter Value: 0x0A (10 decimal)
Number of bytes returned: 2
Related Commands: BT (Guard Time Before), CC (Command Sequence Character)

**BD (Interface Data Rate) Command**

<Serial Interfacing> The BD command is used to set and read the serial interface data rate (baud rate) used between the RF modem and host. This parameter determines the rate at which serial data is sent to the modem from the host. Modified interface data rates do not take effect until the CN (Exit AT Command Mode) command is issued and the system returns the 'OK' response.

When parameters 0-8 are sent to the module, the respective interface data rates are used (as shown in the table on the right).

The RF data rate is not affected by the BD parameter. If the interface data rate is set higher than the RF data rate, a flow control configuration may need to be implemented.

The range between standard and non-standard baud rates (0x09 - 0x38) is invalid.

**Non-standard Interface Data Rates:**

Any value above 0x38 will be interpreted as an actual baud rate. When a value above 0x38 is sent, the closest interface data rate represented by the number is stored in the BD register. For example, a rate of 19200 bps can be set by sending the following command line "ATBD4B00".

When the BD command is sent with a nonstandard interface data rate, the UART will adjust to accommodate the requested interface rate. In most cases, the clock resolution will cause the stored BD parameter to vary from the parameter that was sent (refer to the table below). Reading the BD command (send "ATBD" command without an associated parameter value) will return the value actually stored in the module's BD register

AT Command: ATBD  
Binary Command: 0x15 (21 decimal)  
Parameter Range: 0 - 8 (standard rates)  
0x39-0x1C9C38 (non-standard rates)

Parameter	Configuration (bps)
0	1200
1	2400
2	4800
3	9600
4	19200
5	38400
6	57600
7	115200

Default Parameter Value: 3  
Non-standard baud rates supported as of firmware v2.x20  
Number of bytes returned: 4

BD Parameter Sent (HEX)	Interface Data Rate (bps)	BD Parameter Stored (HEX)
0	1200	0
4	19,200	4
7	115,200	7
12C	300	12B
1C200	115,200	1B207

\* The 115,200 baud rate setting is actually at 111,111 baud (-3.5% target UART speed).

**BR (RF Data Rate) Command**

<RF Interfacing> The BR command is used to set and read the RF data rate (rate that RF data is transmitted over-the-air) of the modem.

AT Command: ATBR  
Binary Command: 0x39 (57 decimal)  
Parameter Range: 0 - 1

Parameter	Baud (bps) Configuration
0	9600
1	115200

Default Parameter Value: 1  
Number of bytes returned: 1

**BT (Guard Time Before) Command**

<AT Command Mode Options> The CC command is used to set/read the ASCII character used between guard times of the AT Command Mode Sequence (BT + CC + AT). This sequence enters the module into AT Command Mode so that data

AT Command: ATCC  
Binary Command: 0x13 (19 decimal)  
Parameter Range: 0x20 - 0x7F  
Default Parameter Value: 0x2B (ASCII "+")  
Number of bytes returned: 1  
Related Commands: AT (Guard Time After), BT (Guard Time Before)

entering the module (from the host) is recognized as commands instead of payload.

Refer to the 'AT Command Mode' section for more information regarding the AT Command Mode Sequence.

**CC (Command Sequence Character) Command**

<AT Command Mode Options> The CC command is used to set/read the ASCII character used between guard times of the AT Command Mode Sequence (BT + C C + AT). This sequence enters the modem into AT Command Mode so that data entering the modem (from the host) is recognized as commands instead of payload.

Refer to the 'AT Command Mode' section for more information regarding the AT Command Mode Sequence

AT Command: ATCC
Binary Command: 0x13 (19 decimal)
Parameter Range: 0x20 - 0x7F
Default Parameter Value: 0x2B (ASCII "+")
Number of bytes returned: 1
Related Commands: AT (Guard Time After), BT (Guard Time Before)

**CD (GPO2 Configuration) Command**

<Serial Interfacing> CD Command is used to select/read the behavior of the GPO 2 line (pin 3).

AT Command: ATCD	
Binary Command: 0x28 (40 decimal)	
Parameter Range: 0 – 8 (standard rates)	
Parameter	Configuration
0	RX LED
1	Default High
2	Default Low
3	(reserved)
4	RX LED (valid address only)
Default Parameter Value: 2	
Number of bytes returned: 1	

**CF (Number Base) Command**

<Command Mode Options> CF command is used to set/read the command formatting setting. The following commands are always entered and read in hex, no matter the CF setting:

- VR (Firmware Version)
- HV (Hardware Version)
- KY (AES Encryption Key)

AT Command: ATCF	
Parameter Range: 0 – 2	
Parameter	Configuration
0	Commands utilize default number base; decimal commands may output units
1	All commands forced to unsigned, unit-less hex
2	Commands utilize their default number base; no units are output
Default Parameter Value: 1	
Number of bytes returned: 1	

**CN (Exit AT Command Mode) Command**

<Command Mode Options> The CN command is used to explicitly exit the RF modem from AT Command Mode.

AT Command: ATCN
Binary Command: 0x09 (9 decimal)

**CS (GP01 Configuration) Command**

<Serial Interfacing> CS Command is used to select the behavior of the GP01 pin (pin 9). This output can provide RS-232 flow control, control the TX enable signal (for RS-485 or RS-422 operations).

By default, GP01 provides RS-232 CTS (Clear-to-Send) flow control.

AT Command: ATCS	
Binary Command: 0x1F (31 decimal)	
Parameter Range: 0 – 4	
Parameter	Configuration
0	RS-232 CTS flow control
1	RS-485 TX enable l
2	High
3	RS-485 TX enable high
4	Low
Default Parameter Value: 0	
Number of bytes returned: 1	
Related Commands: RT (GPI1 Configuration), TO (GP01 Timeout)	

**CT (Command Mode Timeout) Command**

<Command Mode Options> The CT command is used to set and read the amount of inactive time that elapses before the RF modem automatically exits from AT Command Mode and returns to Idle Mode.

Use the CN (Exit AT Command Mode) command to exit AT Command Mode manually.

AT Command: ATCT	
Binary Command: 0x06 (6 decimal)	
Parameter Range: 2 - 0xFFFF [x 100 milliseconds]	
Default Parameter Value: 0xC8 (200d)	
Number of bytes returned: 2	
Related Command: CN (Exit AT Command Mode)	

**DB (Received Signal Strength) Command**

<Diagnostics> DB Command is used to read the receive signal strength (in decibels relative to milliWatts) of the last received packet. This parameter is useful in determining range characteristics of the RF modules under various conditions.

In default mode, this command shows the power level in signed decimal format with the units (dBm). If CF = 1, the magnitude of the value is presented in unsigned hex. If CF = 2, the value is presented in decimal, but without the units.

Sample Output:

- 88 dBm (when ATCF = 0)
- 58 (when ATCF = 1)
- 88 (when ATCF = 2)

**NOTE:** If the DB register is read before the modem has received an RF packet, the modem will return a value of 0x8000 (which means an RF packet has not yet been received)

AT Command: ATDB	
Binary Command: 0x36 (54 decimal)	
Parameter Range (read-only): 0x6E - 0x28 (-110 to -40 Decimal)	
Number of bytes returned: 2	

**DT (Destination Address) Command**

<Networking & Security> DT Command is used to set/read the networking address of an RF modem. The modems utilize three filtration layers: Vendor ID Number (ATID), Channel (ATHP), and Destination Address (ATDT). The DT command assigns an address to a radio that enables it to communicate with other radios in the network. The simplest use of this command is that when MY=0xFFFF and

AT Command: ATDT	
Binary Command: 0x00	
Parameter Range: 0 - 0xFFFF	
Default Parameter Value: 0	
Number of bytes returned: 2	
Related Commands: HP (Hopping Channel), ID (Modem VID), MK (Address Mask), MY (Source Address)	

MK=0xFFFF on all radios in a network, only radios with matching DT's will communicate with each other.

If MY is not 0xFFFF, then DT acts as a transmit address and MY acts as a receive address. For example, MY can be set to unique values 1, 2, 3, etc. on unique radios in the network. Then set DT on the transmitting radio to match the MY of the receiving radio you intend to communicate with.

Setting DT=0xFFFF will broadcast to all radios in the network. Refer to the 'Addressing' section for more information

**E0 (Echo Off) Command**

<Command Mode Options> E0 Command turns off character echo in AT Comm and Mode.  
By default, echo is off.

AT Command: ATE0  
Binary Command: 0x0A (10 decimal)

**E1 (Echo On) Command**

<Command Mode Options> E1 Command enables character echo in AT Comm and Mode. Each typed character will be echoed back to the terminal when ATE1 is active. E0 (Echo Off) is the default

AT Command: ATE1  
Binary Command: 0x0B (11 decimal)

**ER (Receive Error Count) Command**

<Diagnostics> The ER command is used to set/read the number of receive-errors. The error count records the number of packets partially received then aborted on a reception error. This value returns to 0 after a reset and is not non-volatile (Value does not persist in the modem's memory after a power-up sequence). Once the Receive Error Count reaches its maximum value (up to 0xFFFF), it remains at its maximum count value until the maximum count value is explicitly changed or the modem is reset.

The ER parameter is not reset by pin, serial port or cyclic sleep modes

AT Command: ATER  
Binary Command: 0x0F (15 decimal)  
Parameter Range: 0 - 0xFFFF  
Default Parameter Value: 0  
Number of bytes returned: 2  
Related Commands: GD (Receive Good Count)

**FH (Force Wake-up Initializer) Command**

<Sleep (Low Power)> The FH command is used to force a Wake-up Initializer to be sent on the next transmission. Use only with cyclic sleep modes active on remote modems.

ATFH will not send a long header if ATHT = 0xFFFF. WR (Write) Command does not need to be issued with FH Command.

AT Command: ATFH  
Binary Command: 0x0D (13 decimal)

**FL (Software Flow Control) Command**

<Serial Interfacing> The FL command is used to configure software flow control. Hardware flow control is implemented with the modem as the GP01 pin (CTS pin of the RF modem), which regulates when serial data can be transferred to the module.

FL Command can be used to allow software flow control to also be enabled. The XON character used is 0x11 (17 decimal). The XOFF character used is 0x13 (19 decimal)

AT Command: ATFL  
Binary Command: 0x07 (7 decimal)  
Parameter Range: 0 - 1  
Parameter Configuration  
0 Disable software flow control  
1 Enable software flow control  
Default Parameter Value: 0  
Number of bytes returned: 1

**FS (Forced Synch Time) Command**

<RF Interfacing> The FS command only applies to streaming data. Normally, only the first packet of a continuous stream contains the full RF initializer. The RF modems then remain synchronized for subsequent packets of the stream. This parameter can be used to periodically force an RF initializer during such streaming. Any break in UART character reception long enough to drain the Input Buffer (UART receive buffer) and cause a pause in RF data transmission will also cause an RF initializer to be inserted on the next transmission

AT Command: ATFS
Binary Command: 0x3E (62 decimal)
Parameter Range: 0 - 0xFFFF [x 10 milliseconds]
Default Parameter Value: 0
Number of bytes returned: 2

**FT (Flow Control Threshold) Command**

<Serial Interfacing> The FT command is used to set/read the flow control threshold. When FT bytes have accumulated in the DI buffer (UART Receive), CTS is de-asserted or the XOFF software flow control character is transmitted.

AT Command: ATFT
Binary Command: 0x24 (36 decimal)
Parameter Range: 0 - (Input buffer size minus 0x11) [Bytes]
Default Parameter Value: Input Buffer size minus 0x11 (17 decimal)
Number of bytes returned: 2

**GD (Receive Good Count) Command**

<Diagnostics> The GD command is used to set/read the count of good received RF packets. Its parameter value is reset to 0 after every reset and is non-volatile (The parameter value does not persist in the RF module's memory after a power-up sequence). Once the "Receive Good Count" reaches its maximum value (up to 0xFFFF), it remains at its maximum count value until the maximum count value is manually changed or the modem is reset.

The GD parameter is not reset by pin, serial port or cyclic sleep modes

AT Command: ATGD
Binary Command: 0x10 (16 decimal)
Parameter Range: 0 - 0xFFFF
Default Parameter Value: 0
Number of bytes returned: 2
Related Commands: ER (Receive Error Count)

**HP (Hopping Channel) Command**

<Networking & Security> The HP command is used to set/read the RF modem's hopping channel number. A channel is one of three layers of filtration available to the modem.

In order for modems to communicate with each other, the modems must have the same channel number since each channel uses a different hopping sequence. Different channels can be used to prevent modems in one network from listening to transmissions of another.

AT Command: ATHP
Binary Command: 0x11 (17 decimal)
Parameter Range: 0 - 9
Default Parameter Value: 0
Number of bytes returned: 1
Related Commands: ID (Modem VID), DT (Destination Address), MK (Address Mask)

**HT (Time before Wake-up Initializer) Command**

<Sleep (Low Power)> The HT command is used to set/read the time of inactivity (no serial or RF data is sent or received) before a wake-up initializer is sent by a TX (transmitting) RF modem. The HT parameter should be set shorter than inactivity timeout [ST Command] time of any RX (receiving) modems operating in Cyclic Sleep (SM=4-8). The wake-up initializer sent by the TX modem instructs all RX modems to remain awake to receive RF data.

From the RX modem perspective: After HT time elapses and the inactivity timeout [ST Command] is met, the RX modem goes into cyclic sleep. In cyclic sleep, the RX modem wakes once per sleep interval [SM Command] to check for a wake-up initializer. When a wake-up initializer is detected, the modem stays awake to receive data. The wake-up initializer must be longer than the cyclic sleep interval to ensure that sleeping modems detect incoming data.

AT Command: ATHT
Binary Command: 0x03 (3 decimal)
Parameter Range: 0 - 0xFFFF [x 100 milliseconds]
Default Parameter Value: 0xFFFF (wake-up initializer will not be sent)
Number of bytes returned: 2
Related Commands: LH (Wake-up Initializer Timer), SM (Sleep Mode), ST (Time before Sleep)

When HT time elapses, the TX modem knows it needs to send a wake-up Initializer for all RX modems to remain awake and receive the next transmission.

**HV (Hardware Version) Command**

<Diagnostics> The HV command is used to read the hardware version of the RF modem.

AT Command: ATHV  
 Parameter Range: 0 - 0xFFFF [Read-only]  
 Minimum Firmware Version Required: v1.x80

**ID (Modem VID) Command**

<Networking & Security> The ID command is used to set/read the VID (Vendor Identification Number) of the RF modem. RF modems must have matching VIDs in order to communicate

AT Command: ATID  
 Binary Command: 0x27 (39 decimal)  
 Parameter Range:  
 0x11 - 0x7FFF (user-settable)  
 0 - 0x10 & 0x8000 - 0xFFFF (factory-set)  
 Default Parameter Value: 0x3332 (13106 decimal)  
 Number of bytes returned: 2

**KY (AES Encryption Key) Command**

<Networking & Security> The KY command is used to set the 256-bit AES (Advanced Encryption Standard) key for encrypting/decrypting data. Once set, the key cannot be read out of the modem by any means. The entire payload of the packet is encrypted using the key and the CRC is computed across the ciphertext. When encryption is enabled, each packet carries an additional 16 bytes to convey the random CBC Initialization Vector (IV) to the receiver(s). The KY value may be "0" or any 256-bit value (= 64 hex digits = 32 bytes). Any other value, including entering ATKY by itself with no parameters, causes an error.

AT Command: ATKY  
 Binary Command: 0x3C (60 decimal)  
 Parameter Range: 0 - (64 hex digits all set to 'F')  
 Default Parameter Value: 0 (disabled)  
 Number of bytes returned: 2  
 Number Base: Always Hexadecimal

A modem with the wrong key (or no key) will receive encrypted data, but the data driven out the serial port will be meaningless. Likewise, a modem with a key will receive unencrypted data sent from a modem without a key, but the output will be meaningless. Because CBC mode is utilized, repetitive data appears differently in different transmissions due to the randomly-generated IV.

NOTE: For international (non-U.S.) variants of 9XTend modems, the encryption key is 128-bit AES. The command operates the same except the key length is 16 bytes rather than 32 bytes. This pertains to part numbers ending with -NA or -128 (the -NA and -128 suffix mean the same thing), no matter what firmware version is loaded. This also pertains to the Australia version of firmwares 22xx, no matter what part number 9XTend it is loaded onto.

**LH (Wake-up Initializer Timer) Command**

<Sleep (Low Power)> The LH Command is used to set/read the duration of time during which the wake-up initializer is sent. When receiving modems are in Cyclic Sleep Mode, they power-down after a period of inactivity (as specified by the ST parameter) and will periodically wake and listen for transmitted data. In order for the receiving modems to remain awake, they must detect ~35ms of the wake-up initializer.

LH Command must be used whenever a receiving modem is operating in Cyclic Sleep Mode. The Wake-up Initializer Time must be longer than the cyclic sleep time that [as determined by SM (Sleep Mode) parameter]. If the wake-up initializer time were less than the Cyclic Sleep interval, the connection would be at risk of missing the wake-up initializer transmission.

AT Command: ATLH  
 Binary Command: 0x0C (12 decimal)  
 Parameter Range:  
 0 - 0xFF [x 100 milliseconds]  
 Default Parameter Value: 1  
 Number of bytes returned: 1  
 Related Commands: HT (Time before Wake-up Initializer), SM (Sleep Mode), ST (Time before Sleep)

**MD (RF Mode) Command**

<Networking & Security> The MD command is used to select/read the settings that enable the Polling and Repeater Modes on the modem.

**Polling Mode -**

A 'Polling Base' is responsible for polling remotes. A 'Polling Remote' requires a poll in order to transmit.

**Repeater Mode - A 'Repeater' re-**

**sends RF data** unless the transmission is addressed to it or if the transmission has already been detected. A 'Repeater End Node' handles repeated messages, but will not repeat the message over-the-air.

Refer to the Polling and Repeater Mode sections of the 'RF Communication Modes' chapter for more information

**MK (Address Mask) Command**

<Networking & Security> The MK command is used to set/read the Address Mask of a modem. All RF data packets contain the Destination Address of the TX (transmitting) modem. When a packet is received, the TX modem Destination Address is logically "ANDed" (bitwise) with the Address Mask of the RX (receiving) modem. The resulting value must match the Destination Address or Address Mask of the RX modem for the packet to be received and sent out the RX modem's DO (Data Out) pin. If the "ANDed" value does not match the Destination Address or Address Mask of the RX modem, the packet is discarded.

**Sniffer Mode (when MK = 0): ACK requests are ignored and every RX (receive) frame is sent to the UART**, without regard for repeated frames.

All "0" values are treated as irrelevant values and ignored.

Refer to the 'Addressing' section for more information.

**MT (Multi-transmit) Command**

<Networking & Security> The MT command is used to enable multiple transmissions of RF data packets. When Multi-transmit Mode is enabled (MT > 0), packets do not request an ACK (acknowledgement) from the receiving RF modem(s). MT takes precedence over RR, so if both MT and RR are non-zero, then MT+1 packets will be sent (with no ACK requests).

When a receiving modem receives a packet with remaining forced retransmissions, it calculates the length of the packet and inhibits transmission for the amount of time required for all retransmissions. Thereafter, a random number of delay slots are inserted between 0 and RN before transmission is allowed from the receiving modem(s).

This prevents all listening modems from transmitting at once upon conclusion of a multiple transmission event (when RN > 0).

NOTE: The actual number of forced transmissions is the parameter value plus one. For example, if MT = 1, two transmissions of each packet will be sent.

AT Command: ATMD

Binary Command: 0x31 (49 decimal)

Parameter Range: 0 – 6

Parameter	Configuration
0	Transparent Operation (Repeater Base)
1	[reserved - not used]
2	[reserved - not used]
3	Polling Base
4	Polling Remote
5	Repeater
6	Repeater End Node

Default Parameter Value: 0

Number of bytes returned: 1

Minimum Firmware Version Required: 2.x20

AT Command: ATMK

Binary Command: 0x12 (18 decimal)

Parameter Range: 0 - 0xFFFF

Default Parameter Value: 0xFFFF (65535d)

Number of bytes returned: 2

Related Commands: DT (Destination Address), HP (Hopping Channel), ID (Modem VID), MY (Source Address)

AT Command: ATMT

Binary Command: 0x3D (61 decimal)

Parameter Range: 0 - 0xFF

Default Parameter Value: 0 ( no forced

Retransmissions)

Number of bytes returned: 1

Related Commands: Networking (DT, MK, MY, RN, TT), Serial Interfacing (BR, PK, RB, RO), RF Interfacing (FS)

**MY (Source Address) Command**

<Networking & Security> The MY command is used to set/read the Source Address of the RF modem.

Refer to the DT command and the 'Addressing' section for more information.

**NB (Parity) Command**

<Serial Interfacing> The NB command is used to select/read the parity settings of the RF modem for UART communications

**PB (Polling Begin Address) Command**

<Networking & Security> PB command is used to set/read the modem's Polling Begin Address - the first address polled Polling Mode is enabled.

Polling Operations: The 'Polling Base' (MD = 3) cycles through a sequential range of addresses, polling each 'Polling Remote' (MD = 4). The base then waits for a response & proceeds to the next 'Polling Remote'. Each 'Polling Remote' responds by sending the data from the Data In buffer following the RB & RO parameters. When there is no eligible data to send, the 'Polling Remote' will not respond. The 'Polling Base' will move to the next address in the polling sequence after a short delay.

**PD (Minimum Polling Delay) Command**

<Networking & Security> The PD command is used to set/read Polling Delay (Base, MD=3) or Polling Timeout (Remote, MD=4).

**Polling Delay (Base) is the time between polling cycles.** The Polling Base will start the polling cycle after sending the first poll. After the polling cycle has completed, the timer is restarted.

**Polling Timeout (Remote) is the amount of time** the remote unit will hold data from the serial port before discarding it. Data entered within the PD time of the poll is transmitted and not discarded.

AT Command: ATMY  
Binary Command: 0x2A (42 decimal)

Parameter Range: 0 - 0xFFFF

Default Parameter Value: 0xFFFF (Disabled -

DT (Destination Address) parameter serves as both source and destination address.)

Number of bytes returned: 2

Related Commands: DT (Destination Address), HP (Hopping Channel), ID (Modem VID), MK (Address Mask)

AT Command: ATNB  
Binary Command: 0x23 (35 decimal)

Parameter Range: 0 - 4

Parameter	Configuration
0	8-bit (no parity) or 7-bit (any parity)
1	8-bit even
2	8-bit odd
3	8-bit mark
4	8-bit space

Default Parameter Value: 0

Number of bytes returned: 1

AT Command: ATPB

Binary Command: 0x45 (69 decimal)

Parameter Range: 0 - 0xFFFF

Default Parameter Value: 0

Number of bytes returned: 2

Minimum Firmware Version Required: 2.x20

Related Commands: MD (RF Mode), PE (Polling End Address), PD (Minimum Polling Delay)

AT Command: ATPD

Binary Command: 0x47 (71 decimal)

Parameter Range: 0 - 0xFFFF

(Base: [x 1ms], Remote: [x 10ms])

Default Parameter Value: 0

Number of bytes returned: 2

Minimum Firmware Version Required: 2.x20

Related Commands: MD (RF Mode), PB (Polling Begin Address), PE (Polling End Address)

**PE (Polling End Address) Command**

<Networking & Security> PE command is used to set/read the modem's Polling End Address - the last address polled when Polling Mode is enabled.

**Polling Operations:** The 'Polling Base' (MD = 3) cycles through a sequential range of addresses, polling each 'Polling Remote' (MD = 4). The base then waits for a response & proceeds to the next 'Polling Remote'. Each 'Polling Remote' responds by sending data from the DI buffer following the RB & RO parameters. When there is no eligible data to send, the 'Polling Remote' will not respond. The 'Polling Base' will move to the next address in the polling sequence after a short delay.

**PK (Maximum RF Packet Size) Command**

<RF Interfacing> The PK command is used to set/read the maximum size of RF packets transmitted from an RF modem. The maximum packet size can be used along with the RB and RO parameters to implicitly set the channel dwell time. If PK is set above 256 and BR is subsequently changed to 0, PK will automatically be lowered to 256 and a warning will be raised (refer to the BR (RF Data Rate) and WN (Warning Data) commands for details).

Changes to the PK parameter may have a secondary effect on the RB (Packetization Threshold) parameter. RB must always be less than or equal to PK. If PK is changed to a value that is less than the current value of RB, the RB value is automatically lowered to be equal to PK.

\* When BR = 0 (9600 baud), the maximum PK value is 0x100 (256d). When BR = 1 (115,200 baud), the maximum PK value is 0x800 (2048d).

**PL (TX Power Level) Command**

<RF Interfacing> The PL command is used to set/read the power level at which the RF modem transmits data

**PW (Pin Wake-up) Command**

<Sleep (Low Power)> Under normal operation, an RF modem in Cyclic Sleep Mode cycles from an active state to a low-power state at regular intervals until data is ready to be received. If the PW parameter is set to 1, the SLEEP pin (pin 8) can be used to awaken the modem from Cyclic Sleep. When the SLEEP Pin is de-asserted (low), the modem will be fully operational and will not go into Cyclic Sleep.

Once the SLEEP pin is asserted, the modem will remain active for the period of time specified by the ST (Time before Sleep) parameter and will return to Cyclic Sleep Mode (if no data is ready to be transmitted). PW Command is only valid if Cyclic Sleep has been enabled.

AT Command: ATPE

Binary Command: 0x46 (70 decimal)

Parameter Range: 0 - 0xFFFF

Default Parameter Value: 0

Number of bytes returned: 2

Minimum Firmware Version Required: 2.x20

Related Commands: MD (RF Mode), PB (Polling Begin Address), PD (Minimum Polling Delay)

AT Command: ATPK

Binary Command: 0x29 (41 decimal)

Parameter Range: 1 - 0x800 [Bytes]

Default Parameter Value: 0x100\* or 0x800\* (256 or 2048 decimal)

Number of bytes returned: 2

Related Commands: BR (RF Data Rate) RB (Packetization Threshold), RO (Packetization Timeout), WN (Warning D)

AT Command: ATPL

Binary Command: 0x3A (58 decimal)

Parameter Range: 0 - 4

Parameter	Configuration
0	1 mW
1	10 mW
2	100 mW
3	500 mW
4	1000 mW (1 Watt)

Default Parameter Value: 4

Number of bytes returned: 1

AT Command: ATPW

Binary Command: 0x1D (29 decimal)

Parameter Range: 0 - 1

Parameter	Configuration
0	Disabled
1	Enabled

Default Parameter Value: 0

Number of bytes returned: 1

Related Commands: SM (Sleep Mode), ST (Time before Sleep)

**RB (Packetization Threshold) Command**

<Serial Interfacing> The RB command is used to set/read the character threshold value. RF transmission begins after data is received in the Input Buffer and either of the following criteria is met:

- RB characters received by the UART
- RO character times of silence detected on the UART receive lines (after receiving at least 1 Byte of data)

If PK (Max. RF Packet Size) is lowered below the value of RB, RB is automatically lowered to match the PK value. If (RO = 0), RB bytes must be received before beginning transmission.

**Note:** RB and RO criteria only apply to the first packet of a multi-packet transmission. If data remains in the Input Buffer after the first packet, transmissions will continue in a streaming manner until there is no data left in the Input Buffer (UART receive buffer).

AT Command: ATRB
Binary Command: 0x20 (32 decimal)
Parameter Range: 0 - PK parameter value (up to 0x800 Bytes)
Default Parameter Value: 0x800 Bytes
Number of bytes returned: 2
Related Commands: BR (RF Data Rate), PK (RF Packet Size), RO (Packetization Timeout)

**RC (Ambient Power - Single Channel) Command**

<Diagnostics> The RC command is used to examine and report the power level on a given channel.

Sample output: -78 dBm [when CF = 0]  
 4e [when CF = 1]  
 -78 [when CF = 2]

AT Command: ATRC
Parameter Range: (read-only): 0 - 0x31 [dBm]
Number of bytes returned: 1
Related Commands: RM (Ambient Power - All Channels)

**RE (Restore Defaults) Command**

<Diagnostics> The RE command is used to restore all configurable parameters to their factory default settings.

The RE Command does not cause default values to be stored to nonvolatile (persistent) memory. For the restored default settings to persist in the modem's non-volatile memory and be saved in the event of RF modem reset or power-down, the WR (Write) command must be issued prior to power-down or reset.

AT Command: ATRE
Binary Command: 0x0E (14 decimal)

**RM (Ambient Power - All Channels) Command**

<Diagnostics> The RM command is used to examine and report power levels on all channels. If no parameter is given, the channels are scanned one time. If a parameter is given, the channels are repeatedly scanned for that number of seconds. The maximum power level seen for each channel is reported (i.e. peak hold).

A graphical spectrum analyzer can be implemented by repeatedly sending the RM command (with no arguments) and reading the resultant 50 power levels (this is easiest to do when CF = 1 or 2).

Sample output [when CF = 0]:            Ch 0: -100 dBm  
    Ch 1: -103 dBm  
    ...  
    Ch 49: -99 dBm

Sample output [when CF = 1]:            64  
    67  
    ...  
    63

Sample output [when CF = 2]:            100  
    -103

AT Command: ATRM
Parameter Range: no parameter - 0x7D0
Number of bytes returned: 2
Related Commands: RC (Ambient Power - Single channel)

**RN (Delay Slots) Command**

<Networking & Security> The RN command is used to set/read the time delay that the transmitting RF modem inserts before attempting to resend a packet. If the transmitting modem fails to receive an acknowledgement after sending a packet, it inserts a random number of delay slots (ranging from 0 to (RN minus 1)) before attempting to resend the packet. Each delay slot is 5 msec (when BR=1) and 54 msec (when BR=0).

If two modems attempt to transmit at the same time, the random time delay after packet failure allows only one modem to transmit the packet successfully; while the other modem waits until the channel available for RF transmission.

RN Command is only applicable if retries have been enabled [RR (Retries) Command] or if forced delays will be inserted into a transmission [TT (Streaming Limit) Command]

AT Command: ATRN
Binary Command: 0x19 (25 decimal)
Parameter Range: 0xFF [38 ms slots]
Default Parameter Value: 0 (no delay slots inserted)
Number of bytes returned: 1
Related Commands: RR (Retries), TT (Streaming Limit)

**RO (Packetization Timeout) Command**

<Serial Interfacing> The RO command is used to set/read the Packetization Timeout setting. RF transmission begins when data is in the Input buffer and either of the following criteria are met:

- RO character times of silence on the UART receive lines (after receiving at least 1 byte)
- RB characters have been received by the UART

RB and RO criteria only apply to the first packet of a multipacket transmission. If data remains in the Input Buffer (UART receive) after the first packet, transmissions will continue in a streaming manner until there is no data left in the Input Buffer.

**When RO is the transmission-**

**beginning criteria:** The actual time between the reception of the last character from the UART and the beginning of RF transmission will be at least 800 µsec longer than the actual RO time to allow for transmission setup. Additionally, it is subject to 100-200 µsec of additional uncertainty, which could be significant for small values of RO at high UART bit rates.

The correct UART character time (10, 11, or 12 bits) is calculated based on the following criteria:

- 1 start bit
- 8 data bits
- 0 or 1 parity bit [as determined by the NB (Parity) Command]
- 1 or 2 stop bits [as determined by SB (Stop Bits) Command]

**RP (RSSI PWM Timer) Command**

<Diagnostics> RP Command is used to enable a PWM ("Pulse Width Modulation") output on the Config/RSSI pin (pin 11 of the RF Modem). The pin is calibrated to show the difference between received signal strength and the sensitivity level of the RF modem. PWM pulses vary from zero to 95 percent. Zero percent means the received RF signal is at or below the published sensitivity level of the module.

The following table shows dB levels above sensitivity and PWM values (The total time period of the PWM output is 8.32 ms. PWM output consists of 40 steps and therefore the minimum step size is 0.208 ms.):

AT Command: ATRP
Binary Command: 0x22 (34 decimal)
Parameter Range: 0 - 0xFF [x 100 milliseconds]
Default Parameter Value: 0x20 (32d)
Number of bytes returned: 1

dB above Sensitivity	PWM percentage (high period / total period)
10	20%
20	35%
30	50%

A non-zero value defines the time that PWM output is active with the RSSI value of the last received RF packet. After the set time when no RF packets are received, PWM output is set low (0 percent PWM) until another RF packet is received. PWM output is also set low at power-up. A parameter value of 0xFF permanently enables PWM output and always reflects the value of the last received RF packet.

The Config/RSSI pin is shared between PWM output and Config input. When the modem is powered, the Config pin is an input. During the power-up sequence, if RP parameter is a non-zero value, the Config pin is configured as an output and set low until the first RF packet is received.

With a non-zero RP parameter, the Config pin is an input for RP ms after power up.

**RR (Retries) Command**

<Networking & Security> The RR command is used to set/read the maximum number of retries sent for a given RF packet. When RR Command is enabled (RR>0), RF packet retries and ACKs (acknowledgements) are enabled.

Exceptions: If the MT command is enabled (MT>0) or if a broadcast Destination Address is used (DT = 0xFFFF); RF packet retries and ACKs are disabled.

After transmitting a packet, the transmitting RF modem waits to receive an acknowledgement from a receiving modem. If the acknowledgement is not received in the period of time specified by RN (Delay Slots) Command, the original packet is transmitted again. The RF packet is transmitted repeatedly until an acknowledgement is received or until the packet is sent RR times.

---

AT Command: ATRR

---

Binary Command: 0x18 (24 decimal)

---

Parameter Range: 0 - 0xFF

---

Default Parameter Value: 0x0A (10d)

---

Number of bytes returned: 1

---

**RT (GPI1 Configuration) Command**

<Serial Interfacing> The RT command is used to set/read the behavior of the GPI1 pin (pin 10) of the RF Modem. The pin can be configured to enable binary programming or RTS flow control.

---

AT Command: ATRT

---

Binary Command: 0x16 (22 decimal)

---

Parameter Range: 0 – 2

---

Parameter	Configuration
0	Disabled
1	Enable Binary Programming
2	Enable RTS Flow Control

---

Default Parameter Value: 0

---

Number of bytes returned: 1

---

IdCdS(SId)S

---

**SB (Stop Bits) Command**

<Serial Interfacing> The SB Command is used to set/read the number of stop bits in the data packet.

---

AT Command: ATSB

---

Binary Command: 0x37 (55 decimal)

---

Parameter Range: 0 – 1

---

Parameter	Configuration
0	1 stop bit
1	2 stop bits

---

Default Parameter Value: 0

---

Number of bytes returned: 1

---

**SH (Serial Number High) Command**

<Diagnostics> SH Command is used to set/read the serial number high word of the RF modem.

---

AT Command: ATSH

---

Binary Command: 0x25 (37 decimal)

---

Parameter Range (read-only): 0 - 0xFFFF

---

Default Parameter Value: varies

---

Number of bytes returned: 2

---

Related Commands: SL (Serial Number Low)

---

**SL (Serial Number Low) Command**

<Diagnostics> SL Command is used to set/read the serial number low word of the RF modem.

---

AT Command: ATSL

---

Binary Command: 0x26 (38 decimal)

---

Parameter Range (read-only): 0 - 0xFFFF

---

Default Parameter Value: varies

---

Number of bytes returned: 2

---

Related Commands: SH (Serial Number High)

---

**SM (Sleep Mode) Command**

<Sleep Mode (Low Power)> The SM Command is used to set/read the RF mode m's Sleep Mode settings that configure the modem to run in states that require minimal power consumption.

For more information regarding Sleep Modes, refer to the Sleep Mode sections

---

AT Command: ATSM

---

Binary Command: 0x01 (1 decimal)

---

Parameter Range: 0 – 8 (3 is reserved)

---

Parameter	Configuration
0	Disabled
1	Pin Sleep
2	Serial Port Sleep
3	[reserved]
4	Cyclic 1.0 second sleep (RF module wakes every 1.0 seconds)
5	Cyclic 2.0 second sleep
6	Cyclic 4.0 second sleep
7	Cyclic 8.0 second sleep
8	Cyclic 16.0 second sleep

---

Default Parameter Value: 0

---

Number of bytes returned: 1

---

Related Commands:  
 Pin Sleep - PC (Power-up Mode), PW (Pin Wake-up)  
 Serial Port Sleep - ST (Time before Sleep)  
 Cyclic Sleep - ST (Time before Sleep), LH (Wake-up Initializer Timer), HT (Time Before Wake-up Initializer), PW (Pin Wake-up)

---

**ST (Time before Sleep) Command**

<Sleep Mode (Low Power)> The ST Command is used to set/read the period of time (in milliseconds) in which the RF modem remains inactive before entering Sleep Mode.

For example, if the ST Parameter is set to 0x64 (100 decimal), the module will enter into Sleep mode after 10 seconds of inactivity (no transmitting or receiving).

This command can only be used if Cyclic Sleep or Serial Port Sleep Mode setting s have been selected using SM (Sleep Mode) Command.

---

AT Command: ATST

---

Binary Command: 0x02 (2 decimal)

---

Parameter Range: (ATAT+3) - 0x7FFF  
 [x 100 milliseconds]

---

Default Parameter Value: 0x64 (100 decimal)

---

Number of bytes returned: 2

---

Related Commands: SM (Sleep Mode), LH (Wake-up Initializer Timer), HT (Time before Wake-up Initializer)

---

**TP (Board Temperature) Command**

<Diagnostics> TP Command is used to read the current temperature of the board.

Sample Output: 26 C [when ATCF = 0]  
 1A [when ATCF = 1]  
 26 [when ATCF = 2].

AT Command: ATTP
Binary Command: 0x38 (56 decimal)
Parameter Range (read-only): 0- 0x7F
Number of bytes returned: 1
Related Command: WN (Warning Data)

**TR (Transmit Error Count) Command**

<Diagnostics> The TR command is used to report the number of retransmit failures. This number is incremented each time a packet is not acknowledged within the number of retransmits specified by the RR (Retries) parameter. The number of packets therefore are counted that were not successfully received and subsequently discarded.

The TR parameter is not non-volatile and is reset to zero when the RF modem is reset.

AT Command: ATTR
Binary Command: 0x1B (27 decimal)
Parameter Range: 0- 0xFFFF
Default Parameter Value: 0
Number of bytes returned: 2
Related Command: RR (Retries)

**TT (Streaming Limit) Command**

<Networking & Security> The TT command is used to set/read the limit on the number of bytes that can be sent out before a random delay is issued.

If an RF modem is sending a continuous stream of RF data, a delay is inserted which stops its transmission and allows other modems time to transmit (once it sends TT bytes of data). Inserted random delay lasts between 1 & 'RN + 1' delay slots, where each delay slot lasts 38 ms.

The TT command can be used to simulate full-duplex behavior.

AT Command: ATTT
Binary Command: 0x1A (26 decimal)
Parameter Range: 0- 0xFFFF
Default Parameter Value: 0 (disabled)
Number of bytes returned: 2
Related Command: RN (Delay Slots)

**TX (Transmit Only)**

<RF Interfacing> The TX command is used to set/read the transmit/receive behaviors of the RF modem. Setting a module to TX-only (TX = 1) may reduce latency because the transmitting modem will never be confined to receiving data from other modems.

AT Command: ATTX						
Binary Command: 0x3F (63 decimal)						
Parameter Range: 0 – 1						
<table border="1"> <thead> <tr> <th>Parameter</th> <th>Configuration</th> </tr> </thead> <tbody> <tr> <td>0</td> <td>TX &amp; RX</td> </tr> <tr> <td>1</td> <td>TX-only</td> </tr> </tbody> </table>	Parameter	Configuration	0	TX & RX	1	TX-only
Parameter	Configuration					
0	TX & RX					
1	TX-only					
Default Parameter Value: 0						
Number of bytes returned: 1						

**VL (Firmware Version - Verbose)**

<Diagnostics> The VL command is used to read the verbose firmware version of the RF modem.

AT Command: ATVL
Parameter Range: returns string
Default Parameter Value: 0
Number of bytes returned: 2

**VR (Firmware Version - Short) Command**

<Diagnostics> The VR command is used to read the firmware version of the RF modem.

Note: Firmware versions contain four significant digits - "A.B.C.D". If B=2, the modem is programmed for operation in Australia only.

AT Command: ATVR
Binary Command: 0x14 (20 decimal)
Parameter Range (read-only): 0 - 0xFFFF
Number of bytes returned: 2

**WA (Active Warning Numbers) Command**

AT Command: ATWA

Parameter Range: Returns string - one warning number per line.

<Diagnostics> The WA command reports the warning numbers of all active warnings - one warning number per line. No further information is shown and warning counts are not reset.

Sample Output (indicates warnings 1 and 3 are currently active): 1

3  
OK

**WN (Warning Data) Command**

AT Command: ATWN

Parameter Range: Returns string

<Diagnostics> WN command is used to report the following data for all active and sticky warnings:

- Warning number & description
- Number of occurrences since the last WN or WS command
- Whether the warning is currently active

Warnings, which are not currently active and have not been active since the last issuance of the WN or WS commands, are not displayed. The WN command also resets all non-zero warning counts; except for warnings that are presently active, which are set to 1.

Sample output: Warning 4: Over-temperature

5 occurrences; presently inactive.

Warning #	Description
1	Under-voltage. This is caused if the supply voltage falls below the minimum threshold for the lowest power level (2.8 V). If/when the voltage rises above the threshold, the warning is deactivated. The modem will not transmit below this voltage threshold.
2	Over-voltage. This is caused if the supply voltage exceeds 5.75 V. Transmission is not allowed while this warning is active.
3	Under-temperature. This is caused if the temperature sensed by the modem is less than -40 C. The modem does not artificially limit operation while this warning is active, but modem functionality is not guaranteed.
4	Over-temperature. This is caused if the temperature sensed by the modem is greater than 105 C. The modem does not allow transmission nor reception while this warning is active. The warning is deactivated when the temperature falls to 100 C.
5	Power reduced. This is caused if the transmit power has to be reduced from the level programmed by PL Command due to insufficient supply voltage. The 1 W power level requires 4.75 V or higher; 500 mW requires 3.0 V or higher; 100 mW, 10 mW and 1 mW require 2.8 V or higher.
6	Default calibration data in flash. This is caused if the modem-specific power calibration data is either not present or is invalid, or if none of the parameters have been modified from their default values. Power levels may be incorrect.
7	Default configuration parameters in flash. This is caused if user-modifiable parameters (i.e. those stored by a 'WR' command) in flash are all the compiled-in default values. This is caused if the user configuration is found to be not present or invalid at power-up and there is no custom configuration, or if no user-modifiable parameters have been modified from the compiled-in defaults. Modification of one or more parameters without the subsequent WR to commit the changes to flash will not deactivate this warning, since it reflects the status of the parameters in flash. Note that this warning does not reflect usage of the custom configuration defaults, only usage of the compiled-in defaults.
8	Default factory configuration parameters in flash. This is caused if the factory parameters in flash are all the default values. This is caused if the factory configuration is found to be not present or invalid at power-up, or if no factory parameters have been modified.

**WR (Write) Command**

AT Command: ATWR

Binary Command: 0x08 (8 decimal)

<(Special)> The WR command is used to write configurable parameters to non-volatile memory (Values remain in the module's memory until overwritten by another use of WR Command).

If changes are made without writing them to non-volatile memory, the module will revert back to previously saved parameters the next time the module is powered-on.

If the non-volatile user configuration is not correct, WR will re-attempt (up to 3x). If all three attempts fail, the command will return an ERROR alert.

**WS (Sticky Warning Numbers) Command**

<Diagnostics> The WS command reports warning numbers of all warnings active since the last use of the WS or WN command (including any warnings which are currently active). This command also resets all non-zero warning counts, except for warnings that are presently active, which are set to 1.

AT Command: ATWS

Parameter Range (read-only): 1 – 8

Number of bytes returned: 1

**API Operation**

By default, Zlinx Xtreme Radio Modems act as a serial line replacement (Transparent Operation) - all UART data received through the DI pin is queued up for RF transmission. When the modem receives an RF packet, the data is sent out the DO pin with no additional information.

Inherent to Transparent Operation are the following behaviors:

- If modem parameter registers are to be set or queried, a special operation is required for transitioning the modem into Command Mode.
- In point-to-multipoint systems, the application must send extra information so that the receiving modem(s) can distinguish between data coming from different remotes.

As an alternative to the default Transparent Operation, API (Application Programming Interface) Operations are available. API operation requires that communication with the modem be done through a structured interface (data is communicated in frames in a defined order). The API specifies how commands, command responses and modem status messages are sent and received from the modem using a UART Data Frame.

**API Frame Specifications**

Two API modes are supported and both can be enabled using the AP (API Enable) command. Use the following AP parameter values to configure the modem to operate in a particular mode:

- AP = 0 (default): Transparent Operation (UART Serial line replacement) API modes are disabled.
- AP = 1: API Operation
- AP = 2: API Operation (with escaped characters)

Any data received prior to the start delimiter is silently discarded. If the frame is not received correctly or if the checksum fails, the data is silently discarded.

**API Operation (AP Parameter = 1)**

When this mode is enabled (AP=1), the UART data frame and structure is defined as follows:



MSB = Most Significant Byte, LSB = Least Significant Byte

**API Operation - with Escape Characters (AP parameter = 2)**

When this API mode is enabled (AP = 2), the UART data frame structure is defined as follows:



MSB = Most Significant Byte, LSB = Least Significant Byte

**Escape characters.** When sending or receiving a UART data frame, specific data values must be escaped (flagged) so they do not interfere with the UART or UART data frame operation. To escape an interfering data byte, insert 0x7D and follow it with the byte to be escaped XOR'd with 0x20.

Data bytes that need to be escaped:

- 0x7E – Frame Delimiter
- 0x7D – Escape
- 0x11 – XON
- 0x13 – XOFF

**EXAMPLE:** Raw UART Data Frame (before escaping interfering bytes): 0x7E 0x00 0x02 0x23 0x11 0xCB  
 0x11 needs to be escaped which results in the following frame:  
 0x7E 0x00 0x02 0x23 0x7D 0x31 0xCB

**NOTE** In the above example, the length of the raw data (excluding the checksum) is 0x0002 and the checksum of the non-escaped data (excluding frame delimiter and length) is calculated as:

$$0xFF - (0x23 + 0x11) = (0xFF - 0x34) = 0xCB.$$

**Checksum:** To test data integrity, a checksum is calculated and verified on non-escaped data.

**To calculate:** Not including frame delimiters and length, add all bytes keeping only the lowest 8 bits of the result and subtract from 0xFF.

**To verify:** Add all bytes (include checksum, but not the delimiter and length). If the checksum is correct, the sum will equal 0xFF.

## API Types

Frame data of the UART data frame forms an API-specific structure as follows:

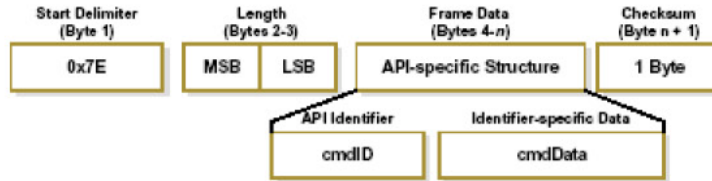

The cmdID frame (API-identifier) indicates which API messages will be contained in the cmdData frame (Identifier-specific data). Refer to the sections that follow for more information regarding the supported API types. Note that multi-byte values are sent big endian.

### Modem Status

API Identifier: 0x8A

RF modem status messages are sent from the modem in response to specific conditions.

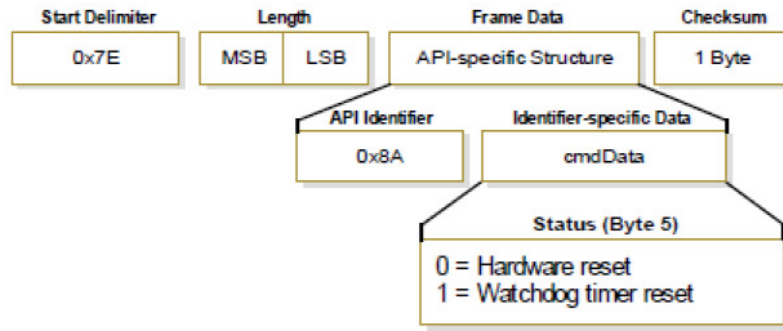

**TX (Transmit) Request: 16-bit address**

API Identifier Value: 0x01

A TX Request message will cause the modem to send RF Data as an RF Packet.

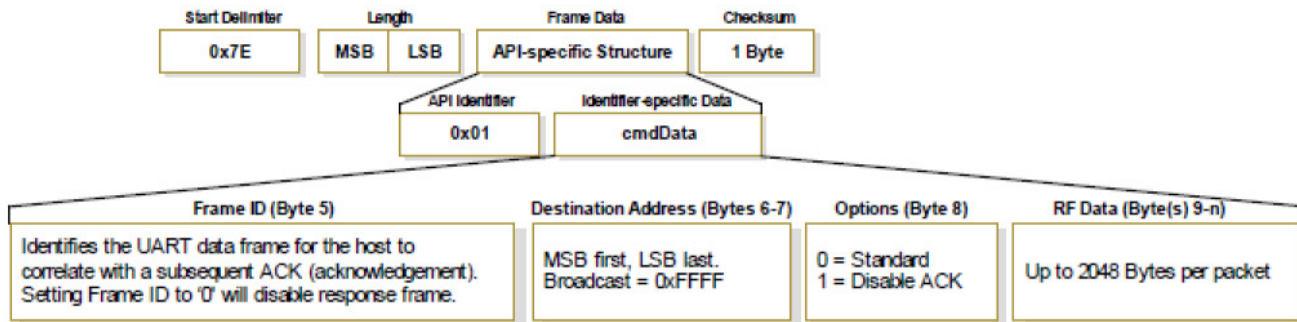
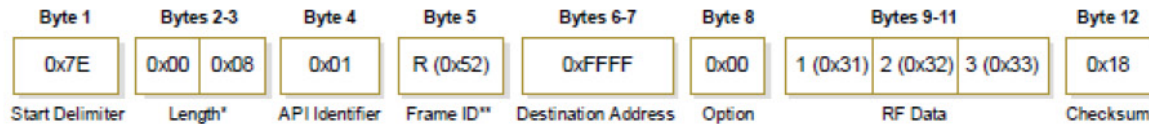

Figure 1 TX Packet (16-bit address) Frames



\* Length [Bytes] = API Identifier + Frame ID + Option + RF Data

\*\* "R" value was arbitrarily selected

**TX (Transmit) Status**

API Identifier Value: 0x89

When a TX Request is completed, the module sends a TX Status message. This message will indicate if the packet was transmitted successfully or if there was a failure.

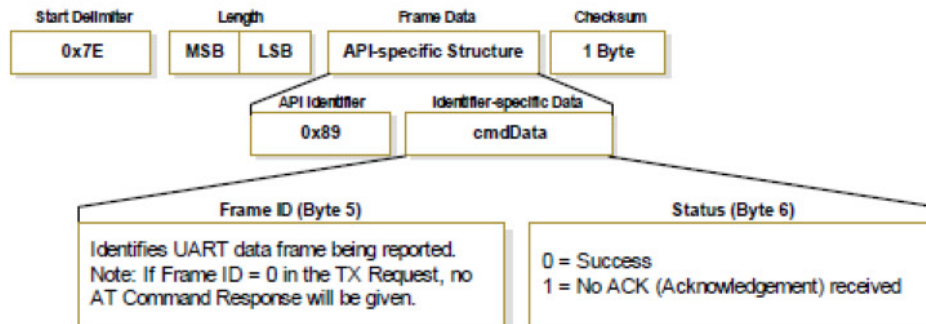

NOTE: "STATUS = 1" occurs when all retries are expired and no ACK is received.

"STATUS = 3" occurs when a packet is purged due to a 'Polled Remote' not receiving a poll.

**RX (Receive) Packet: 16-bit address**

API Identifier Value: 0x81

When the module receives an RF packet, it is sent out the UART using this message type.

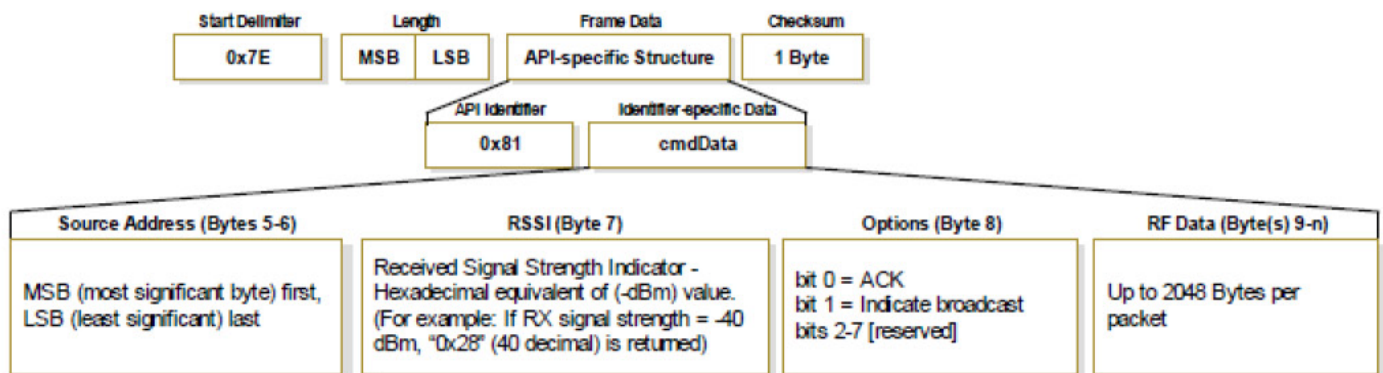

**6.5 ZXT24-RM CONFIGURATION**

**6.5.1 ADVANCED PROGRAMMING**

**Setup**

The programming examples in this section require the installation of a hyper terminal program and a serial connection to a PC. (B&B stocks RS-232 and USB boards to facilitate interfacing with a PC.)

Mount the RF module to an interface board, then connect the module assembly to a PC. Launch the terminal software and select the 'PC Settings' tab. Verify the baud and parity settings of the Com Port match those of the RF module.

NOTE: Failure to enter AT Command Mode is most commonly due to baud rate mismatch. Ensure the 'Baud' setting on the 'PC Settings' tab matches the interface data rate of the RF module. By default, the BD parameter = 3 (which corresponds to 9600 bps).

***Sample Config: Modify RF Destination Address***

'CR' stands for carriage return:

**Method 1 (One line per command)**

Send AT Command +++ ATDL <Enter> ATDL1A0D <Enter> ATWR <Enter> ATCN <Enter>	System Response_ OK <CR> (Enter into Command Mode) {current value} <CR> (Read Destination Address Low) OK <CR> (Modify Destination Address Low) OK <CR> (Write to non-volatile memory) OK <CR> (Exit Command Mode)
--	---

**Method 2 (Multiple commands on one line)**

Send AT Command_ +++ ATDL <Enter> ATDL1A0D,WR,CN <Enter>	System Response_ OK <CR> (Enter into Command Mode) {current value} <CR> (Read Destination Address Low) OK, OK, OK <CR> (Command execution is triggered upon each instance of the comma)
---	--

## Command Reference Table

Zlinx Radio Modems expect numerical values in hexadecimal. Hexadecimal values are designated

by a "0x" prefix. Decimal equivalents are designated by a "d" suffix.

Commands are contained

within the following command categories (listed in the order that their tables appear):

- Special
- Networking & Security
- RF Interfacing
- Sleep (Low Power)
- Serial Interfacing
- I/O Settings
- Diagnostics
- AT Command Options

All modules within a PAN should operate using the same firmware version.

### Commands-Special

AT_ Command	Command _ Category	Name and Description	Parameter Range	Default
WR	Special	Write. Write parameter values to non-volatile memory so that parameter modifications persist through subsequent power-up or reset. Note: Once WR is issued, no additional characters should be sent to the module until after the response "OK\r" is received.	-	-
RE	Special	Restore Defaults. Restore module parameters to factory defaults.	-	-
FR (v1.x80*)	Special	Software Reset. Responds immediately with an OK then performs a hard reset ~100ms later.	-	-

\*Firmware version in which the command was first introduced (firmware versions are numbered in hexadecimal notation.)

### Commands-Networking & Security (Sub categories designated within {brackets})

AT_ Command	Command _ Category	Name and Description	Parameter Range	Default
CH	Networking {Addressing}	Channel. Set/Read the channel number used for transmitting and receiving data between RF modules (uses 802.15.4 protocol channel numbers).	0x0B - 0x1A 0x0C - 0x17	0x0C (12d)
ID	Networking {Addressing}	PAN ID. Set/Read the PAN (Personal Area Network) ID. Use 0xFFFF to broadcast messages to all PANs.	0 - 0xFFFF	0x3332_ (13106d)

DH	Networking {Addressing}	Destination Address High. Set/Read the upper 32 bits of the 64-bit destination address. When combined with DL, it defines the destination address used for transmission. To transmit using a 16-bit address, set DH parameter to zero and DL less than 0xFFFF. 0x000000000000FFFF is the broadcast address for the PAN.	0 - 0xFFFFFFFF	0
DL	Networking {Addressing}	Destination Address Low. Set/Read the lower 32 bits of the 64-bit destination address. When combined with DH, DL defines the destination address used for transmission. To transmit using a 16-bit address, set DH parameter to zero and DL less than 0xFFFF. 0x000000000000FFFF is the broadcast address for the PAN.	0 - 0xFFFFFFFF	0
MY	Networking {Addressing}	16-bit Source Address. Set/Read the RF module 16-bit source address. Set MY = 0xFFFF to disable reception of packets with 16-bit addresses. 64-bit source address (serial number) and broadcast address (0x000000000000FFFF) is always enabled.	0 - 0xFFFF	0
SH	Networking {Addressing}	Serial Number High. Read high 32 bits of the RF module's unique IEEE 64-bit address. 64-bit source address is always enabled.	0 - 0xFFFFFFFF [read-only]	Factory-set
SL	Networking {Addressing}	Serial Number Low. Read low 32 bits of the RF module's unique IEEE 64-bit address. 64-bit source address is always enabled.	0 - 0xFFFFFFFF [read-only]	Factory-set
RR (v1.xA0*)	Networking {Addressing}	Retries. Set/Read the maximum number of retries the module will execute in addition to the 3 retries provided by the 802.15.4 MAC. For each retry, the 802.15.4 MAC can execute up to 3 retries.	0 - 6	0
RN	Networking {Addressing}	Random Delay Slots. Set/Read the minimum value of the back-off exponent in the CSMA-CA algorithm that is used for collision avoidance. If RN = 0, collision avoidance is disabled during the first iteration of the algorithm (802.15.4 - macMinBE).	0 - 3 [exponent]	0
MM (v1.x80*)	Networking {Addressing}	MAC Mode. Set/Read MAC Mode value. MAC Mode enables/disables the use of a B&B header in the 802.15.4 RF packet. When Mode 0 is enabled	0 - 2 0 = 1 = B&B Mode 1 = 802.15.4 (no ACKs)	0

		(MM=0), duplicate packet detection is enabled as well as certain AT commands. Modes 1 and 2 are strict 802.15.4 modes.	2 =802.15.4 (with ACKs)	
NI (v1.x80*)	Networking {Identification}	Node Identifier.Stores a string identifier. The register only accepts printable ASCII data. A string can not start with a space. Carriage return ends command. Command will automatically end when maximum bytes for the string have been entered. This string is returned as part of the ND (Node Discover) command. This identifier is also used with the DN (Destination Node) command.	20-character ASCII string	-
ND (v1.x80*)	Networking {Identification}	Node Discover.Discovers and reports all RF modules found. The following information is reported for each module discovered (the example cites use of Transparent operation (AT command format) - refer to the long ND command description regarding differences between Transparent and API operation). MY<CR> SH<CR> SL<CR> DB<CR> NI<CR><CR> The amount of time the module allows for responses is determined by the NT parameter. In Transparent operation, command completion is designated by a <CR> (carriage return). ND also accepts a Node Identifier as a parameter. In this case, only a module matching the supplied identifier will respond.	Optional 20-character NI value	
NT (v1.xA0*)	Networking {Identification}	Node Discover Time.Set/Read the amount of time a node will wait for responses from other nodes when using the ND (Node Discover) command.	0x01 - 0xFC	0x19
DN (v1.x80*)	Networking {Identification}	Destination Node. Resolves an NI (Node Identifier) string to a physical address. The following events occur upon successful command execution: 1. DL and DH are set to the address of the module with the matching Node Identifier. 2. "OK" is returned. 3. RF module automatically exits AT Command Mode if there is no	20-character ASCII string	-

		response from a module within 200 msec or a parameter is not specified (left blank), the command is terminated and an "ERROR" message is returned.		
CE (v1.x80*)	Networking {Association}	Coordinator Enable. Set/Read the coordinator setting.	0 - 1 0 = End Device_ 1 = Coordinator	0
SC (v1.x80*)	Networking {Association}	Scan Channels. Set/Read list of channels to scan for all Active and Energy Scans as a bitfield. This affects scans initiated in command mode (AS, ED) and during End Device Association and Coordinator startup: bit 0 - 0x0B bit 4 - 0x0F bit 8 - 0x13 bit 12 - 0x17 bit 1 - 0x0C bit 5 - 0x10 bit 9 - 0x14 bit 13 - 0x18 bit 2 - 0x0D bit 6 - 0x11 bit 10 - 0x15 bit 14 - 0x19 bit 3 - 0x0E bit 7 - 0x12 bit 11 - 0x16 bit 15 - 0x1A	0 - 0xFFFF [bitfield]	0x1FFE
SD (v1.x80*)	Networking {Association}	Scan Duration. Set/Read the scan duration exponent. <i>End Device</i> - Duration of Active Scan during Association. On beacon system, set SD = BE of coordinator. SD must be set at least to the highest BE parameter of any Beaconsing Coordinator with which an End Device or Coordinator wish to discover. <i>Coordinator</i> : If 'ReassignPANID' option is set on Coordinator [refer to A2 parameter], SD determines the length of time the Coordinator will scan channels to locate existing PANs. If 'ReassignChannel' option is set, SD determines how long the Coordinator will perform an Energy Scan to determine which channel it will operate on. 'Scan Time' is measured as (# of channels to scan) * (2 ^ SD) * 15.36ms). The number of channels to scan is set by the SC command. The modem can scan up to 16 channels (SC = 0xFFFF). Example: The values below show results for a 13 channel scan: If SD = 0, time = 0.18 sec SD = 8, time = 47.19 sec SD = 2, time = 0.74 sec SD = 10, time = 3.15 min SD = 4, time = 2.95 sec SD = 12, time = 12.58 min	0-0x0F [exponent]	4

		SD = 6, time = 11.80 sec SD = 14, time = 50.33 min		
A1 (v1.x80*)	Networking {Association}	<p>End Device Association. Set/Read End Device association options.</p> <p>bit 0 - ReassignPanID 0 - Will only associate with Coordinator operating on PAN ID that matches module ID 1 - May associate with Coordinator operating on any PAN ID</p> <p>bit 1 – ReassignChannel 0 - Will only associate with Coordinator operating on matching CH Channel setting 1 - May associate with Coordinator operating on any Channel</p> <p>bit 2 – AutoAssociate 0 - Device will not attempt Association 1 - Device attempts Association until success</p> <p>Note: This bit is used only for Non-Beacon systems. End Devices in Beacon-enabled system must always associate to a Coordinator</p> <p>bit 3 – PollCoordOnPinWake 0 - Pin Wake will not poll the Coordinator for indirect (pending) data 1 - Pin Wake will send Poll Request to Coordinator to extract any pending data bits 4 - 7 are reserved</p>	0 - 0x0F [bitfield]	0
A2 (v1.x80*)	Networking {Association}	<p>Coordinator Association. Set/Read Coordinator association options.</p> <p>bit 0 – ReassignPanID 0 - Coordinator will not perform Active Scan to locate available PAN ID. It will operate on ID (PAN ID). 1 - Coordinator will perform Active Scan to determine an available ID (PAN ID). If a PAN ID conflict is found, the ID parameter will change.</p> <p>bit 1 - ReassignChannel – 0 - Coordinator will not perform Energy Scan to determine free channel. It will operate_ on the channel determined by the CH parameter.</p>	0 - 7 [bitfield]	0

		<p>1 - Coordinator will perform Energy Scan to find a free channel, then operate on that channel.</p> <p>bit 2 - AllowAssociation –</p> <p>0 - Coordinator will not allow any devices to associate to it.</p> <p>1 - Coordinator will allow devices to associate to it.</p> <p>bits 3 - 7 are reserved</p>		
AI (v1.x80*)	Networking {Association}	<p>Association Indication. Read errors with the last association request:</p> <p>0x00 - Successful Completion - Coordinator successfully started or End Device association complete</p> <p>0x01 - Active Scan Timeout</p> <p>0x02 - Active Scan found no PANs</p> <p>0x03 - Active Scan found PAN, but the CoordinatorAllowAssociation bit is not set</p> <p>0x04 - Active Scan found PAN, but Coordinator and End Device are not configured to support beacons</p> <p>0x05 - Active Scan found PAN, but the Coordinator ID parameter does not match the ID parameter of the End Device</p> <p>0x06 - Active Scan found PAN, but the Coordinator CH parameter does not match the CH parameter of the End Device</p> <p>0x07 - Energy Scan Timeout</p> <p>0x08 - Coordinator start request failed</p> <p>0x09 - Coordinator could not start due to invalid parameter</p> <p>0x0A - Coordinator Realignment is in progress</p> <p>0x0B - Association Request not sent</p> <p>0x0C - Association Request timed out - no reply was received</p> <p>0x0D - Association Request had an Invalid Parameter</p> <p>0x0E - Association Request Channel Access Failure. Request was not transmitted - CCA failure</p> <p>0x0F - Remote Coordinator did not send an ACK after Association Request was sent</p> <p>0x10 - Remote Coordinator did not reply to the Association</p>	0 - 0x13 [read-only]	-

		Request, but an ACK was received after sending the request 0x11 - [reserved] 0x12 - Sync-Loss - Lost synchronization with a Beacons Coordinator 0x13 - Disassociated - No longer associated to Coordinator		
DA (v1.x80*)	Networking {Association}	Force Disassociation. End Device will immediately disassociate from a Coordinator (if associated) and reattempt to associate.	-	-
FP (v1.x80*)	Networking {Association}	Force Poll. Request indirect messages being held by a coordinator.	-	-
AS (v1.x80*)	Networking {Association}	Active Scan. Send Beacon Request to Broadcast Address (0xFFFF) and Broadcast PAN (0xFFFF) on every channel. The parameter determines the time the radio will listen for Beacons on each channel. A PanDescriptor is created and returned for every Beacon received from the scan. Each PanDescriptor contains the following information: CoordAddress (SH, SL)<CR> CoordPanID (ID)<CR> CoordAddrMode <CR> 0x02 = 16-bit Short Address 0x03 = 64-bit Long Address _ Channel (CH parameter) <CR> _ SecurityUse<CR> _ ACLEntry<CR> _ SecurityFailure<CR> _ SuperFrameSpec<CR> (2 bytes): bit 15 - Association Permitted (MSB) bit 14 - PAN Coordinator bit 13 - Reserved bit 12 - Battery Life Extension bits 8-11 - Final CAP Slot bits 4-7 - Superframe Order bits 0-3 - Beacon Order GtsPermit<CR> RSSI<CR> (RSSI is returned as - dBm) TimeStamp<CR> (3 bytes) <CR> A carriage return <CR> is sent at the end of the AS command. The Active Scan is capable of returning up to 5 PanDescriptors in a scan. The actual scan time on each channel is measured as Time = [(2 ^SD PARAM) * 15.36]	0 - 6	-

		ms. Note the total scan time is this time multiplied by the number of channels to be scanned. Also refer to SD command description.		
ED (v1.x80*)	Networking {Association}	Energy Scan. Send an Energy Detect Scan. This parameter determines the length of scan on each channel. The maximal energy on each channel is returned & each value is followed by a carriage return. An additional carriage return is sent at the end of the command. The values returned represent the detected energy level in units of -dBm. The actual scan time on each channel is measured as Time = [(2 ^ED) * 15.36] ms. Note the total scan time is this time multiplied by the number of channels to be scanned (refer to SD parameter).	0 - 6	-
EE (v1.xA0*)	Networking {Security}	AES Encryption Enable. Disable/Enable 128-bit AES encryption support. Use in conjunction with the KY command.	0 - 1	0 (disabled)
KY (v1.xA0*)	Networking {Security}	AES Encryption Key. Set the 128-bit AES (Advanced Encryption Standard) key for encrypting/decrypting data. The KY register cannot be read.	0 - (any 16-Byte value)	-

\*Firmware version in which the command was first introduced (firmware versions are numbered in hexadecimal notation.)

**Commands-RF Interfacing**

AT_ Command	Command_ Category	Name and Description	Parameter Range	Default
PL	RF Interfacing	Power Level. Select/Read the power level at which the RF module transmits conducted power.	0 - 4 0 = -10 / 10 dBm 1 = -6 / 12 dBm 2 = -4 / 14 dBm 3 = -2 / 16 dBm 4 = 0 / 18 dBm	4
CA (v1.x80*)	RF Interfacing	CCA Threshold. Set/read the CCA (Clear Channel Assessment) threshold. Prior to transmitting a packet, a CCA is performed to detect energy on the channel. If the detected energy is above the CCA Threshold, the module will not transmit the packet.	0 - 0x50 [-dBm]	0x2C (-44d dBm)

\*Firmware version in which the command was first introduced (firmware versions are numbered in hexadecimal notation.)

**Commands-Sleep (Low Power)**

AT_ Command	Command_ Category	Name and Description	Parameter Range	Default
SM	Sleep_ (Low Power)	Sleep Mode. <NonBeacon firmware> Set/Read Sleep Mode configurations.	0 - 5 0 = No Sleep 1 = Pin Hibernate 2 = Pin Doze 3 = Reserved 4 = Cyclic sleep remote 5 = Cyclic sleep remote [w/ pin wake-up 6 = [Sleep Coordinator] for backwards compatibility w/ v1.x6 only; otherwise, use CE command.	0
ST	Sleep_ (Low Power)	Time before Sleep.<NonBeacon firmware> Set/Read time period of inactivity (no serial or RF data is sent or received) before activating Sleep Mode. ST parameter is only valid with Cyclic Sleep settings (SM = 4 - 5). Coordinator and End	1 - 0xFFFF [x 1 ms]	0x1388 (5000d)

**Commands-RF Interfacing**

AT_ Command	Command_ Category	Name and Description	Parameter Range	Default
PL	RF Interfacing	Power Level. Select/Read the power level at which the RF module transmits conducted power.	0 - 4 0 = -10 / 10 dBm 1 = -6 / 12 dBm 2 = -4 / 14 dBm 3 = -2 / 16 dBm 4 = 0 / 18 dBm	4
CA (v1.x80*)	RF Interfacing	CCA Threshold. Set/read the CCA (Clear Channel Assessment) threshold. Prior to transmitting a packet, a CCA is performed to detect energy on the channel. If the detected energy is above the CCA Threshold, the module will not transmit the packet.	0 - 0x50 [-dBm]	0x2C (-44d dBm)

\*Firmware version in which the command was first introduced (firmware versions are numbered in hexadecimal notation.)

**Commands-Sleep (Low Power)**

AT_ Command	Command_ Category	Name and Description	Parameter Range	Default
SM	Sleep_ (Low Power)	Sleep Mode. <NonBeacon firmware> Set/Read Sleep Mode configurations.	0 – 5 0 = No Sleep 1 = Pin Hibernate 2 = Pin Doze 3 = Reserved 4 = Cyclic sleep remote 5 = Cyclic sleep remote w/ pin wake-up 6 = [Sleep Coordinator] for backwards compatibility w/ v1.x6 only; otherwise, use CE command.	0
ST	Sleep_ (Low Power)	Time before Sleep.<NonBeacon firmware> Set/Read time period of inactivity (no serial or RF data is sent or received) before activating Sleep Mode. ST parameter is only valid with Cyclic Sleep settings (SM = 4 - 5). Coordinator and End	1 -0xFFFF [x 1 ms]	0x1388 (5000d)

		Device ST values must be equal. Also note, the GT parameter value must always be less than the ST value. (If GT > ST, the configuration will render the module unable to enter into command mode.) If the ST parameter is modified, also modify the GT parameter accordingly.		
SP	Sleep_ (Low Power)	Cyclic Sleep Period.<NonBeacon firmware> Set/Read sleep period for cyclic sleeping remotes. Coordinator and End Device SP values should always be equal. To send Direct Messages, set SP = 0. <i>End Device</i> - SP determines the sleep period for cyclic sleeping remotes. Maximum sleep period is 268 seconds (0x68B0). <i>Coordinator</i> - If non-zero, SP determines the time to hold an indirect message before discarding it. A Coordinator will discard indirect messages after a period of (2.5 * SP).	0 - 0x68B0 [x 10 ms]	0
DP (1.x80*)	Sleep_ (Low Power)	Disassociated Cyclic Sleep Period.<NonBeacon firmware> _ <i>End Device</i> - Set/Read time period of sleep for cyclic sleeping remotes that are configured for Association but are not associated to a Coordinator. (i.e. If a device is configured to associate, configured as a Cyclic Sleep remote, but does not find a Coordinator, it will sleep for DP time before reattempting association.) Maximum sleep period is 268 seconds (0x68B0). DP should be > 0 for NonBeacon systems.	1 - 0x68B0 [x 10 ms]	0x3E8_ (1000d)

\*Firmware version in which the command was first introduced (firmware versions are numbered in hexadecimal notation.)

**Commands-Serial Interfacing**

<b>AT_ Command</b>	<b>Command_ Category</b>	<b>Name and Description</b>	<b>Parameter Range</b>	<b>Default</b>
BD	Serial_ Interfacing	Interface Data Rate. Set/Read the serial interface data rate for communications between the RF module serial port and host. Request non-standard baud rates with values above 0x80 using a terminal window. Read the BD register to find actual baud rate achieved.	0 - 7 (standard baud rates) 0 = 1200 bps 1 = 2400 2 = 4800 3 = 9600 4 = 19200 5 = 38400 6 = 57600 7 = 115200 0x80 - 0x1C200 (non-standard baud rates)	3
RO	Serial_ Interfacing	Packetization Timeout. Set/Read number of character times of inter-character delay required before transmission. Set to zero to transmit characters as they arrive instead of buffering them into one RF packet.	0 - 0xFF [x character times]	3
AP (v1.x80*)	Serial_ Interfacing	API Enable. Disable/Enable API Mode.	0 - 2 0 = Disabled 1 = API enabled 2 = API enabled (w/escaped control characters)	0
PR (v1.x80*)	Serial_ Interfacing	Pull-up Resistor Enable. Set/Read bitfield to configure internal pull-up resistor status for I/O lines Bitfield Map: bit 0 - AD4/DIO4 (pin11) bit 1 - AD3 / DIO3 (pin17) bit 2 - AD2/DIO2 (pin18) bit 3 - AD1/DIO1 (pin19) bit 4 - AD0 / DIO0 (pin20) bit 5 - RTS / AD6 / DIO6 (pin16) bit 6 - DTR / SLEEP_RQ / DI8 (pin9) bit 7 - DIN/CONFIG (pin3) Bit set to "1" specifies pull-up enabled; "0" specifies no pull-up	0 - 0xFF	0xFF

\*Firmware version in which the command was first introduced (firmware versions are numbered in hexadecimal notation.)

**Commands-I/O Settings** (sub category designated within {brackets})

<b>AT_ Command</b>	<b>Command Category</b>	<b>Name and Description</b>	<b>Parameter Range</b>	<b>Default</b>
D8	I/O Settings	DIO8 Configuration. Select/Read options for the DIO8 line (pin 9) of the RF module.	0 – 1 0 = Disabled 3 = DI (1,2,4 & 5 n/a)	0
D7 (v1.x80*)	I/O Settings	DIO7 Configuration. Select/Read settings for the DIO7 line (pin 12) of the RF module. Options include CTS flow control and I/O line settings.	0 – 1 0 = Disabled 1 = CTS Flow Control 2 = (n/a) 3 = DI 4 = DO low 5 = DO high	1
D6 (v1.x80*)	I/O Settings	DIO6 Configuration. Select/Read settings for the DIO6 line (pin 16) of the RF module. Options include RTS flow control and I/O line settings.	0 – 1 0 = Disabled 1 = RTS flow control 2 = (n/a) 3 = DI 4 = DO low 5 = DO high	0
D5 (v1.x80*)	I/O Settings	DIO5 Configuration. Configure settings for the DIO5 line (pin 15) of the RF module. Options include Associated LED indicator (blinks when associated) and I/O line settings.	0 – 1 0 = Disabled 1 = Associated indicator 2 = ADC 3 = DI 4 = DO low 5 = DO high	1
D0 - D4 (v1.xA0*)	I/O Settings	(DIO4 -DIO0) Configuration. Select/Read settings for the following lines: AD0/DIO0 (pin 20), AD1/DIO1 (pin 19), AD2/DIO2 (pin 18), AD3/DIO3 (pin 17), AD4/DIO4 (pin 11). Options include: Analog-to-digital converter, Digital Input and Digital Output.	0 – 1 0 = Disabled 1 = (n/a) 2 = ADC 3 = DI 4 = DO low 5 = DO high	0
IU (v1.xA0*)	I/O Settings	I/O Output Enable.Disables/Enables I/O data received to be sent out UART. The data is sent using an API frame regardless of the current AP parameter value.	0 – 1 0 = Disabled 1 = Enabled	1
IT (v1.xA0*)	I/O Settings	Samples before TX.Set/Read the number of samples to collect before transmitting data. Maximum number of samples is dependent upon the number of enabled inputs.	1 - 0xFF	1
IS (v1.xA0*)	I/O Settings	Force Sample.Force a read of all enabled inputs (DI or ADC). Data is returned through the UART. If no inputs are defined (DI or ADC), this command will return error.	8-bit bitmap (each bit represents the level of an I/O line setup as an output)	-

IO (v1.xA0*)	I/O Settings	Digital Output Level. Set digital output level to allow DIO lines that are setup as outputs to be changed through Command Mode.	-	-
IC (v1.xA0*)	I/O Settings	DIO Change Detect. Enables/Disables the monitoring of the change detect feature on DIO lines 0-7. If a change is detected, data is transmitted with DIO data only. Any samples queued and waiting for transmission will be sent first.	0 - 0xFF [bitfield]	0 (disabled)
IR (v1.xA0*)	I/O Settings	Sample Rate. Set/Read sample rate. When set, this parameter causes the module to sample all enabled inputs at a specified interval.	0 - 0xFFFF [x 1 msec]	0
AV (v1.xA0*)	I/O Settings	ADC Voltage Reference. Set/Read ADC reference voltage switch.	0 - 1 0 = VREF pin 1 = Internal	0
IA (v1.xA0*)	I/O Settings {I/O Line Passing}	I/O Input Address. Set/Read addresses of module to which outputs are bound. Setting all bytes to 0xFF will not allow any received I/O packet to change outputs. Setting address to 0xFFFF will allow any received I/O packet to change outputs.	0 - 0xFFFFFFFF FFFF	0xFFFFFFFF FFFFFFFF
T0 - T7 (v1.xA0*)	I/O Settings {I/O Line Passing}	(D0 - D7) Output Timeout. Set/Read Output timeout values for lines that correspond with the D0 - D7 parameters. When output is set (due to I/O line passing) to a non-default level, a timer is started which when expired will set the output to its default level. The timer is reset when a valid I/O packet is received.	0 - 0xFF [x 100 ms]	0xFF
P0	I/O Settings {I/O Line Passing}	PWM0 Configuration. Select/Read function for PWM0 pin.	0 - 2 0 = Disabled 1 = RSSI 2 = PWM Output	1
P1 (v1.xA0*)	I/O Settings {I/O Line Passing}	PWM1 Configuration. Select/Read function for PWM1 pin.	0 - 2 0 = Disabled 1 = RSSI 2 = PWM Output	0
M0 (v1.xA0*)	I/O Settings {I/O Line Passing}	PWM0 Output Level. Set/Read the PWM0 output level.	0 - 0x03FF	-
M1 (v1.xA0*)	I/O Settings {I/O Line Passing}	PWM1 Output Level. Set/Read the PWM0 output level.	0 - 0x03FF	-
PT (v1.xA0*)	I/O Settings {I/O Line Passing}	PWM Output Timeout. Set/Read output timeout value for both PWM outputs. When PWM is set to a non-zero value: Due to I/O line passing, a time is started	0 - 0xFF [x 100 ms]	0xFF

		which when expired will set the PWM output to zero. The timer is reset when a valid I/O packet is received.]		
RP	I/O Settings {I/O Line Passing}	RSSI PWM Timer.Set/Read PWM timer register. Set the duration of PWM (pulse width modulation) signal output on the RSSI pin. The signal duty cycle is updated with each received packet and is shut off when the timer expires.]	0 - 0xFF [x 100 ms]	0x28 (40d)

\*Firmware version in which the command was first introduced (firmware versions are numbered in hexadecimal notation.)

**Commands-Diagnostics**

<b>AT_ Command</b>	<b>Command Category</b>	<b>Name and Description</b>	<b>Parameter Range</b>	<b>Default</b>
VR	Diagnostics	Firmware Version. Read firmware version of the RF module.	0 - 0xFFFF [read-only]	Factory-set
VL (v1.x80*)	Diagnostics	Firmware Version - Verbose. Read detailed version information (including application build date, MAC, PHY and bootloader versions).	-	-
HV (v1.x80*)	Diagnostics	Hardware Version. Read hardware version of the RF module.	0 - 0xFFFF [read-only]	Factory-set
DB	Diagnostics	Received Signal Strength. Read signal level [in dB] of last good packet received (RSSI). Absolute value is reported. (For example: 0x58 = -88 dBm) Reported value is accurate between -40 dBm and RX sensitivity.	0 - 0x64 [read-only]	-
EC (v1.x80*)	Diagnostics	CCA Failures.Reset/Read count of CCA (Clear Channel Assessment) failures. This parameter value increments when the module does not transmit a packet because it detected energy above the CCA threshold level set with CA command. This count saturates at its maximum value. Set count to "0" to reset count.	0 - 0xFFFF	-
EA (v1.x80*)	Diagnostics	ACK Failures. Reset/Read count of acknowledgment failures. This parameter value increments when the module expires its transmission retries without receiving an ACK on a packet transmission. This count saturates at its maximum value. Set the parameter to "0" to reset count.	0 - 0xFFFF	-

ED (v1.x80*)	Diagnostics	Energy Scan. Send 'Energy Detect Scan'. ED parameter determines the length of scan on each channel. The maximal energy on each channel is returned and each value is followed by a carriage return. Values returned represent detected energy levels in units of -dBm. Actual scan time on each channel is measured as Time = [(2 ^ SD) * 15.36] ms. Total scan time is this time multiplied by the number of channels to be scanned.	0 - 6	-
--------------	-------------	---	-------	---

\*Firmware version in which the command was first introduced (firmware versions are numbered in hexadecimal notation.)

**Commands-AT Command Options**

AT Command	Command Category	Name and Description	Parameter Range	Default
CT	AT Command Mode Options	Command Mode Timeout. Set/Read the period of inactivity (no valid commands received) after which the RF module automatically exits AT Command Mode and returns to Idle Mode.	2 - 0xFFFF [x 100 ms]	0x64 (100d)
CN	AT Command Mode Options	Exit Command Mode. Explicitly exit the module from AT Command Mode.	--	--
AC (v1.xA0*)	AT Command Mode Options	Apply Changes. Explicitly apply changes to queued parameter value(s) and re-initialize module.	--	--
GT	AT Command Mode Options	Guard Times. Set required period of silence before and after the Command Sequence Characters of the AT Command Mode Sequence (GT+ CC + GT). The period of silence is used to prevent inadvertent entrance into AT Command Mode.	2 - 0x0CE4 [x 1 ms]	0x3E8 (1000d)
CC	AT Command Mode Options	Command Sequence Character. Set/Read the ASCII character value to be used between Guard Times of the AT Command Mode Sequence (GT+CC+GT). The AT Command Mode Sequence enters the RF module into AT Command Mode.	0 - 0xFF	0x2B ( '+' ASCII)

\*Firmware version in which the command was first introduced (firmware versions are numbered in hexadecimal notation.)

## Command Descriptions

Command descriptions in this section are listed alphabetically. Command categories are designated within "< >" symbols that follow each command title. Zlinx Radio Modems expect parameter values in hexadecimal (designated by the "0x" prefix). All modules operating within the same network should contain the same firmware version.

### **A1 (End Device Association) Command**

<Networking {Association}> The A1 command is used to set and read association options for an End Device.

Use the table below to determine End Device behavior in relation to the A1 parameter.

AT Command: ATA1

Parameter Range: 0 - 0x0F [bitfield]

Default Parameter Value: 0

Related Commands: ID (PAN ID), NI (Node Identifier), CH (Channel), CE (Coordinator Enable), A2 (Coordinator Association)

Minimum Firmware Version Required: v1.x80

Bit number	End Device Association Option
0 - ReassignPanID	0 - Will only associate with Coordinator operating on PAN ID that matches Node Identifier
	1 - May associate with Coordinator operating on any PAN ID
1 - ReassignChannel	0 - Will only associate with Coordinator operating on Channel that matches CH setting
	1 - May associate with Coordinator operating on any Channel
2 - AutoAssociate	0 - Device will not attempt Association
	1 - Device attempts Association until success_ Note: This bit is used only for Non-Beacon systems. End Devices in a Beaconsing system must always associate to a Coordinator
3 - PollCoordOnPinWake	0 - Pin Wake will not poll the Coordinator for pending (indirect) Data
	1 - Pin Wake will send Poll Request to Coordinator to extract any pending data
4 - 7	[reserved]

**A2 (Coordinator Association Command)**

<Networking {Association}> The A2 command is used to set and read association options of the Coordinator.

Use the table below to determine Coordinator behavior in relation to the A2 parameter.

AT Command: ATA2  
 Parameter Range: 0 - 7 [bitfield]  
 Default Parameter Value: 0  
 Related Commands: ID (PAN ID), NI (Node Identifier), CH (Channel), CE (Coordinator Enable), A1 (End Device Association), AS Active Scan, ED (Energy Scan)  
 Minimum Firmware Version Required: v1.x80

Bit number	End Device Association Option
0 - ReassignPanID	0 - Coordinator will not perform Active Scan to locate available PAN ID. It will operate on ID (PAN ID).
	1 - Coordinator will perform Active Scan to determine an available ID (PAN ID). If a PAN ID conflict is found, the ID parameter will change.
1 - ReassignChannel	0 - Coordinator will not perform Energy Scan to determine free channel. It will operate on the channel determined by the CH parameter.
	1 - Coordinator will perform Energy Scan to find a free channel, then operate on that channel.
2 - AllowAssociate	0 - Coordinator will not allow any devices to associate to it.
	1 - Coordinator will allow devices to associate to it.
3 - 7	[reserved]

**AC (Apply Changes) Command**

<AT Command Mode Options> The AC command is used to explicitly apply changes to module parameter values.

'Applying changes' means that the module is re-initialized based on changes made to its parameter values. Once changes are applied, the module immediately operates according to the new parameter values.

AT Command: ATAC  
 Minimum Firmware Version Required: v1.xA0

This behavior is in contrast to issuing the WR (Write) command. The WR command saves parameter values to non-volatile memory, but the module still operates according to previously saved values until the module is re-booted or the CN (Exit AT Command Mode) command is issued.

Refer to the "AT Command - Queue Parameter Value" API type for more information.

**AI (Association Indication) Command**

<Networking {Association}> The AI command is used to indicate occurrences of errors during the last association request.

Use the table below to determine meaning of the returned values.

AT Command: ATAI

Parameter Range: 0 - 0x13

[read-only]

Related Commands: AS (Active Scan), ID (PAN ID), CH (Channel), ED (Energy Scan), A1 (End

Device Association), A2 (Coordinator Association), CE (Coordinator Enable)

Minimum Firmware Version Required:

v1.x80

Returned Value (Hex)	Association Indication
0x00	Successful Completion - Coordinator successfully started or End Device association complete
0x01	Active Scan Timeout
0x02	Active Scan found no PANs
0x03	Active Scan found PAN, but the Coordinator Allow Association bit is not set
0x04	Active Scan found PAN, but Coordinator and End Device are not configured to support beacons
0x05	Active Scan found PAN, but Coordinator ID (PAN ID) value does not match the ID of the End Device
0x06	Active Scan found PAN, but Coordinator CH (Channel) value does not match the CH of the End Device
0x07	Energy Scan Timeout
0x08	Coordinator start request failed
0x09	Coordinator could not start due to Invalid Parameter
0x0A	Coordinator Realignment is in progress
0x0B	Association Request not sent
0x0C	Association Request timed out - no reply was received
0x0D	Association Request had an Invalid Parameter
0x0E	Association Request Channel Access Failure - Request was not transmitted - CCA failure
0x0F	Remote Coordinator did not send an ACK after Association Request was sent
0x10	Remote Coordinator did not reply to the Association Request, but an ACK was received _ after sending the request
0x11	[reserved]
0x12	Sync-Loss - Lost synchronization with a Beaconing Coordinator
0x13	Disassociated - No longer associated to Coordinator

**AP (API Enable) Command**

<Serial Interfacing> The AP command is used to enable the RF module to operate using a framebased API instead of using the default Transparent (UART) mode.

AT Command: ATAP

Parameter Range:0 - 2

Parameter	Configuration
0	Disabled (Transparent operation)
1	API enabled
2	API enabled (with escaped characters)

Default Parameter Value:0

Minimum Firmware Version Required: v1.x80

Refer to the API Operation section when API operation is enabled (AP = 1 or 2).

**AS (Active Scan) Command**

<AT Command Mode Options> The AS command is used to send a Beacon Request to a Broadcast Address (0xFFFF) and Broadcast PAN (0xFFFF) on every channel. The parameter determines the amount of time the RF module will listen for Beacons on each channel. A 'PanDescriptor' is created and returned for every Beacon received from the scan. Each PanDescriptor contains the following information:

AT Command: ATAS

Parameter Range: 0 - 6

Related Command: SD (Scan Duration), DL (Destination Low Address), DH (Destination High Address), ID (PAN ID), CH (Channel)

Minimum Firmware Version Required: v1.x80

CoordAddress (SH + SL parameters)<CR>

CoordPanID (ID parameter)<CR>

CoordAddrMode <CR>

0x02 = 16-bit Short Address

0x03 = 64-bit Long Address

Channel (CH parameter) <CR>

SecurityUse<CR>

ACLEntry<CR>

SecurityFailure<CR>

SuperFrameSpec<CR> (2 bytes):

bit 15 - Association Permitted (MSB)

bit 14 - PAN Coordinator

bit 13 - Reserved

bit 12 - Battery Life Extension

bits 8-11 - Final CAP Slot

bits 4-7 - Superframe Order

bits 0-3 - Beacon Order

GtsPermit<CR>

RSSI<CR> (- RSSI is returned as -dBm)

TimeStamp<CR> (3 bytes)

<CR> (A carriage return <CR> is sent at the end of the AS command.

The Active Scan is capable of returning up to 5 PanDescriptors in a scan. The actual scan time on each channel is measured as  $Time = [(2 \wedge (SD \text{ Parameter})) * 15.36] \text{ ms}$ . Total scan time is this time multiplied by the number of channels to be scanned.

NOTE: Refer the scan table in the SD description to determine scan times. If using API Mode, no <CR>'s are returned in the response. Refer to the API Mode Operation section.

**AV (ADC Voltage Reference) Command**

<Serial Interfacing> The AV command is used to set/read the ADC reference voltage switch.

AT Command: ATAV

Parameter Range:0 - 1

Parameter	Configuration
0	VREF Pin
1	Internal (on-board reference - VCC)

**BD (Interface Data Rate) Command**

<Serial Interfacing> The BD command is used to set and read the serial interface data rate used between the RF module and host. This parameter determines the rate at which serial data is sent to the module from the host. Modified interface data rates do not take effect until the CN (Exit AT Command Mode) command is issued and the system returns the 'OK' response.

Default Parameter Value:0  
 Parameter Range:0-7 (standard rates)  
 Required:0x0-0x1C200 (non-standard rates)

Parameter	Configuration (bps)
0	1200
1	2400
2	4800
3	9600
4	19200
5	38400
6	57600
7	115200

When parameters 0-7 are sent to the module, the respective interface data rates are used (as shown in the table on the right).

The RF data rate is not affected by the BD parameter. If the interface data rate is set higher than the RF data rate, a flow control configuration may need to be implemented.

Default Parameter Value:3

**Non-standard Interface Data Rates:**

Any value above 0x07 will be interpreted as an actual baud rate. When a value above 0x07 is sent, the closest interface data rate represented by the number is stored in the BD register. For example, a rate of 19200 bps can be set by sending the following command line "ATBD4B00".

When the BD command is sent with a non-standard interface data rate, the UART will adjust to accommodate the requested interface rate. In most cases, the clock resolution will cause the stored BD parameter to vary from the parameter that was sent (refer to the table below). Reading the BD command (send "ATBD" command without an associated parameter value) will return the value actually stored in the module's BD register.

**Parameters Sent Versus Parameters Stored**

BD Parameter Sent (HEX)	Interface Data Rate (bps)	BD Parameter Stored (HEX)
0	1200	0

4	19,200	4
7	115,200	7
12C	300	12B
1C200	115,200	1B207

**CA (CCA Threshold) Command**

<RF Interfacing> CA command is used to set and read CCA (Clear Channel Assessment) thresholds.

Prior to transmitting a packet, a CCA is performed to detect energy on the transmit channel. If the detected energy is above the CCA Threshold, the RF module will not transmit the packet.

AT Command: ATCA

Parameter Range: 0 - 0x50 [-dBm]

Default Parameter Value: 0x2C  
□(-44 decimal dBm)

Minimum Firmware Version Required: v1.x80

**CC (Command Sequence Character) Command**

<AT Command Mode Options> The CC command is used to set and read the ASCII character used between guard times of the AT Command Mode Sequence (GT + CC + GT). This sequence enters the RF module into AT Command Mode so that data entering the module from the host is recognized as commands instead of payload.

AT Command: ATCC

Parameter Range: 0 - 0xFF

Default Parameter Value: 0x2B (ASCII "+")

Related Command: GT (Guard Times)

The AT Command Sequence is explained further in the AT Command Mode section.

**CE (Coordinator Enable) Command**

<Serial Interfacing> The CE command is used to set and read the behavior (End Device vs. Coordinator) of the RF module.

AT Command: ATCE

Parameter Range:0 - 1

Parameter	Configuration
0	End Device
1	Coordinator

Default Parameter Value:0

Minimum Firmware Version Required: v1.x80

**CH (Channel) Command**

<Networking {Addressing}> The CH command is used to set/read the operating channel on which RF connections are made between RF modules. The channel is one of three addressing options available to the module. The other options are the PAN ID (ID command) and destination addresses (DL & DH commands).

---

AT Command: ATCH

---

Parameter Range: 0x0B - 0x1A

---

Default Parameter Value: 0x0C  
(12 decimal)

---

Related Commands: ID (PAN ID), DL (Destination Address Low, DH (Destination Address High)

---

In order for modules to communicate with each other, the modules must share the same channel number. Different channels can be used to prevent modules in one network from listening to transmissions of another. Adjacent channel rejection is 23 dB.

The module uses channel numbers of the 802.15.4 standard.

$$\text{Center Frequency} = 2.405 + (\text{CH} - 11d) * 5 \text{ MHz} \quad (d = \text{decimal})$$

**CN (Exit Command Mode) Command**

<AT Command Mode Options> The CN command is used to explicitly exit the RF module from AT Command Mode.

---

AT Command: ATCN

---

**CT (Command Mode Timeout) Command**

<AT Command Mode Options> The CT command is used to set and read the amount of inactive time that elapses before the RF module automatically exits from AT Command Mode and returns to Idle Mode.

---

AT Command: ATCT

---

Parameter Range: 2 - 0xFFFF [x 100 milliseconds]

---

Default Parameter Value: 0x64 (100 decimal (which equals 10 decimal seconds))

---

Number of bytes returned: 2

---

Related Command: CN (Exit Command Mode)

---

Use the CN (Exit Command Mode) command to exit AT Command Mode manually.

**D0 - D4 (DIO Configuration) Commands**

<I/O Settings> The D0, D1, D2, D3 and D4 commands are used to select/read the behavior of their respective AD/DIO lines (pins 20, 19, 18, 17 and 11 respectively).

Options include:

- Analog-to-digital converter
- Digital input
- Digital output

AT Commands: \_ATD0, ATD1, ATD2, ATD3, ATD4

Parameter Range:0 - 5

Parameter	Configuration
0	Disabled
1	n/a
2	ADC
3	DI
4	DO low
5	DO high

Default Parameter Value:0

Minimum Firmware Version Required: 1.x.A0

**D5 (DIO5 Configuration) Command**

<I/O Settings> The D5 command is used to select/read the behavior of the DIO5 line (pin 15).

Options include:

- Associated Indicator (LED blinks when the module is associated)
- Analog-to-digital converter
- Digital input
- Digital output

AT Command: ATD5

Parameter Range:0 - 5

Parameter	Configuration
0	Disabled
1	Associated Indicator
2	ADC
3	DI
4	DO low
5	DO high

Default Parameter Value:1

Parameters 2-5 supported as of firmware version 1.xA0

**D6 (DIO6 Configuration)**

**Command**

</I/O Settings> The D6 command is used to select/read the behavior of the DIO6 line (pin 16).

Options include:

- RTS flow control
- Analog-to-digital converter
- Digital input
- Digital output

AT Command: ATD6

Parameter Range:0 - 5

Parameter	Configuration
0	Disabled
1	RTS Flow Control
2	n/a
3	DI
4	DO low
5	DO high

Default Parameter Value:0

Parameters 3-5 supported as of firmware version 1.xA0

**D7 (DIO7 Configuration)**

**Command**

</I/O Settings> The D7 command is used to select/read the behavior of the DIO7 line (pin 12).

Options include:

- CTS flow control
- Analog-to-digital converter
- Digital input
- Digital output

AT Command: ATD7

Parameter Range:0 - 5

Parameter	Configuration
0	Disabled
1	CTS Flow Control
2	n/a
3	DI
4	DO low
5	DO high

Default Parameter Value:1

Parameters 3-5 supported as of firmware version 1.x.A0

**D8 (DI8 Configuration)**

**Command**

</I/O Settings> The D8 command is used to select/read the behavior of the DI8 line (pin 9).

This command enables configuring the pin to function as a digital input. This line is also used with Pin Sleep.

AT Command: ATD8

Parameter Range:0 - 5 \_ (1, 2, 4 & 5 n/a)

Parameter	Configuration
0	Disabled
3	DI

Default Parameter Value:0

Minimum Firmware Version Required: 1.xA0

**DA (Force Disassociation)**

**Command**

<(Special)> The DA command is used to immediately disassociate an End Device from a Coordinator and reattempt to associate.

AT Command: ATDA

Minimum Firmware Version Required: v1.x80

**DB (Received Signal Strength)**

**Command**

<Diagnostics> DB parameter is used to read the received signal strength (in dBm) of the last RF packet received. Reported values are accurate between -40 dBm and the RF module's receiver sensitivity.

AT Command: ATDB

Parameter Range: 0 - 0x64 [read-only]

Absolute values are reported. For example: 0x58 = -88 dBm (decimal). If no packets have been received (since last reset, power cycle or sleep event), "0" will be reported.

**DH (Destination Address High)**

**Command**

<Networking {Addressing}> The DH command is used to set and read the upper 32 bits of the RF module's 64-bit destination address. When combined with the DL (Destination Address Low) parameter, it defines the destination address used for transmission.

AT Command: ATDH

Parameter Range: 0 - 0xFFFFFFFF

Default Parameter Value: 0

Related Commands: DL (Destination Address Low), CH (Channel), ID (PAN VID), MY (Source Address)

An module will only communicate with other modules having the same channel (CH parameter), PAN ID (ID parameter) and destination address (DH + DL parameters).

To transmit using a 16-bit address, set the DH parameter to zero and the DL parameter less than 0xFFFF. 0x00000000000000FFFF (DL concatenated to DH) is the broadcast address for the PAN.

**DL (Destination Address Low)**

**Command**

<Networking {Addressing}> The DL command is used to set and read the lower 32 bits of the RF module's 64-bit destination address. When combined with the DH (Destination Address High) parameter, it defines the destination address used for transmission.

AT Command: ATDL

Parameter Range: 0 - 0xFFFFFFFF

Default Parameter Value: 0

Related Commands: DH (Destination Address High), CH (Channel), ID (PAN VID), MY (Source Address)

A module will only communicate with other modules having the same channel (CH parameter), PAN ID (ID parameter) and destination address (DH + DL parameters).

To transmit using a 16-bit address, set the DH parameter to zero and the DL parameter less than 0xFFFF. 0x00000000000000FFFF (DL concatenated to DH) is the broadcast address for the PAN.

**DN (Destination Node) Command)**

<Networking {Identification}> The DN command is used to resolve a NI (Node Identifier) string to a physical address. The following events occur upon successful command execution:

AT Command: ATDN
Parameter Range: 20-character ASCII String
Minimum Firmware Version Required: v1.x80

1. DL and DH are set to the address of the module with the matching NI (Node Identifier).
2. 'OK' is returned.
3. RF module automatically exits AT Command Mode.

If there is no response from a modem within 200 msec or a parameter is not specified (left blank), the command is terminated and an 'ERROR' message is returned.

**DP (Disassociation Cyclic Sleep Period) Command**

<Sleep Mode (Low Power)>

**NonBeacon Firmware**

*End Device* - The DP command is used to set and read the time period of sleep for cyclic sleeping remotes that are configured for Association but are not associated to a Coordinator. (i.e. If a device is configured to associate, configured as a Cyclic Sleep remote, but does not find a Coordinator; it will sleep for DP time before reattempting association.) Maximum sleep period is 268 seconds (0x68B0). DP should be > 0 for NonBeacon systems.

AT Command: ATDP
Parameter Range: 1 - 0x68B0_ [x 10 milliseconds]
Default Parameter Value:0x3E8_ (1000 decimal)
Related Commands: SM (Sleep Mode), SP (Cyclic Sleep Period), ST (Time before Sleep)
Minimum Firmware Version Required: v1.x80

**EA (ACK Failures) Command**

<Diagnostics> The EA command is used to reset and read the count of ACK (acknowledgement) failures. This parameter value increments when the module expires its transmission retries without receiving an ACK on a packet transmission. This count saturates at its maximum value.

AT Command: ATEA
Parameter Range:0 - 0xFFFF
Minimum Firmware Version Required: v1.x80

Set the parameter to "0" to reset count.

**EC (CCA Failures) Command**

<Diagnostics> The EC command is used to read and reset the count of CCA (Clear Channel Assessment) failures. This parameter value increments when the RF module does not transmit a packet due to the detection of energy that is above the CCA threshold level (set with CA command). This count saturates at its maximum value.

AT Command: ATEC
Parameter Range:0 - 0xFFFF
Related Command: CA (CCA Threshold)
Minimum Firmware Version Required: v1.x80

Set the EC parameter to "0" to reset count.

**ED (Energy Scan) Command**

<Networking {Association}> The ED command is used to send an "Energy Detect Scan". This parameter determines the length of scan on each channel. The maximal energy on each channel is returned and each value is followed by a carriage return. An additional carriage return is sent at the end of the command.

AT Command: ATED

Parameter Range:0 - 6

Related Command: SD (Scan Duration), SC (Scan Channel)

Minimum Firmware Version Required: v1.x80

The values returned represent the detected energy level in units of -dBm. The actual scan time on each channel is measured as  $Time = [(2 \wedge ED \text{ PARAM}) * 15.36] \text{ ms}$ .

Note: Total scan time is this time multiplied by the number of channels to be scanned. Also refer to the SD (Scan Duration) table. Use the SC (Scan Channel) command to choose which channels to scan.

**EE (AES Encryption Enable) Command**

<Networking {Security}> The EE command is used to set/read the parameter that disables/enables 128-bit AES encryption.

AT Command: ATEE

Parameter Range:0 - 1

Parameter	Configuration
0	Disabled
1	Enabled

Default Parameter Value:0

Related Commands: KY (Encryption Key), AP (API Enable), MM (MAC Mode)

Minimum Firmware Version Required: v1.xA0

The Zlinx firmware uses the 802.15.4 Default Security protocol and uses AES encryption with a 128-bit key. AES encryption dictates that all modules in the network use the same key and the maximum RF packet size is 95 Bytes.

When encryption is enabled, the module will always use its 64-bit long address as the source address for RF packets. This does not affect how the MY (Source Address), DH (Destination Address High) and DL (Destination Address Low) parameters work

If MM (MAC Mode) > 0 and AP (API Enable) parameter > 0:

With encryption enabled and a 16-bit short address set, receiving modules will only be able to issue RX (Receive) 64-bit indicators. This is not an issue when MM = 0.

If a module with a non-matching key detects RF data, but has an incorrect key: When encryption is enabled, non-encrypted RF packets received will be rejected and will not be sent out the UART.

Transparent Operation --> All RF packets are sent encrypted if the key is set.

API Operation --> Receive frames use an option bit to indicate that the packet was encrypted.

**FP (Force Poll) Command**

<Networking (Association)> The FP command is used to request indirect messages being held by a Coordinator.

AT Command: ATFP

Minimum Firmware Version Required: v1.x80

**FR (Software Reset) Command**

<Special> The FR command is used to force a software reset on the RF module. The reset simulates powering off and then on again the module.

AT Command: ATFR

Minimum Firmware Version Required: v1.x80

**GT (Guard Times) Command**

<AT Command Mode Options> GT Command is used to set the DI (data in from host) time-of-silence that surrounds the AT command sequence character (CC Command) of the AT Command Mode sequence (GT + CC + GT).

The DI time-of-silence is used to prevent inadvertent entrance into AT Command Mode.

AT Command: ATGT

Parameter Range: 2 - 0x0CE4 [x 1 millisecond]

Default Parameter Value: 0x3E8 \_ (1000 decimal)

Related Command: CC (Command Sequence Character)

Refer to the Command Mode section for more information regarding the AT Command Mode Sequence.

**HV (Hardware Version) Command**

<Diagnostics> The HV command is used to read the hardware version of the RF module.

AT Command: ATHV

Parameter Range: 0 - 0xFFFF [Read-only]

Minimum Firmware Version Required: v1.x80

**IA (I/O Input Address) Command**

<I/O Settings {I/O Line Passing}> The IA command is used to bind a module output to a specific address. Outputs will only change if received from this address. The IA command can be used to set/read both 16 and 64-bit addresses.

AT Command: ATIA

Parameter Range: 0 - 0xFFFFFFFFFFFFFFFF

Default Parameter Value: 0xFFFFFFFFFFFFFFFF\_ (will not allow any received I/O packet to change outputs)

Minimum Firmware Version Required: v1.xA0

Setting all bytes to 0xFF will not allow the reception of any I/O packet to change outputs. Setting the IA address to 0xFFFF will cause the module to accept all I/O packets.

**IC (DIO Change Detect) Command**

<I/O Settings> The IC command is used to enable the monitoring of the change detect feature on DIO lines 0-7. If a change is detected, data is transmitted with DIO data only. Any samples queued and waiting for transmission are sent first.

AT Command: ATIC
Parameter Range: 0 - 0xFF [bitfield]
Default Parameter Value: 0 (disabled)
Minimum Firmware Version Required: 1.xA0

Refer to the "ADC and Digital I/O Line Support" sections of the "RF Module Operations" chapter for more information.

**ID (Pan ID) Command**

<Networking {Addressing}> The ID command is used to set and read the PAN (Personal Area Network) ID of the RF module. Only modules with matching PAN IDs can communicate with each other. Unique PAN IDs enable control of which RF packets are received by a module.

AT Command: ATID
Parameter Range: 0 - 0xFFFF
Default Parameter Value: 0x3332 (13106 decimal)

Setting the ID parameter to 0xFFFF indicates a global transmission for all PANs. It does not indicate a global receive.

**IO (Digital Output Level) Command**

<I/O Settings> The IO command is used to set digital output levels. This allows DIO lines setup as outputs to be changed through Command Mode.

AT Command: ATIO
Parameter Range: 8-bit bitmap _ (where each bit represents the level of an I/O line that is setup as an output.)
Minimum Firmware Version Required: v1.xA0

**IR (Sample Rate) Command**

<I/O Settings> The IR command is used to set/read the sample rate. When set, the module will sample all enabled DIO/ADC lines at a specified interval. This command allows periodic reads of the ADC and DIO lines in a non-Sleep Mode setup.

AT Command: ATIR
Parameter Range: 0 - 0xFFFF [x 1 msec]_ (cannot guarantee 1 ms timing when IT=1)
Default Parameter Value: 0
Related Command: IT (Samples before TX)
Minimum Firmware Version Required: v1.xA0

Example: When IR = 0x0A, the sample rate is 10 ms (or 100 Hz).

**IS (Force Sample) Command**

<I/O Settings> The IS command is used to force a read of all enabled DIO/ADC lines. The data is returned through the UART. When operating in Transparent Mode (AP=0), the data is returned in the following format:

AT Command: ATIS
Parameter Range: 1 - 0xFF
Default Parameter Value: 1
Minimum Firmware Version Required: v1.xA0

All bytes are converted to ASCII:  
 number of samples<CR>  
 channel mask<CR>  
 DIO data<CR> (If DIO lines are enabled<CR>  
 ADC channel Data<cr> <-This will repeat for every enabled ADC channel<CR>  
 <CR> (end of data noted by extra <CR>)

When operating in API mode (AP > 0), the command will immediately return an 'OK' response. The data will follow in the normal API format for DIO data.

**IT (Samples before TX)**

**Command**

<I/O Settings> The IT command is used to set/read the number of DIO and ADC samples to collect before transmitting data.

AT Command: ATIT

Parameter Range: 1 - 0xFF

Default Parameter Value:1

Minimum Firmware Version Required: v1.xA0

One ADC sample is considered complete when all enabled ADC channels have been read. The module can buffer up to 93 Bytes of sample data. Since the module uses a 10-bit A/D converter, each sample uses two Bytes. This leads to a maximum buffer size of 46 samples or IT=0x2E.

When Sleep Modes are enabled and IR (Sample Rate) is set, the module will remain awake until IT samples have been collected.

**IU (I/O Output Enable) Command**

<I/O Settings> The IU command is used to disable/enable I/O UART output. When enabled (IU = 1), received I/O line data packets are sent out the UART. The data is sent using an API frame regardless of the current AP parameter value.

AT Command: ATIU

Parameter Range:0 - 1

Parameter	Configuration
0	Disabled -Received I/O line data packets will NOT sent out UART.
1	Enabled -Received I/O line data will be sent out UART

Default Parameter Value:1

Minimum Firmware Version Required: 1.xA0

**KY (AES Encryption Key)**

**Command**

<Networking {Security}> The KY command is used to set the 128-bit AES (Advanced Encryption Standard) key for encrypting/decrypting data. Once set, the key cannot be read out of the module by any means.

AT Command: ATKY

Parameter Range:0 - (any 16-Byte value)

Default Parameter Value:0

Related Command: EE (Encryption Enable)

Minimum Firmware Version Required: v1.xA0

The entire payload of the packet is encrypted using the key and the CRC is computed across the ciphertext. When encryption is enabled, each packet carries an additional

16 Bytes to convey the random CBC Initialization Vector (IV) to the receiver(s). The KY value may be "0" or any 128-bit value. Any other value, including entering ATKY by itself with no parameters, will cause an error. A module with the wrong key (or no key) will receive encrypted data, but the data driven out the serial port will be meaningless. Likewise, a module with a key will receive unencrypted data sent from a module without a key, but the output will be meaningless. Because CBC mode is utilized, repetitive data appears differently in different transmissions due to the randomly-generated IV.

When queried, the system will return an 'OK' message and the value of the key will not be returned.

**M0 (PWM0 Output Level)**

**Command**

<I/O Settings> The M0 command is used to set/read the output level of the PWM0 line (pin 6).

Before setting the line as an output:

1. Enable PWM0 output (P0 = 2)
2. Apply settings (use CN or AC)

AT Command: ATM0

Parameter Range:0 - 0x03FF [steps]

Default Parameter Value:0

Related Commands: P0 (PWM0 Enable), AC (Apply Changes), CN (Exit Command Mode)

Minimum Firmware Version Required: v1.xA0

The PWM period is 64 μsec and there are 0x03FF (1023 decimal) steps within this period. When M0 = 0 (0% PWM), 0x01FF (50% PWM), 0x03FF (100% PWM), etc.

**M1 (PWM1 Output Level)**

**Command**

<I/O Settings> The M1 command is used to set/read the output level of the PWM1 line (pin 7).

Before setting the line as an output:

1. Enable PWM1 output (P1 = 2)
2. Apply settings (use CN or AC)

AT Command: ATM1

Parameter Range:0 - 0x03FF

Default Parameter Value:0

Related Commands: P1 (PWM1 Enable), AC (Apply Changes), CN (Exit Command Mode)

Minimum Firmware Version Required: v1.xA0

**MM (MAC Mode) Command**

<Networking {Addressing}> The MM command is used to set and read the MAC Mode value. The MM command disables/enables the use of a Max-Stream header contained in the 802.15.4 RF packet. By default (MM = 0), B&B Mode is enabled and the module adds an extra header to the data portion of the 802.15.4 packet. This enables the following features:

- ND and DN command support
- Duplicate packet detection when using ACKs

The MM command allows users to turn off the use of the extra header. Modes 1 and 2 are strict 802.15.4 modes. If the B&B header is disabled, ND and DN parameters are also disabled.

AT Command: ATMM

Parameter Range: 0 - 2

Parameter	Configuration
0	B&B Mode (802.15.4 + B&B header)
1	802.15.4 (no ACKs)
2	802.15.4 (with ACKs)

Default Parameter Value: 0

Related Commands: ND (Node Discover), DN (Destination Node)

Minimum Firmware Version Required: v1.x80

Note: When MM > 0, application and CCA failure retries are not supported.

**MY (16-bit Source Address) Command**

<Networking {Addressing}> The MY command is used to set and read the 16-bit source address of the RF module.

By setting MY to 0xFFFF, the reception of RF packets having a 16-bit address is disabled. The 64-bit address is the module's serial number and is always enabled.

AT Command: ATMY

Parameter Range: 0 - 0xFFFF

Default Parameter Value: 0

Related Commands: DH (Destination Address High), DL (Destination Address Low), CH (Channel), ID (PAN ID)

**ND (Node Discover) Command**

<Networking {Identification}> The ND command is used to discover and report all modules on its current operating channel (CH parameter) and PAN ID (ID parameter). ND also accepts an NI (Node Identifier) value as a parameter. In this case, only a module matching the supplied identifier will respond.

AT Command: ATND

Range: optional 20-character NI value

Related Commands: CH (Channel), ID (Pan ID), MY (Source Address), SH (Serial Number High), SL (Serial Number Low), NI (Node Identifier), NT (Node Discover Time)

Minimum Firmware Version Required: v1.x80

ND uses a 64-bit long address when sending and responding to an ND request. The ND command causes a module to transmit a globally addressed ND command packet. The amount of time allowed for responses is determined by the NT (Node Discover Time) parameter.

In AT Command mode, command completion is designated by a carriage return (0x0D). Since two carriage returns end a command response, the application will

receive three carriage returns at the end of the command. If no responses are received, the application should only receive one carriage return. When in API mode, the application should receive a frame (with no data) and status (set to 'OK') at the end of the command. When the ND command packet is received, the remote sets up a random time delay (up to 2.2 sec) before replying as follows:

Node Discover Response (AT command mode format - Transparent operation):

MY (Source Address) value<CR>  
 SH (Serial Number High) value<CR>  
 SL (Serial Number Low) value<CR>  
 DB (Received Signal Strength) value<CR>  
 NI (Node Identifier) value<CR>  
 <CR> (This is part of the response and not the end of command indicator.)

Node Discover Response (API format - data is binary (except for NI)):

2 bytes for MY (Source Address) value  
 4 bytes for SH (Serial Number High) value  
 4 bytes for SL (Serial Number Low) value  
 1 byte for DB (Received Signal Strength) value  
 NULL-terminated string for NI (Node Identifier) value (max 20 bytes w/out NULL terminator)

**NI (Node Identifier) Command**

<Networking {Identification}> The NI command is used to set and read a string for identifying a particular node.

AT Command: ATNI

Parameter Range: 20-character ASCII string

Related Commands: ND (Node Discover), DN (Destination Node)

Minimum Firmware Version Required: v1.x80

**Rules:**

- Register only accepts printable ASCII data.
- A string can not start with a space.
- A carriage return ends command
- Command will automatically end when maximum bytes for the string have been entered.

This string is returned as part of the ND (Node Discover) command. This identifier is also used with the DN (Destination Node) command.

**NT (Node Discover Time) Command**

<Networking {Identification}> The NT command is used to set the amount of time a base node will wait for responses from other nodes when using the ND (Node Discover) command. The NT value is transmitted with the ND command.

AT Command: ATNT

Parameter Range: 0x01 - 0xFC  
 [x 100 msec]

Default: 0x19 (2.5 decimal seconds)

Related Commands: ND (Node Discover)

Minimum Firmware Version Required: 1.xA0

Remote nodes will set up a random hold-off time based on this time. The remotes will adjust this time down by 250 ms to give each node the ability to respond before the base ends the command. Once the ND command has ended, any response received on the base would be discarded.

**P0 (PWM0 Configuration) Command**

<I/O Setting {I/O Line Passing}>

The P0 command is used to select/read the function for PWM0 (Pulse Width Modulation output 0). This command enables the option of translating incoming data to a PWM so that the output can be translated back into analog form.

With the IA (I/O Input Address) parameter correctly set, AD0 values can automatically be passed to PWM0.

AT Command: ATP0\_ The second character in the command is the number zero ("0"), not the letter "O".

Parameter Range: 0 - 2

Parameter	Configuration
0	Disabled
1	RSSI
2	PWM0 Output

Default Parameter Value: 1

**P1 (PWM1 Configuration) Command**

<I/O Setting {I/O Line Passing}>

The P1 command is used to select/read the function for PWM1 (Pulse Width Modulation output 1). This command enables the option of translating incoming data to a PWM so that the output can be translated back into analog form.

With the IA (I/O Input Address) parameter correctly set, AD1 values can automatically be passed to PWM1.

AT Command: ATP1

Parameter Range: 0 - 2

Parameter	Configuration
0	Disabled
1	RSSI
2	PWM1 Output

Default Parameter Value: 0

Minimum Firmware Version Required: v1.xA0

**PL (Power Level) Command**

<RF Interfacing> The PL command is used to select and read the power level at which the RF module transmits conducted power.

WHEN OPERATING IN EUROPE: modem must be configured to operate at a maximum transmit power output level of 10 dBm. The PL parameter must equal "0" (10 dBm).

Additionally, European regulations stipulate an EIRP power maximum of 12.86 dBm (19 mW) for the modem and 12.11 dBm for the modem when integrating high-gain antennas.

AT Command: ATPL

Parameter Range: 0 - 4

Parameter		
0	-10 dBm	10 dBm
1	-6 dBm	12 dBm
2	-4 dBm	14 dBm
3	-2 dBm	16 dBm
4	0 dBm	18 dBm

Default Parameter Value: 4

**PR (Pull-up Resistor Enable)**

**Command**

<Serial Interfacing> The PR command is used to set and read the bit field that is used to configure internal the pull-up resistor status for I/O lines. "1" specifies the pull-up resistor is enabled. "0" specifies no pull up.

- bit 0 - AD4/DIO4 (pin 11)
- bit 1 - AD3/DIO3 (pin 17)
- bit 2 - AD2/DIO2 (pin 18)
- bit 3 - AD1/DIO1 (pin 19)
- bit 4 - AD0/DIO0 (pin 20)
- bit 5 - AD6/DIO6 (pin 16)
- bit 6 - DI8 (pin 9)
- bit 7 - DIN/CONFIG (pin 3)

For example: Sending the command "ATPR 6F" will turn bits 0, 1, 2, 3, 5 and 6 ON; and bits 4 & 7 will be turned OFF. (The binary equivalent of "0x6F" is "01101111". Note that 'bit 0' is the last digit in the bitfield.

AT Command: ATPR

Parameter Range: 0 - 0xFF

Default Parameter Value: 0xFF \_ (all pull-up resistors are enabled)

Minimum Firmware Version Required: v1.x80

**PT (PWM Output Timeout)**

**Command**

<I/O Settings {I/O Line Passing}> The PT command is used to set/read the output timeout value for both PWM outputs.

When PWM is set to a non-zero value: Due to I/O line passing, a time is started which when expired will set the PWM output to zero. The timer is reset when a valid I/O packet is received.

AT Command: ATPT

Parameter Range: 0 - 0xFF [x 100 msec]

Default Parameter Value: 0xFF

Minimum Firmware Version Required: 1.xA0

**RE (Restore Defaults) Command**

<(Special)> The RE command is used to restore all configurable parameters to their factory default settings. The RE command does not write restored values to non-volatile (persistent) memory. Issue the WR (Write) command subsequent to issuing the RE command to save restored parameter values to non-volatile memory.

AT Command: ATRE

**RN (Random Delay Slots)**

**Command**

<Networking & Security> The RN command is used to set and read the minimum value of the back-off exponent in the CSMA-CA algorithm. The CSMA-CA algorithm was engineered for collision avoidance (random delays are inserted to prevent data loss caused by data collisions).

If RN = 0, collision avoidance is disabled during the first iteration of the algorithm (802.15.4 - macMinBE).

AT Command: ATRN

Parameter Range: 0 - 3 [exponent]

Default Parameter Value: 0

CSMA-CA stands for "Carrier Sense Multiple Access - Collision Avoidance". Unlike CSMA-CD (reacts to network transmissions after collisions have been detected), CSMA-CA acts to prevent data collisions before they occur. As soon as a module receives a packet that is to be transmitted, it checks if the channel is clear (no other module is transmitting). If the channel is clear, the packet is sent over-the-air. If the channel is not clear, the module waits for a randomly selected period of time, then checks again to see if the channel is clear. After a time, the process ends and the data is lost.

**RO (Packetization Timeout)**

**Command**

<Serial Interfacing> RO command is used to set and read the number of character times of intercharacter delay required before transmission.

AT Command: ATRO

Parameter Range: 0 - 0xFF [x character times]

Default Parameter Value: 3

RF transmission commences when data is detected in the DI (data in from host) buffer and RO character times of silence are detected on the UART receive lines (after receiving at least 1 byte).

RF transmission will also commence after 100 Bytes (maximum packet size) are received in the DI buffer.

Set the RO parameter to '0' to transmit characters as they arrive instead of buffering them into one RF packet.

**RP (RSSI PWM Timer)**

**Command**

<I/O Settings {I/O Line Passing}>

The RP command is used to enable PWM (Pulse Width Modulation) output on the RF

module. The output is calibrated to show the level a received RF signal is above the sensitivity level of the module. The PWM pulses vary from 24 to 100%. Zero percent means PWM output is inactive. One to 24% percent means the received RF signal is at or below the published sensitivity level of the module. The following table shows levels above sensitivity and PWM values.

AT Command: ATRP

Parameter Range: 0 - 0xFF  
[x 100 msec]

Default Parameter Value: 0x28 (40 decimal)

The total period of the PWM output is 64  $\mu$ s. Because there are 445 steps in the PWM output, the minimum step size is 144 ns.

**PWM Percentages**

dB above Sensitivity	PWM percentage (high period / total period)
10	41%
20	58%
30	75%

A non-zero value defines the time that the PWM output will be active with the RSSI value of the last received RF packet. After the set time when no RF packets are received, the PWM output will be set low (0 percent PWM) until another RF packet is received. The PWM output will also be set low at power-up until the first RF packet is

received. A parameter value of 0xFF permanently enables the PWM output and it will always reflect the value of the last received RF packet.

**RR Command**

<Networking {Addressing}> The RR command is used set/read the maximum number of retries the module will execute in addition to the 3 retries provided by the 802.15.4 MAC.

AT Command: ATRR

Parameter Range: 0 - 6

Default: 0

Minimum Firmware Version Required: 1.xA0

This values does not need to be set on all modules for retries to work. If retries are enabled, the transmitting module will set a bit in the B&B RF Packet header which requests the receiving module to send an ACK (acknowledgement). If the transmitting module does not receive an ACK within 200 msec, it will re-send the packet within a random period up to 48 msec. Each retry can potentially result in the MAC sending the packet 4 times (1 try plus 3 retries). Note that retries are not attempted for packets that are purged when transmitting with a Cyclic Sleep Coordinator.

**SC (Scan Channels) Command**

<Networking {Association}> The SC command is used to set and read the list of channels to scan for all Active and Energy Scans as a bit field.

AT Command: ATSC

Parameter Range: 0 - 0xFFFF

Default Parameter Value: 0x1FFE

This affects scans initiated in command mode [AS (Active Scan) and ED (Energy Scan) commands] and during End Device Association and Coordinator startup.

Related Commands: ED (Energy Scan), SD (Scan Duration)

Minimum Firmware Version Required: v1.x80

bit 0 - 0x0B	bit 4 - 0x0F bit
bit 1 - 0x0C	bit 5 - 0x10
bit 2 - 0x0D	bit 6 - 0x11
bit 3 - 0x0E	bit 7 - 0x12

8 - 0x13 bit	12 - 0x17
bit 9 - 0x14	bit 13 - 0x18
bit 10 - 0x15	bit 14 - 0x19
bit 11 - 0x16	bit 15 - 0x1A

**SD (Scan Duration) Command**

<Networking {Association}> The SD command is used to set and read the exponent value that determines the duration (in time) of a scan.

AT Command: ATSD

Parameter Range: 0 - 0x0F

Default Parameter Value: 4

Related Commands: ED (Energy Scan), SC (Scan Channel)

Minimum Firmware Version Required: v1.x80

**End Device** (Duration of Active Scan during Association) - In a Beacon system, set SD = BE of the Coordinator. SD must be set at least to the highest BE parameter of any Beaconsing Coordinator with which an End Device or Coordinator wish to discover.

**Coordinator** - If the 'ReassignPANID' option is set on the Coordinator [refer to A2 parameter], the SD parameter determines the length of time the Coordinator will scan channels to locate existing PANs. If the 'ReassignChannel' option is set, SD

determines how long the Coordinator will perform an Energy Scan to determine which channel it will operate on.

Scan Time is measured as ((# of Channels to Scan) \* (2 ^ SD) \* 15.36ms). The number of channels to scan is set by the SC command. The modem can scan up to 16 channels (SC = 0xFFFF).

**Examples: Values below show results for a 12 channel scan**

If SD = 0, time = 0.18 sec	SD = 8, time = 47.19 sec
SD = 2, time = 0.74 sec	SD = 10, time = 3.15 min
SD = 4, time = 2.95 sec	SD = 12, time = 12.58 min
SD = 6, time = 11.80 sec	SD = 14, time = 50.33 min

**SH (Serial Number High)**

**Command**

<Diagnostics> The SH command is used to read the high 32 bits of the RF module's unique IEEE 64-bit address.

AT Command: ATSH

Parameter Range: 0 - 0xFFFFFFFF [read-only]

Related Commands: SL (Serial Number Low), MY (Source Address)

The module serial number is set at the factory and is read-only.

**SL (Serial Number Low)**

**Command**

<Diagnostics> The SL command is used to read the low 32 bits of the RF module's unique IEEE 64-bit address.

AT Command: ATSL

Parameter Range: 0 - 0xFFFFFFFF [read-only]

Related Commands: SH (Serial Number High), MY (Source Address)

The module serial number is set at the factory and is read-only.

**SM (Sleep Mode) Command**

<Sleep Mode (Low Power)> The SM command is used to set and read Sleep Mode settings. By default, Sleep Modes are disabled (SM = 0) and the RF module remains in Idle/Receive Mode. When in this state, the module is constantly ready to respond to either serial or RF activity.

SM command options vary according to the networking system type. By default, the module is configured to operate in a NonBeacon system.

\* The Sleep Coordinator option (SM=6) only exists for backwards compatibility with firmware version 1.x06 only. In all other cases, use the CE command to enable a Coordinator.

AT Command: ATSM

Parameter Range: 0 - 6

Parameter	Configuration
0	Disabled
1	Pin Hibernate
2	Pin Doze
3	(reserved)
4	Cyclic Sleep Remote
5	Cyclic Sleep Remote (with Pin Wake-up)
6	Sleep Coordinator*

Default Parameter Value: 0

Related Commands: SP (Cyclic Sleep Period), ST (Time before Sleep)

**SP (Cyclic Sleep Period) Command**

<Sleep Mode (Low Power)> The SP command is used to set and read the duration of time in which a remote RF module sleeps. After the cyclic sleep period is over, the module wakes and checks for data. If data is not present, the module goes back to sleep. The maximum sleep period is 268 seconds (SP = 0x68B0).

The SP parameter is only valid if the module is configured to operate in Cyclic Sleep (SM = 4-6). Coordinator and End Device SP values should always be equal.

To send Direct Messages, set SP = 0.

**NonBeacon Firmware**

*End Device* - SP determines the sleep period for cyclic sleeping remotes. Maximum sleep period is 268 seconds (0x68B0).

*Coordinator* - If non-zero, SP determines the time to hold an indirect message before discarding it. A Coordinator will discard indirect messages after a period of (2.5 \* SP).

AT Command: ATSP

Parameter Range:	NonBeacon Firmware: 1 - 0x68B0 [x 10 milliseconds]
Default Parameter Value:	NonBeacon Firmware: 0

Related Commands: SM (Sleep Mode), ST (Time before Sleep), DP (Disassociation Cyclic Sleep Period, BE (Beacon Order)

**ST (Time before Sleep)**

**Command**

<Sleep Mode (Low Power)> The ST command is used to set and read the period of inactivity (no serial or RF data is sent or received) before activating Sleep Mode.

**NonBeacon Firmware**

Set/Read time period of inactivity (no serial or RF data is sent or received) before activating Sleep Mode. ST parameter is only valid with Cyclic Sleep settings (SM = 4 - 5).

AT Command: ATST

Parameter Range:	NonBeacon Firmware: 1 - 0xFFFF [x 1 millisecond]
Default Parameter Value:	NonBeacon Firmware: 0x1388 (5000 decimal)
Related Commands: SM (Sleep Mode), ST (Time before Sleep)	

Coordinator and End Device ST values must be equal.

**T0 - T7 ((D0-D7) Output Timeout)**

**Command**

<I/O Settings {I/O Line Passing}>

The T0, T1, T2, T3, T4, T5, T6 and T7 commands are used to set/read output timeout values for the lines that correspond with the D0 - D7 parameters. When output is set (due to I/O line passing) to a nondefault level, a timer is started which when expired, will set the output to its default level. The timer is reset when a valid I/O packet is received. The Tn parameter defines the permissible amount of time to stay in a non-default (active) state. If Tn = 0, Output Timeout is disabled (output levels are held indefinitely).

AT Commands: ATT0 - ATT7

Parameter Range:	0 - 0xFF [x 100 msec]
Default Parameter Value:	0xFF
Minimum Firmware Version Required: v1.xA0	

**VL (Firmware Version - Verbose)**

<Diagnostics> The VL command is used to read detailed version information about the RF module. The information includes: application build date; MAC, PHY and bootloader versions; and build dates.

AT Command: ATVL

Parameter Range:	0 - 0xFF [x 100 milliseconds]
Default Parameter Value:	0x28 (40 decimal)
Minimum Firmware Version Required: v1.x80	

**VR (Firmware Version) Command**

<Diagnostics> The VR command is used to read which firmware version is stored in the module.

AT Command: ATVR

Parameter Range:	0 - 0xFFFF [read only]
------------------	------------------------

Version numbers will have four significant digits. The reported number will show three or four numbers and is stated in hexadecimal notation. A version can be reported as "ABC" or "ABCD". Digits ABC are the main release number and D is the revision number from the main release. "D" is not required and if it is not present, a zero is assumed for D. "B" is a variant designator. The following variants exist:

- "0" = Non-Beacon Enabled 802.15.4 Code
- "1" = Beacon Enabled 802.15.4 Code

### WR (Write) Command

<(Special)> The WR command is used to write configurable parameters to the RF module's nonvolatile memory. Parameter values remain in the module's memory until overwritten by subsequent use of the WR Command.

---

AT Command: ATWR

---

If changes are made without writing them to non-volatile memory, the module reverts back to previously saved parameters the next time the module is powered-on.

---

NOTE: Once the WR command is sent to the module, no additional characters should be sent until after the "OK/r" response is received.

## API Operation

By default, Zlinx Radio Modems act as a serial line replacement (Transparent Operation) - all UART data received through the DI pin is queued up for RF transmission. When the module receives an RF packet, the data is sent out the DO pin with no additional information.

Inherent to Transparent Operation are the following behaviors:

- If module parameter registers are to be set or queried, a special operation is required for transitioning the module into Command Mode.
- In point-to-multipoint systems, the application must send extra information so that the receiving module(s) can distinguish between data coming from different remotes.

As an alternative to the default Transparent Operation, API (Application Programming Interface) Operations are available. API operation requires that communication with the module be done through a structured interface (data is communicated in frames in a defined order). The API specifies how commands, command responses and module status messages are sent and received from the module using a UART Data Frame.

### API Frame Specifications

Two API modes are supported and both can be enabled using the AP (API Enable) command. Use the following AP parameter values to configure the module to operate in a particular mode:

- AP = 0 (default): Transparent Operation (UART Serial line replacement) API modes are disabled.
- AP = 1: API Operation
- AP = 2: API Operation (with escaped characters)

Any data received prior to the start delimiter is silently discarded. If the frame is not received correctly or if the checksum fails, the data is silently discarded.

**API Operation (AP parameter = 1)**

When this API mode is enabled (AP = 1), the UART data frame structure is defined as follows:

**UART Data Frame Structure:**



MSB = Most Significant Byte, LSB = Least Significant Byte

**API Operation - with Escape Characters (AP parameter = 2)**

When this API mode is enabled (AP = 2), the UART data frame structure is defined as follows:

**UART Data Frame Structure with escape control characters:**

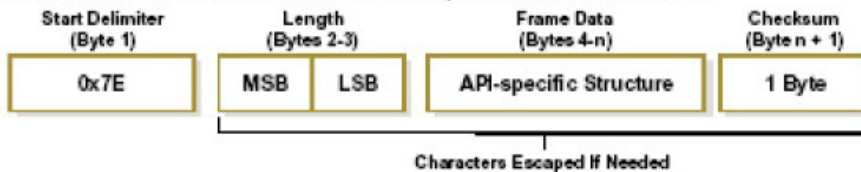

MSB = Most Significant Byte, LSB = Least Significant Byte

**Escape characters.** When sending or receiving a UART data frame, specific data values must be escaped (flagged) so they do not interfere with the UART or UART data frame operation. To escape an interfering data byte, insert 0x7D and follow it with the byte to be escaped XOR'd with 0x20.

**Data bytes that need to be escaped:**

- 0x7E – Frame Delimiter
- 0x7D – Escape
- 0x11 – XON
- 0x13 – XOFF

**Example - Raw UART Data Frame (before escaping interfering bytes):**

0x7E 0x00 0x02 0x23 0x11 0xCB

0x11 needs to be escaped which results in the following frame:

0x7E 0x00 0x02 0x23 0x7D 0x31 0xCB

Note: In the above example, the length of the raw data (excluding the checksum) is 0x0002 and the checksum of the non-escaped data (excluding frame delimiter and length) is calculated as:

$$0xFF - (0x23 + 0x11) = (0xFF - 0x34) = 0xCB.$$

**Checksum**

To test data integrity, a checksum is calculated and verified on non-escaped data.

**To calculate:** Not including frame delimiters and length, add all bytes keeping only the lowest 8 bits of the result and subtract from 0xFF.

**To verify:** Add all bytes (include checksum, but not the delimiter and length). If the checksum is correct, the sum will equal 0xFF.

### 3.4.2. API Types

Frame data of the UART data frame forms an API-specific structure as follows:

#### UART Data Frame & API specific Structure:

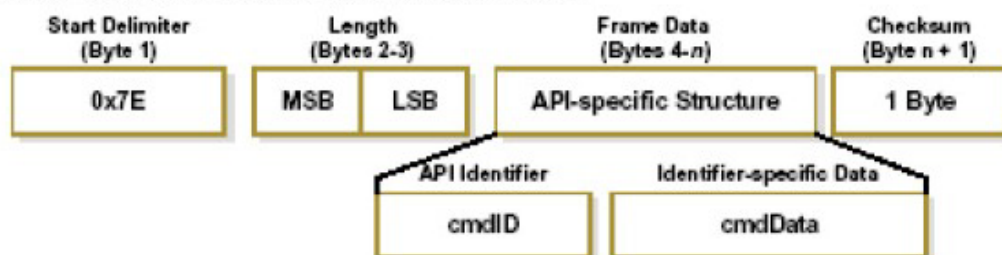

The **cmdID** frame (API-identifier) indicates which API messages will be contained in the **cmdData** frame (Identifier-specific data). Refer to the sections that follow for more information regarding the supported API types. Note that multi-byte values are sent big endian.

#### Modem Status

API Identifier: 0x8A

RF module status messages are sent from the module in response to specific conditions.

#### Modem Status Frames

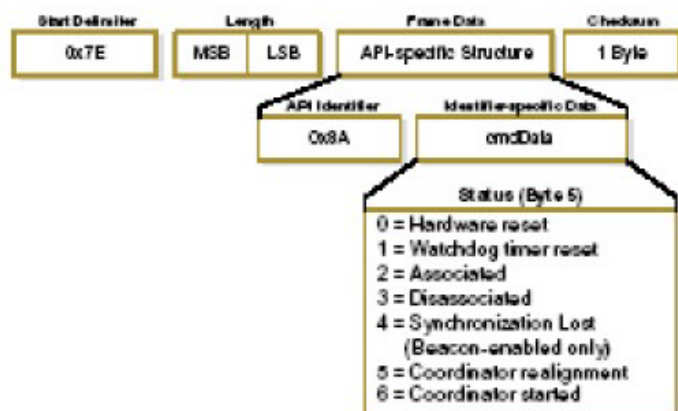

**AT Command**

API Identifier Value: 0x08

The "AT Command" API type allows for module parameters to be queried or set. When using this command ID, new parameter values are applied immediately. This includes any register set with the "AT Command - Queue Parameter Value" (0x09) API type.

**AT Command Frames**

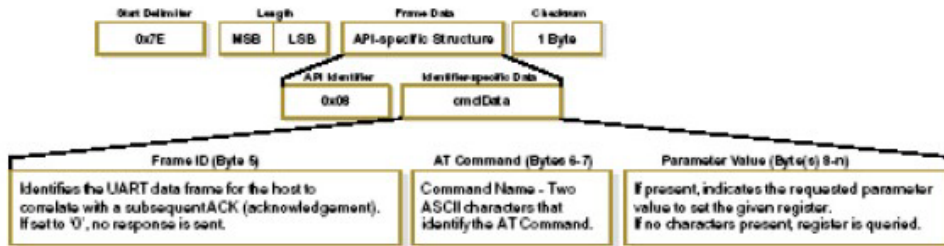

Example: API frames when reading the DL parameter value of the module.

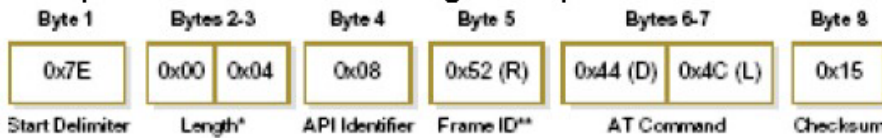

\* Length [Bytes] = API Identifier + Frame ID + AT Command  
 \*\* "R" value was arbitrarily selected.

Example: API frames when modifying the DL parameter value of the module.



\* Length [Bytes] = API Identifier + Frame ID + AT Command + Parameter Value  
 \*\* "M" value was arbitrarily selected.

**AT Command - Queue Parameter Value**

API Identifier Value: 0x09

This API type allows module parameters to be queried or set. In contrast to the "AT Command" API type, new parameter values are queued and not applied until either the "AT Command" (0x08) API type or the AC (Apply Changes) command is issued. Register queries (reading parameter values) are returned immediately.

**AT Command Frames**

(Note that frames are identical to the "AT Command" API type except for the API identifier.)

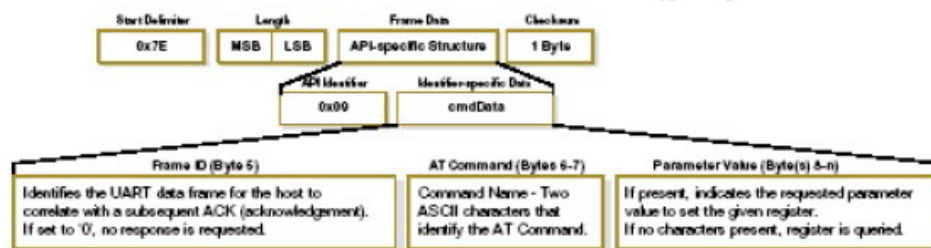

### AT Command Response

API Identifier Value: 0x88

Response to previous command.

In response to an AT Command message, the module will send an AT Command Response message. Some commands will send back multiple frames (for example, the ND (Node Discover) and AS (Active Scan) commands). These commands will end by sending a frame with a status of ATCMD\_OK and no cmdData.

### AT Command Response Frames.

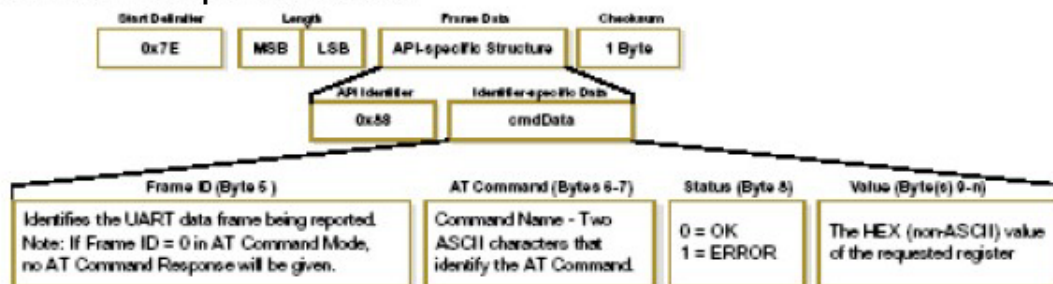

### TX (Transmit) Request: 64-bit address

API Identifier Value: 0x00

A TX Request message will cause the module to send RF Data as an RF Packet.

### TX Packet (64 bit address) Frames

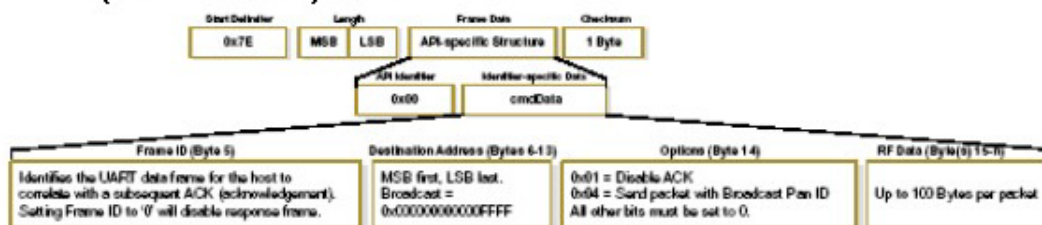

### TX (Transmit) Request: 16-bit address

API Identifier Value: 0x01

A TX Request message will cause the module to send RF Data as an RF Packet.

### TX Packet (16 bit address) Frames

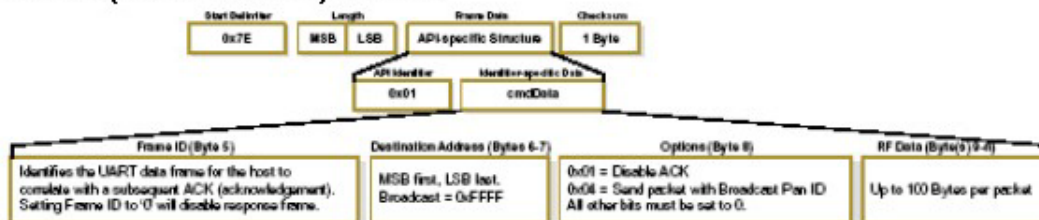

**TX (Transmit) Status**

API Identifier Value: 0x89

When a TX Request is completed, the module sends a TX Status message. This message will indicate if the packet was transmitted successfully or if there was a failure.

**TX Status Frames**

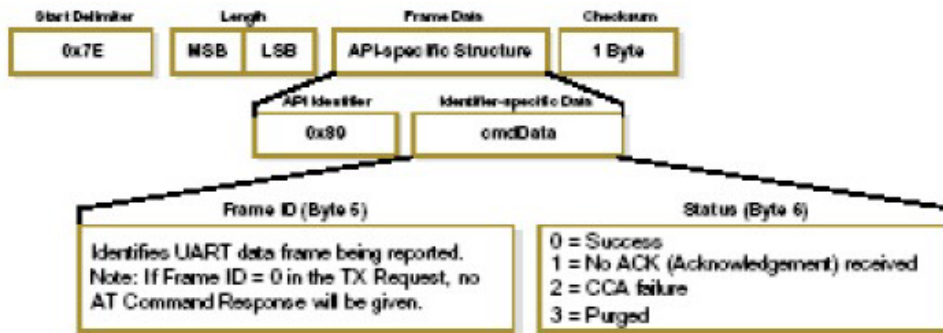

**NOTES:**

- "STATUS = 1" occurs when all retries are expired and no ACK is received.
- If transmitter broadcasts (destination address = 0x000000000000FFFF), only "STATUS = 0 or 2" will be returned.
- "STATUS = 3" occurs when Coordinator times out of an indirect transmission.

Timeout is defined as (2.5 x SP (Cyclic Sleep Period) parameter value).

**RX (Receive) Packet: 64-bit Address**

API Identifier Value: 0x80

When the module receives an RF packet, it is sent out the UART using this message type.

**RX Packet (64 bit address) Frames**

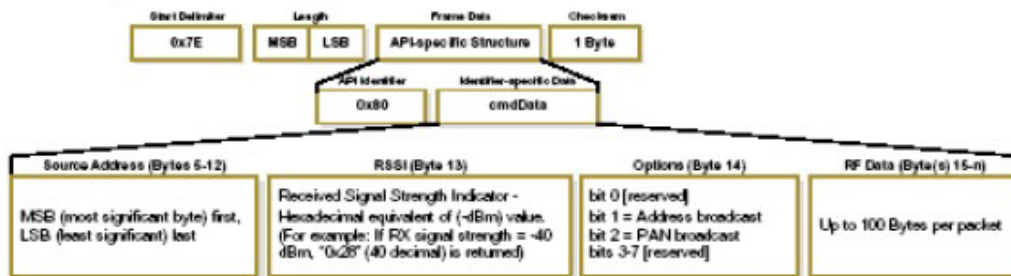

**RX (Receive) Packet: 16-bit Address**

API Identifier Value: 0x81

When the module receives an RF packet, it is sent out the UART using this message type.

### RX Packet (16 bit address) Frames

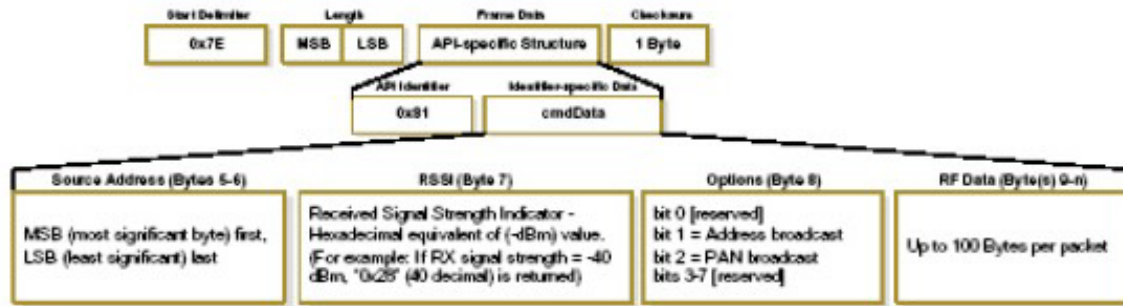

**6.6 FIRMWARE UPDATE**

**6.6.1 CAUTION**

*Note: A firmware update should never be interrupted before it is finished.*

**6.6.2 FIRMWARE UPDATE PROCEDURE**

1. Download the new firmware file and store it in the firmware directory:  
C:\Program Files\B+B SmartWorx\Zlinx\Zlinx Manager\update
2. Connect your PC to the radio modem using a USB cable.
3. From the manager launch screen, click on the radio modem firmware update link.



**Figure 6-2 Manager Launch Screen**

4. The radio modem communications parameters screen will appear. Verify the parameters and click the connect button.

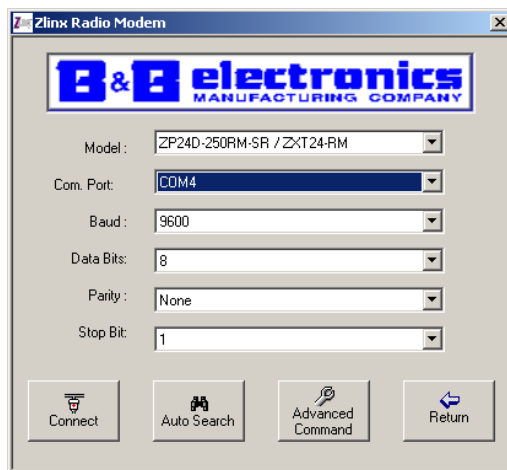

**Figure 6-3 Radio modem communications parameters screen**

5. Once connected, the software will determine which firmware versions are available on the PC and what version is loaded in the modem. The firmware updater screen will appear. This screen is used to choose which firmware version to load:

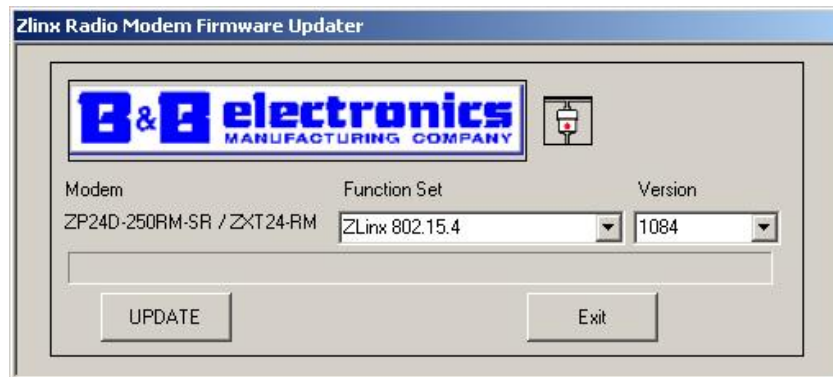

Firmware Updater Screen

6. Select the firmware and version from the pull-down menu.
7. Click the UPDATE button.
8. The progress bar will indicate that the firmware is being updated. Do not interrupt this process. When complete, you will be returned to firmware updater screen.

**7 - USE CASES**

**\*\* With any RF system it is best to set up and bench test before field installation. \*\***

**7.1 POINT-TO-POINT SERIAL**

**7.1.1 USE CASE PARAMETERS**

Serial RS-232 wire replacement. RS-232, 115.2 kbps, hardware flow control (CTS/RTS). 900 MHz Radio Modem with encryption.

**7.1.1.1 SETUP INSTRUCTIONS**

1. Wire your RS-232 devices and power as described in section three.
2. Connect to the modem using the USB port.
3. Configure both radio modems the same with the exception of the destination address.
4. Remember to save your new settings by clicking on the update button.
5. On the Basic Modem Settings Tab, ensure ZXT9-RM is displayed in the model number box

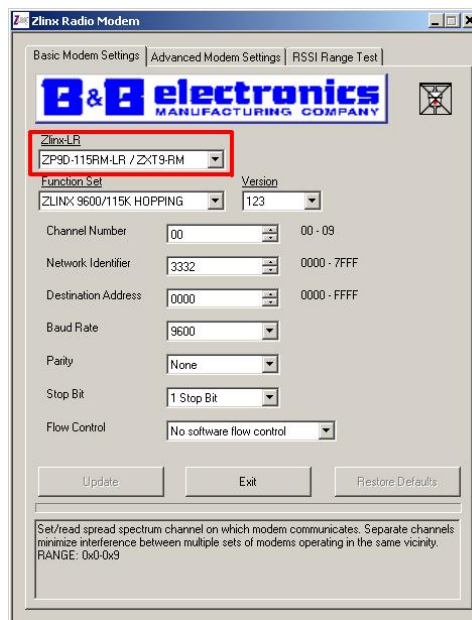

6. Select a unique channel number. This is the same for both radio modems.



7. Select a unique Network Identifier. This is the same for both radio modems

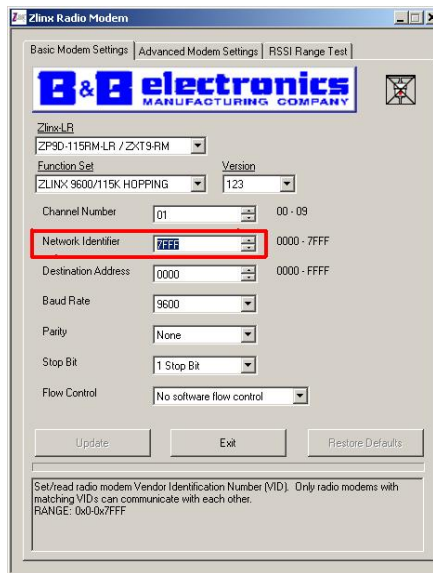

8. Select a destination address. This should be different for each radio modem. For example, radio modem number 1 could be 0001 and radio modem number two could be 0002. Another option is to leave the destination address at its default value of 0000 and proceed to the next step.

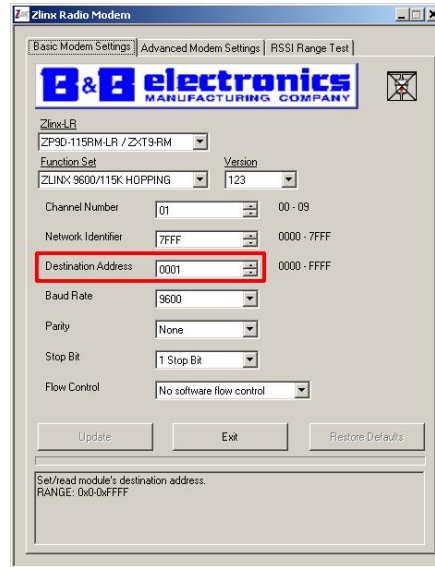

9. On the Advanced Modem Settings Tab, under the Networking and Security Tab, select the Source Address (MY – Source Address). This sets the address of the modem and should be comparable with the destination addresses set above. For example, if you set the destination address on modem number two to 0002, the source address on modem number one should be 0002. Another option is to leave the source address at its default value of FFFF. When the source address is FFFF, the source and destination address are the same (FFFF). Because this could cause cross talk between networks, it is recommended that you select a unique source and destination address as previously described.

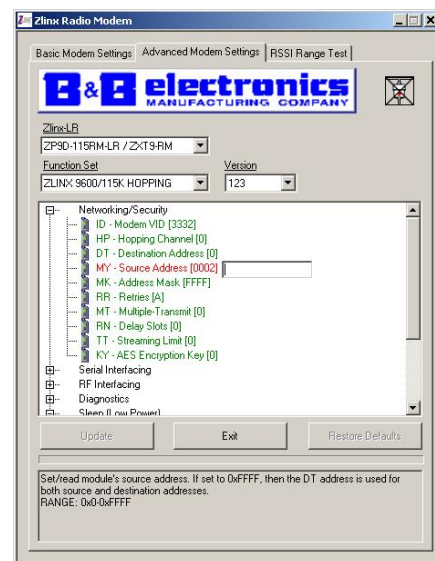

10. On the Basic Modem Settings Tab, select 115.2 kbps from the pull-down menu. This should be the same for both radio modems.

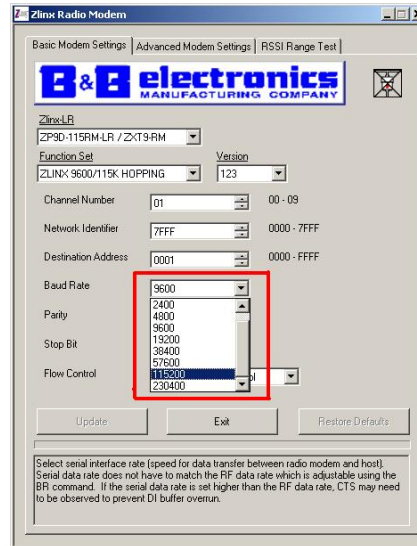

11. On the Basic Modem Settings Tab, select parity and stop bit as desired.



12. Save settings by clicking the update button.

13. On the Advanced Modem Settings Tab, set encryption. Under the Networking/Security tree, double click the KY – AES Encryption Key. A button will appear that says “set”. Click on this button.

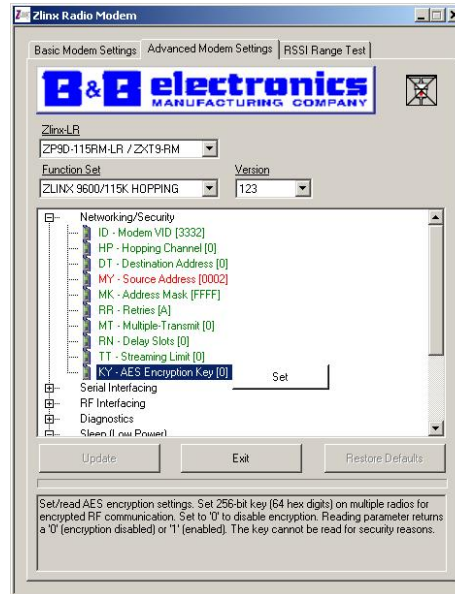

14. The key entry box will appear. Enter up to 64 HEX digits and click OK. Click the Update Button to save the key.  
**Record this key and save in a safe location.**

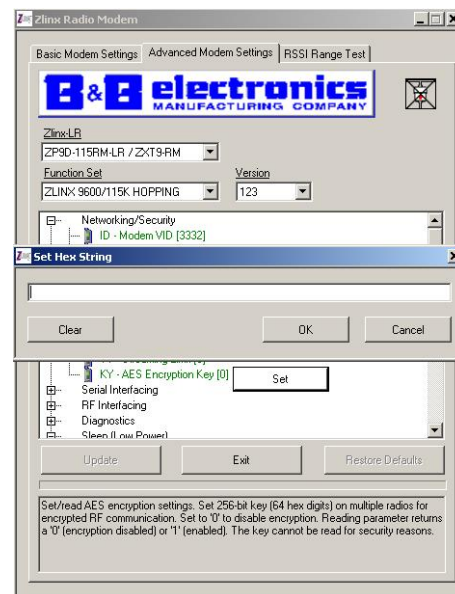

15. Set the same key on the other radio modem.
16. Your radio modems are now configured. It is recommended to bench test this configuration before installing in the field.

**7.2 POINT-TO-POINT SERIAL TO XTREME I/O**

**7.2.1 USE CASE PARAMETERS**

In this parameter, a radio modem is being used to connect PLC or similar device to a remote Xtreme I/O module.

1. Wire the radio modem input and power as described in section three.
2. Configure the radio modem as described in section 7.1.1.1.
3. Configure the I/O module radio settings to match the radio modem.

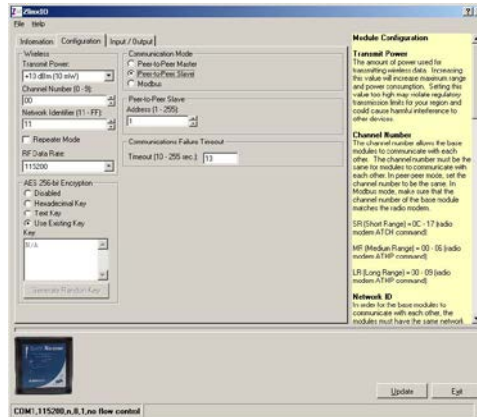

4. Channel Number must match the channel selected in section 7.3 step 6.
5. Network identifier must match the network identifier selected in section 7.1.1.1 step 7.
6. Set the Modem RF data rate to match the I/O module. On the Advanced Modem Settings tab, under the RF interfacing tab, click on BR- RF Data Rate and set the desired data rate from the pull-down menu.

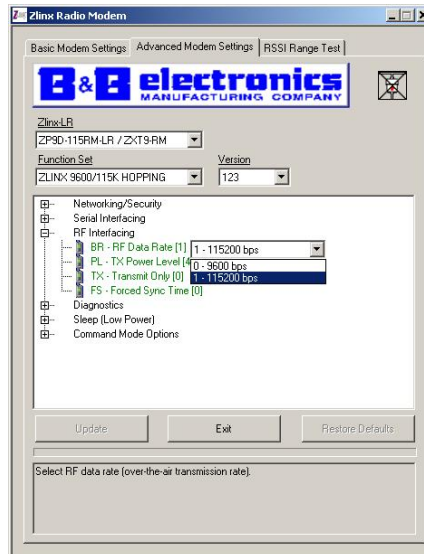

7. If encryption is being used, the same key must be used in the I/O module. The radio modem uses a hexadecimal string. When entering your key in the I/O module, you must enter it in HEX.
8. It is recommended that you bench test your configuration before installing it in the field.

8 - TESTING AND TROUBLE SHOOTING

8.1 RSSI RANGE TEST

The **RSSI Range Test** is used to check communication between two radio modems.

1. Connect the first modem to a computer running the Zlinx<sup>®</sup> Manager software. Set up the modem for RS-232 operation as described in Section Six.
2. Configure the second modem to RS-232 operation as described in Section Six. The second modem will also require a loop-back setup.
  - a. RS-232 Configuration
    - 1) Set Dip Switch 1 and 2 in the ON Position
3. In the Zlinx<sup>®</sup> Manager Software, click the RSSI Range Test Tab.

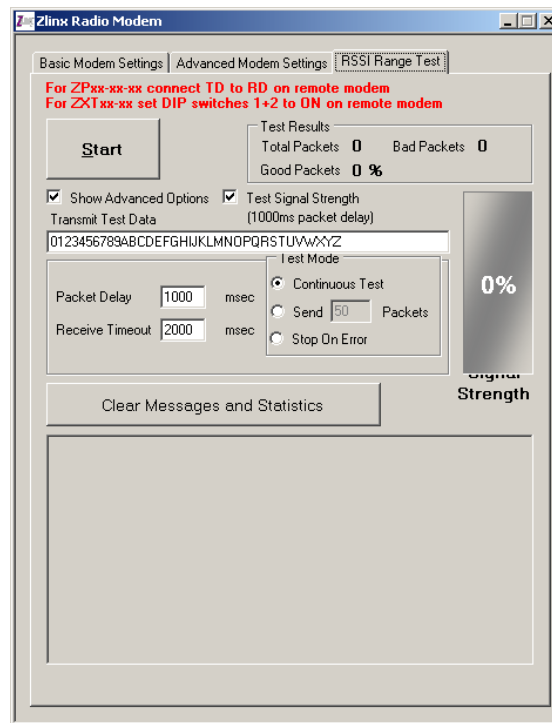

Figure 8-1 RSSI Range Test Screen

4. Press the 'Start' button in the Zlinx<sup>®</sup> Manager RSSI Range Test screen. The screen will change to show the results of the test.

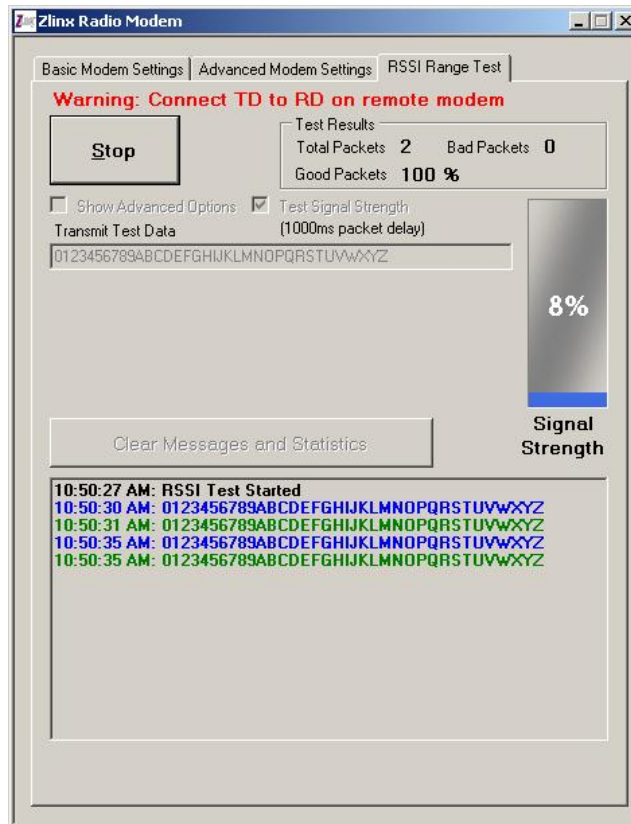

Figure 8-2 RSSI Range Test Results Screen

## 5. RSSI Range Test Features

- Test Results section of the screen shows the total packets sent. The section also shows the percentage of good packets received back from the modem.
- Test Signal Strength checkbox will turn on/off the Signal Strength value displaying graphically on the progress bar.
- The Start button will start the range test as configured. Once the test is running the button will be shown as Stop.
- The list box at the bottom will display all the received packet data both good and bad. It will display "Timeout waiting for data" for missed packets.
- Clear Messages and Statistics button will clear the list box and packet count/percentages for a clean start to a new test.
- The Show Advanced Options check box will toggle the advance test options on to the screen.

**APPENDIX A – SPECIFICATIONS**

<b>RF Properties</b>	
Physical Standard	IEEE 802.15.4
Frequency	ZXT9-RM – 900MHz ISM Band (902- 928 MHz)
	ZXT24-RM – 2.4 GHz ISM Band (2.4-2.5 GHz)
Transmit Power (ZXT9-RM)	1 mW 10 mW 100 mW 500 mW 1 W
Transmit Power (ZXT24-RM)	10 mW 16 mW 25 mW 30 mW 63 mW
Receiver Sensitivity (ZXT9-RM)	-100 dBm
Receiver Sensitivity (ZXT24-RM)	-100 dBm
Over-the-Air Data Rate	ZXT9-RM – 9.6 kbps or 115.2 kbps (software selectable) ZXT24-RM – 250 kbps (fixed)
Range Outdoor (ZXT9-RM)	Supplied Antenna – 14 Miles (23 Kilometers) High Gain Antenna – 40 Miles (64 Kilometers)
Range Outdoor (ZXT24-RM)	Supplied Antenna – 1.5 Miles (2.4 Kilometers) High Gain Antenna – 10 Miles (16 Kilometers)
	<b>Range estimates based on optimal RF conditions and an unobstructed line of sight.</b>
Transmission Method Sensitivity (ZXT9-RM)	Frequency Hopping Spread Spectrum (FHSS)
Transmission Method Sensitivity (ZXT24-RM)	Direct Sequence Spread Spectrum (DSSS)
Modulation	FSK (Frequency Shift Keying)
Channel Capacity (ZXT9-RM)	10 hop sequences share 50 frequencies
Channel Capacity (ZXT24-RM)	12 Direct Sequence Channels
Network Topologies	Peer-to-Peer, Point-to-Point, Point-to-Multipoint
Encryption (ZXT9-RM)	256-bit AES
<b>Software</b>	Zlinx Manager
Support	Windows (32 and 64 bit): XP, 7, Vista, 8, 8.1, 10
<b>Antenna Options</b>	RPSMA Connector
<b>Radio Address</b>	Software Selectable
<b>Serial Settings</b>	
Baud (ZXT9-RM)	1.2 kbps to 230.4 kbps
Baud (ZXT24-RM)	1.2 kbps to 115.2 kbps
Data Bit	8

Parity	None
Stop Bit	1
<b>RS-232</b>	
Connector	Terminal block
Lines	TD, RD, RTS, CTS, GND
<b>RS-422</b>	
Connector	Terminal Block
Lines	TDA (-), TDB(+), RDA (-), RDB (+), GND
Termination	120 Ohm selectable (in or out)
<b>RS-485 (2/4 Wire)</b>	
Connector	Terminal Block
Lines	TDA (-), TDB(+), RDA (-), RDB (+), GND Data A (-), Data B (+), GND
SD Control	Automatic Bit Wise
Termination	120 Ohm Dipswitch selectable
<b>Link Fault Output</b>	No wireless signal or RSSI LED's off
Connector	Terminal Block
Output type	Open drain 50mA (PNP – Sourcing)
<b>Power Supply</b>	
Connector	Terminal Block
Input Voltage	10–30 VDC
Power Consumption (ZXT9-RM)	1.7 Watts, typical 5.8 Watts, maximum
Power Consumption (ZXT24-RM)	1.2 Watts, typical 3.5 Watts, maximum
<b>Dimensions</b>	5.12 x 5.12 x 2.37 in (130.1 x 130.1 x 60.2 mm)
<b>Environmental</b>	Intended for indoor and outdoor use
Operating Temperature	-40 to +74 °C (-40 to +165 °F)
Storage Temperature	-40 to +85 °C (-40 to +185 °F)
Operating Humidity	0 to 95% non-condensing
<b>Enclosure Rating</b>	
Rating	IP67
Mounting	Wall mount
<b>Agency Approvals</b>	
CE	EN55022: 2006 Class A Emissions EN61000-6-2 Generic Standards for Industrial Environments
FCC	Class A FCC ID – ZXT9-RM – OUR-9XTEND FCC ID – ZXT24-RM – OUR-XBEEPRO

<b>LED Status</b>	<b>Front Panel LED</b>	<b>Status</b>
	RSSI (Signal Strength)	8 Green LED's indicate signal from weak to strong
	Power	Green LED
	Receive Data	Green LED – blinks when Serial data is received
	Transmit Data	Green LED – blinks when Serial data is transmitted.
<p><b>Note:</b> In order for the RSSI LED to continuously indicate the signal strength, set the RP command (RSSI PWM Timer) to FF.</p>		

## APPENDIX B – DEFAULT CONFIGURATIONS

### B.1 RESTORE DEFAULT CONFIGURATIONS

Push Button 1 – Located behind the cover in the upper right corner.

Used to restore default configuration

Refer to section 2.5.6 and figure 2-4.

### B.2 ZXT9-RM DEFAULT CONFIGURATION

#### **Basic Modem Settings**

Channel Number – 00

Network Identifier – 3332

Destination Address – 0000

Baud Rate – 9600

Parity None

Stop Bit – 1 Stop Bit

Flow Control – No Software Flow Control

#### **Advanced Modem Settings**

##### ***Networking & Security***

ID – Modem VID – 3332

HP – Hopping Channel – 0

DT – Destination Address – 0

MY – Source Address – FFFF

MK – Address Mask – FFFF

RR – Retries – A

MT – Multiple Transmit – 0

RN – Delay Slots – 0

TT – Streaming Limit – 0

KY – AES Encryption Key – 0

##### ***Serial Interfacing***

BD – Baud Rate – 3

NB – Parity – 3

SB – Stop Bits – 0

RB – Packetization Threshold – 2048

PK – Maximum RF Packet Size – 3

CS – Pin 9 Configuration – 0

RT – Pin 9 Configuration – 0

CD – Pin 3 Configuration – 3

FL – Software Flow Control – 0

FT – Flow Control Threshold – BEF

##### ***RF Interfacing***

BR – RF Data Rate – 1

PL – TX Power Level – 4

TX – Transmit Only – 0

FS – Forced Sync Time – 0

**Diagnostics**

RP – RSSI Timer – 20

**Sleep (Low Power)**

SM – Sleep Mode – 0

ST – Time Before Sleep – 64

HT – Time Before Wake-up Initializer – FFFF

LH – Wake-up Initializer Timer – 1

PW – Pin Wake-up – 0

**Command Mode Options**

BT – Guard Time Before – A

CC – Command Sequence Character – 2B

AT – Guard Time After – A

CT – Command Mode Timeout – C8

**B.3 ZXT24-RM DEFAULT CONFIGURATION****Basic Modem Settings**

Channel Number – 0C

Network Identifier – 3332

Destination Address – 0000

Baud Rate – 9600

**Advanced Modem Settings****Network & Security**

CH – Channel – C

ID – Pan ID – 3332

DH – Destination Address High – 0

DL – Destination Address Low – 0

MY – 16 Bit Source Address – 0

RN – Random Delay Slots – 0

MM – MAC Mode – 0

CE – Coordinator Enable – 0

SC – Scan Channels – 1FFE

SD – Scan Duration – 4

A1 – End Device Association – 0

A2 – Coordinator Association – 0

**RF Interfacing**

PL – Power Level – 4

CA – CCA Threshold – 2C

**Sleep Mode (Non-beacon)**

SM – Sleep Mode – 0

ST – Time Before Sleep – 1388

SP – Cyclic Sleep Period – 0

DP – Disassociated Cyclic Sleep Period – 3E8

***Serial Interfacing***

BD – Interface Data Rate – 3  
RO – Packetization Timeout – 3  
D7 – DIO7 Configuration – 1  
D6 – DIO6 Configuration – 0  
D5 – DIO5 Configuration – 1  
P0 – PWM0 Configuration – 1  
AP – API Enable – 0  
PR – Pull-up Resistor Enable – FF

***Diagnostics***

RP – RSSI PWM Timer – 28

***AT Command Options***

CT – AT Command Mode Timeout – 64  
GT – Guard Times – 3E8  
CC – Command Sequence Character – 2B

APPENDIX C – DIMENSIONAL DIAGRAM / MOUNTING INSTRUCTIONS

C.1 DIMENSIONAL DIAGRAM

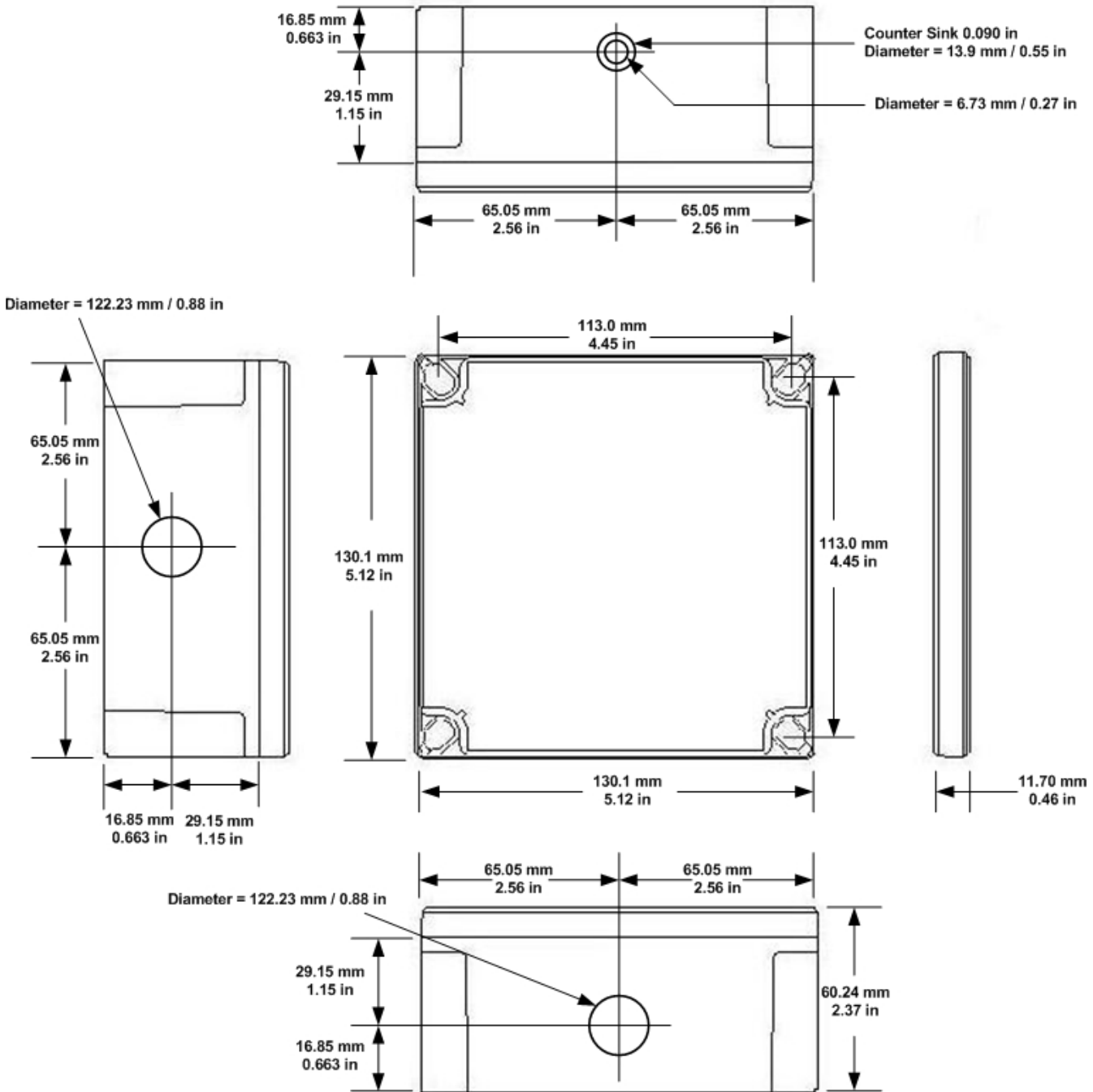

**C.2 MOUNTING**

The radio modem can be mounted directly to a panel or bulkhead or by attaching the supplied mounting ears. In either case, the cover must be removed to allow access to the screw pass-through holes. The mounting ears are packaged with screws. If you want to mount the device without using the ears, you will need to procure longer number 6 screws.

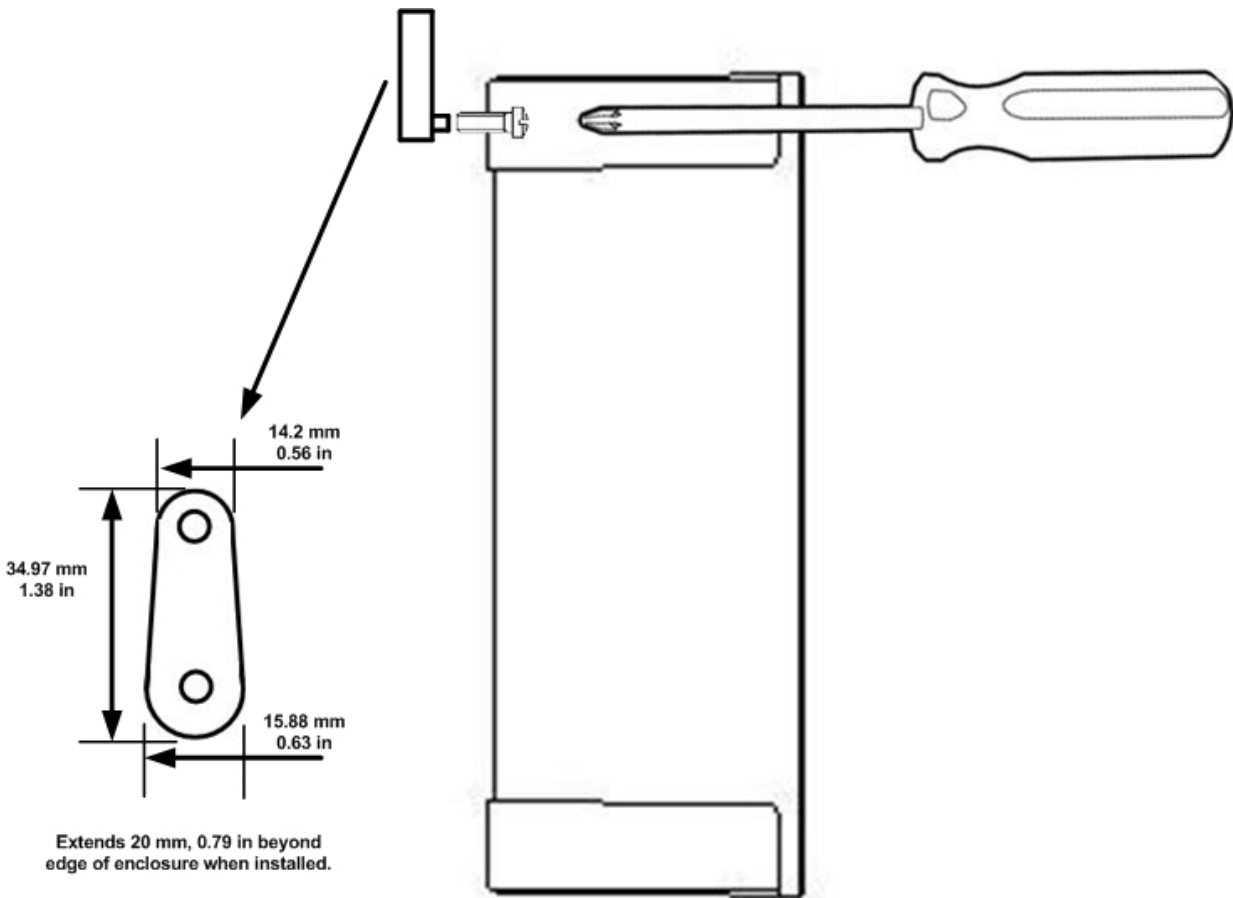

C.3 SUPPLIED ANTENNA

The supplied antenna has a male RPSMA connector. The antenna is attached to the female RPSMA jack on the enclosure. In order to operate, the antenna must be vertical.

900 MHz Antenna Mechanical Drawing:\

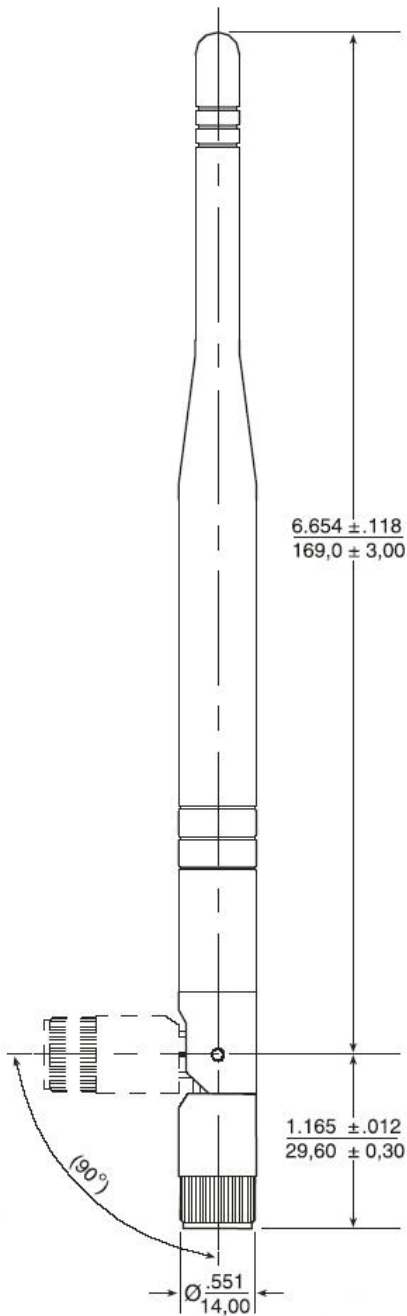

2.4 GHz Antenna Mechanical Drawing:

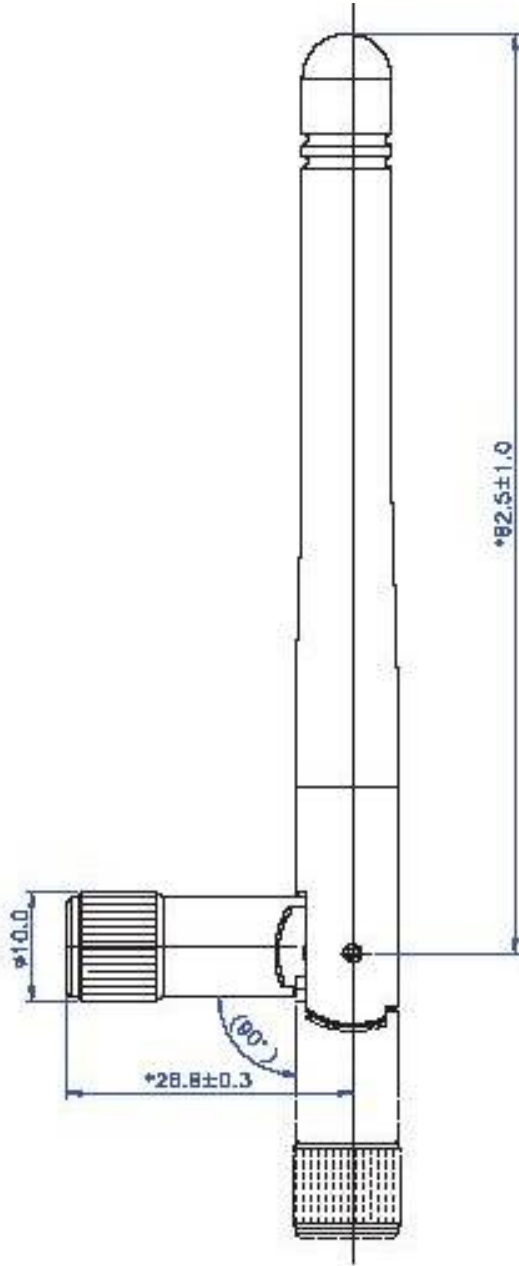

**APPENDIX D – RADIO FREQUENCY BASICS**

**D.1 WHAT IS DBM?**

Radio Frequency (RF) power is measured in milli-Watts (mW) or, more usefully, in a logarithmic scale of decibels (dB), or decibels referenced to 1 mW of power (dBm). Since RF power attenuates as a logarithmic function, the dBm scale is most useful. Here are some examples of how these scales relate:

1mW = 0dBm	A 2-fold increase in power yields 3dBm of signal.
2mW = 3dBm	A 10-fold increase in power yields 10dBm of signal.
4mW = 6dBm	A 100-fold increase in power yields 20dBm of signal.
10mW = 10dBm	
100mW = 20dBm	
1W = 30dBm	

**D.2 LOWER FREQUENCIES = BETTER PROPAGATION**

Industrial applications typically operate in “license free” frequency bands, also referred to as ISM (Industrial, Scientific and Medical). The frequencies and power of these bands varies from country to country. The most common frequencies encountered are:

2.4 GHz – nearly worldwide

915 MHz band – North America, South America, some other countries

As frequency rises, available bandwidth typically rises, but distance and ability to overcome obstacles is reduced. For any given distance, a 2.4 GHz installation will have roughly 8.5 dB of additional path loss when compared to 900 MHz. However, lower frequencies require larger antennas to achieve the same gain.

**D.3 RANGE IS NOT JUST A FUNCTION OF TRANSMITTER POWER**

The more sensitive the radio, the lower the power signal it can successfully receive, stretching right down to the noise floor. There is so much variety in “specsmanship” for radio sensitivity, that it is difficult to make a meaningful comparison between products. The most meaningful specification is expressed at a particular bit error rate and will be given for an ideal environment shielded from external noise. Unless you’re in a high RF noise environment (typically resulting from numerous similar-frequency radio transmitters located nearby), the odds are good that the noise floor will be well below the receive sensitivity, so the manufacturer’s rated receive sensitivity will be a key factor in your wireless system and range estimates.

You can often improve your receive sensitivity, and therefore your range, by reducing data rates over the air. Receive sensitivity is a function of the transmission baud rate so, as baud rate goes down, the receive sensitivity goes up. Many radios give the user the ability to reduce the baud rate to maximize range.

The receive sensitivity of a radio also improves at lower frequencies, providing another significant range advantage of 900 MHz (vs. 2.4 GHz) - as much as six to twelve dB!

## D.4 YOU MUST CONSIDER RF NOISE

RF background noise comes from many sources, ranging from solar activity to high frequency digital products to all forms of other radio communications. That background noise establishes a noise floor which is the point where the desired signals are lost in the background ruckus. The noise floor will vary by frequency.

Typically the noise floor will be lower than the receive sensitivity of your radio, so it will not be a factor in your system design. If, however, you're in an environment where high degrees of RF noise may exist in your frequency band, then use the noise floor figures instead of radio receive sensitivity in your calculations. If you suspect this is the case, a simple site survey to determine the noise floor value can be a high payoff investment.

When in doubt, look about. Antennas are everywhere nowadays - on the sides of buildings, water towers, billboards, chimneys, even disguised as trees. Many sources of interference may not be obvious.

## D.5 FADE MARGIN IS CRITICAL FOR RELIABLE OPERATION IN ADVERSE WEATHER AND INTERFERENCE

Fade margin is a term critical to wireless success. Fade margin describes how many dB a received signal may be reduced by without causing system performance to fall below an acceptable value. Walking away from a newly commissioned wireless installation without understanding how much fade margin exists is the number one cause of wireless woes.

Establishing a fade margin of no less than 10dB in good weather conditions will provide a high degree of assurance that the system will continue to operate effectively in a variety of weather, solar, and RF interference conditions.

There are a number of creative ways to estimate fade margin of a system without investing in specialty gear. Pick one or more of the following and use it to ensure you've got a robust installation:

Some radios have programmable output power. Reduce the power until performance degrades, then dial the power back up a minimum of 10dB. Remember again, doubling output power yields 3 dB, and an increase of 10dB requires a ten-fold increase in transmit power.

Invest in a small 10dB attenuator (pick the correct one for your radio frequency!). If you lose communications when you install the attenuator installed in-line with one of your antennas, you don't have enough fade margin.

Antenna cable is lossy, more so at higher frequencies. Specifications vary by type and manufacturer so check them yourself but, at 900MHz, a coil of RG58 in the range of 50 to 100 feet (15 to 30 m) will be 10dB. At 2.4GHz, a cable length of 20-40 feet (6 to 12 m) will yield 10dB. If your system still operates reliably with the test length of cable installed, you've got at least 10dB of fade margin.

## D.6 REMEMBER YOUR MATH

Contrary to popular opinion, no black art is required to make a reasonable prediction of the range of a given radio signal. Several simple concepts must be understood first, and then we can apply some simple rules of thumb.

The equation for successful radio reception is:

***TX power + TX antenna gain – Path loss – Cabling loss + RX antenna gain – 10dB fade margin > RX Radio sensitivity or (less commonly) RF noise floor***

Note that most of the equation's parameters are easily gleaned from the manufacturer's data. That leaves only path loss and, in cases of heavy RF interference, RF noise floor as the two parameters that you must establish for your particular installation.

In a perfect world, you will measure your path loss and your RF noise conditions. For the majority of us that don't, there are rules of thumb to follow to help ensure a reliable radio connection.

## D.7 RF ATTENUATION AND LINE OF SIGHT

In a clear path through the air, radio signals attenuate with the square of distance. Doubling range requires a four-fold increase in power, therefore:

Halving the distance decreases path loss by 6dB.

Doubling the distance increases path loss by 6dB.

When indoors, paths tend to be more complex, so use a more aggressive rule of thumb, as follows:

Halving the distance decreases path loss by 9dB.

Doubling the distance increases path loss by 9dB.

Radio manufacturers advertise “line of sight” range figures. Line of sight means that, from antenna A, you can see antenna B. Being able to see the building that antenna B is in does not count as line of sight. For every obstacle in the path, de-rate the “line of sight” figure specified for each obstacle in the path. The type of obstacle, the location of the obstacle, and the number of obstacles will all play a role in path loss.

Visualize the connection between antennas, picturing lines radiating in an elliptical path between the antennas in the shape of a football. Directly in the center of the two antennas the RF path is wide with many pathways. A single obstacle here will have minimal impact on path loss. As you approach each antenna, the meaningful RF field is concentrated on the antenna itself. Obstructions located close to the antennas cause dramatic path loss.

Be sure you know the distance between antennas. This is often underestimated. If it is a short-range application, pace it off. If it is a long-range application, establish the actual distance with a GPS or Google Maps.

The most effective way to reduce path loss is to elevate the antennas. At approximately 6 feet high (2 m), line of sight due to the Earth’s curvature is about 3 miles (5 km), so anything taller than a well-manicured lawn becomes an obstacle.

Weather conditions also play a large role. Increased moisture in the air increases path loss. The higher the frequency is, the higher the path loss.

Beware leafy greens. While a few saplings mid-path are tolerable, it’s very difficult for RF to penetrate significant woodlands. If you’re crossing a wooded area you must elevate your antennas over the treetops.

Industrial installations often include many reflective obstacles leading to numerous paths between the antennas. The received signal is the vector sum of each of these paths. Depending on the phase of each signal, they can be added or subtracted. In multiple path environments, simply moving the antenna slightly can significantly change the signal strength.

Some obstacles are mobile. More than one wireless application has been stymied by temporary obstacles such as a stack of containers, a parked truck or material handling equipment. Remember, metal is not your friend. An antenna will not transmit out from inside a metal box or through a storage tank.

**D.8 PATH LOSS RULE OF THUMB**

To ensure basic fade margin **in a perfect line of sight application, never exceed 50% of the manufacturer’s rated line of sight distance.** This in itself yields a theoretical 6dB fade margin – still short of the required 10dB.

De-rate more aggressively if you have obstacles between the two antennas, but not near the antennas. **De-rate to 10% of the manufacture’s line of sight ratings if you have multiple obstacles, obstacles located near the antennas, or the antennas are located indoors.**

**D.9 ANTENNAS**

Antennas increase the effective power by focusing the radiated energy in the desired direction. Using the correct antenna not only focuses power into the desired area but it also reduces the amount of power broadcast into areas where it is *not* needed.

Wireless applications have exploded in popularity with everyone seeking out the highest convenient point to mount their antenna. It’s not uncommon to arrive at a job site to find other antennas sprouting from your installation point. Assuming these systems are spread spectrum and potentially in other ISM or licensed frequency bands, you still want to maximize the distance from the antennas as much as possible. Most antennas broadcast in a horizontal pattern, so vertical separation is more meaningful than horizontal separation. Try to separate antennas with like-polarization by a minimum of two wavelengths, which is about 26 inches (0.66 m) at 900 MHz, or 10 inches (0.25 m) at 2.4 GHz.

**D.10 CABLE LOSS**

Those high frequencies you are piping to your antennas don’t propagate particularly well through cable and connectors. Use high quality RF cable between the antenna connector and your antenna and ensure that all connectors are high quality and carefully installed. Factor in a 0.2 dB loss per coaxial connector in addition to the cable attenuation itself. Typical attenuation figures for two popular cable types are listed below.

Frequency	Cable Types	
	RG-58U*	LMR-400*
900 MHz	1.6 dB	0.4 dB
2.4 GHz	2.8 dB	0.7 dB

*\*Loss per 10 feet (3 meters) of cable length*

While long cable runs to an antenna create signal loss, the benefit of elevating the antenna another 25 feet (7.6 m) can more than compensate for those lost dB.

**D.11 LATENCY AND PACKETIZATION**

Before you lift a finger towards the perfect wireless installation, think about the impact of wireless communications on your application. Acceptable bit error rates are many orders of magnitude higher than wired communications. Most radios quietly handle error detection and retries for you - at the expense of throughput and variable latencies.

Software must be well designed and communication protocols must be tolerant of variable latencies. Not every protocol can tolerate simply replacing wires with radios. Protocols sensitive to inter-byte delays may require special attention or specific protocol support from the radio. Do your homework up front to confirm that your software won’t choke, that the intended radio is friendly towards your protocol, and that your application software can handle it as well.