

WebView-66SN

5.7" Web-enabled HMI

NEW

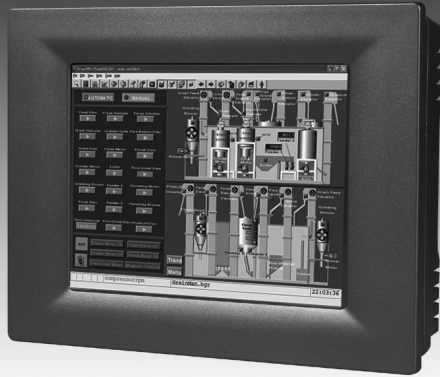

Features

- Intel® XScale PXA processor on board
- 5.7" QVGA color STN LCD
- Super slim and compact design with plastic housing
- Fanless cooling system
- NEMA4/IP65 compliant front panel
- Built-in Windows® CE with Advantech WinCE WebAccess
- One CompactFlash® slot
- Supports Vector-based graphics
- Supports 2 Web Client
- Remote control and monitor by Ordinary IE Browser
- 50 tags real time trend and historical trend
- Supports calendar scheduler
- Import BMP, JPEG, GIF, ACAD DXF

Introduction

Advantech's WebView-66SN is a web-based human-machine interface (HMI) and supervisory control and data acquisition (SCADA) platform. All the features are available in an ordinary Web browser including Animated Graphics Displays, Real-time Data, Controllers, Trends, Alarms and Logs, Scheduler, and more.

Specifications

General

- **Certifications** BSMI, CCC, CE, FCC, UL
- **Cooling System** Fanless design
- **Dimensions (W x H x D)** 195 x 148 x 44.4 mm (7.68" x 5.83" x 1.75")
- **Enclosure** ABS
- **Mounting** Panel Mount
- **OS Support** Windows CE 5.0/4.2
- **Power Consumption** 12 W (typical)
- **Power Input** 18 ~ 32 V_{DC}
- **Watchdog Timer** Programmable as 250 ms, 500 ms, 1 second
- **Weight (Net)** 0.8 kg (1.76 lb)

System Hardware

- **CPU** Intel XScale PXA270 416 MHz
- **Expansion Slots** 1 x CompactFlash slot
- **LAN** 1 x 10/100Base-T
- **Memory** 64 MB SDRAM on board
- **Serial Ports** 2 x full RS-232
1 x 4-pin RS-232/485
- **Storage** 64 MB Flash memory on board
- **USB Ports** 2 x USB 1.1 (one host, one client)

LCD Display

- **Display Type** QVGA CSTN LCD
- **Display Size** 5.7"
- **Max. Resolution** 320 x 240
- **Max. Colors** 64 K
- **Luminance cd/m²** 400
- **Viewing Angle (H/V°)** 100/55
- **Backlight Life** 60,000 hrs
- **Contrast Ratio** 55 : 1

Touchscreen

- **Lifespan** 10 millions times with a silicone rubber of 8 mm diameter finger
- **Light Transmission** Above 75%
- **Resolution** Linearity
- **Type** 4-wire, analog resistive

Environment

- **Humidity** 10 ~ 95% RH @ 40° C, non-condensing
- **Ingress Protection** Front panel: NEMA4, IP65
- **Operating Temperature** 0 ~ 50° C (32 ~ 122° F)
- **Storage Temperature** -20 ~ 60° C (-4 ~ 140° F)

Vibration Protection 1 Grms (Random, Operating)

Software Specifications

- **Operating System** Windows CE

Advantech WinCE WebAccess specifications:

- **I/O Tag Number** 150/600
- **Internal Tag Number** 150/600
- **Web Client** 2
- **Alarm Logging** 1000
- **Action Logging** 1000
- **Message Characters** 50

Graphics

- **# of Graphic Pages** 100
- **Macro Key** Yes Local
- **Script** Yes Variable
- **Per Graphic Page** 255

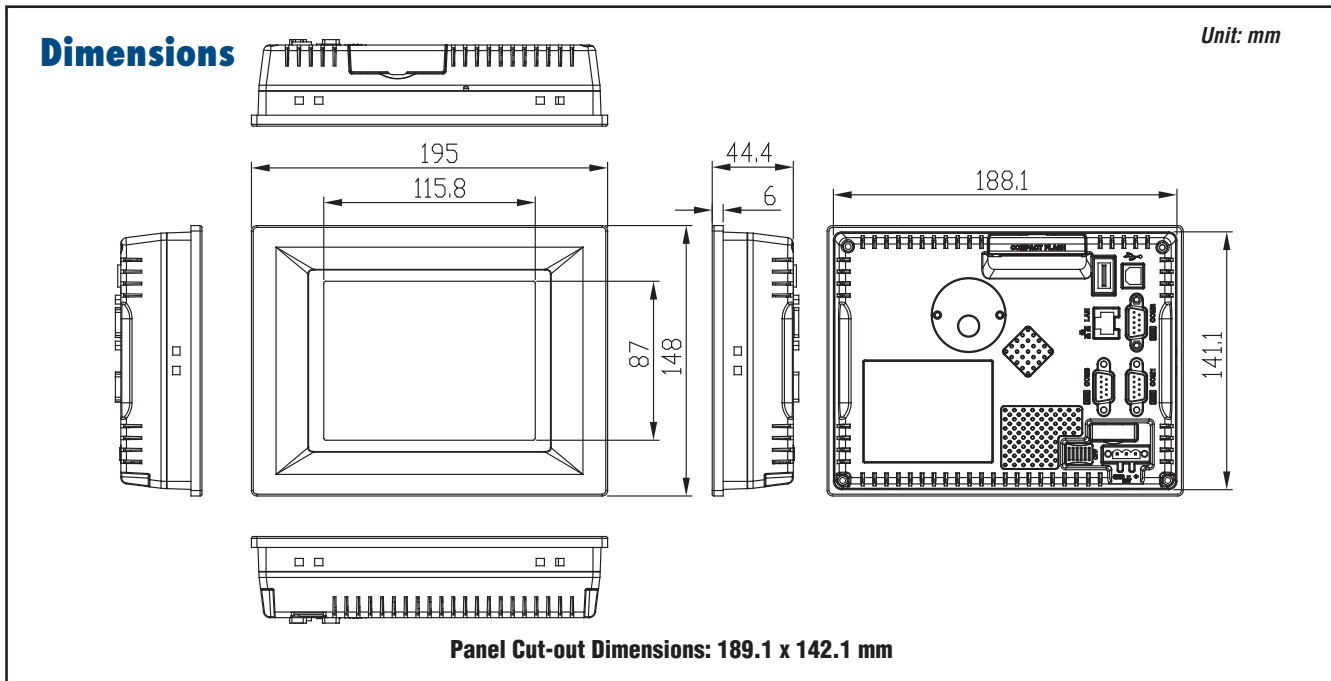

WebAccess Specifications (cont.)

Data Trend Log

- # of data logging 50 Tags

Recipe

- Recipes per Project 100
- Unit per Recipe 100
- Item per Unit 999

Scheduler

- Holiday Configuration 10 groups
- Time Zone Group 99
- Device Loop Group 99
- Equipment Group 99

Ordering Information

- WView66SN-150-W50E** 5.7" Web-enable HMI with WinCE WebAccess150 tags
- WView66SN-600-W50E** 5.7" Web-enable HMI with WinCE WebAccess600 tags

Rear View

