

User Manual

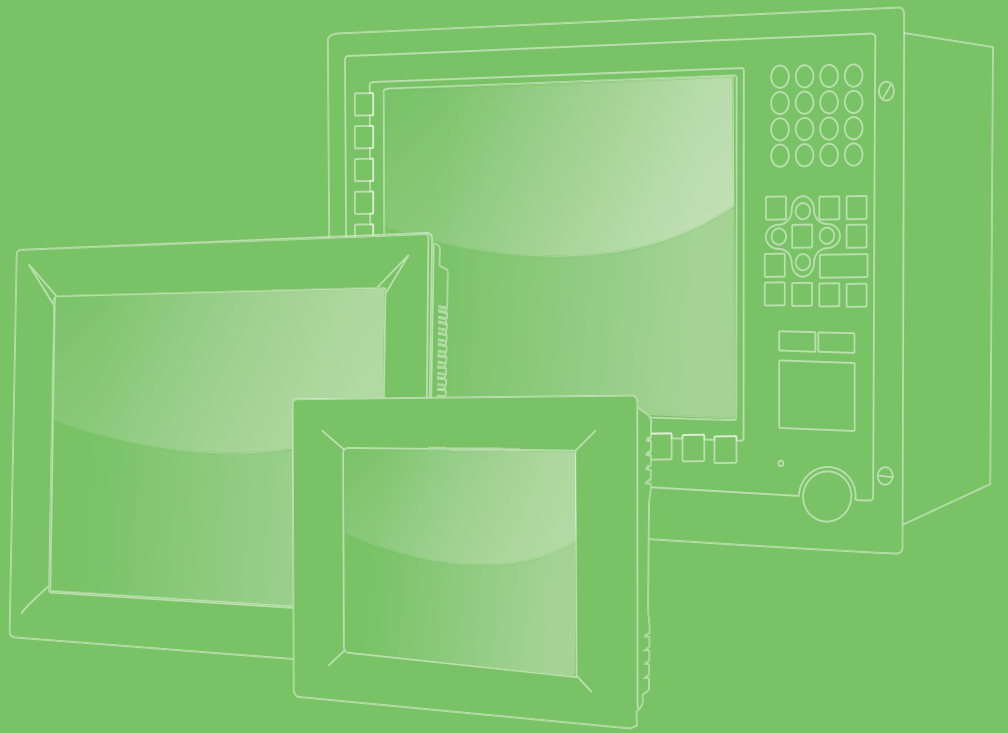

UNO-4671A

Intel® Atom™ D510 1.66GHz
Automation Computer with 6 x
LAN, 10 x COM, 1 x PCI-104

ADVANTECH

Enabling an Intelligent Planet

Copyright

The documentation and the software included with this product are copyrighted 2012 by Advantech Co., Ltd. All rights are reserved. Advantech Co., Ltd. reserves the right to make improvements in the products described in this manual at any time without notice. No part of this manual may be reproduced, copied, translated or transmitted in any form or by any means without the prior written permission of Advantech Co., Ltd. Information provided in this manual is intended to be accurate and reliable. However, Advantech Co., Ltd. assumes no responsibility for its use, nor for any infringements of the rights of third parties, which may result from its use.

Acknowledgements

Intel and Pentium are trademarks of Intel Corporation.

Microsoft Windows and MS-DOS are registered trademarks of Microsoft Corp.

All other product names or trademarks are properties of their respective owners.

Support

For more information on this and other Advantech products, please visit our websites at: <http://www.advantech.com>

For technical support and service, please visit our support website at: <http://www.advantech.com/support/>

This manual is for UNO-4671A.

Product Warranty (2 years)

Advantech warrants to you, the original purchaser, that each of its products will be free from defects in materials and workmanship for two years from the date of purchase.

This warranty does not apply to any products which have been repaired or altered by persons other than repair personnel authorized by Advantech, or which have been subject to misuse, abuse, accident or improper installation. Advantech assumes no liability under the terms of this warranty as a consequence of such events.

Because of Advantech's high quality-control standards and rigorous testing, most of our customers never need to use our repair service. If an Advantech product is defective, it will be repaired or replaced at no charge during the warranty period. For out-of-warranty repairs, you will be billed according to the cost of replacement materials, service time and freight. Please consult your dealer for more details.

If you think you have a defective product, follow these steps:

1. Collect all the information about the problem encountered. (For example, CPU speed, Advantech products used, other hardware and software used, etc.) Note anything abnormal and list any onscreen messages you get when the problem occurs.
2. Call your dealer and describe the problem. Please have your manual, product, and any helpful information readily available.
3. If your product is diagnosed as defective, obtain an RMA (return merchandise authorization) number from your dealer. This allows us to process your return more quickly.
4. Carefully pack the defective product, a fully-completed Repair and Replacement Order Card and a photocopy proof of purchase date (such as your sales receipt) in a shippable container. A product returned without proof of the purchase date is not eligible for warranty service.
5. Write the RMA number visibly on the outside of the package and ship it prepaid to your dealer.

Declaration of Conformity

CE

This product has passed the CE test for environmental specifications. Test conditions for passing included the equipment being operated within an industrial enclosure. In order to protect the product from being damaged by ESD (Electrostatic Discharge) and EMI leakage, we strongly recommend the use of CE-compliant industrial enclosure products.

FCC Class A

Note: This equipment has been tested and found to comply with the limits for a Class A digital device, pursuant to part 15 of the FCC Rules. These limits are designed to provide reasonable protection against harmful interference when the equipment is operated in a commercial environment. This equipment generates, uses, and can radiate radio frequency energy and, if not installed and used in accordance with the instruction manual, may cause harmful interference to radio communications. Operation of this equipment in a residential area is likely to cause harmful interference in which case the user will be required to correct the interference at his own expense.

Technical Support and Assistance

1. Visit the Advantech web site at www.advantech.com/support where you can find the latest information about the product.
2. Contact your distributor, sales representative, or Advantech's customer service center for technical support if you need additional assistance. Please have the following information ready before you call:
 - Product name and serial number
 - Description of your peripheral attachments
 - Description of your software (operating system, version, application software, etc.)
 - A complete description of the problem
 - The exact wording of any error messages

Safety Instructions

1. Read these safety instructions carefully.
2. Keep this User Manual for later reference.
3. Disconnect this equipment from any AC outlet before cleaning. Use a damp cloth. Do not use liquid or spray detergents for cleaning.
4. For plug-in equipment, the power outlet socket must be located near the equipment and must be easily accessible.
5. Keep this equipment away from humidity.
6. Put this equipment on a reliable surface during installation. Dropping it or letting it fall may cause damage.
7. The openings on the enclosure are for air convection. Protect the equipment from overheating. **DO NOT COVER THE OPENINGS.**
8. Make sure the voltage of the power source is correct before connecting the equipment to the power outlet.
9. Position the power cord so that people cannot step on it. Do not place anything over the power cord.
10. All cautions and warnings on the equipment should be noted.
11. If the equipment is not used for a long time, disconnect it from the power source to avoid damage by transient overvoltage.
12. Never pour any liquid into an opening. This may cause fire or electrical shock.
13. Never open the equipment. For safety reasons, the equipment should be opened only by qualified service personnel.
14. If one of the following situations arises, get the equipment checked by service personnel:
 - The power cord or plug is damaged.
 - Liquid has penetrated into the equipment.
 - The equipment has been exposed to moisture.
 - The equipment does not work well, or you cannot get it to work according to the user's manual.
 - The equipment has been dropped and damaged.
 - The equipment has obvious signs of breakage.
15. **DO NOT LEAVE THIS EQUIPMENT IN AN ENVIRONMENT WHERE THE STORAGE TEMPERATURE MAY GO BELOW -20° C (-4° F) OR ABOVE 60° C (140° F). THIS COULD DAMAGE THE EQUIPMENT. THE EQUIPMENT SHOULD BE IN A CONTROLLED ENVIRONMENT.**
16. **CAUTION: DANGER OF EXPLOSION IF BATTERY IS INCORRECTLY REPLACED. REPLACE ONLY WITH THE SAME OR EQUIVALENT TYPE RECOMMENDED BY THE MANUFACTURER, DISCARD USED BATTERIES ACCORDING TO THE MANUFACTURER'S INSTRUCTIONS.**
17. Due to the sensitive nature of the equipment it must be stored in a restricted access location, only accessible by qualified engineers.
18. When installing this equipment, ensure that the Earth cable is securely attached using a 3.5mm screw.
19. The equipment does not include a power cord and plug.
20. The sound pressure level at the operator's position according to IEC 704-1:1982 is no more than 70 dB (A).

DISCLAIMER: This set of instructions is given according to IEC 704-1. Advantech disclaims all responsibility for the accuracy of any statements contained herein.

Safety Precaution - Static Electricity

Follow these simple precautions to protect yourself from harm and the products from damage.

- To avoid electrical shock, always disconnect the power from your PC chassis before you work on it. Don't touch any components on the CPU card or other cards while the PC is on.
- Disconnect power before making any configuration changes. The sudden rush of power as you connect a jumper or install a card may damage sensitive electronic components.

Contents

Chapter 1	Overview	1
1.1	Introduction	2
1.2	Hardware Specifications:	3
1.2.1	General	3
1.2.2	System Hardware	4
1.2.3	I/O Interface	4
1.2.4	Environment	4
1.3	Safety Precautions	5
1.4	Chassis Dimensions:	6
	Figure 1.1 UNO-4671A Chassis Dimensions	6
1.5	Packing List	7
Chapter 2	Hardware Functionality	9
2.1	Overview	10
	Figure 2.1 UNO-4671A Front Panel	10
	Figure 2.2 UNO-4671A Rear Panel	10
2.2	LED Indicators	10
2.2.1	System Status Indicators:	10
	Table 2.1: Definition of System Status Indicators	10
2.2.2	LAN Status Indicators	11
	Table 2.2: Definition of LAN Status Indicators	11
2.2.3	Serial Communication Status Indicators	11
	Table 2.3: Definition of Serial COM Status Indicators	11
2.3	Power Input	12
	Table 2.4: Power Input	12
	Table 2.5: AC/DC Power Input Function Introduction	12
	Figure 2.3 Power1&2 input location(CN1)	13
2.4	RS-232 Interface (COM1,COM2)	13
	Table 2.6: IRQ and I/O Address for COM1,COM2	13
2.5	RS-422/485 Interface (COM3~COM6)	13
2.5.1	OXuPCI954 UARTs with 128 bytes FIFO	13
2.5.2	RS-422/485 Detection	13
2.5.3	Automatic Data Flow Control Function for RS-485	14
2.5.4	Terminal Resistor	14
	Table 2.7: Jumper setting of terminal resistor	14
	Table 2.8: Mapping table of Jumper/DIP for COM(3~6) port	14
	Figure 2.4 COM3~6 Port Related Jumper/Switch Locations	15
2.5.5	RS-485 Auto Flow & RS-422 Master/Slave Modes	15
	Table 2.9: SW2 DIP Setting	15
2.6	RS-485 Interface (COM7~COM10)	15
2.6.1	Terminal Resistor	16
	Table 2.10: Jumper setting of terminal resistor	16
	Table 2.11: Mapping table of Jumper/DIP for COM(7~10) port	16
	Figure 2.5 COM7~10 Port Related Jumper/Switch Locations	16
2.7	LAN: Ethernet Connector	17
2.8	USB Ports	17
2.9	VGA Display	17
2.10	Advanced Watchdog Timer	17
2.11	PCI-104	17
	Figure 2.6 PCI-104(CN14) Location	18

Chapter	3	Initial Setup.....	19
3.1		Configuration.....	20
3.2		Install a CompactFlash Card.....	21
		Figure 3.1 CompactFlash Card Slot Location.....	21
3.3		Installing a USB Dongle	22
		Figure 3.2 CN7 Location of Internal USB Port.....	22
3.4		Installing a Hard Disk	23
		Figure 3.3 SATA Signal and Power Connector Location.....	24
3.5		Installation on Rack.....	24
3.6		BIOS Setup and System Assignments	25
Appendix A		System Settings & Pin Assignments	
		27
A.1		RS-232/422/485 Serial Ports (COM1~COM10).....	28
		Table A.1: COM1~2 Port Pin Definitions	28
		Table A.2: RS-422/485 Serial Ports (COM3~10).....	28
A.2		USB Connectors (USB1~USB2).....	29
		Table A.3: USB Connector Pin Assignments.....	29
A.3		VGA Display Connector	29
		Table A.4: VGA Adaptor Cable Pin Assignments	29
Appendix B		Watchdog Timer Programming	31
B.1		Watchdog Timer Programming	32

Chapter 1

Overview

This chapter provides an overview of UNO-4671A's specifications.

Sections include:

- Introduction
- Hardware Specifications
- Safety Precautions
- Chassis Dimensions
- Packing List

1.1 Introduction

UNO-4671A is an embedded Application Ready Platform (ARP) that can shorten development time and offers rich networking interfaces to fulfill extensive needs. UNO-4671A is designed to be a total solution for network enabled Application Ready Platforms.

Leveraging field-approved and worldwide approved real-time OS technology, Advantech UNO-4671A provides WES 2009, Windows XP, Windows CE 6.0 and Linux ready solution, and supports several standard networking interfaces, such as Ethernet, RS-232/422/485 and more.

Because of its openness, great expansion capability and reliable design (dual power fanless and diskless), the UNO-4671A is ideal embedded platform for implementing customer's software for diverse applications.

Target on Data Server and Communication Gateway in Substations

Advantech UNO-4671A has been defined and designed to be compliant with IEC-61850-3, which has been defined as an international hardware standard of communication network and system in power substations. In modern power substation, this standard facilitates the management to large number of devices and enables the various devices to communicate with one another. UNO-46721A is a ready and certified platform to serve these requirements.

Open Architecture Designed for Automation

For applications demanding customized control, a UNO-4671A that uses more flexible, off-the-shelf technology is a better option. UNO-4671A uses off-the-shelf components such as an x86 processor, an Ethernet chip set, Compact Flash., and DRAM. At the same time, the UNO-4671A unit can broadcast the process data through the Ethernet and share the data with operators and managers. By using off-the-shelf components, machine builders can customize the control scheme they use for other machines that require multiple inputs, optimized control, or Ethernet communication. So, UNO-4671A offers the I/O connectivity of PCs with options like: 6 x Ethernet (6 x 10/100 Base-T), 10 x Serial ports (2 x RS-232, 4 x RS-422/485 and 4 x RS-485), 4 x USB ports (1 x Front, 2 x Rear, 1 x Internal), 1 x CompactFlash , 1 x SATA and VGA interface for display panels.

Robust IO Isolate System from Electrical Noise

UNO-4671A is designed for the applications in substation where is supposed to have certain electric interference. Equipping with isolated power, isolated communication ports, UNO-4671A has high resistance toward electrical noise. It has been proved not only can work well in substation but also suitable for any harsh applications

An Industry-Proven Design

Industrial applications require controllers with high-vibration specifications and a wide temperature range. Controllers in industrial environments require flexible and stable mounting, and many machine builders underestimate the need for rugged controllers because their applications are mounted in an industrial enclosure. UNO-4671A has a special design without the weaknesses of a standard PC. No fan, and no HDD prevent dust and vibration problems. With a smart mechanical design, UNO-4671A can meet 50 G shock (with CompactFlash), 2 G vibration (with CompactFlash), up to 60° C operating temperature (tested under 100% CPU loading) and almost anything an industrial environments demand.

Designed to Fit Comfortably Into Racks

In completely new packaging, UNO-4671A has standard 2U rack size as 440 x 220 x 88 mm (W x H x D) could fit your rack. The rear IO connection and indicator LEDs on the front panel for all ports and modes highly simplify monitoring for operation and maintenance in the rack. You could easily mount UNO-4671A on rack, manage all UNOs in one rack and easily develop your application on rack.

Flexible Networking Options

The Advantech UNO-4671A offers two ways to connect to a network: Ethernet and Modem. The six built-in Ethernet ports provide high-speed networking capability up to 1 Gbps. And through UNO-4671A's isolated serial COM ports, you could link industrial modems to offer the most popular and easiest networking method by PSTN. UNO-4671A provides 2 channels full 9-pins standard RS-232 isolated serial COM ports, 4 channels isolated serial COM ports with RS-422/485 selectable and 4 channels isolated serial COM ports with RS-485 selectable. These ports all equip with surge and isolation protection up to 2000 VDC, protecting your system from abrupt high voltage attack and accident or damage in harsh environments.

Popular Operating Systems and Rapid Application Development

The Advantech UNO-4671A supports the popular off-the-shelf Microsoft Windows NT/XP operating systems and the Linux operating system. UNO-4671A also features pre-built Microsoft WES 2009, Windows XP, Windows CE 6.0 and Linux solutions offering a pre-configured image with optimized onboard device drivers. Microsoft Windows CE and XP Embedded are compact, highly efficient, and real-time operating systems that are designed for embedded systems without a HDD. There is no need to waste time and energy on developing onboard device drivers or using the Platform Builder to build a custom Windows CE image, they have all been done for the Advantech UNO-4671A series. Through the built-in runtime library and Software Development Kit (SDK), the UNO-4671A series leverages your existing Windows-based programming skills to rapidly develop applications.

1.2 Hardware Specifications:

1.2.1 General

- **Certification:** CE, FCC class A, CCC, Electricity IV level for China (Compatible IEC 61850-3, IEEE 1613)
- **Dimensions (W x D x H):** 2U (440 x 220 x 88 mm/17.3" x 8.6" x 3.4") fits into standard 19 inch rack
- **Enclosure:** SECC
- **Mounting:** 2U Rackmount
- **Power Consumption:** 30 W @ 24 V (Typical)
- **Power Requirements:** Supports dual power input
Power 1: 100 ~ 240 VAC or 100 ~ 240 VDC (Optional 18 ~ 30 VDC)
Power 2: 100 ~ 240 VAC or 100 ~ 240 VDC (Optional 18 ~ 30 VDC)
- **Weight:** < 5.5 kg
- **System Design:** Fanless design
- **OS Support:** WES 2009, Windows XP, Windows CE 6.0 and Linux
- **Remote Management:** Built-in Advantech DiagAnywhere agent on Windows CE/XPe

1.2.2 System Hardware

- **CPU:** Intel Atom D510 1.66 GHz
- **Memory:** 2G DDR2 SDRAM
- **Indicators:** LEDs for Power1&2, IDE, LAN (Active,Link) and Serial (Tx, Rx)
- **Storage:** CF 1 x internal type I/II CompactFlash? slot HDD Built-in one 2.5" SATA HDD bracket
- **Display:** DB15 VGA connector, Intel® Atom™ D510 up to 1920 x 1024
- **PCI-104 Slot:** 1 x PCI-104 supports +3.3 V & +5 V power
- **Reset Button:** Yes
- **WatchDog Timer:** Programmable 256 levels time interval, from 1 to 255 seconds for each tier

1.2.3 I/O Interface

- **Serial Ports:** 2 x DB-9 RS-232
4 x screw terminals with 5-wired RS-422/485
4 x screw terminals with 3-wired RS-485
(Automatic RS-485 data flow control) 2,500 VDC isolation
- **Serial Port Speed:**
(COM1, COM2) RS-232: 50 ~ 115200bps,
(COM3 ~ COM6) RS-422/485: 50 ~ 921600bps
(COM7 ~ COM10) RS-485: 50 ~ 921600bps
- **LAN:** 6 x 10/100 Base-T RJ-45 ports
- **USB Ports:** 4 x USB, UHCI, Rev. 2.0 compliant 1 x Front, 2 x Rear and 1 x Internal ports
- **Extension:** 1 x PCI-104

1.2.4 Environment

- **Humidity:** 95% @ 40°C (non-condensing)
- **Operating Temperature:** IEC 60068-2-2 with 100% CPU/ I/O loading, 48 hrs - 20 ~ 60°C (-4 ~ 140°F)
- **Operating Humidity:** 20 ~ 95% (non-condensing)
- **Shock Protection:** IEC 60068-2-27
 - CompactFlash: 50 G half sine, 11 ms
 - HDD: 20 G half sine, 11 ms
- **Vibration Protection:** IEC 60068-2-64 (Random 1 Oct./min, 1hr/axis.)
 - CompactFlash: 2 Grms @ 5 ~ 500 Hz,
 - HDD: 1 Grms @ 5 ~ 500 Hz

1.3 Safety Precautions

The following messages inform how to make each connection. In most cases, you will simply need to connect a standard cable

Warning! *Always disconnect the power cord from your chassis whenever you are working on it. Do not connect while the power is on. A sudden rush of power can damage sensitive electronic components. Only experienced electronics personnel should open the chassis.*



Caution! *Always ground yourself to remove any static electric charge before touching UNO-4671A. Modern electronic devices are very sensitive to static electric charges. Use a grounding wrist strap at all times. Place all electronic components on a static-dissipative surface or in a static-shielded bag*



Note! *If DC voltage is supplied by an external circuit, please put a protection device in the power supply input port.*



1.4 Chassis Dimensions:

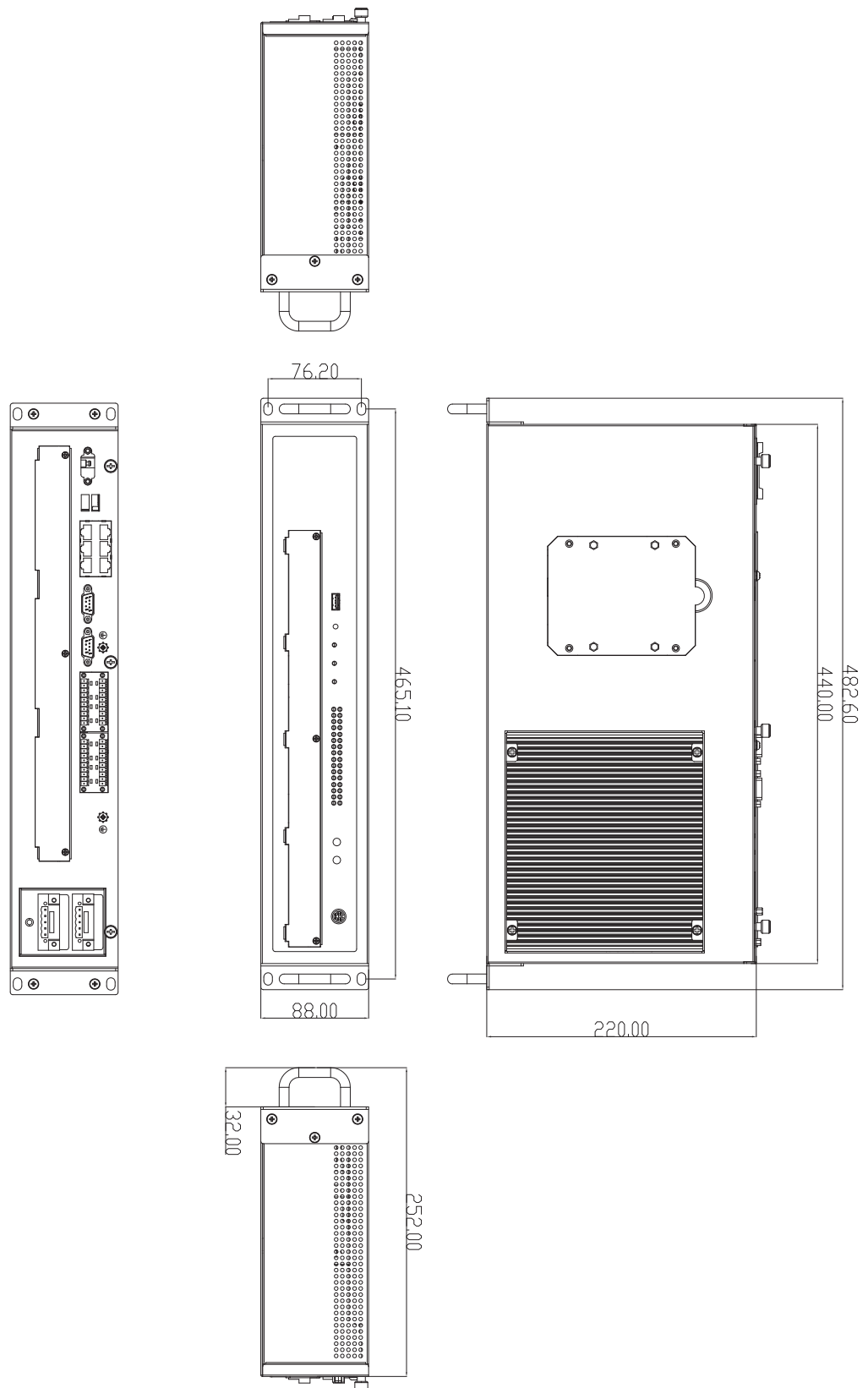

Figure 1.1 UNO-4671A Chassis Dimensions

1.5 Packing List

The accessory package of UNO-4671A contains the following items:

- (A) UNO-4671A
- (B) 2 x rack mounting kit
- (C) M4x8 10 pcs screw for rack mount kit
- (D) 2 x front handles
- (E) M3x6 6 pcs screws for SATA HDD installation
- (F) 4 x 10-pins green screw terminals
- (G) 1 x SATA signal cable
- (H) 1 x SATA power cable
- (I) 16 pcs jumper shorter
- (J) 1 x S-CH manual
- (K) 1 x ROHS LIST
- (L) UNO series Driver and Utility DISC
- (M) 1 x warranty card
- (N) 1 x clamp for USB dongle
- (O) 2 x screws for USB clamp

Chapter 2

Hardware Functionality

This chapter shows how to setup the UNO-4671A's hardware functions, including connecting peripherals, setting switches and indicators.

Sections include:

- Overview
- LED Indicators
- Power Input
- RS-232 Interface
- RS-422/485 Interface
- RS-485 Interface
- LAN / Ethernet Connector
- USB Ports
- VGA Display
- Advanced Watchdog Timer
- PCI-104

2.1 Overview

The following two figures show the indicators and connectors on UNO-4671A. The following sections give you detailed information about function of each peripheral.



Figure 2.1 UNO-4671A Front Panel



Figure 2.2 UNO-4671A Rear Panel

2.2 LED Indicators

The LEDs in the front panel can be divided into 3 groups



2.2.1 System Status Indicators:



Table 2.1: Definition of System Status Indicators

Item	LED	Status	Description
1	PWR1	Green	System power1 is on
		Off	System power1 is off
2	PWR2	Green	System power2 is on
		Off	System power2 is off
3	IDE	Green	Data being received/ transmitted between storage devices
		Off	No Data being received/ transmitted between storage devices

2.2.2 LAN Status Indicators

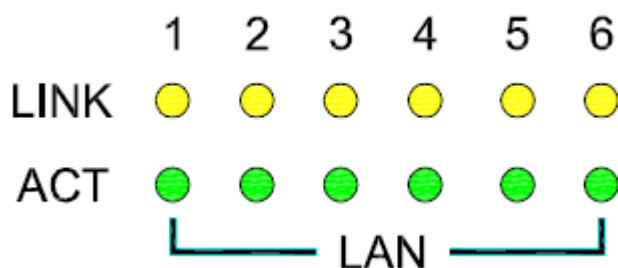

Table 2.2: Definition of LAN Status Indicators

Item	LED	Status	Description
1	LAN/ LINK Port 1~6	Orange	100Mbps network link
		Off	10Mbps network link or invalid network link
2	LAN/ ACT Port 1~6	Green	Ethernet data being received/ transmitted
		Off	No Ethernet data being received/ transmitted

2.2.3 Serial Communication Status Indicators

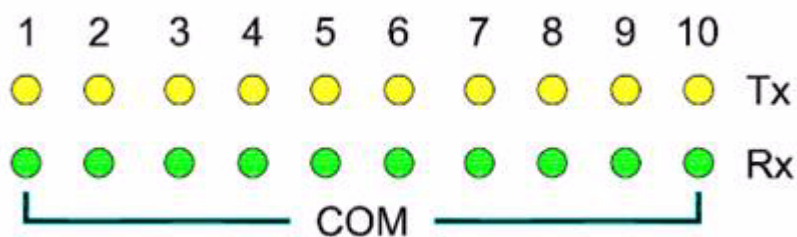

Table 2.3: Definition of Serial COM Status Indicators

Item	LED	Status	Description
1	COM/Rx Port 1 ~ 10	Green	Serial port data being received
		Off	No data being received
2	COM/Tx Port 1 ~ 10	Orange	Serial port data being transmitted
		Off	No data being transmitted

2.3 Power Input

The UNO-4671A support dual power input AC or DC power input to fulfill the need of field site. Following table shows the specification of the power input.

Table 2.4: Power Input

Item	AC/DC	Volt. Range	Power Rating	Connector Type
PWR1	AC	100-240 V	0.6Amax~0.12Amin47-63 Hz	5Pin Screw Terminal
	DC	100-240 V	0.6Amax~0.09Amin	5Pin Screw Terminal
PWR2	AC	100-240 V	0.6Amax~0.12Amin47-63 Hz	5Pin Screw Terminal
	DC	100-240 V	0.6Amax~0.09Amin	5Pin Screw Terminal

The function of each part is described as below:

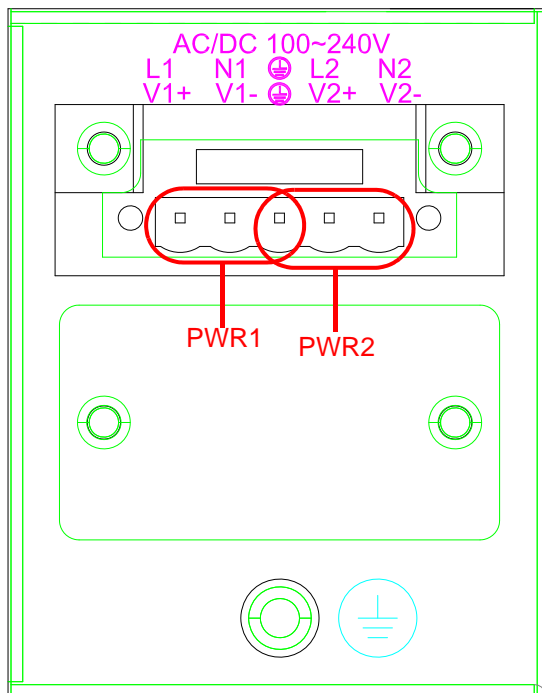

Table 2.5: AC/DC Power Input Function Introduction

Item	Function Description
1	5-pin Screw Terminal PWR1 for AC/DC power input
2	5-pin Screw Terminal PWR2 for AC/DC power input

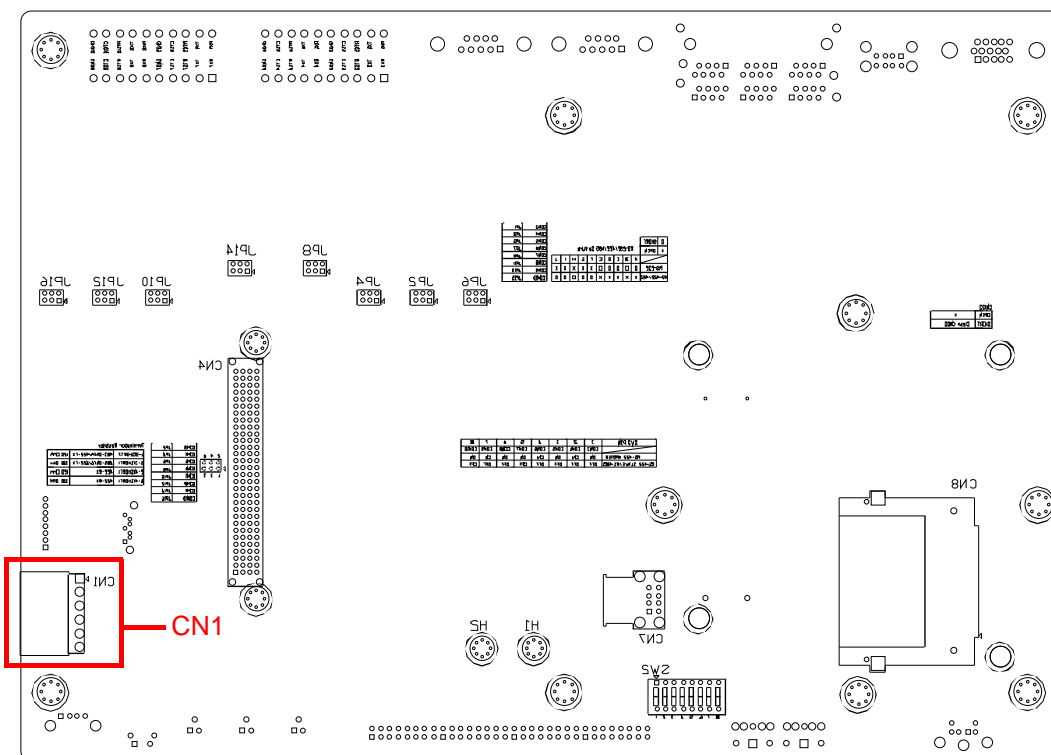

Figure 2.3 Power1&2 input location(CN1)

2.4 RS-232 Interface (COM1,COM2)

The UNO-4671A offers two standard RS-232 serial communication interface port: COM1 and COM2. Please refer to A.1 for pin assignments. The IRQ and I/O address of COM1 and COM2 are listed below:

Table 2.6: IRQ and I/O Address for COM1,COM2

COM No.	IRQ	I/O Address
COM1	IRQ4	3F8H
COM2	IRQ3	2F8H

2.5 RS-422/485 Interface (COM3~COM6)

The UNO-4671A offers four RS-422/485 serial communication interface ports: COM3 to COM6. Please refer to Appendix A.2 for their pin assignments. The default setting of COM3 to COM6 are RS-422/485.

2.5.1 OXuPCI954 UARTs with 128 bytes FIFO

Advantech UNO-4671A comes with Oxford OXuPCI954 UARTs containing 128 bytes FIFO.

2.5.2 RS-422/485 Detection

In RS-422/485 mode, UNO-4671A automatically detects signals to match RS-422 or RS-485 networks. (No jumper change required)

2.5.3 Automatic Data Flow Control Function for RS-485

In RS-485 mode, UNO-4671A automatically detects the direction of incoming data and switches its transmission direction accordingly. So no handshaking signal (e.g. RTS signal) is necessary. This lets you conveniently build an RS-485 network with just two wires.

2.5.4 Terminal Resistor

The onboard termination resistor (120 ohm/300 ohm) for COM3~COM6 can be used for long distance transmission or device matching. (Default Open.) Please also refer to Table 2.8 for the mapping table of Jumper and COM port

Table 2.7: Jumper setting of terminal resistor

JPx	Description
	Add 120 ohm terminal resistor on Tx+/Tx- of RS-422 or Data+/Data- of RS-485
	Add 300 ohm terminal resistor on Tx+/Tx- of RS-422 or Data+/Data- of RS-485
	Add 120 ohm terminal resistor on Rx+/Rx- of RS-422
	Add 300 ohm terminal resistor on Rx+/Rx- of RS-422

Table 2.8: Mapping table of Jumper/DIP for COM(3~6) port

COM port	SW2 DIP switch for Auto-flow control	Jumper for Terminal Resistor
COM3	DIP1	JP2
COM4	DIP2	JP4
COM5	DIP3	JP6
COM6	DIP4	JP8

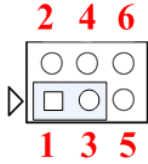
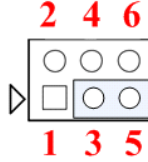
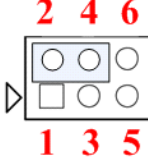
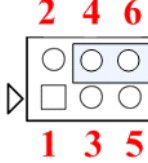
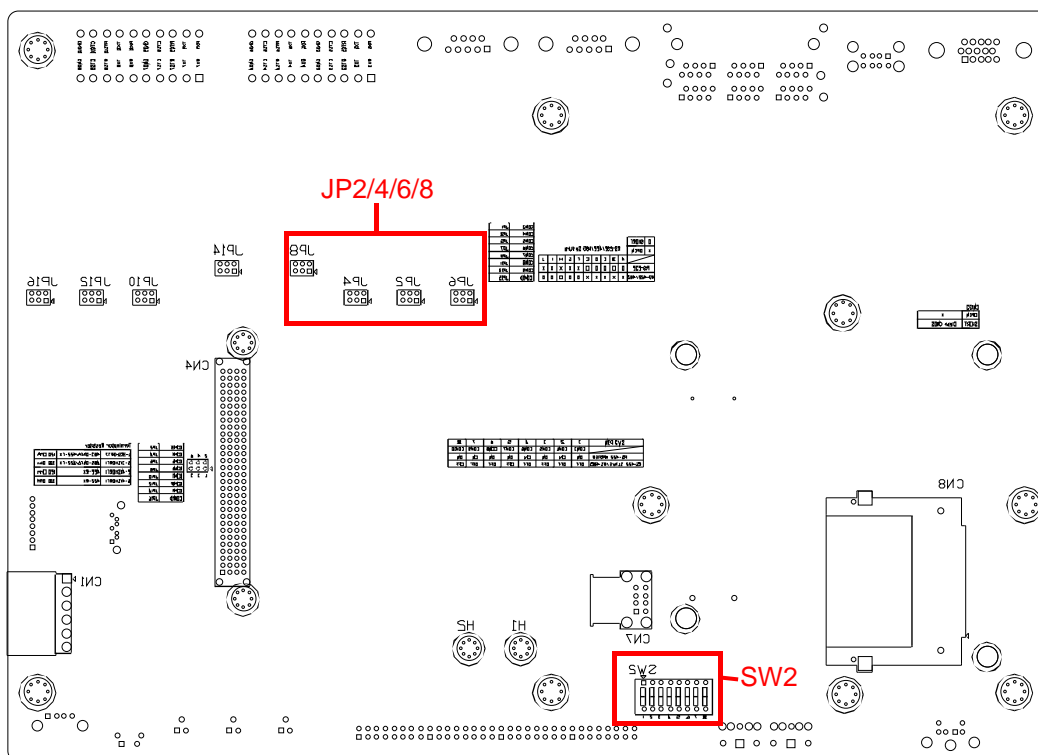

Figure 2.4 COM3~6 Port Related Jumper/Switch Locations

2.5.5 RS-485 Auto Flow & RS-422 Master/Slave Modes

You can set the "Auto Flow Control" mode of RS-485 or "Master/Slave" mode of RS-422 by using the SW2 DIP switch for COM3~COM6. Please also refer to Table 2.9 for the COM port mapping with the DIP.

In RS-485, if the switch is set to "Off", the driver automatically senses the direction of the data flow and switches the direction of transmission. No handshaking is necessary.

In RS-422, if DIP switch is set to "On," the driver is always enabled, and always in high or low status. Please refer below for the default setting.

Table 2.9: SW2 DIP Setting

SW2 Status	Description
ON	RS-422: Master mode RS-485: N/A
OFF(Default)	RS-422: Slave mode RS-485: Auto flow control

2.6 RS-485 Interface (COM7~COM10)

The UNO-4671A offers four RS-485 serial communication interface ports: COM7 to COM10. Please refer to Appendix A.2 for their pin assignments. The default setting of COM7 to COM10 are RS-485.

In RS-485 mode, UNO-4671A automatically detects the direction of incoming data and switches its transmission direction accordingly. So no handshaking signal (e.g. RTS signal) is necessary. This lets you conveniently build an RS-485 network with just two wires.

2.6.1 Terminal Resistor

The onboard termination resistor (120 ohm/300 ohm) for COM7~COM10 can be used for long distance transmission or device matching. (Default Open.) Please also refer to Table 2.11 for the mapping table of Jumper and COM port.

Table 2.10: Jumper setting of terminal resistor

JPx	Description
JP10/ JP12/ JP14/ JP16	 <p>Add 120 ohm terminal resistor on Data+/Data- of RS-485</p>
	 <p>Add 300 ohm terminal resistor on Data+/Data- of RS-485</p>

Table 2.11: Mapping table of Jumper/DIP for COM(7~10) port

COM port	SW2 DIP switch for Auto-flow control	Jumper for Terminal Resistor
COM7	DIP5	JP10
COM8	DIP6	JP12
COM9	DIP7	JP14
COM10	DIP8	JP16

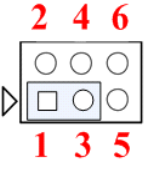
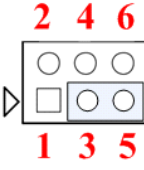
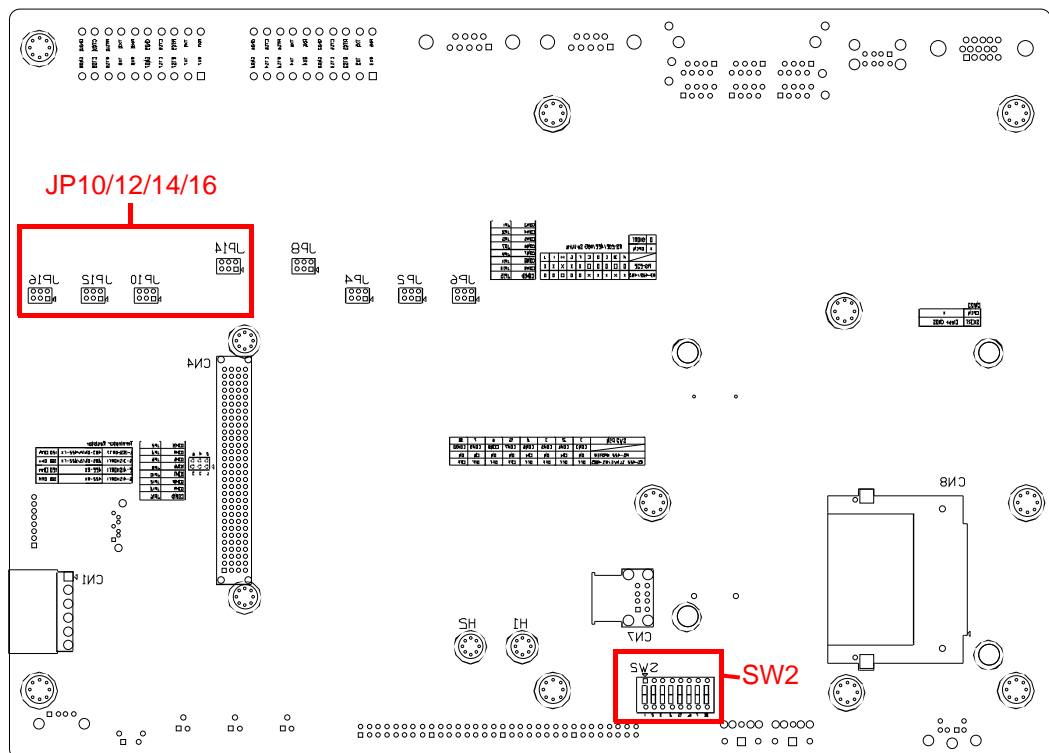

Figure 2.5 COM7~10 Port Related Jumper/Switch Locations

2.7 LAN: Ethernet Connector

The UNO-4671A is equipped with 6 Realteck 10M/100M Ethernet Controller which are compliant with IEEE 802.3u 10/ 100Base-T CSMA/CD standard. The Ethernet port provides a standard RJ-45 jack on board, and LED indicators on the front side to show its Link and Active status. Please note these LAN controllers all use PCI resource, the bandwidth or throughput may be restricted by the PCI bandwidth.

2.8 USB Ports

The UNO-4671A provides four USB interface connectors, which provide complete Plug & Play and hot swapping for up to 127 external devices.

The USB interface complies with USB UHCI, Rev. 2.0 compliant. The USB interface can be disabled in the system BIOS setup. UNO-4671A provides 1 USB port on the front panel, and 2 USB port on

the rear panel. It also provides 1 USB port inside the chassis for USB dongle key.

2.9 VGA Display

The UNO-4671A with Intel ICH8-M, integrates the graphic controller GMA-3150 and provides a resolution of 1920 x 1024 for VGA output

2.10 Advanced Watchdog Timer

The UNO-4671A provides one hardware Watchdog Timer for users to have a chance to escalate system status before the forced system reset. Users can operate system I/O port 4E and 4F to set different time. You can see Interface technique of Micro-computer or example by Advantech(Appendix B).

2.11 PCI-104

UNO-4671A supports standard PCI-104 version 1.2 expansion, which supports up to 2 PCI device. You also could install the expansion of other functions of the PCI-104 interface to meet customer's demand. The power supply is 3.3V default.

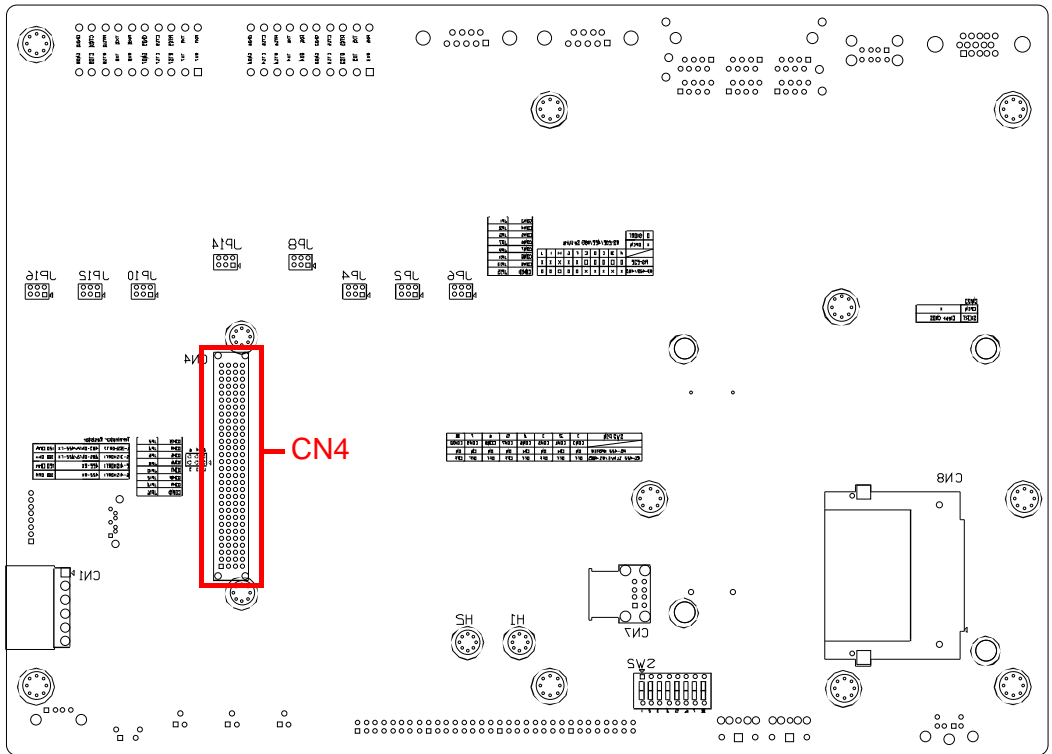

Figure 2.6 PCI-104(CN14) Location

Chapter 3

Initial Setup

3.1 Configuration

To open the chassis, please follow the steps below:

1. Remove all power and signal connections
2. Place the unit heat-sink side down
3. Remove the screws shown below

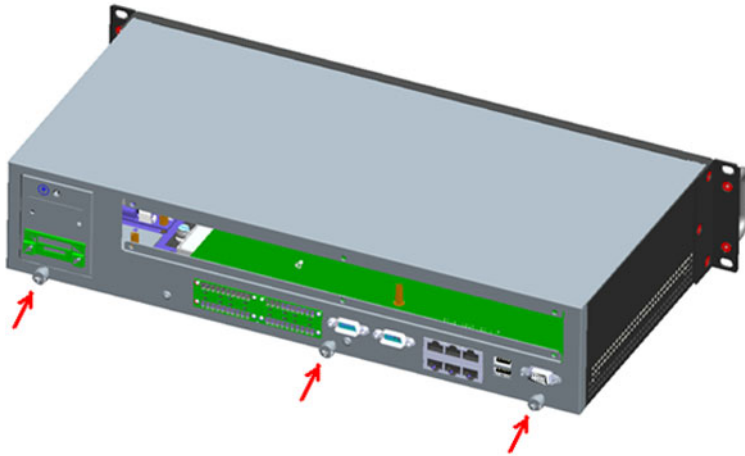

4. Remove the L-shaped cover

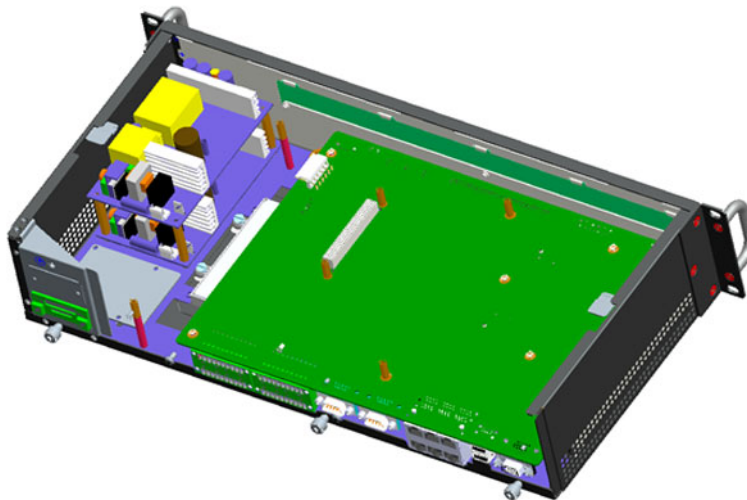

Note! *If an HDD is installed, please remove any HDD related connections before opening the chassis.*



3.2 Install a CompactFlash Card

UNO-4671A provides 1 CompactFlash Card slots, to install the cards:

1. Please follow 3.1 to open the chassis.
2. Insert the card at the location (CN8) shown below.

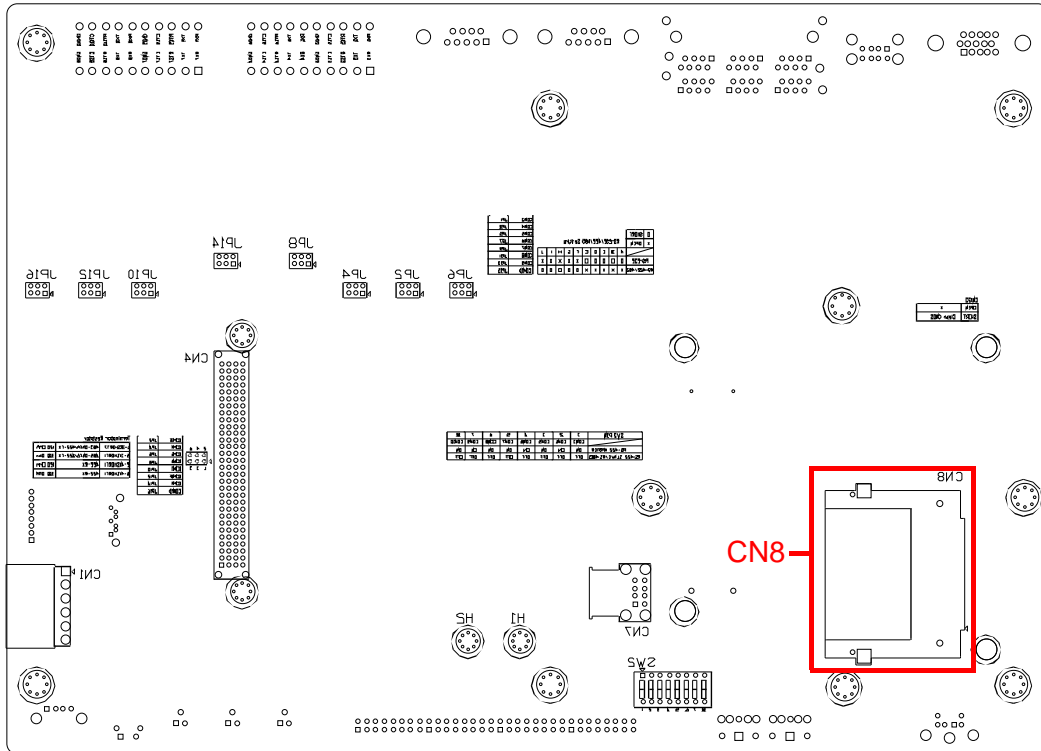
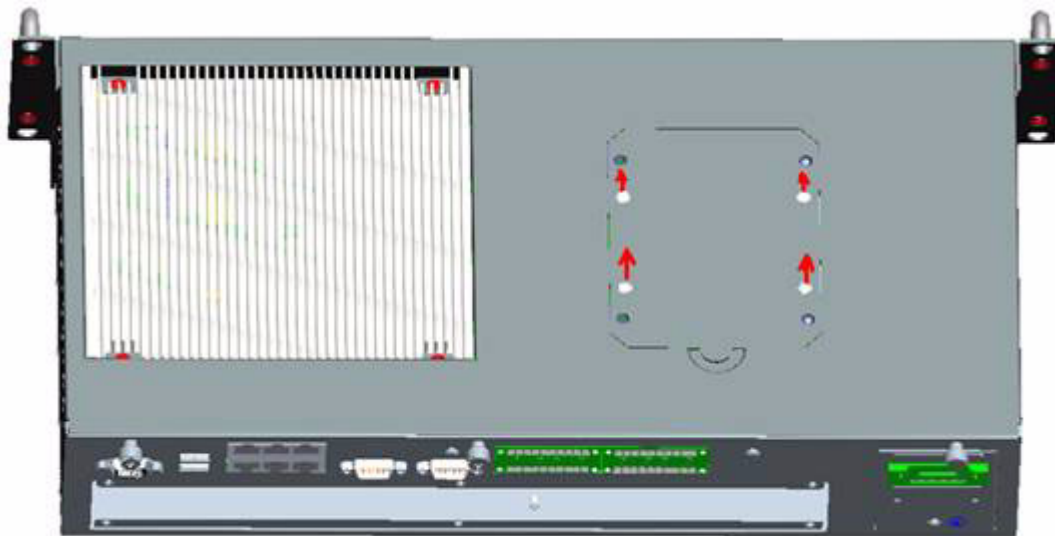

Figure 3.1 CompactFlash Card Slot Location

3.4 Installing a Hard Disk

Please follow the steps below to install an HDD:

1. Turn the unit heat-sink side down.
2. Unscrew the 4 screws and remove the HDD bay.



3. Insert the HDD into the HDD bay and screw it.

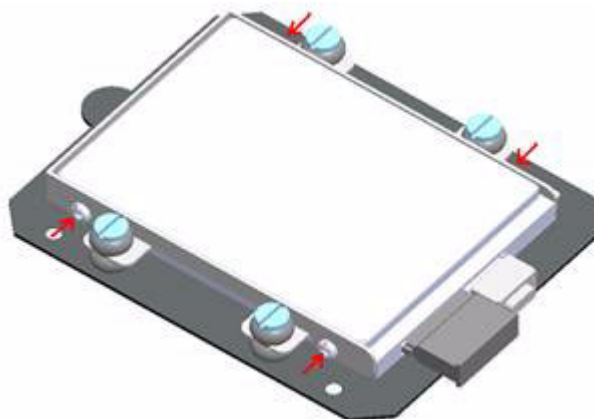

4. Connect the SATA cable between HDD and connector then assemble the HDD back to the chassis. The locations of the connectors are shown below, SATA signal connector locates on CN21 and SATA power connector locates on CN11.

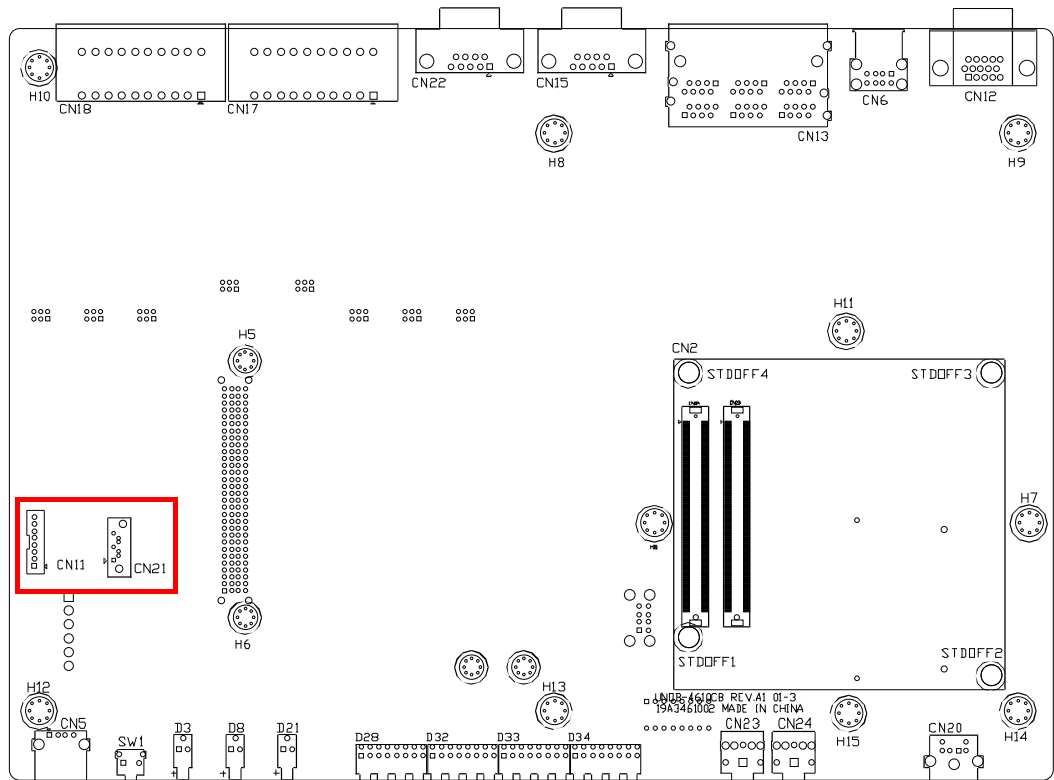
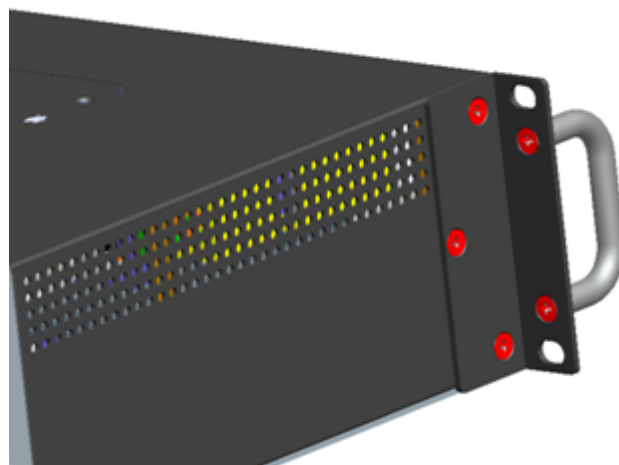

Figure 3.3 SATA Signal and Power Connector Location

3.5 Installation on Rack

UNO-4671A provides the kits for Rack mounting in the accessory box.

1. Please screw the ears and handles at the position indicated below. The same on the other side.



2. Use the 4 screw holes to mount the UNO-4671A on the rack.



3. UNO-4671A equips the Aluminum Fins on the top of the unit as heat-sink. It can generate nature convection for better heat transmission. To have optimal thermal performance, please leave 2U (440 mm) space height on the top of the unit

3.6 BIOS Setup and System Assignments

UNO-4671A adopts Advantech's SOM-6763 CPU module. Further information about the SOM module, can be found in SOM Board User Manual. You can find this manual on the UNO-4671A's companion DISC.

Please note that you can try to "LOAD BIOS DEFAULTS" from the BIOS Setup manual if the UNO-4671A does not work properly.

Note! UNO-4671A does not support S3(Suspend to RAM) mode.



Appendix **A**

System Settings & Pin
Assignments

A.1 RS-232/422/485 Serial Ports (COM1~COM10)

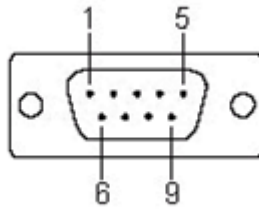

Table A.1: COM1~2 Port Pin Definitions

PIN	RS-232
1	DCD
2	RxD
3	TxD
4	DTR
5	GND
6	DSR
7	RTS
8	CTS
9	RI

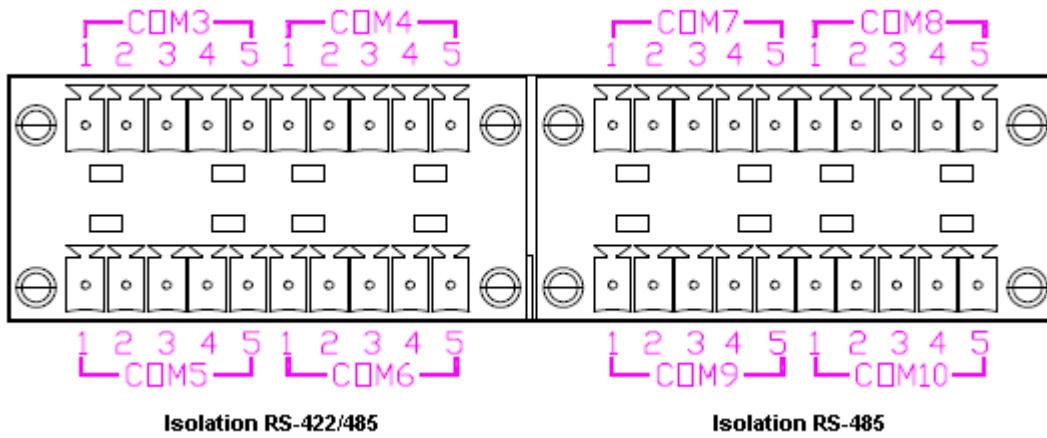

Table A.2: RS-422/485 Serial Ports (COM3~10)

Pins	RS-422/485	RS-485
1	Tx+	Data+
2	Tx-	Data-
3	Rx+	-
4	Rx-	-
5	GND	GND

A.2 USB Connectors (USB1~USB2)

Table A.3: USB Connector Pin Assignments

Pin	Signal	Cable Color
1	VCC	Red
2	DATA-	White
3	DATA+	Green
4	GND	Black

A.3 VGA Display Connector

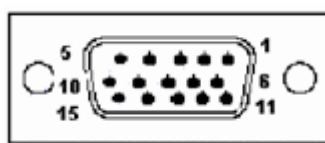

Table A.4: VGA Adaptor Cable Pin Assignments

Pin	Signal
1	RED
2	GREEN
3	BLUE
4	N/C
5	GND
6	GND
7	GND
8	GND
9	VCC
10	GND
11	N/C
12	VGA_SDA
13	HSYNC
14	VSYNC
15	VGA_SCL

Appendix **B**

Watchdog Timer Programming

B.1 Watchdog Timer Programming

 Enter the extended function mode, interruptible double-write

```
MOV DX,4EH
MOV AL,87H
OUT DX,AL
OUT DX,AL
```

 Configured logical device 8, configuration register CRF6

```
MOV DX,4EH
MOV AL,2BH
OUT DX,AL
MOV DX,4FH
IN AL,DX
AND AL,0EFH;Setbit 4=0 Pin 89=WDTO
OUT DX,AL
MOV DX,4EH
MOV AL,07H; point to Logical Device Number Reg.
OUT DX,AL
MOV DX,4FH
MOV AL,08H; select logical device 8
OUT DX,AL;
MOV DX,4EH
MOV AL,30H;Set watch dog activate or inactivate
OUT DX,AL
MOV DX,4FH
MOV AL,01H; 01:activate 00:inactivate
OUT DX,AL;
MOV DX,4EH
MOV AL,F5H; Setting counter unit is second
OUT DX,AL
MOV DX,4FH
MOV AL,00H
OUT DX,AL;
MOV DX,4EH
MOV AL,F6H
OUT DX,AL
MOV DX,4FH
MOV AL,05H; Set 5 seconds
OUT DX,AL
;-----
; Exit extended function mode
;-----
```



```
MOV DX,4EH  
MOV AL,AAH  
OUT DX,AL
```

www.advantech.com

Please verify specifications before quoting. This guide is intended for reference purposes only.

All product specifications are subject to change without notice.

No part of this publication may be reproduced in any form or by any means, electronic, photocopying, recording or otherwise, without prior written permission of the publisher.

All brand and product names are trademarks or registered trademarks of their respective companies.

© Advantech Co., Ltd. 2012