

User's Manual

RS-400-SF

4U Server

Copyright Notice

This document is copyrighted, 2002, by Advantech Co., Ltd. All rights are reserved. Advantech Co., Ltd. reserves the right to make improvements to the products described in this manual at any time without notice.

No part of this manual may be reproduced, copied, translated or transmitted in any form or by any means without the prior written permission of the original manufacturer. Information provided in this manual is intended to be accurate and reliable. However, the original manufacturer assumes no responsibility for its use, nor for any infringements upon the rights of third parties that may result from its use.

CE Notification

RS-400-SF and RS-400-SF-S4, developed by Advantech Co., Ltd., have passed the CE test for environment specifications when shielded cables are used for external wiring. We recommend the use of shielded cables.

Acknowledgements

- AWARD is a trademark of AWARD Software, Inc.
- IBM and PC are trademarks of International Business Machines Corporation
- Intel Pentium 4 is trademarks of Intel Corporation
- Windows 98, ME, 2000, XP are trademarks of Microsoft Corporation
- SiS is a registered trademark of Silicon Integrated Systems Corp.
- ITE is a trademark of ITE Corp.

All other product names or trademarks are properties of their respective owners.

Part No. 2002040050

1st Edition Printed in Taiwan

July 2002

Product Warranty

Advantech warrants to you, the original purchaser, that each of its products will be free from defects in materials and workmanship for one year from the date of purchase.

This warranty does not apply to any products which have been repaired or altered by persons other than repair personnel authorized by Advantech, or which have been subject to misuse, abuse, accident or improper installation. Advantech assumes no liability under the terms of this warranty as a consequence of such events.

Because of Advantech's high quality-control standards and rigorous testing, most of our customers never need to use our repair service. If an Advantech product is defective, it will be repaired or replaced at no charge during the warranty period. For out-of-warranty repairs, you will be billed according to the cost of replacement materials, service time and freight. Please consult your dealer for more details.

If you think you have a defective product, follow these steps:

1. Collect all the information about the problem encountered.
For example, CPU speed, Advantech products used, other hardware and software used, etc. Note anything abnormal and list any on-screen messages you get when the problem occurs.
2. Call your dealer and describe the problem. Please have your manual, product, and any helpful information readily available.
3. If your product is diagnosed as defective, obtain an RMA (return merchandise authorization) number from your dealer. This allows us to process your return more quickly.
4. Carefully pack the defective product, a fully completed Repair and Replacement Order Card and a photocopy proof of purchase date (such as your sales receipt) in a shippable container. A product returned without proof of the purchase date is not eligible for warranty service.
5. Write the RMA number visibly on the outside of the package and ship it prepaid to your dealer.

Packing List

The following items should come with package. If anything is missing or damaged, please consult with your vendor for resolution.

- 2 IDE HDD brackets
- 1 Key for front panel
- 1 key for mobile rack
- 1 CD Title-Driver Bank
- 1 Parallel cable
- 1 Power cord
- 1 Air filter
- 1 Mobile Rack Manual
- 1 IPC-610F User's Manual
- RS-400-SF User's Manual (in Driver Bank CD)
- 1 Warrant Card

Technical Support and Sales Assistance

If you have any technical questions about the RS-400-SF series products, please visit our support website at <http://www.advantech.com.tw/support>

For more information about Advantech products and sales information, please visit: <http://www.advantech.com>.

Contents

Chapter 1 Introduction	11
1.1 Hardware Specification	13
1.2 Software Specification	15
1.3 Environmental Specification	16
Chapter 2 Placement and Installation	17
2.1 System Placement	17
2.2 Board Layout	20
2.3 I/O Ports	21
2.4 Jumpers and Connectors on motherboard	22
2.5 Safety Precautions	24
2.6 Installing Memory	25
2.7 Memory Installation Procedures	26
2.8 Cache memory	29
2.9 CPU Installation	30
Chapter 3 BIOS Setup	35
3.1 Function Keys	36
3.2 Main Menu	37
3.2.1 Standard CMOS Features	38
3.2.2 Advanced BIOS Features	43
3.2.3 Advanced Chipset Features	47
3.2.4 Integrated Peripherals	48

3.2.5 Power Management Setup	57
3.2.6 PnP/ PCI Configurations	62
3.2.7 PC Health Status	65
3.2.8 Frequency/Voltage Control	66
3.2.9 Load Optimized Defaults	67
3.2.10 Set Password	68
3.2.11 Save & Exit Setup	69
3.2.12 Exit without Saving	70
Chapter 4 Driver Installation	71
4.1 Install VGA Driver	73
4.1.1 Driver Installation for Win98/ME	73
4.1.2 Driver Installation for Win2K/XP	74
4.1.3 Driver Installation for Linux	75
4.1.4 Driver Installation for FreeBSD 4.x	75
4.1.5 Driver Installation for QNX R6.1	75
4.2 Install LAN Driver	76
4.2.1 Driver Installation for Win98/ME	76
4.2.2 Driver Installation for Win2K/XP	78
4.2.3 Driver Installation for Linux	80
4.2.4 Driver Installation for FreeBSD 4.x	80
4.2.5 Driver Installation for QNX R6.1	80

4.3 Install PCI to ISA Bridge Driver	-----	81
4.3.1 Driver Installation for Win98/ME	-----	81
4.3.2 Driver Installation for Win2K/XP	-----	83
Appendix A Memory Approval List	-----	85
Appendix B ISA Add-on Card Approval List	-----	86
Appendix C Safety Instructions	-----	87
C.1 English	-----	87
C.2 German- Wichtige Sicherheitshinweise	-----	89

Chapter 1 Introduction

RS-400-SF is equipped with the SMB-2501, an ATX size Pentium 4 motherboard, designed for high-density Internet services, CT and industrial automation. The serverboard uses a highly integrated core logic chipset, SIS650 chipset with a high performance host interface for Intel Pentium 4 processor, a high performance 2D/3D Graphic Engine, a high performance memory controller and an AGP 4X interface. The SiS 650 integrated a high performance 2D/3D Graphic Engine, Video Accelerator and Advanced Hardware Acceleration MPEGI/MPEGII Video Decoder for the Intel Pentium 4 series based PC systems. It also integrates a high performance 2.1GB/s DDR266 Memory controller to sustain the bandwidth demand from the integrated GUI or external AGP master, host processor, as well as the multi I/O masters. In addition to the integrated GUI, the SiS650 can also support external AGP slot with AGP 4X capability and Fast Write Transactions. The SiS650 adopts a Shared Memory Architecture, eliminating the need and thus the cost of the frame buffer memory by organizing it in the system memory. The frame buffer size can be allocated from 8MB to 64MB. The Integrated GUI features a high performance 3D accelerator with 2 Pixel / 4 Texture, and a 128 bit 2D accelerator with 1T pipeline

BITBLT engine. It also features a Video Accelerator and advanced hardware acceleration logic to deliver high quality DVD playback.

The RS-400-SF has 1 AGP 4X slot, 2 PCI slots, 4 ISA slots and 1 CNR slot for function expansion. It supports maximum 5 add-on cards for PCI slots and ISA slots. ISA bus support PIO mode only, doesn't support DMA mode. CNR slot supports modem only.

The SIS650 currently supports processor front bus (PSB) 400MHz. The RS-400-SF will support PSB 533MHz once it upgrades to the SIS651 chipset.

1.1 Hardware Specifications

Processor	CPU	Intel® Pentium® 4/ Celeron CPU
	Max. Speed	2.4GHz / 1.8GHz
	L2 Cache	512 KB/128 KB
	Chipset	SIS 650
	BIOS	Award 2 Mb Flash
Bus	FSB	400 MHz
	PCI	32-bit/33 MHz
Memory	Technology	DDR-266 SDRAM
	Max. Capacity	3 GB
	Socket	DDR-266 DIMM x 3
Graphic	Controller	SIS 650 with AGP 4X
	VRAM	Shares with system memory up to 4/8/16/32/64MB
Ethernet	Interface	10/100 Base-TX
	Controller	Intel 82559ER x2
	Connector	RJ-45 x2
Expansion	AGP	1 AGP 4X slot
	PCI	2 PCI bus slots
	ISA	4 ISA bus slots*
	CNR	1 CNR slot**
Drive Bay	3.5" HDD	1 swappable HDD cartridge 2 fixed HDD bay
	3.5" FDD	1
	5.25"CD-ROM	1 (52X speed)
I/O Interface	USB	2
	Serial	2 (RS-232)
	Parallel	1 (Accessory)
	PS/2	2 (mouse x1, keyboard x1)
	CRT	1

Cooling	Fan	2 (86 CFM, 37CFM)
Operating System	Compatibility	Windows 98/ME/2000/XP, Linux Red Hat 7.x, FreeBSD 4.x, QNX R6.1
Management	Indicator	LED for power, LANs and HDDs
Miscellaneous	Control	Momentary power switch
Power Supply	Watt	300W or 400 W ATX
	Input	AC 90 ~ 264 V Full Range @47 ~ 63 Hz
Environment		Operating Non-Operating
	Temperature	0 ~ 50 °C(32 ~ 122 °F) -20 ~ 70 °C(-68 ~ 158 °F)
	Humidity	5 ~ 85 % @40 °C (104 °F) 5 ~ 95 %
Physical	Dimension (W x H x D)	482 x 177 x 502 mm (19" x 7" x 19.76")
	Weight	20.5 kg (45.1 lb)

Note: * ISA slot doesn't support DMA mode

** CNR slot supports Modem only

*** SIS651 supports PSB 400/533MHz. Motherboard
A103-1 version supports FSB 533.

RS-400-SF supports 300W ATX Power

RS-400-SF-S4 supports 400W ATX power

1.2 Software Specifications

OS support: Windows 98/ME/XP/2000

RedHat Linux 6.x/7.x

FreeBSD 4.x, QNX R6.1

*** No support for Win NT Series**

1.3 Environmental Specifications

- **Operating temperature:** 0 ~ 50° C
- **Storage temperature:** -40 ~ 75° C (-40 ~ 167° F)
- **Operating Humidity:** 10 ~ 85% @ 40°C
- **Storage Humidity:** 5~95%

Chapter 2 Placement and Installation

2.1 System Placement

2.1.1 Frontal View

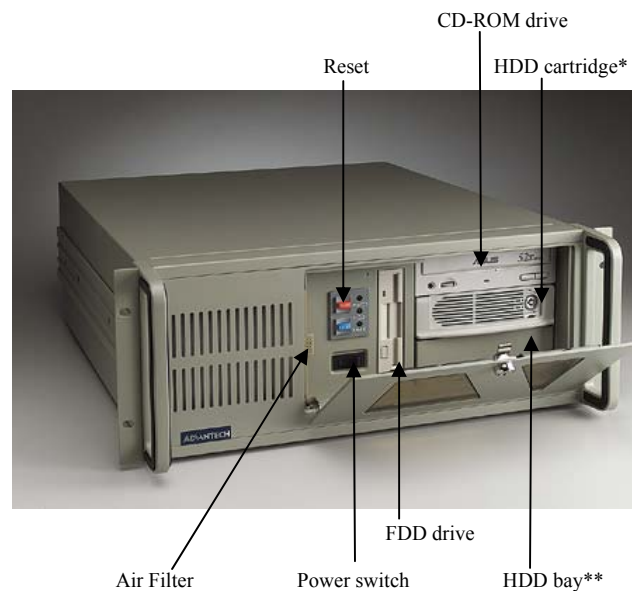

Note:

*- Please refer to mobile rack manual in accessory box.

** - Please refer to section 2.2 “adding your disk drives” in the manual of IPC-610F Industrial Chassis. When you install HDD drive, it is necessary to fix HDD bracket in accessory box on the two sides of the HDD drive first.

2.1.2 Rear View

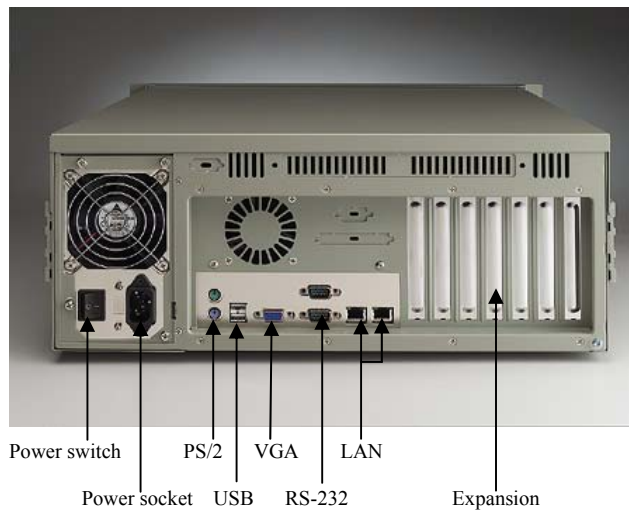

2.1.3 Top View



Please refer to IPC-610 Manual (IPC-610MB) for more information about its mechanism.

2.2 Board Layout

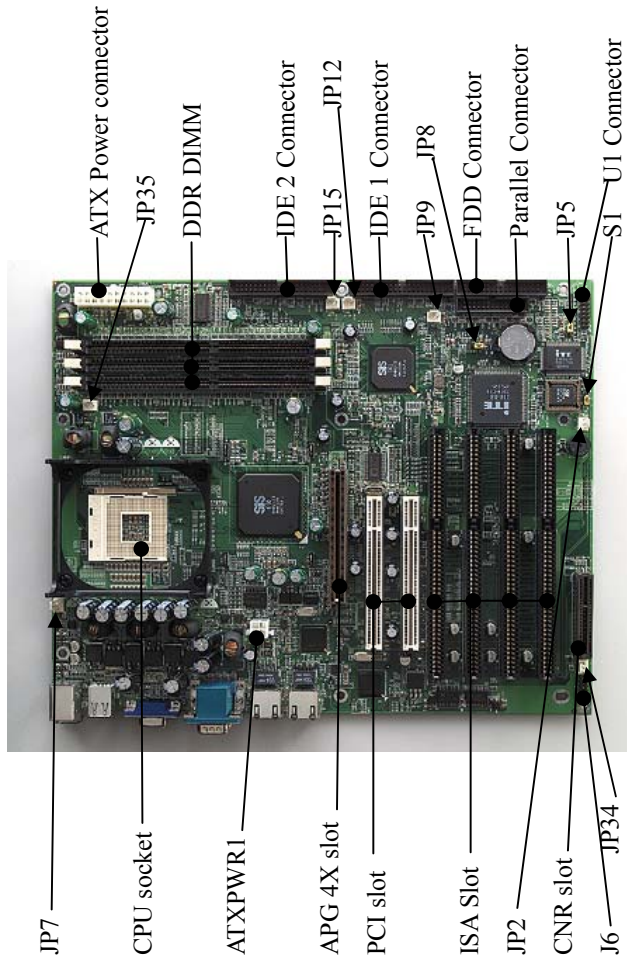

2.3 I/O Ports

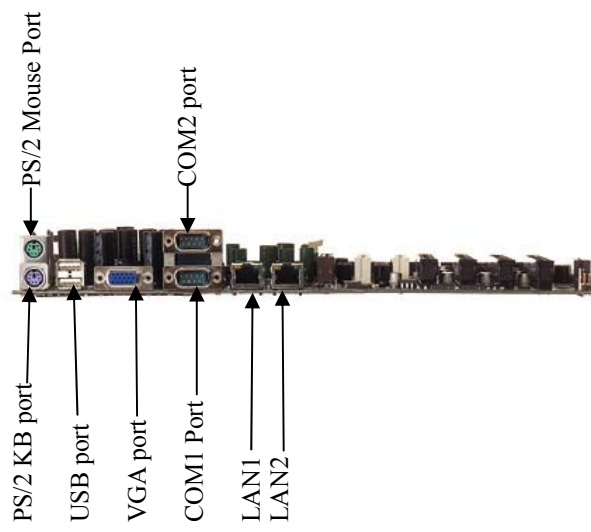

2.4 Jumpers and Connectors on motherboard

U1-Power Bottom /Reset /IDE LED/LAN LED

Pin	Function	Remark			
1-2	Power On				
3-4	Reset				
5-6	LAN1 LED	5	Signal	6	VCC5
7-8	LAN2 LED	7	Signal	8	VCC5
9-10	IDE Channel 0 LED	9	Signal	10	VCC5
11-12	IDE Channel 1 LED	11	Signal	12	VCC5

J5-POWER LED

Pin	Function	Remark			
1-3	POWER LED	1	Vcc3	2, 3	GND

JP5-SUPER I/O BATTERY SUPPLY

Pin	Function	Remark
1-2	POWER FROM BATTERY	
2-3	POWER FROM SB3V	Close*

Default: 2-3 close

S1-Flash ROM Size

Pin	Function	Remark
1-2	ROM Size is 2Mbit	Close
2-3	ROM Size is 4Mbit	

Default: 1-2 close

JP8-RTC CMOS Jumper setting.

Pin	Function	Remark
1-2	CMOS Clear	
2-3	RTC COMS Active	Close

Default: 2-3 close

JP38-SPEAKER SELECT

Jumper	Function	Remark
1-2	Internal BUZZER	Close
2-3	External SPEAKER	

Fan Connectors: JP2, JP7, JP9, JP12, JP15, JP34, JP35

Pin	Function
1	Ground
2	12V
3	TACK (Sensor)

*JP 35 is used for CPU fan

2.5 Safety Precautions

Warning! Always completely disconnect the power cord from your chassis whenever you work with the hardware. Do not make connections while the power is on. Sensitive electronic components can be damaged by sudden power surges. Only experienced electronics personnel should open the PC chassis.

Caution! Always ground yourself to remove any static charge before touching the CPU card. Modern electronic devices are very sensitive to static electric charges. As a safety precaution, use a grounding wrist strap at all times. Place all electronic components in a static-dissipative surface or static-shielded bag when they are not in the chassis.

2.6 Installing Memory

The SMB-2501 contains three sockets for 184-pin dual inline memory modules (DIMMs). All these sockets accept un-buffered DDR266 SDRAMs. The un-buffered DDR266 DIMMs are available in 128, 256, 512 and 1024 MB. The sockets can be filled in any combination with DDR DIMMs of any size, allowing the SMB-2501 up to 3 GB of memory.

2.7 Memory Installation Procedures

To install DDR DIMMs, first make sure the two handles of the DDR DIMM socket are in the "open" position. i.e. The handles lean outward. Slowly slide the DDR DIMM module along the plastic guides on both ends of the socket. Then press the DDR DIMM module right down into the socket, until you hear a click. This is when the two handles have automatically locked the memory module into the correct position of the DDR DIMM socket. To remove the memory module, just push both handles outward, and the memory module will be ejected by the mechanism in the socket.

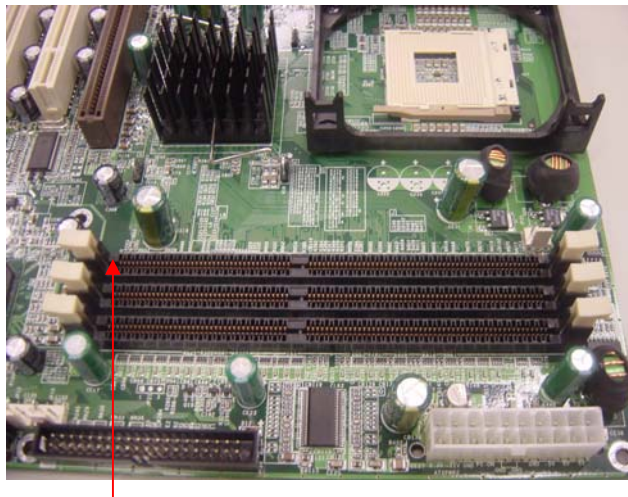

DDR DIMM (184 pin)

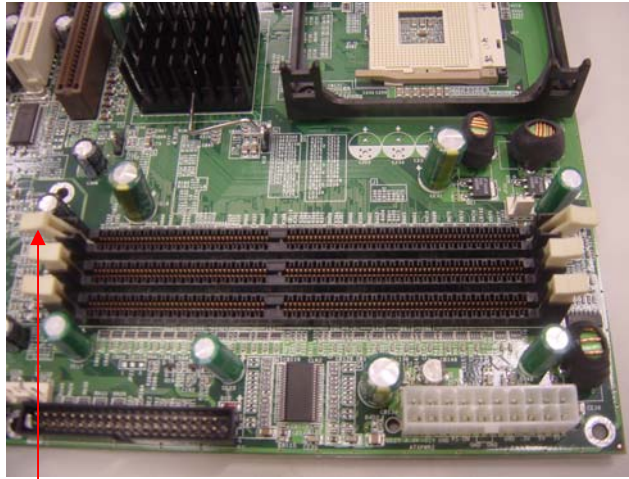

Press the socket retaining latches back out of the way

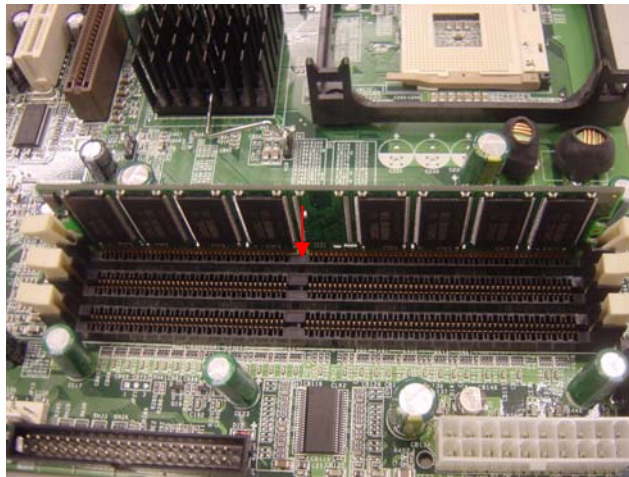

Orient the DDR DIMM so that the edge connector sections correctly match the socket sections. Holding the DIMM to

the socket, place it in the socket so that the edge connectors insert slightly in the socket. Make sure they match.

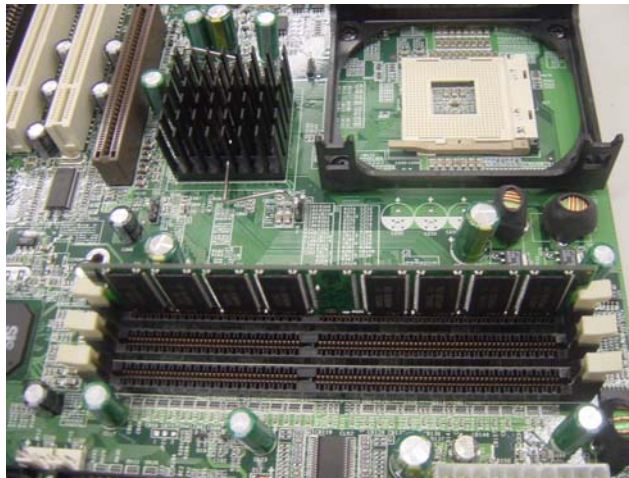

Press the DDR DIMM into the socket so that it seats firmly in place and the retaining latches rotate upwards and seat themselves in the notches on the side of the DDR DIMM.

Repeat this operation for the rest of DIMMs you will install.

2.8 Cache Memory

Since the second level (L2) cache has been embedded into the Intel® Pentium® 4 / Celeron processor, you do not have to take care of either SRAM chips or SRAM modules. The built-in second level cache in the Pentium® 4/ Celeron processor yields much higher performance than the external cache memories. The cache size in the Intel® Pentium® 4 processor is 512 or 256 KB, depending on the type of CPU. The cache size in the Intel® Celeron processor is 128KB.

2.9 CPU Installation

The SMB-2501 provides an mPGA 478 socket for an Intel® Pentium® 4/ Celeron Processor. The CPU on the board must have a fan or heat sink attached, to prevent overheating.

Warning: Without a fan or heat sink, the CPU will overheat and cause damage to both the CPU and the motherboard.

To install a CPU, first turn off your system.

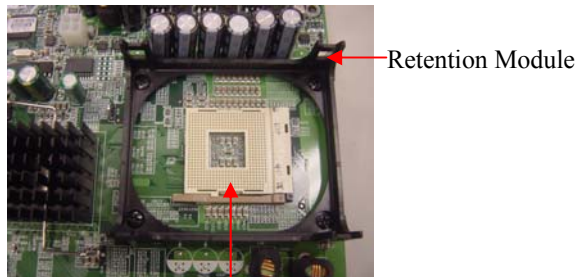

Locate the processor socket 478.

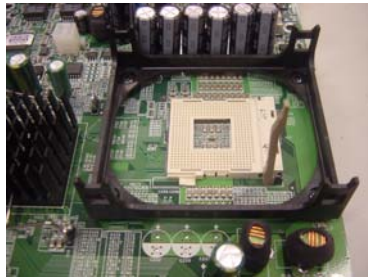

Make sure the socket 478 lever is in the upright position. To raise the lever, pull it out to the side a little and raise it as far as it will go.



Place the CPU in the empty socket. Follow the instructions that came with the CPU. If you have no instructions, complete the following procedure. Carefully align the CPU so it is parallel to the socket and the notches on the corners of the CPU correspond with the notches on the inside of the socket. Gently slide the CPU in. It should insert easily. If it does not insert easily, pull the lever up a little bit more.



Press the lever down. The plate will slide forward. You will feel some resistance as the pressure starts to secure the CPU in the socket. This is normal and will not damage the CPU. When the CPU is installed, the lever should snap into place at the side of the socket.

Note: To remove a CPU, pull the lever out to the side a little and raise it as far as it will go. Lift out the CPU.



Paint the heat-spread glue on the CPU evenly.
(It is recommended, but some CPU cooler fan comes with a thermal pad).

After a CPU has been installed, you will need to **install the proper cooling device** for the CPU.



Place CPU cooler fan to sit on the top of installed CPU



Make the hooker of fan portion hook the retention module

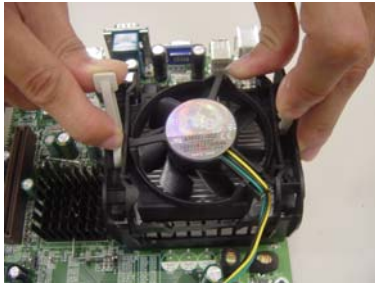

Press the two levers down to fasten the fan. Each lever can be pressed down in only one direction.



The levers have been pressed down already.

Please connect the fan power cable JP35 to the 3-pin fan power connector on the board.

Chapter 3 BIOS Setup

Award BIOS ROM has a built-in Setup program that allows users to modify the basic system configuration. This type of information is stored in battery-backed RAM (CMOS RAM), so that it retains the Setup information when the power is turned off.

You should be able to use the BIOS optimized default settings as they come from the factory. If you want to check or alter BIOS settings, run the CMOS Setup Utility by pressing the “**Del**” key command during the POST. If you think the settings need to be refreshed, run the Setup Utility, choose the “**Load Optimized Defaults**” option from the main menu, save and reboot.

3.1 Function Keys

The Function Keys are located at the bottom of CMOS setup screen. The keys allow users to navigate then main setup menu. The following table lists describe their functions.

Key	Function Description
Esc	Jump to Exit menu or return to the main menu from sub-menu
↑ or ↓	Move the cursor to the up or down between fields
← or →	Select the menu item to the left or the right
Enter	Select menu item
F10	Save & Exit Setup

The Function keys of **sub-menu** are described as below:

Key	Function Description
Esc	Jump to Exit menu or return to the main menu from sub-menu
↑ or ↓	Move the cursor to the up or down between fields
← or →	Select the menu item to the left or the right
PU/PD	Modify the value or setting
+/-	Modify the value or setting
Enter	Select the menu item
F1	Display the General Help screen from anywhere in the BIOS Setup
F5	Load Previous Values
F7	Load Optimized Defaults
F10	Save the setting

3.2 Main Menu

When the Setup program is accessed, the following screen appears. Move arrow keys to the appropriate place you will setup and press “**Enter**” for selection.

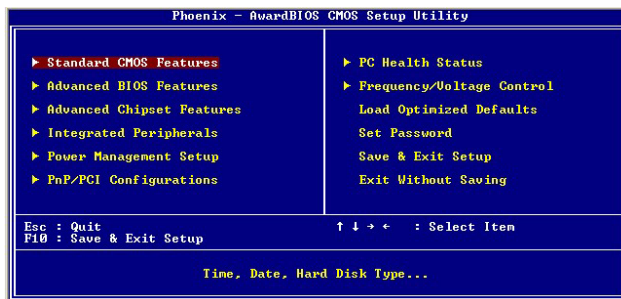

When BIOS CMOS setup has been completed, data in the CMOS RAM is automatically backed up to the Flash ROM. This is particularly useful in industrial environments that may cause soft errors. Upon such an error occurring, BIOS will check the data, and automatically restore the original data for booting.

3.2.1 Standard CMOS Features

Choose the “Standard CMOS Features” option from the main menu. The “Standard CMOS Features” allows users to configure system components such as date, time, hard disk drive and floppy drive types showed in the screen below:

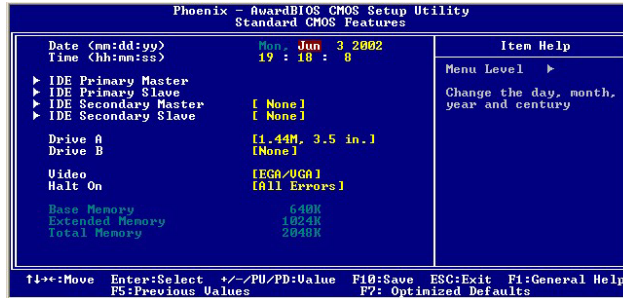

Date (mm:dd:yy): Set the system date. The format is month, day and year. Move to proper place by arrow keys in order to modify the values by Page Up/+ Key or Page Down/- Key.

Time (hh:mm:ss): change internal clock.

IDE Primary Master: Move the highlight to the “**IDE Primary Master**” and enter to get the following screen.

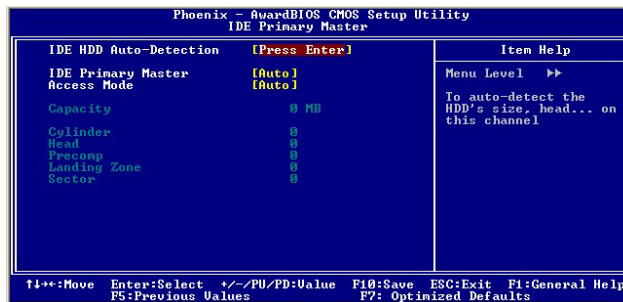

IDE HDD Auto-Detection: To auto-detect the capacity, cylinder, head and sector of HDD

IDE Primary Master: [Auto/Manual/None]

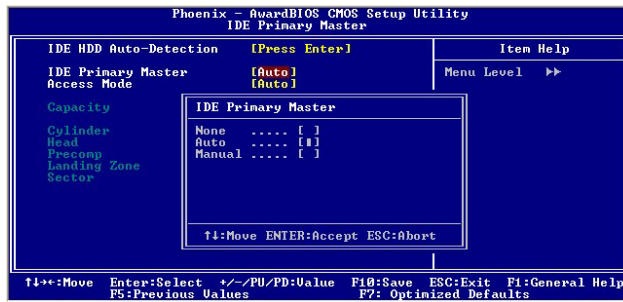

Access Mode: **[Auto/Large/LBA/CHS]**

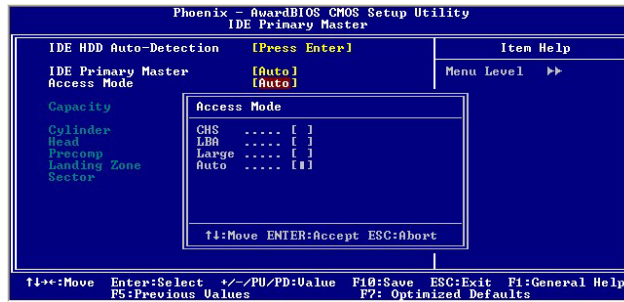

IDE Primary Slave: Choose the option then get the following three items.

IDE HDD Auto-Detection: To auto-detect the capacity, cylinder, head and sector of HDD

IDE Primary Slave: **[Auto/Manual/None]**

Access Mode: **[Auto/Large/LBA/CHS]**

IDE Secondary Master: Choose the option then get the following three items.

IDE HDD Auto-Detection: To auto-detect the capacity, cylinder, head and sector of HDD

IDE Secondary Master: **[Auto/Manual/None]**

Access Mode: **[Auto/Large/LBA/CHS]**

IDE Secondary Slave: Choose the option then get the following three items.

IDE HDD Auto-Detection: To auto-detect the capacity, cylinder, head and sector of HDD

IDE Secondary Slave: [**Auto/Manual/None**]

Access Mode: [**Auto/Large/LBA/CHS**]

Drive A: Set the type of floppy drive installed by Page Up Key and Page Down Key.

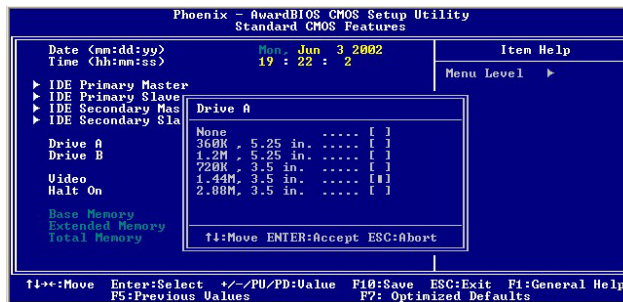

Halt On: Set system halt on when specified item occurs. The selection items are showed in the following screen.

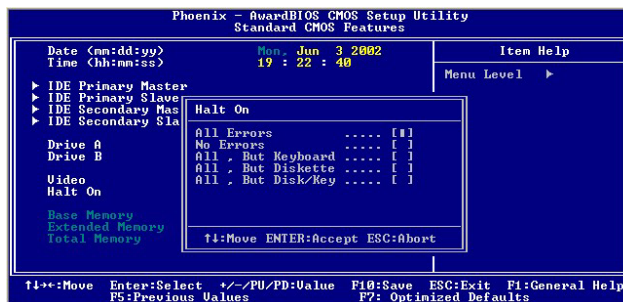

3.2.2 Advanced BIOS Features

Choose the “Advanced BIOS Features” option from main menu.

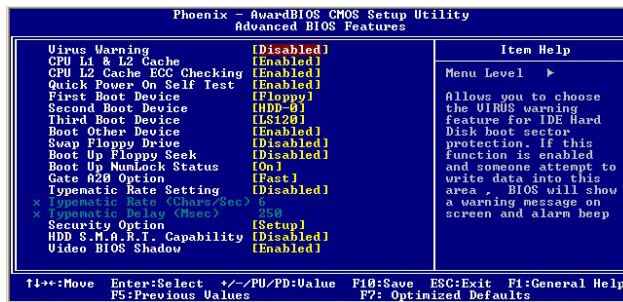

Virus Warning: Allows you to choose the virus warning feature for IDE hard disk boot sector protection. If this function is enabled and someone attempt to write data into this area, BIOS will show a warning message on screen and alarm beep.

CPU L1 & L2 Cache [Enabled/ Disabled]

CPU L2 Cache ECC checking [Enabled/ Disabled]

Quick Power On Self Test (POST) [Enabled/Disabled]:

Allows the system to skip certain tests while booting. This will decrease the time needed to boot the system.

First Boot Device

[Floppy/SCSI/CD-ROM/HDD/LAN/Disabled]: Select your boot device priority

Second Boot Device

[Floppy/SCSI/CD-ROM/HDD/LAN/Disabled]: Select your boot device priority

Third Boot Device

[Floppy/SCSI/CD-ROM/HDD/LAN/Disabled]: Select your boot device priority

Boot Other Device [Enabled/Disabled]: Select your boot device priority

Swap Floppy Drive [Enabled/Disabled]: If the system has two floppy drives, choose physical drive B to logical drive A and vice versa.

Boot Up Floppy Seek [Enabled/Disabled]: **Enable-**During POST, BIOS will determine if the floppy disk drive installed is 40 or 80 tracks. A 360 KB type drive is 40 tracks; while 720 KB, 1.2 MB, and 1.44 MB type drives are all 80 tracks. **Disable-** BIOS will not search for the floppy drive type by track number.

Boot on NumLock status [On/Off]: Select power on state for NumLock.

Gate A20 Option [Fast/Normal]: **Fast-** let chipset control Gate A20; **Normal-**a pin in keyboard controller controls Gate A20. Default is set “**Fast**”.

Typematic Rate Setting [Enabled/Disabled]: Keystrokes repeat at a rate determined by keyboard controller. When enabled, the typematic rate and typematic delay can be selected.

Typematic Rate (Chars/Sec): BIOS accepts the following input values (characters/second) for typematic rate: 6, 8, 10, 12, 15, 20, 24 and 30.

Typematic Delay (msec): Typematic delay is the time interval between the appearances of two consecutive characters, when holding down a key. The input values for this category are: 250, 500, 750, 1000 (msec).

Security Option [System/Setup]: The setting determines whether the system will boot up if the password is denied. Access to Setup is, however, always limited. **System-** The system will not boot, and access to Setup will be denied if

the correct password is not entered at the prompt. **Setup-**
The system will boot, but access to Setup will be denied if
the correct password is not entered at the prompt.

HDD S.M.A.R.T. Capability [Enabled/Disabled]: This
allows you to activate the SMART (Self-Monitoring
Analysis & Reporting Technology) capability for the hard
disks. SMART is a utility that monitors your disk status to
predict hard disk failure. This gives you an opportunity to
move data from a hard disk that is going to fail to a safe
place before the hard disk becomes offline.

Video BIOS Shadow [Enabled/ Disabled]: Enable copies
video BIOS to shadow RAM for performance improving.

3.2.3 Advanced Chipset Features

Choose the “Advanced Chipset Features” option from main menu.

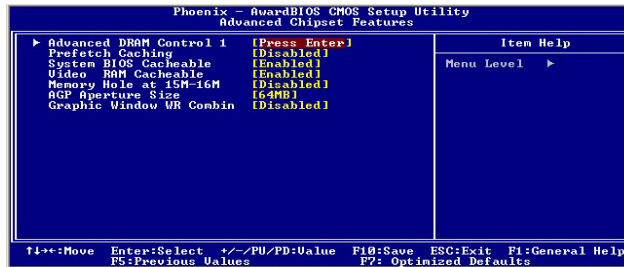

Advanced DRAM Control 1: Move the highlight to the “Advanced DRAM Control 1” and enter to get the following screen.

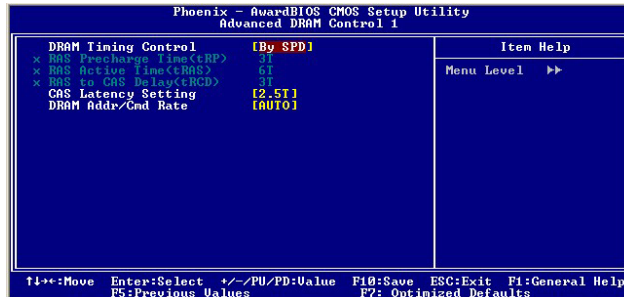

DRAM Timing Control [By SPD/ Manual]: Set “By SPD” to enable DRAM Timing Control automatically to be determined by BIOS based on the configurations on the SPD (Series Presence Detect) EEPROM on the DRAM module.

3.2.4 Integrated Peripherals

Choose the “**Integrated Peripherals**” option from main menu.

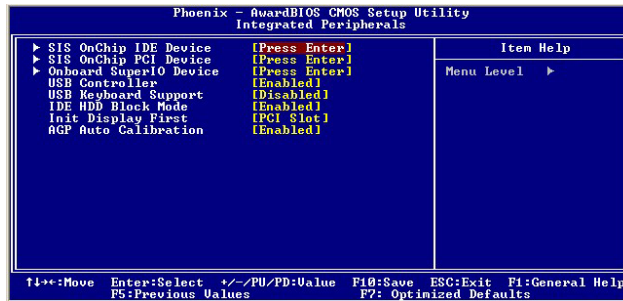

SIS OnChip IDE Device: Move the highlight to the “**SIS OnChip IDE Device**” and enter to get the following screen.

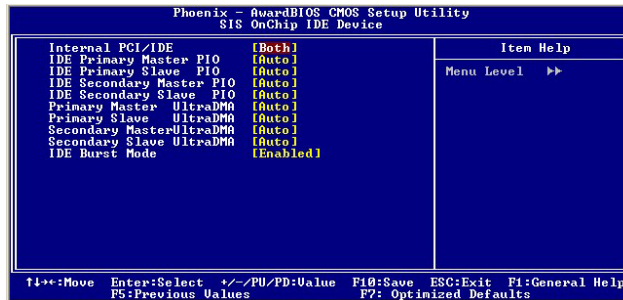

Internal PCI/IDE [Both/Primary/Secondary/Disabled]:

The system provides an onboard on-chipset PCI IDE controller that supports Dual Channel IDE. A maximum of 4 IDE devices can be supported. If user installed the Off-Board PCI IDE controller, the user must choose which channels to disable. This will depend on the channel used in the PCI Off-Board add-on card. Normally select “**Both**”

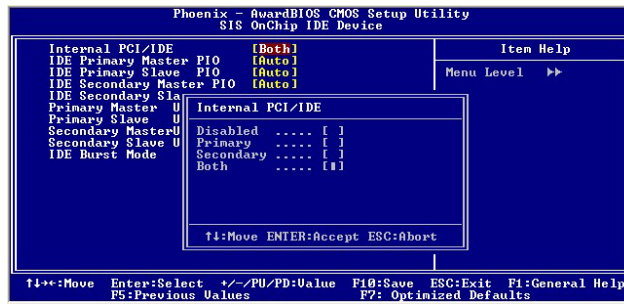

IDE Primary Master/Slave PIO [Auto/Mode0/Mode 1-4]

Each channel has both a master and a slave, making four IDE devices possible. Because each IDE device may have a different timing (0, 1, 2, 3, 4) mode, it is necessary for these to be independent. The default setting “**Auto**” will allow auto-detection to ensure optimal performance.

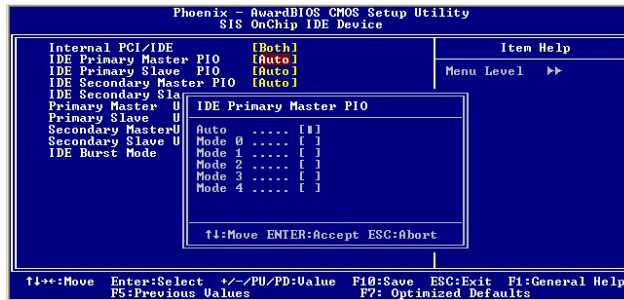

IDE Primary Master/Slave UDMA [Auto/Disabled]:

Each channel (Primary and Secondary) has a master and a slave, making four IDE devices possible. Because each IDE device may have a different timing (0, 1, 2, 3, 4) mode, it is necessary for these to be independent. The default setting “Auto” will allow auto-detection to ensure optimal performance.

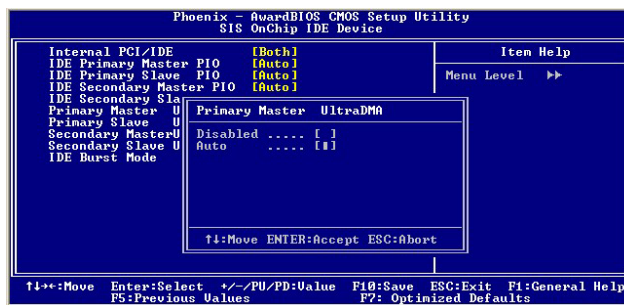

IDE Burst Mode [Enabled/Disabled]:



On-Chip Secondary PCI IDE [Enabled/Disabled]
IDE Secondary Master/Slave PIO [Auto/Mode0/Mode
1-4]

IDE Secondary Master/Slave UDMA [Auto/Disabled]

SIS OnChip PCI Device:

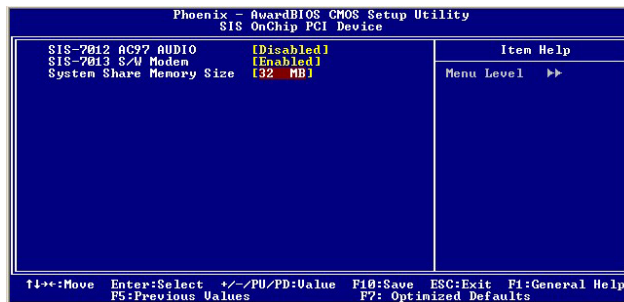

SIS-7012 AC97 AUDIO [Disabled/Enabled]: Default is set Disabled.

SIS-7013 S/W Modem [Disabled/Enabled]: Please set Enable when system installs CNR Modem

System Shares Memory Size [4/8/16/32/64MB]: The memory size you choose will be used by internal VGA as Video memory.

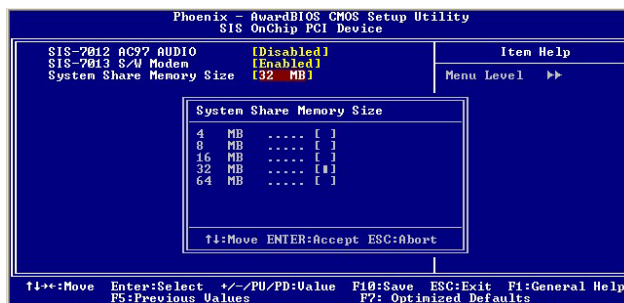

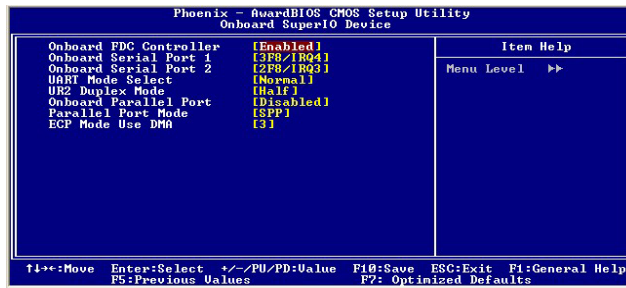

Onboard FDC Controller [Enabled/Disabled]: The system has an on-board Super I/O chip with a FDD controller that supports a FDD drive for 360K/720K/1.2M/1.44M. Choose “**Enabled**” to use the on-board FDD controller for accessing the FDD. Otherwise please select “**Disabled**” to use the off-board FDD controller.

Onboard Serial Port 1

[Auto/Disable/(3F8/IRQ4)/(2F8/IRQ3)]

Onboard Serial Port 2

[Auto/Disable/(3F8/IRQ4)/(2F8/IRQ3)]

The system has an on-board Super I/O chipset with 2 serial ports. The on-board serial ports can be selected as:

Auto

Disable

3F8/IRQ4 COM 1 uses IRQ4

2F8/IRQ3 COM 2 uses IRQ3

UART Mode Select [Normal/IrDA/ASKIR/SCR]

UR2 Duplex Mode [Half/ Full]

Onboard Parallel Port: This field sets the address of the on-board parallel port connector. You can select either 3BC/IRQ7, 378/IRQ7, 278/IRQ5 or Disabled. If you install an I/O card with a parallel port, make sure there are no conflicts in the address assignments. The CPU card can support up to three parallel ports, as long as there are no conflicts for each port.

Parallel Port Mode (ECP + EPP): This field allows you to set the operation mode of the parallel port. The SPP setting allows normal speed operation, but in one direction only. “EPP” allows bi-directional parallel port operation at maximum speed. “ECP” allows the parallel port to operate in bi-directional mode and at a speed faster than the maximum data transfer rate. “ECP + EPP” allows normal speed operation in a two-way mode.

ECP Mode Use DMA: In **ECP Mode Use DMA**, you can select DMA channel 1 or DMA channel 3. Leave this field based on the default setting.

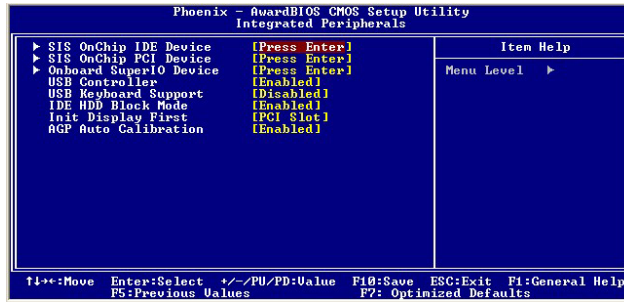

USB Controller [Enabled/Disabled]

USB Keyboard Support [Enabled/Disabled]: Choosing “Enabled” will allow the system to use USB keyboard without device driver.

IDE HDD Block Mode [Enabled/Disabled]: Enabled allows the Block mode access for the IDE HDD

Init Display First [PCI slot/ AGP]

AGP Auto Calibration [Disabled/ Enabled]

3.2.5 Power Management Setup

Choose the “Power Management Setup” option from the main menu.

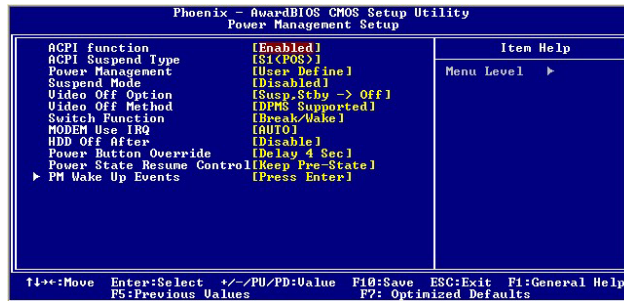

ACPI function [Enabled/ Disabled]

ACPI Suspend Type

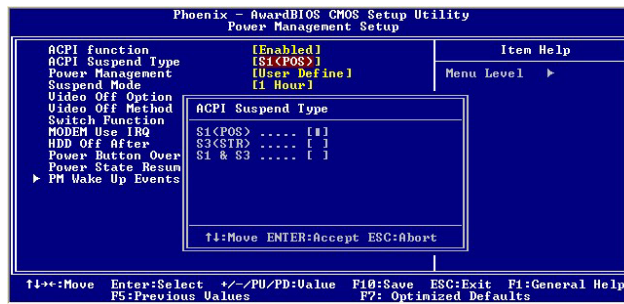

Power Management:

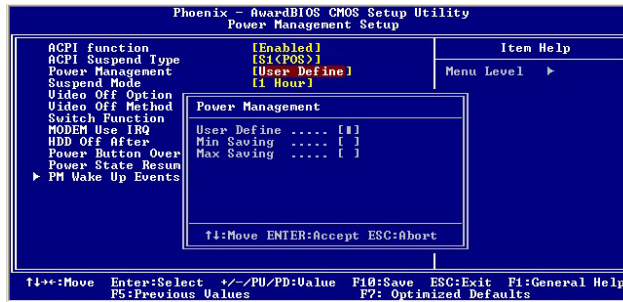

Suspend Mode:

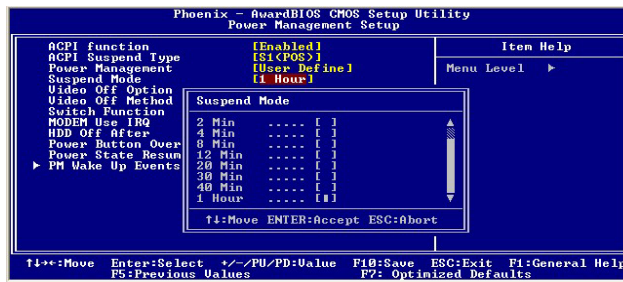

Video Off Option:

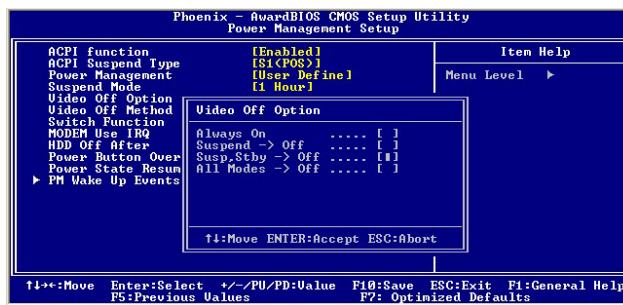

Video Off Method:

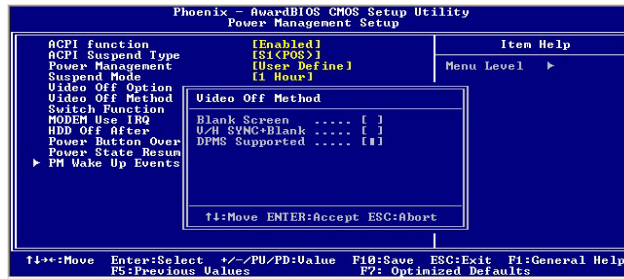

Switch Function:

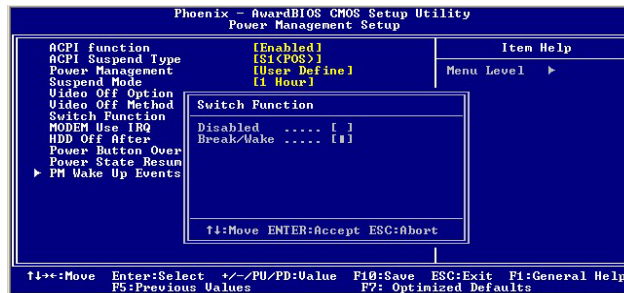

MODEM Use IRQ:

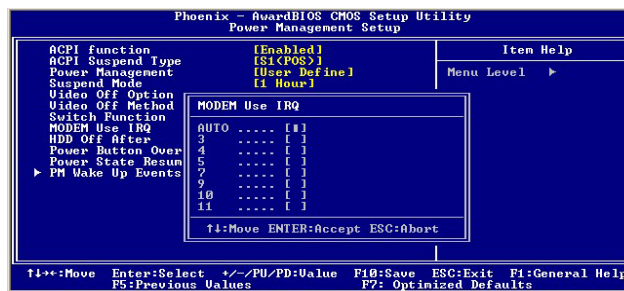

HDD Off After:

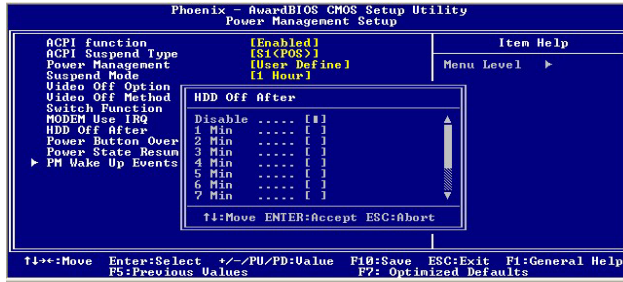

Power Button Override:



Power State Resume Control:



PM Wake Up Events:

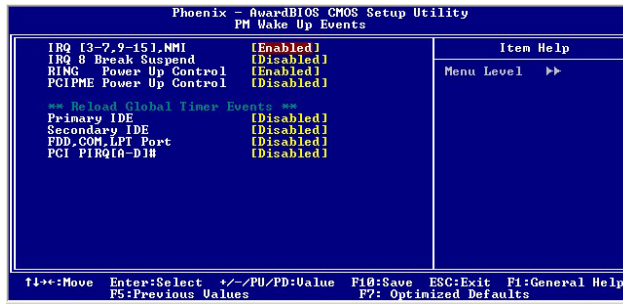

3.2.6 PnP/ PCI Configurations

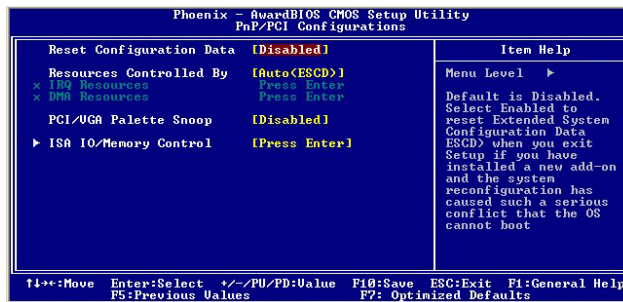

Reset Configuration Data [Disabled/Enabled]: Default is “Disabled”. If you have installed a new add-on and the system reconfiguration has caused a conflict for the OS to not boot, select “Enable” to reset Extended System Configuration Data (ESCD) when you exit Setup.

Resources Controlled by [Auto/Manual]: BIOS can automatically configure all the boot, and plug & play compatible devices. If you choose “Auto”, you cannot select IRQ, DMA and memory base address fields, since BIOS automatically assigns them.

When resources are controlled manually, assign each system interrupt a type, depending on the type of device using the interrupt.

IRQ-3/4/5/7/9/10/11/12/14/15 can be assigned PCI/ISA PnP or Legacy ISA.

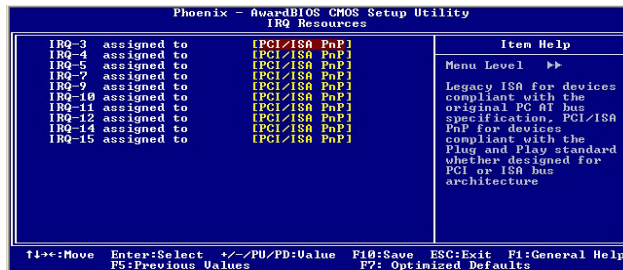

When resources are controlled manually, assign a type to each system DMA channel a type, depending on the type of device that is using the DMA channel.

DMA-0/1/3/5/6/7 can be assigned to PCI/ISA PnP or Legacy ISA

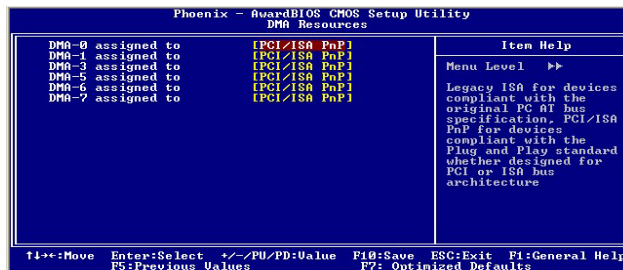

PCI/VGA Palette Snoop [Disabled/Enabled]: Some display cards that are nonstandard VGA, such as graphics accelerators or MPEG Video Cards, may not show the proper colors. The **Enabled** setting should correct this problem. Otherwise, leave this on the setup default setting of **Disabled**. Recommend set **Disabled**.

ISA IO/Memory Control:

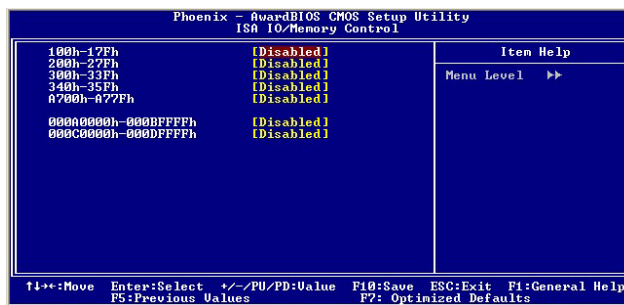

3.2.7 PC Health Status

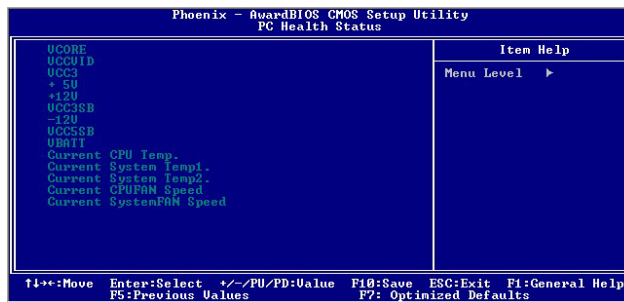

The system can monitor system voltage, CPU voltage, CPU temperature, system temperature, CPU fan speed and system fan speed.

3.2.8 Frequency/ Voltage Control

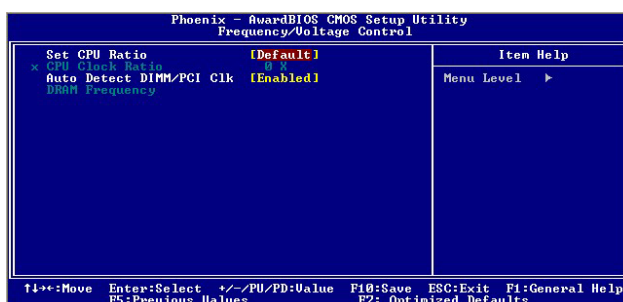

Set CPU Ratio [Manual/Default]: The “Manual” option allows to set CPU clock ratio. Normally, please set “Default”.

Auto Detect DIMM/PCI Clk [Enabled/Disabled]:

CPU: DRAM Clock Ratio: This setting controls the ration frequency CPU FSB Clock & DRAM Frequency to enable the CPU & DRAM and run under different frequency combinations. Please note that the setting options vary according to the CPU FSB Clock preset.

3.2.9 Load Optimized Defaults

The option allows you to load the optimized default values for each of the parameters on the Setup menus. When this option is pressed, a confirmation is requested. Select “Y” to load the optimized default values. Select “N” or press “Esc” to discard the selection.

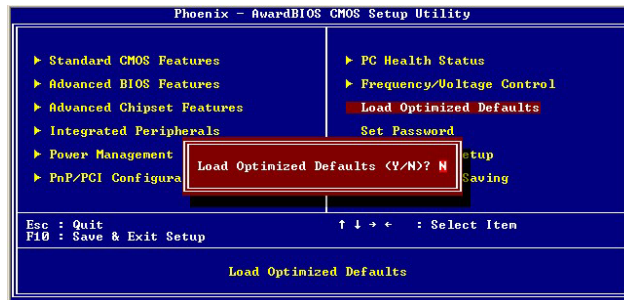

3.2.10 Set Password

This option allows you to set or change user password. To set the user password, press “**Enter**”. Type password and press “**Enter**”. You can type up to eight alphanumeric characters.



If the CMOS is good or if this option has been used to change the default password, the user is asked for the password stored in the CMOS. The screen will display the following message:

Confirm Password:

Input the current password and press “**Enter**”.

3.2.11 Save & Exit Setup

Choose the save option to save the values you selected to CMOS RAM. The CMOS RAM is sustained by an on-board backup battery, and stays on even when the system is turned off. Once the option is selected, a confirmation will be asked. Select “Y” to save changes and exit.

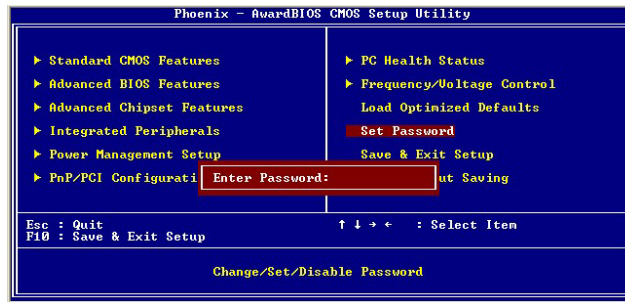

3.2.12 Exit without Saving

The option should only be used if you do not want to save the changes you have made to the Setup program. If you have made changes to the fields, the system will ask for confirmation before exiting. Select “Y” then the system will keep the previous values.

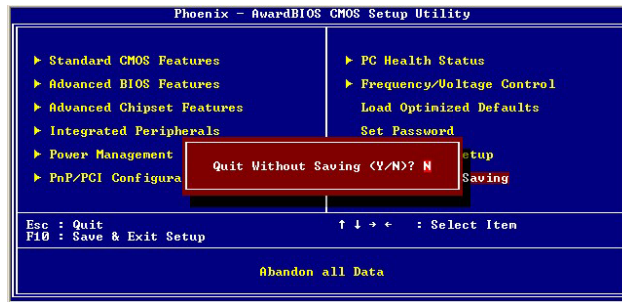

Chapter 4 Driver Installation

The servers support several Operating Systems including Microsoft Windows 98/ME/2000/XP, Linux 7.x, Free BSD 4.x and QNX R6.1.

In the driver bank CD disc, there are some options as pictured below, when running “Setup” or CD auto-run.



The motherboard is used for SMB-2501, RS-100-SF and RS-400-SF. After clicking the icon-“SMB-2501” or “RS100/400-SF”, the following screen will be displayed.



There are four selections on the screen above: 1) Install VGA driver 2) Install LAN driver 3) Install PCI to ISA Bridge driver 4) Manual

4.1 Install VGA Driver

Click "**Install VGA driver**" selection. There are two folders- "**Win98&ME**" and "**Win2K&XP**"

4.1.1 Driver Installation for Win 98/ME

4.1.1.1 Open "**Win98&ME**" folder.

4.1.1.2 Execute "**setup.exe**"

4.1.1.3 During the installation, there will be three setups you can choose from:

- **Typical**

Install all of the components from this package, including VGA driver and utilities.

- **Compact**

Install driver only.

- **Custom**

Install components of your choice.

It is recommended to choose "**Typical**".

4.1.1.4 Restart your computer when the installation is complete.

4.1.2 Driver Installation for Win 2K/XP

4.1.2.1 Open “**Win2K&XP**” folder.

4.1.2.2 Execute “**setup.exe**”

4.1.2.3 During the installation, there three setup you can choose will be:

- **Typical**

Install all of components from this package, including VGA driver and utilities.

- **Compact**

Install driver only.

- **Custom**

Install components of your choice.

It is recommended to choose “**Typical**”.

4.1.2.4 Restart your computer when the installation is complete.

4.1.3 Driver Installation for Linux

Linux RedHat 7.x system can correctly recognize SiS 650 compatible VGA controller (SiS 300). It is not necessary for user to load or modify the VGA driver for the onboard VGA device.

4.1.4 Driver Installation for FreeBSD 4.x

Since FreeBSD 4.x OS cannot correctly recognize SiS 650 compatible VGA controller, the system supports text mode only.

4.1.5 Driver Installation for QNX R6.1

QNX R6.1 system cannot correctly recognize SiS 650 compatible VGA controller but Standard VGA driver. It is not necessary to load or modify the VGA driver for the onboard VGA device.

4.2 Install LAN Driver

4.2.1 Driver Installation for Win 98SE/ME

4.2.1.1 Boot Windows from your hard disk and insert the driver bank CD disc containing the LAN driver.

4.2.1.2 Click the **“Start”** button, then select **“Settings”**, and click on the **“Control Panel”** to select **“System”**.

4.2.1.3 In the **"System Properties"** window, select the **"Device Manager"** tab. Select **"View devices by type"**, and navigate to: **“Computer\Other”** devices. Highlight **"PCI Ethernet Controller"** and click on **"Properties"**.

4.2.1.4 In the **"PCI Ethernet Controller Properties"** window, select the **"Driver"** tab. Then click on **"Update Driver..."**.

4.2.1.5 In the **"Update Device Driver Wizard"** window, click on **"Next"**.

4.2.1.6 In the **"Update Device Driver Wizard"** window, select **"Search for a better driver than the one your device is using now. (Recommended)"** Then click on **"Next"**.

4.2.1.7 In the **“Update Device Driver Wizard”** window, click on **"Browse"**.

- 4.2.1.8 Click Specify a location and click **“Browse”** button.
Then, navigate to **“F:\82559er”** (where **“F”** should be substituted as your CD-ROM drive), and click **“Next”**.
- 4.2.1.9 Click **“Next”** to accept the updated driver for **“Intel(R) GD82559ER Fast Ethernet Adapter”**.
Click **“Next”** to continue with LAN driver installation.
- 4.2.1.10 Follow the instructions on the screen. Click **“Finish”** to complete installation.
- 4.2.1.11 Restart the computer to finish LAN driver setup.

4.2.2 Driver Installation for Win 2K/XP

4.2.2.1 Boot Windows from your hard disk and log in as Administrator.

4.2.2.2 From the “**Control Panel**”, double-click the “**System**” icon, select the “**Hardware**” tab, and click the “**Device Manager**” button.

4.2.2.3 Expand the “**Computer\Other**” devices. Highlight “**PCI Ethernet Controller**” and click on “**Properties**”.

4.2.2.4 From the “**Properties**” dialog box, click the “**Driver**” tab and click the “**Update Driver**” button. The Update Device Driver Wizard appears. Click “**Next**”.

4.2.2.5 In the “**Update Device Driver Wizard**” window, select “**Display a list of the known drivers for this device**”.

4.2.2.6 Click “**Hard have...**”. Click Specify a location and click “**Browse**” button. Then, navigate to “**F:\82559er**” (where “**F**” should be substituted as your CD-ROM drive), and click “**Next**”.

4.2.2.7 Click “**Next**” to accept the updated driver for “**Intel(R) GD82559ER Fast Ethernet Adapter**”. Click “**Next**” to continue with LAN driver installation.

4.2.2.8 Follow the instructions on the screen. Click **“Finish”** to complete installation.

4.2.3 Driver Installation for Linux

Linux RedHat 7.x system can correctly recognize Intel 82559ER Fast Ethernet controller. It is not necessary to load or modify the network driver for the onboard LAN device. (However, the LAN driver for Linux also be put on driver bank CD.)

4.2.4 Driver Installation for FreeBSD 4.x

FreeBSD 4.x system can correctly recognize Intel 82559ER Fast Ethernet controller. It is not necessary to load or modify the network driver for the onboard LAN device.

4.2.5 Driver Installation for QNX R6.1

QNX R6.1 system can correctly recognize Intel 82559ER Fast Ethernet controller. It is not necessary to load or modify the network driver for the onboard LAN device.

4.3 Install PCI to ISA Bridge Driver

4.3.1 Driver Installation for Win 98SE/ME

4.3.1.1 Boot Windows from your hard disk.

4.3.1.2 Click the "**Start**" button, then select "**Settings**", and click on the "**Control Panel**" to select "**System**".

4.3.1.3 In the "**System Properties**" window, select the "**Device Manager**" tab. Select "**View devices by type**", and navigate to: "**Computer\Other**" devices. Highlight "**Other PCI Bridge Device**" and click on "**Properties**".

4.3.1.4 In the "**Other PCI Bridge Device**" window, select the "**Driver**" tab. Then click on "**Update Driver...**".

4.3.1.5 In the "**Update Device Driver Wizard**" window, click on "**Next**".

4.3.1.6 In the "**Update Device Driver Wizard**" window, select "**Search for a better driver than the one your device is using now. (Recommended)**" Then click on "**Next**".

4.3.1.7 In the "**Update Device Driver Wizard**" window, click on "**Browse**"

- 4.3.1.8 Click Specify a location and click **“Browse”** button.
Then, navigate to **“F:\ITE8888”** (where **“F”** should be substituted as your CD-ROM drive), and click **“Next”**.
- 4.3.1.9 Click **“Next”** to accept the updated driver for **“ITE 8888 PCI to ISA bridge”**. Click **“Next”** to continue with driver installation.
- 4.3.1.10 Follow the instructions on the screen. Click **“Finish”** to complete installation.
- 4.3.1.11 Restart the computer to finish driver setup.

4.3.2. Driver Installation for Win 2K/XP

4.3.2.1 Boot Windows from your hard disk and log in as Administrator.

4.3.2.2 From the “**Control Panel**”, double-click the “**System**” icon, select the “**Hardware**” tab, and click the “**Device Manager**” button.

4.3.2.3 Expand the “**Computer\Other**” devices. Highlight “**Other PCI Bridge Device**” and click on “**Properties**”.

4.3.2.4 From the “**Properties**” dialog box, click the “**Driver**” tab and click the “**Update Driver**” button. The Update Device Driver Wizard appears. Click “**Next**”.

4.3.2.5 In the “**Update Device Driver Wizard**” window, select “**Display a list of the known drivers for this device**”.

4.3.2.6 Click “**Hard have...**”. Click Specify a location and click “**Browse**” button. Then, navigate to “**F:\ITE8888**” (where “**F**” should be substituted as your CD-drive), and click “**Next**”.

4.3.2.7 Click “**Next**” to accept the updated driver for “**ITE 8888 PCI to ISA bridge**”. Click “**Next**” to continue with driver installation.

4.3.2.8 Follow the instructions on the screen. Click **“Finish”** to complete installation.

Appendix A Memory Approval List

Die Brand & Model Name	Vendor	Capacity
SAMSUNG K4H560838D-TXB0	APACER	512 MB
SAMSUNG K4H280838D-TCB3	APACER	256 MB
SAMSUNG K4H280838D-TXB0	APACER	256 MB
SAMSUNG K4H280838D-TCB3	APACER	128 MB
SAMSUNG K4H5600838D-TCB3	Transcend	512 MB
SAMSUNG K4H5600838D-TCB3	Transcend	256 MB
SAMSUNG K4H280838D-TXB0	ATP	256 MB

Appendix B ISA Add-on Card Approval List

Industrial Card	Brand	Interface
PCL-746-B	Advantech	ISA
PCL-730	Advantech	ISA
CL-104H	MOXA	ISA
CL-132	MOXA	ISA

Appendix C Safety Instructions

C.1 English

1. Read these safety instructions carefully.
2. Keep this user's manual for later reference.
3. Disconnect this equipment from any AC outlet before cleaning. Do not use liquid or spray detergents for cleaning. Use a damp cloth.
4. For pluggable equipment, the power outlet must be installed near the equipment and be easily accessible.
5. Keep this equipment away from humidity
6. Put this equipment on a reliable surface during installation. Dropping it or letting it fall could cause damage.
7. The openings on the enclosure are for air convection. Protect the equipment from overheating. DO NOT COVER THE OPENINGS.
8. Make sure the voltage of the power source is correct before connecting equipment to the power outlet.
9. Position the power cord so that people cannot step on it. Do not place anything over the power cord.
10. All cautions and warnings on the equipment should be noted.
11. If the equipment is not used for a long time, disconnect it from the power source to avoid damage by transient over-voltage.
12. Never pour any liquid into an opening. This could cause fire or electrical shock.
13. Never open the equipment. For safety reasons, the equipment should be opened by qualified service personnel only.

14. If any of the following situations arises, get the equipment checked by service personnel.
- a. The power cord or plug is damaged.
 - b. Liquid has penetrated into the equipment.
 - c. The equipment has been exposed to moisture.
 - d. The equipment does not work well, or you cannot get it to work well according to the installation reference guide.
 - e. The equipment has been dropped and damaged.
 - f. The equipment has obvious signs of breakage.
15. DO NOT LEAVE THIS EQUIPMENT IN AN UNCONTROLLED ENVIRONMENT WHERE THE STORAGE TEMPERATURE IS BELOW -20°C (-4°F) OR ABOVE 60°C (140°F). THIS MAY DAMAGE THE EQUIPMENT.

The sound pressure level at the operator's position according to IEC 704-1; 1982 is equal to or less than 70dB(A).

DISCLAIMER: This set of instructions is given according to IEC 704-1. Advantech disclaims all responsibility for the accuracy of any statements contained herein.

C.2 German- Wichtige Sicherheitshinweise

1. Bitte lesen Sie sich diese Hinweise sorgfältig durch.
2. Heben Sie diese Anleitung für den späteren Gebrauch auf.
3. Vor jedem Reinigen ist das Gerät vom Stromnetz zu trennen. Verwenden Sie keine Flüssig- oder Aerosolreiniger. Am besten dient ein angefeuchtetes Tuch zur Reinigung.
4. Die Netzanschlußsteckdose soll nahe dem Gerät angebracht und leicht zugänglich sein.
5. Das Gerät ist vor Feuchtigkeit zu schützen.
6. Bei der Aufstellung des Gerätes ist auf sicheren Stand zu achten. Ein Kippen oder Fallen könnte Verletzungen hervorrufen.
7. Die Belüftungsöffnungen dienen zur Luftzirkulation die das Gerät vor Überhitzung schützt. Sorgen Sie dafür, daß diese Öffnungen nicht abgedeckt werden.
8. Beachten Sie beim Anschluß an das Stromnetz die Anschlußwerte.
9. Verlegen Sie die Netzanschlußleitung so, daß niemand darüber fallen kann. Es sollte auch nichts auf der Leitung abgestellt werden.
10. Alle Hinweise und Warnungen die sich an Geräten befinden sind zu beachten.
11. Wird das Gerät über einen längeren Zeitraum nicht benutzt, sollten Sie es vom Stromnetz trennen. Somit wird im Falle einer Überspannung eine Beschädigung vermieden.
12. Durch die Lüftungsöffnungen dürfen niemals Gegenstände oder Flüssigkeiten in das Gerät gelangen. Dies könnte einen Brand bzw.

elektrischen Schlag auslösen.

13. Öffnen Sie niemals das Gerät. Das Gerät darf aus Gründen der elektrischen Sicherheit nur von autorisiertem Servicepersonal geöffnet werden.
14. Wenn folgende Situationen auftreten ist das Gerät vom Stromnetz zu trennen und von einer qualifizierten Servicestelle zu überprüfen:
 - a. Netzkabel oder Netzstecker sind beschädigt.
 - b. Flüssigkeit ist in das Gerät eingedrungen.
 - c. Das Gerät war Feuchtigkeit ausgesetzt.
 - d. Wenn das Gerät nicht der Bedienungsanleitung entsprechend funktioniert oder Sie mit Hilfe dieser Anleitung keine Verbesserung erzielen.
 - e. Das Gerät ist gefallen und/oder das Gehäuse ist beschädigt.
 - f. Wenn das Gerät deutliche Anzeichen eines Defektes aufweist.
15. Bitte lassen Sie das Gerät nicht unbehehrt hinten unter -20°C (-4°F) oder oben 60°C (140°F), weil diesen Temperaturen das Gerät zerstören könnten.

Der arbeitsplatzbezogene Schalldruckpegel nach DIN 45 635 Teil 1000 beträgt 70dB(A) oder weniger.

DISCLAIMER: This set of instructions is provided according to IEC 704-1. Advantech disclaims all responsibility for the accuracy of any statements contained herein.