

RIO-3302/RIO-3302S

6U CompactPCI™ Rear Transition card

Copyright Notice

This document is copyrighted, 2001. All rights are reserved. The original manufacturer reserves the right to make improvements to the products described in this manual at any time without notice.

No part of this manual may be reproduced, copied, translated or transmitted in any form or by any means without the prior written permission of the original manufacturer. Information provided in this manual is intended to be accurate and reliable. However, the original manufacturer assumes no responsibility for its use, nor for any infringements upon the rights of third parties which may result from its use.

Acknowledgements

PICMG™, CompactPCI™ and the PICMG™, CompactPCI™ logos are trademarks of the PCI Industrial Computers Manufacturers Group

All other product names or trademarks are properties of their respective owners.

CE Notification

The MIC-3036, developed by Advantech Co., Ltd., has passed the CE test for environment specifications when shielded cables are used for external wiring. We recommend the use of shielded cables.

Part No. 2002330200
Printed in Taiwan

1st Edition
October 2001

Product warranty

Advantech warrants to you, the original purchaser, that each of its products will be free from defects in materials and workmanship for one year from the date of purchase.

This warranty does not apply to any products which have been repaired or altered by persons other than repair personnel authorized by Advantech, or which have been subject to misuse, abuse, accident or improper installation. Advantech assumes no liability under the terms of this warranty as a consequence of such events.

Because of Advantech's high quality-control standards and rigorous testing, most of our customers never need to use our repair service. If an Advantech product is defective, it will be repaired or replaced at no charge during the warranty period. For out-of-warranty repairs, you will be billed according to the cost of replacement materials, service time and freight. Please consult your dealer for more details.

If you think you have a defective product, follow these steps:

1. Collect all the information about the problem encountered. For example, CPU speed, Advantech products used, other hardware and software used, etc. Note anything abnormal and list any on-screen messages you get when the problem occurs.
2. Call your dealer and describe the problem. Please have your manual, product, and any helpful information readily available.
3. If your product is diagnosed as defective, obtain an RMA (return merchandise authorization) number from your dealer. This allows us to process your return more quickly.
4. Carefully pack the defective product, a fully-completed Repair and Replacement Order Card and a photocopy proof of purchase date (such as your sales receipt) in a shippable container. A product returned without proof of the purchase date is not eligible for warranty service.
5. Write the RMA number visibly on the outside of the package and ship it prepaid to your dealer.

Packing List

Before installation, ensure that the following materials have been received:

- One RIO-3302 (or RIO-3302S) CompactPCI™ rear transition card
- One warranty certificate
- One startup Manual
- One CD disc and manual (in PDF format)

If any of these items are missing or damaged, contact your distributor or sales representative immediately.

Technical Support and Sales Assistance

If you have any technical questions about the RIO-3302 (or RIO-3302S) or any other Advantech products, please visit our support website at:

- <http://www.advantech.com.tw/support>

For more information about Advantech's products and sales information, please visit:

- <http://www.advantech.com>

Contents

1. General Information	1
1.1 Introduction	2
1.2 Specification	2
1.2.1 SCSI Function	2
1.2.2 Standard functions	2
1.2.3 Mechanical and environmental specifications	3
1.3. Indicator and Connector Location	4
2. Hardware and drivers Installation	7
2.1 Card installation	8
2.1.1 Card Installation and Removal	8
2.1.2 Driver installation	10
A. Pin Assignments	11
A.1 J1 connector pin assignment (RIO-3302S only)	12
A.2 J2 connector pin assignment (RIO-3302S only)	13
A.3 Pin Assignment	14
A.3.1 J3 Connector Pin Assignment	14
A.3.2 J4 Connector Pin Assignment	15
A.4 RIO-3302S Ultra3 SCSI Connectors (CN50)	16
A.5 VGA Display Connector (CN1)	18
A.6 Keyboard and Mouse Connector (CN8,CN9)	18
A.7 COM1 and COM2 Serial Port (CN12, CN6)	19
A.8 USB Connector (CN3)	20
A.9 Ethernet RJ-45 Connector (CN2,CN4)	20
A.10 CompactFlash Socket (CN14)	21
A.11 Floppy Disk Drive Connector (CN7)	22

A.12 Hard Disk Drive Connector (CN11,CN13)	23
A.13 Hard Disk Drive Connector (CN10)	24

Figures

Figure 1-1: RIO-3302/RIO-3302S connector and jumper locations 4

Figure 2-1: Installing a card into the chassis 9

Tables

Table 1-1: RIO-3302/RIO-3302S connector and jumper descriptions	5
Table A-1: J1 connector pin assignments	12
Table A-2: J2 connector pin assignments	13
Table A-3: J3 Connector Pin Assignment	14
Table A-4: J4 Connector Pin Assignment	15
Table A-5: RIO-3302S Ultra3 SCSI connectors	16
Table A-6: RIO-3302/RIO-3302S CRT display connector	18
Table A-7: RIO-3302/RIO-3302S keyboard and mouse connector	18
Table A-8: RIO-3302/RIO-3302S COM1 and COM2 serial port	19
Table A-9: RIO-3302/RIO-3302S USB1 connector	20
Table A-10: RIO-3302/RIO-3302S Ethernet RJ-45 connector	20
Table A-11: RIO-3302/RIO-3302S CompactFlash socket	21
Table A-12: Floppy Disk Drive Connector	22
Table A-13: Hard Disk Drive Connector	23
Table A-14: Hard Disk Drive Connector	24

CHAPTER

1

General Information

1.1 Introduction

The RIO-3302/RIO-3302S is a CompactPCI 6U-sized rear transition board. It provides access to the rear panel for the I/O function on Advantech's CompactPCI CPU board.

1.2 Specification

1.2.1 SCSI Function

- **Controller** : Adaptec AIC-7892™
- **Bus** : PCI 64-bit / 33Mhz
- **Channel** : single SCSI channel
- **Data transfer rate** : The data channel DMA engine in the AIC-7892 supports data transfer rates upto 160MB/s on a wide(16-bit) SCSI using LVD SCSI I/Os.
- **Termination** : On-board terminators provided

1.2.2 Standard functions

- **Ethernet**: Two LAN ports with RJ-45 connectors
- **VGA connector**: One DB-15 VGA connector
- **Serial port**: Two DB-9 RS-232 ports
- **USB interface**: One USB connectors

- **EIDE interface:** Two connectors for IDE channels(Primary and Secondary channels)
- **FDD interface:** Supports one on-board slim-type floppy connector.
- **CompactFlash™ interface:** Supports one on-board CompactFlash™ socket
- **Keyboard connector:** One 6-pin mini-DIN connector on rear panel
- **Mouse connector:** One 6-pin mini-DIN connector on rear panel

1.2.3 Mechanical and environmental specifications

- **Board size:** 233.35 x 80 mm (6U), one slot (4TE) wide
- **Max. power requirements:** +5 V (4.75 ~ 5.25 V) @ 1 A
- **Operating temperature:** 0 ~ 60 °C (32 ~ 140 °F)
- **Storage temperature:** -20 ~ 70 °C (-4 ~ 158 °F)
- **Humidity (operating and storage):** 5 ~ 95% (non-condensing)
- **Board weight:** 0.8 Kg
- **Shock:** 20 G (operating); 50 G (storage/transit)
- **Random vibration:** 5~500Mhz Operating: 1.5Grms Non-operating: 2Grms

1.3. Indicator and Connector Location

The RIO-3302/RIO-3302S provides jumpers and connectors for users specific applications.

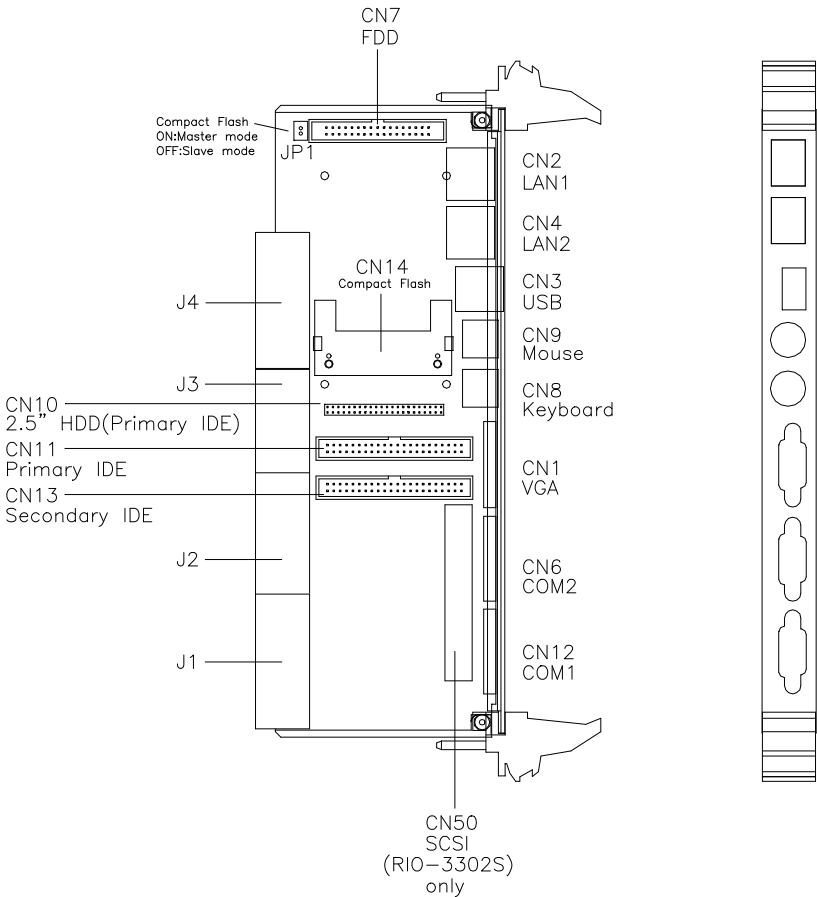

Figure 1-1: RIO-3302/RIO-3302S connector and jumper locations

Table 1-1: RIO-3302/RIO-3302S connector and jumper descriptions

Number	Function
JP1	CompactFlash™ master/slave selection
CN1	VGA connector
CN2	LAN 1 connector
CN3	USB 1 connector
CN4	LAN 2 connector
CN6	COM2 port
CN7	Floppy disk connector
CN8	PS/2 keyboard connector
CN9	PS/2 mouse connector
CN10	44-pin IDE channel-1 connector
CN11	IDE channel-1 connector
CN12	COM1 port
CN13	IDE channel-2 connector
CN14	50-pin CompactFlash™ connector
CN50	SCSI internal connector (RIO-3302S only)

Note:

The CompactFlash interface (CN14) uses a primary IDE channel. Users need to set it as master or slave via jumper JP1 when another device is connected on the primary IDE channel as

CHAPTER
2

**Hardware and drivers
Installation**

2.1 Card installation

2.1.1 Card Installation and Removal

The CompactPCI™ connectors are firm and rigid, and require careful handling while plugging and unplugging. Improper installation of a card can easily damage the backplane of the chassis.

The system card can be installed only in the system slot. Do not insert the system card into the other slot, or insert a peripheral card into the system slot. The system slot is marked by a triangle enclosing the slot number. Please refer to chapter3

Note: Another easy way to distinguish the system slot is that the system slot uses red guide rails while the peripheral slots use gray ones.

The insert/eject handles on CompactPCI™ cards help users to install and remove the cards easily and safely. Follow the procedures below to install a card into a chassis:

To install a card:

1. Hold the card horizontally. Be sure that the card is oriented correctly. The components of the card should be pointing to the upper side.
2. Be sure that the handles of the card are not latched. Release the handles if they are latched. Handles from different vendors may have different latch designs.

Caution: Keep your fingers away from the latch hinges to prevent your fingers from getting pinched.

3. Insert the card into the chassis by sliding the both edges of the card into the card guides.
4. Push the card into the slot gently by sliding the card along the card guide rails until the handles meet the rectangular holes of the handle locker rails.

Note: If the card is correctly positioned and has been slid

all the way into the chassis, the handles should match the rectangular holes. If not, remove the card from the card guide and repeat step 3 again. Do not try to install a card by forcing it into the chassis.

5. Left-pull the right handle and right-pull the left handle to push the card into place.
6. Secure the card by locking the handles into place.

To remove a card:

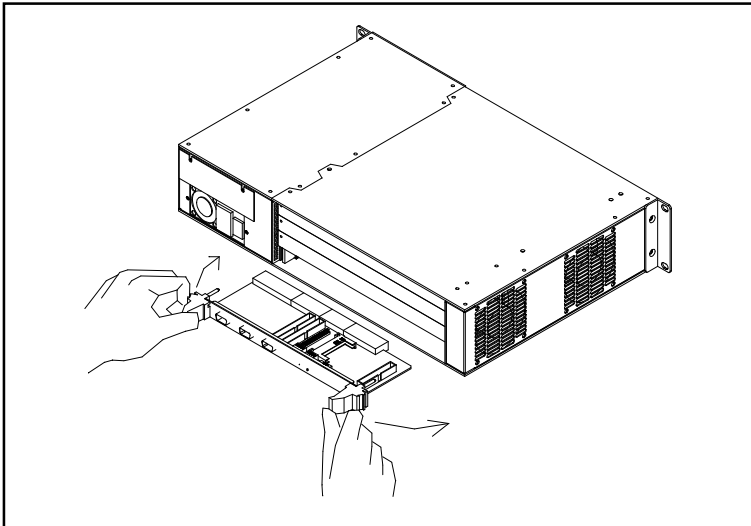

Figure 2-1: Installing a card into the chassis

1. Release the locking latches on the handles.
2. Push the both handles out to release the card from the backplane.
3. Slide the card out.

2.1.2 Driver installation

Device drivers and utilities for DOS, Windows2000/95/98/NT and SCO UNIX are included in the utility CD-ROM disc.

The utility user's guide and installation instructions are provided in the utility CD-ROM disc. The instructions are located in the directory \RIO3302S\SCSI.

APPENDIX

A

Pin Assignments

A.1 J1 connector pin assignment (RIO-3302S only)

Table A-1: J1 connector pin assignments

Pin	Row A	Row B	Row C	Row D	Row E
25	+5 V	REQ64#	N/C	N/C	+5 V
24	AD1	+5 V	N/C	AD0	ACK64#
23	N/C	AD4	AD3	+5 V	AD2
22	AD7	GND	N/C	AD6	AD5
21	N/C	AD9	AD8	M66EN	C/BE0#
20	AD12	GND	N/C	AD11	AD10
19	N/C	AD15	AD14	GND	AD13
18	SERR#	GND	N/C	PAR	C/BE1#
17	N/C	N/C	N/C	GND	PERR#
16	DEVSEL#	GND	N/C	STOP#	N/C
15	N/C	FRAME#	IRDY#	GND	TRDY#
14					
13	KEY	AREA			
12					
11	AD18	AD17	AD16	GND	C/BE2#
10	AD21	GND	N/C	AD20	AD19
9	C/BE3#	IDSEL	AD23	GND	AD22
8	AD26	GND	N/C	AD25	AD24
7	AD30	AD29	AD28	GND	AD27
6	REQ#	GND	N/C	CLK	AD31
5	N/C	N/C	RST#	GND	GNT#
4	N/C	GND	N/C	N/C	N/C
3	INTA#	N/C	N/C	+5 V	N/C
2	N/C	+5 V	N/C	N/C	N/C
1	+5 V	N/C	TRST#	+12 V	+5 V

indicates "low active".

A.2 J2 connector pin assignment (RIO-3302S only)

Table A-2: J2 connector pin assignments

Pin	Row A	Row B	Row C	Row D	Row E
22	N/C	N/C	N/C	N/C	N/C
21	N/C	GND	N/C	N/C	N/C
20	N/C	N/C	N/C	GND	N/C
19	N/C	GND	N/C	N/C	N/C
18	N/C	N/C	N/C	GND	N/C
17	N/C	GND	N/C	N/C	N/C
16	N/C	N/C	N/C	GND	N/C
15	N/C	GND	N/C	N/C	N/C
14	AD35	AD34	AD33	GND	AD32
13	AD38	GND	N/C	AD37	AD36
12	AD42	AD41	AD40	GND	AD39
11	AD45	GND	N/C	AD44	AD43
10	AD39	AD48	AD47	GND	AD46
9	AD52	GND	N/C	AD51	AD50
8	AD56	AD55	AD54	GND	AD53
7	AD59	GND	N/C	AD58	AD57
6	AD63	AD62	AD61	GND	AD60
5	C/BE5#	GND	N/C	C/BE4#	PAR64#
4	N/C	N/C	C/BE7#	GND	C/BE6#
3	N/C	GND	N/C	N/C	N/C
2	N/C	N/C	N/C	N/C	N/C
1	N/C	GND	N/C	N/C	N/C

indicates "low active".

A.3 Pin Assignment

A.3.1 J3 Connector Pin Assignment

Table A-3: J3 Connector Pin Assignment

Pin	Row A	Row B	Row C	Row D	Row E
19	SID3	SID6	SID2	SID10	SID14
18	SID8	SID5	SID1	SID11	SID15
17	SID9	SID4	SID0	SID12	SID13
16	SID7	SCS1#	SIOR#	SCS3#	SRDY
15	SDRQ#	SACK#	SDA2	SIRQ	SIOW
14	NRTS1	NDSR1	SDA1	GND	SDA0
13	NRI1	NCTS1	NTX1	NRX1	NRLSD1
12	PID0	PID2	PID4	PID7	NDTR1
11	PID1	PID3	PID8	PID6	PID12
10	PID5	PID9	PID10	PID11	PID13
9	PID15	PID14	PDRQ#	PCS3#	PIOR#
8	PIRQ	PACK#	+5V	PDA2	PIOW#
7	N/C	GND	PRST#	PRDY	PCS1#
6	N/C	+5V	GND	PDA0	PDA1
5	+5V	N/C	S66DET	N/C	N/C
4	KDAT	KCLK	MDAT	MCLK	P66DET
3	DSKCHG#	MOA#	STEP#	HEAD#	TRAK0
2	DSA#	MOB#	RWC#	RDATA#	WP#
1	INDEX#	DSB#	DIR#	WE#	WD#

#: Low active

Note:

The RIO-3302 supports DMA/66 HDD.

A.3.2 J4 Connector Pin Assignment

Table A-4 : J4 Connector Pin Assignment

Pin	Row A	Row B	Row C	Row D	Row E
25	LanTx2-	LanTx1-	USBV1	USBV0	USBD1+
24	LanTx2+	LanTx1+	N/C	USBD1-	USBD0-
23	GND	GND	N/C	N/C	USBD0+
22	LanRx2-	LanRx1-	N/C	N/C	NDTR2
21	LanRx2+	LanRx+	N/C	N/C	NRTS2
20	GND	GND	N/C	N/C	NCTS2
19	N/C	N/C	N/C	N/C	NTX2
18	N/C	N/C	N/C	N/C	NRLSD2
17	N/C	N/C	N/C	N/C	NDSR2
16	N/C	N/C	N/C	N/C	NRI2
15	N/C	N/C	N/C	N/C	NRX2
12-14	Key Area				
11	+5V	N/C	N/C	N/C	N/C
10	+5V	N/C	N/C	N/C	N/C
9	+5V	N/C	N/C	N/C	N/C
8	+5V	N/C	N/C	N/C	N/C
7	N/C	N/C	N/C	N/C	N/C
6	N/C	N/C	N/C	N/C	N/C
5	N/C	N/C	N/C	N/C	N/C
4	N/C	N/C	N/C	VSYNC	N/C
3	N/C	N/C	HSYNC	N/C	N/C
2	BLUE	GREEN	RED	N/C	N/C
1	N/C	N/C	N/C	N/C	N/C

A.4 RIO-3302S Ultra3 SCSI Connectors (CN50)

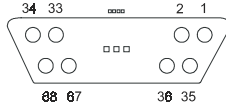

Table A-5: RIO-3302S Ultra3 SCSI connectors

Pin	Signal	Pin	Signal
1	+ASD12	35	-ASD12
2	+ASD13	36	-ASD13
3	+ASD14	37	-ASD14
4	+ASD15	38	-ASD15
5	+ASDP1	39	-ASDP1
6	+ASD0	40	-ASD0
7	+ASD1	41	-ASD1
8	+ASD2	42	-ASD2
9	+ASD3	43	-ASD3
10	+ASD4	44	-ASD4
11	+ASD5	45	-ASD5
12	+ASD6	46	-ASD6
13	+ASD7	47	-ASD7
14	+ASDP0	48	-ASDP0
15	GND	49	GND
16	DIFFSEN-A	50	ASEN-IN FOR J6 ASEN-EX FOR J4
17	A-TPWE	51	A-TPWE
18	A-TPWE	52	A-TPWE
19	N/C	53	N/C
20	GND	54	GND
21	+ASATN	55	-ASATN

22	GND	56	GND
23	+ASBSY	57	-ASBSY
24	+ASACK	58	-ASACK
25	+ASRST	59	-ASRST
26	+ASMSG	60	-ASMSG
27	+ASSEL	61	-ASSEL
28	+ASCD	62	-ASCD
29	+ASREQ	63	-ASREQ
30	+ASIO	64	-ASIO
31	+ASD8	65	-ASD8
32	+ASD9	66	-ASD9
33	+ASD10	67	-ASD10
34	+ASD11	68	-ASD11

A.5 VGA Display Connector (CN1)

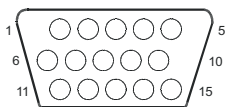

Table A-6: RIO-3302/RIO-3302S CRT display connector

Pin	Signal	Pin	Signal
1	RED	9	VGAVCC
2	GREEN	10	GND
3	BLUE	11	N/C
4	N/C	12	SDA
5	GND	13	HSYNC
6	GND	14	VSYNC
7	GND	15	SCL
8	GND		

A.6 Keyboard and Mouse Connector (CN8,CN9)

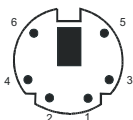

Table A-7: RIO-3302/RIO-3302S keyboard and mouse connector

Pin	Keyboard	Mouse
1	KDAT	MDAT
2	GND	GND
3	VCC	VCC
4	KCLK	MCLK
5	N/C	N/C
6	N/C	N/C

A.7 COM1 and COM2 Serial Port (CN12, CN6)

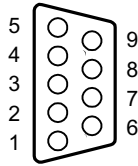

Table A-8: RIO-3302/RIO-3302S COM1 and COM2 serial port

Pin	COM1 Signal	Pin	COM2 Signal
1	NRLSD1	1	NRLSD2
2	NRX1	2	NRX2
3	NTX1	3	NTX2
4	NDTR1	4	NDTR2
5	GND	5	GND
6	NDSR1	6	NDSR2
7	NRTS1	7	NRTS2
8	NCTS1	8	NCTS2
9	NRI1	9	NRI2

A.8 USB Connector (CN3)

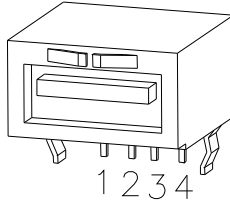

Table A-9: RIO-3302/RIO-3302S USB1 connector

Pin	USB1 Signal
1	VCC
2	USBD0-
3	USBD0+
4	GND

A.9 Ethernet RJ-45 Connector (CN2,CN4)

Table A-10: RIO-3302/RIO-3302S Ethernet RJ-45 connector

Pin	Signal	Lan2 (CN4)
1	TX+	TX2+
2	TX-	TX-
3	RX+	RX+
4	N/C	N/C
5	N/C	N/C
6	RX-	RX-
7	N/C	N/C
8	N/C	N/C

A.10 CompactFlash Socket (CN14)

Table A-11: RIO-3302/RIO-3302S CompactFlash socket

Pin	Signal	Pin	Signal
1	GND	26	N/C
2	PID3	27	PID11
3	PID4	28	PID12
4	PID5	29	PID13
5	PID6	30	PID14
6	PID7	31	PID15
7	PCS1#	32	PCS3#
8	GND	33	N/C
9	GND	34	PIOR#
10	GND	35	PIOW#
11	GND	36	N/C
12	GND	37	PIRQ
13	VCC	38	VCC
14	GND	39	SANDISK
15	GND	40	N/C
16	GND	41	PRST#
17	GND	42	PRDY
18	PDA2	43	N/C
19	PDA1	44	N/C
20	PDA0	45	PLED
21	PID0	46	N/C
22	PID1	47	PID8
23	PID2	48	PID9
24	N/C	49	PID10
25	N/C	50	GND

A.11 Floppy Disk Drive Connector (CN7)

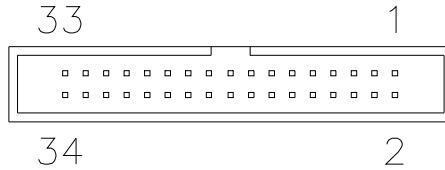

Table A-12: Floppy Disk Drive Connector

Pin	Signal	Pin	Signal
1	PRST#	2	GND
3	PID7	4	PID8
5	PID6	6	PID9
7	PID5	8	PID10
9	PID4	10	PID11
11	PID3	12	PID12
13	PID2	14	PID13
15	PID1	16	PID14
17	PID0	18	PID15
19	GND	20	N/C
21	PDRQ#	22	GND
23	PIOW#	24	GND
25	PIOR#	26	GND
27	PRDY	28	Pull low
29	PACK#	30	GND
31	PIRQ	32	N/C
33	PDA1	34	Pull low
35	PDA0	36	PDA2
37	PCS1#	38	PCS3#
39	HDD_LED	40	GND

low active

A.12 Hard Disk Drive Connector (CN11,CN13)

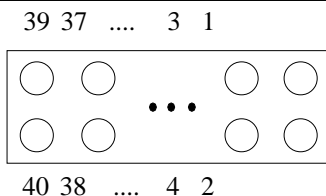

Table A-13: Hard Disk Drive Connector

Pin	Signal	Pin	Signal
1	PRST#	2	GND
3	PID7	4	PID8
5	PID6	6	PID9
7	PID5	8	PID10
9	PID4	10	PID11
11	PID3	12	PID12
13	PID2	14	PID13
15	PID1	16	PID14
17	PID0	18	PID15
19	GND	20	N/C
21	PDRQ#	22	GND
23	PIOW#	24	GND
25	PIOR#	26	GND
27	PRDY	28	Pull low
29	PACK#	30	GND
31	PIRQ	32	N/C
33	PDA1	34	Pull low
35	PDA0	36	PDA2
37	PCS1#	38	PCS3#
39	HDD_LED	40	GND

low active

A.13 Hard Disk Drive Connector (CN10)

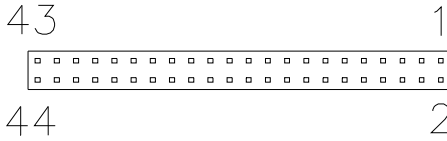

Table A-14: Hard Disk Drive Connector

Pin	Signal	Pin	Signal
1	PRST#	2	GND
3	PID7	4	PID8
5	PID6	6	PID9
7	PID5	8	PID10
9	PID4	10	PID11
11	PID3	12	PID12
13	PID2	14	PID13
15	PID1	16	PID14
17	PID0	18	PID15
19	GND	20	N/C
21	PDRQ#	22	GND
23	PIOW#	24	GND
25	PIOR#	26	GND
27	PRDY	28	Pull low
29	PACK#	30	GND
31	PIRQ	32	N/C
33	PDA1	34	Pull low
35	PDA0	36	PDA2
37	PCS1#	38	PCS3#
39	HDD_LED	40	GND

low active