

POC-153

**Pentium® III processor-based
Point-of-Care Terminal with 15"
LCD flat panel display**

Users Manual

Copyright

This document is copyrighted, © 2003. All rights are reserved. The original manufacturer reserves the right to make improvements to the products described in this manual at any time without notice.

No part of this manual may be reproduced, copied, translated or transmitted in any form or by any means without the prior written permission of the original manufacturer. Information provided in this manual is intended to be accurate and reliable. However, the original manufacturer assumes no responsibility for its use, nor for any infringements upon the rights of third parties that may result from such use.

Acknowledgements

Award is a trademark of Award Software International, Inc.

VIA is a trademark of VIA Technologies, Inc.

IBM, PC/AT, PS/2 and VGA are trademarks of International Business Machines Corporation.

Intel and Pentium are trademarks of Intel Corporation.

Microsoft Windows® is a registered trademark of Microsoft Corp.

RTL is a trademark of Realtek Semi-Conductor Co., Ltd.

ESS is a trademark of ESS Technology, Inc.

UMC is a trademark of United Microelectronics Corporation.

SMI is a trademark of Silicon Motion, Inc.

Creative is a trademark of Creative Technology LTD.

All other product names or trademarks are properties of their respective owners.

For more information on this and other Advantech products, please visit our websites at: **<http://www.advantech.com>**

<http://www.advantech.com/eHealthcare>

For technical support and service, please visit our support website at:

<http://support.advantech.com>

This manual is for the POC-153.

Part No. 2008015330

1st Edition, Printed in Taiwan Aug. 2003

FCC Class B

This equipment has been tested and found to comply with the limits for a Class B digital device, pursuant to Part 15 of the FCC Rules. These limits are designed to provide reasonable protection against harmful interference when the equipment is operated in a residential environment. This equipment generates, uses and can radiate radio frequency energy. If not installed and used in accordance with this user's manual, it may cause harmful interference to radio communications. Note that even when this equipment is installed and used in accordance with this user's manual, there is still no guarantee that interference will not occur. If this equipment is believed to be causing harmful interference to radio or television reception, this can be determined by turning the equipment on and off. If interference is occurring, the user is encouraged to try to correct the interference by one or more of the following measures:

- Reorient or relocate the receiving antenna
- Increase the separation between the equipment and the receiver
- Connect the equipment to a power outlet on a circuit different from that to which the receiver is connected
- Consult the dealer or an experienced radio/TV technician for help

Warning! *Any changes or modifications made to the equipment which are not expressly approved by the relevant standards authority could void your authority to operate the equipment.*



Packing List

Before you begin installing your card, please make sure that the following materials have been shipped:

- POC-153 series panel PC
- Accessories for POC-153
 - Y-shaped adapter for PS/2 mouse and keyboard
 - Power cord (1.8 m) - USA type (other types are available on request)
 - Floppy disk with CD-ROM drive driver
 - "Drivers and Utilities" CD-ROM disc
 - Mounting kits and packet of screws

Heat sink (optional) (refer to Notes 1 and 2 below)

If any of these items are missing or damaged, contact your distributor or sales representative immediately.

Note1: If the unit you have bought is basic (i.e. without a CPU, HDD, or SDRAM), you will find this optional item in the accessory box.

Note2: If you install an Intel® processor yourself, you must install a heat sink above the CPU. This will avoid heat damage to the CPU.

Additional Information and Assistance

- Step 1. Visit the Advantech web site at **www.advantech.com** where you can find the latest information about the product.
- Step 2. Contact your distributor, sales representative, or Advantech's customer service center for technical support if you need additional assistance. Please have the following information ready before you call:
- Product name and serial number
 - Description of your peripheral attachments
 - Description of your software (operating system, version, application software, etc.)
 - A complete description of the problem
 - The exact wording of any error messages

Warning! 1. *Input voltage rated 100-250 V_{AC}, 50/60 Hz, 3 A*



2. *Use a 3 V @ 195 mA lithium battery*
3. *Packing: please carry the unit with both hands, handle with care*
4. *Maintenance: to properly maintain and clean the surfaces, use only approved products or clean with a dry applicator*
5. *CompactFlash: Turn off power before inserting or removing CompactFlash storage card.*

Contact information:

Our European representative:
Advantech Europe GmbH
Kolberger Straße 7
D-40599 Düsseldorf, Germany
Tel: 49-211-97477350
Fax: 49-211-97477300

Safety Instructions

1. Read these safety instructions carefully.
2. Keep this User's Manual for later reference.
3. Disconnect this equipment from any AC outlet before cleaning. Use a damp cloth. Do not use liquid or spray detergents for cleaning.
4. For plug-in equipment, the power outlet socket must be located near the equipment and must be easily accessible.
5. Keep this equipment away from humidity.
6. Put this equipment on a reliable surface during installation. Dropping it or letting it fall may cause damage.
7. The openings on the enclosure are for air convection. Protect the equipment from overheating. **DO NOT COVER THE OPENINGS.**
8. Make sure the voltage of the power source is correct before connecting the equipment to the power outlet.
9. Position the power cord so that people cannot step on it. Do not place anything over the power cord.
10. All cautions and warnings on the equipment should be noted.
11. If the equipment is not used for a long time, disconnect it from the power source to avoid damage by transient overvoltage.
12. Never pour any liquid into an opening. This may cause fire or electrical shock.
13. Never open the equipment. For safety reasons, the equipment should be opened only by qualified service personnel.
14. If one of the following situations arises, get the equipment checked by service personnel:
 - a. The power cord or plug is damaged.
 - b. Liquid has penetrated into the equipment.
 - c. The equipment has been exposed to moisture.
 - d. The equipment does not work well, or you cannot get it to work according to the user's manual.
 - e. The equipment has been dropped and damaged.
 - f. The equipment has obvious signs of breakage.
15. **DO NOT LEAVE THIS EQUIPMENT IN AN ENVIRONMENT WHERE THE STORAGE TEMPERATURE MAY GO BELOW -20° C (-4° F) OR ABOVE 60° C (140° F). THIS COULD DAMAGE THE EQUIPMENT. THE EQUIPMENT SHOULD BE IN A CONTROLLED ENVIRONMENT.**
16. **CAUTION: DANGER OF EXPLOSION IF BATTERY IS INCORRECTLY REPLACED. REPLACE ONLY WITH THE SAME OR EQUIVALENT TYPE RECOMMENDED BY THE MANUFACTURER, DISCARD USED BATTERIES ACCORDING TO THE MANUFACTURER'S INSTRUCTIONS.**

The sound pressure level at the operator's position according to IEC 704-1:1982 is no more than 70 dB (A).

DISCLAIMER: This set of instructions is given according to IEC 704-1. Advantech disclaims all responsibility for the accuracy of any statements contained herein.

Wichtige Sicherheitshinweise

1. Bitte lesen sie Sich diese Hinweise sorgfältig durch.
2. Heben Sie diese Anleitung für den späteren Gebrauch auf.
3. Vor jedem Reinigen ist das Gerät vom Stromnetz zu trennen. Verwenden Sie Keine Flüssig-oder Aerosolreiniger. Am besten dient ein angefeuchtetes Tuch zur Reinigung.
4. Die Netzanschlussteckdose soll nahe dem Gerät angebracht und leicht zugänglich sein.
5. Das Gerät ist vor Feuchtigkeit zu schützen.
6. Bei der Aufstellung des Gerätes ist auf sicheren Stand zu achten. Ein Kippen oder Fallen könnte Verletzungen hervorrufen.
7. Die Belüftungsöffnungen dienen zur Luftzirkulation die das Gerät vor überhitzung schützt. Sorgen Sie dafür, daß diese Öffnungen nicht abgedeckt werden.
8. Beachten Sie beim Anschluß an das Stromnetz die Anschlußwerte.
9. Verlegen Sie die Netzanschlusbleitung so, daß niemand darüber fallen kann. Es sollte auch nichts auf der Leitung abgestellt werden.
10. Alle Hinweise und Warnungen die sich am Geräten befinden sind zu beachten.
11. Wird das Gerät über einen längeren Zeitraum nicht benutzt, sollten Sie es vom Stromnetz trennen. Somit wird im Falle einer Überspannung eine Beschädigung vermieden.
12. Durch die Lüftungsöffnungen dürfen niemals Gegenstände oder Flüssigkeiten in das Gerät gelangen. Dies könnte einen Brand bzw. elektrischen Schlag auslösen.
13. Öffnen Sie niemals das Gerät. Das Gerät darf aus Gründen der elektrischen Sicherheit nur von autorisiertem Servicepersonal geöffnet werden.
14. Wenn folgende Situationen auftreten ist das Gerät vom Stromnetz zu trennen und von einer qualifizierten Servicestelle zu überprüfen:
 - a - Netzkabel oder Netzstecker sind beschädigt.
 - b - Flüssigkeit ist in das Gerät eingedrungen.
 - c - Das Gerät war Feuchtigkeit ausgesetzt.
 - d - Wenn das Gerät nicht der Bedienungsanleitung entsprechend funktioniert oder Sie mit Hilfe dieser Anleitung keine Verbesserung erzielen.
 - e - Das Gerät ist gefallen und/oder das Gehäuse ist beschädigt.
 - f - Wenn das Gerät deutliche Anzeichen eines Defektes aufweist.
15. VORSICHT: Explosionsgefahr bei unsachgemabem Austausch der Batterie.Ersatz nur durch denselben oder einem vom Hersteller empfohlene-mahnlichen Typ. Entsorgung gebrauchter Batterien navh Angaben des Herstellers.

Der arbeitsplatzbezogene Schalldruckpegel nach DIN 45 635 Teil 1000 beträgt 70dB(A) oder weiger.

DISCLAIMER: This set of instructions is given according to IEC704-1. Advantech disclaims all responsibility for the accuracy of any statements contained herein.

 **CAUTION!**

Danger of explosion if battery is incorrectly replaced.

Replace only with the same or equivalent type
recommended by the manufacturer.
Dispose of used batteries according
to the manufacturer's instructions.

Contents

Chapter 1	General Information	2
1.1	Introduction	2
	Figure 1.1:The POC-153 in perspective	3
1.2	How to use this manual	4
	Figure 1.2:How to read the POC-153 manual	5
1.3	Specifications	6
1.4	Dimensions.....	10
	Figure 1.3:Dimensions of the POC-153	10
Chapter 2	System Setup.....	12
2.1	A Quick Tour of the Panel PC	12
	Figure 2.1:Front view of POC-153 panel PC	12
	Figure 2.2:Left side view of POC-153.....	13
	Figure 2.3:Rear view of POC-153	14
	Figure 2.4:Rear and side view of POC-153.....	14
2.2	Preparing for First-time Use.....	15
2.3	Installation Procedures	15
2.3.1	Connecting the power cord	15
	Figure 2.5:Connecting the power cord	15
2.3.2	Installing the DC power insulator with hood.....	16
2.3.3	Connecting the keyboard and mouse.....	19
	Figure 2.6:Connecting the keyboard and mouse	19
2.3.4	Switching on the power	19
2.4	Running the BIOS Setup Program	20
2.5	Installing System Software.....	21
2.6	Installing the Drivers.....	22
Chapter 3	Using the Panel PC.....	26
3.1	Introduction	26
3.2	Floppy drive	26
	Figure 3.1:Inserting and ejecting a floppy disk	26
3.3	CD-ROM Drive.....	27
	Figure 3.2:Inserting and ejecting a CD-ROM	27
3.4	PCMCIA.....	28
	Figure 3.3:Inserting and ejecting a PCMCIA card	28
	Figure 3.4:I/O interface (excluding COM ports).....	29
	Figure 3.5:I/O interface (excluding COM ports).....	29
3.5	PS/2 Mouse and Keyboard.....	30
3.6	PCI/ISA Bus Expansion	30
	Figure 3.6:PCI/ISA bus expansion	31
3.7	Parallel port	32

3.8	Serial COM ports	32
3.9	VGA Port.....	33
3.10	Game Port.....	33
3.11	USB Ports.....	33
3.12	Audio Interface.....	34
3.13	Ethernet	34
3.14	Adjusting the LCD Contrast and Brightness.....	34
3.15	Touchscreen (Optional).....	35
Chapter 4	Hardware Installation and Upgrade	38
4.1	Jumpers and Connectors.....	38
4.2	Disassembling the Panel PC.....	38
	Figure 4.1:Disassembling rear cover of POC-153.....	39
4.3	Installing the 2.5" Hard Disk Drive (HDD)	40
	Figure 4.2:Installing the primary 2.5" HDD.....	40
4.4	Installing the Central Processing Unit (CPU)	41
	Figure 4.3:Installing the CPU	43
4.5	Installing the SDRAM Memory Module	44
	Figure 4.4:Installing SDRAM.....	44
4.6	Installing FDD and Slim CD-ROM Drive	45
	Figure 4.5:Installing FDD and slim CD-ROM drive....	46
Chapter 5	Jumper Settings & Connectors	48
5.1	Jumpers and Connectors.....	48
5.1.1	Setting jumpers	48
5.1.2	Jumpers and switch.....	49
	Table 5.1:Jumpers and their functions.....	49
5.1.3	Connectors	50
	Figure 5.1:Jumpers on the POC-153 motherboard	50
	Table 5.2:POC-153 connectors.....	51
5.1.4	Locating connectors.....	52
	Figure 5.2:Connectors on POC-153 motherboard	52
5.2	CPU Installation	53
5.3	CMOS Clear for External RTC (JP4)	53
	Table 5.3:CMOS clear (JP4).....	53
5.4	COM-port interface (JP6).....	54
5.4.1	COM2 RS-232/422/485 setting (JP6).....	54
	Table 5.4:COM2 RS-232/422/485 setting (JP6).....	54
	Table 5.5:Serial port default settings	55
5.4.2	COM1/2/3/4 pin 9 output setting (J12, J13, J14).....	56
	Table 5.6:COM1/2/3/4 pin 9 settings (JP12,13,14).....	56
5.5	VGA interface	57
5.5.1	LCD panel power setting.....	57
5.6	Watchdog Timer Configuration (JP3).....	57
	Table 5.7:Watchdog activity selection (JP3).....	57

	5.7	Wake on LAN select (JP2).....	58
		Table 5.8:Wake-on-LAN select (JP2)	58
	5.8	Internal -12 V Source Selection Setting (JP1)	58
		Table 5.9:Internal -12 V source selection setting (JP1)	58
Chapter	6	VIA Chipset	60
	6.1	Introduction	60
	6.2	Driver Installation	60
		6.2.1 Installation for Windows 98/NT/2000/ME.....	61
	6.3	Further Information	65
Chapter	7	PCI Bus Ethernet Interface.....	68
	7.1	Introduction	68
	7.2	Installation of Ethernet Driver.....	68
		7.2.1 Installation for Windows 98/NT/ME/2000.....	69
	7.3	Further Information	72
Chapter	8	VGA Setup	74
	8.1	Introduction	74
		8.1.1 Chipset	74
		8.1.2 Display memory.....	74
		8.1.3 Display types.....	74
	8.2	Installation of the VGA Driver.....	75
		8.2.1 Installation for Windows 95/98/ME	75
		8.2.2 Installation for Windows NT	77
	8.3	Further Information	78
Chapter	9	Audio Setup.....	80
	9.1	Introduction	80
	9.2	Installation of the Audio Driver	80
		9.2.1 Installation for Windows 98/ME/2000/XP	81
Chapter	10	PCMCIA	84
	10.1	Introduction	84
	10.2	Installation of PCMCIA Driver.....	84
		10.2.1 Installation for Windows 95	85
Chapter	11	Touchscreen	88
	11.1	Introduction	88
		11.1.1 General information.....	88
		11.1.2 General specifications.....	89
		11.1.3 Environmental specifications.....	89
	11.2	Driver for Resistive or SAW Touchscreen	90
		11.2.1 Installation for Windows 95/98/Me.....	91
Chapter	12	Award BIOS Setup.....	98
	12.1	Award BIOS Setup.....	98
	12.2	CMOS Setup Utility.....	98

12.2.1	Standard CMOS Setup.....	99
	Figure 12.1:Standard CMOS features.....	99
	Figure 12.2:Standard CMOS features.....	100
12.3	Advanced BIOS Features.....	102
12.4	Advanced Chipset Features.....	106
12.5	Integrated Peripherals.....	109
12.6	Power Management Setup.....	113
12.7	PnP/PCI Configuration.....	117
12.8	PC Health Status.....	119
12.9	Frequency/Voltage Control.....	120
12.10	Load Optimized Defaults.....	120
12.11	Set Password.....	121
12.12	Save & Exit Setup.....	122
12.13	Exit Without Saving.....	122
Appendix A	LCD Specifications.....	124
A.1	POC-153T LCD Specifications.....	124
Appendix B	Programming the Watchdog Timer.....	126
B.1	Programming the Watchdog Timer.....	126
Appendix C	Full Disassembly Procedures.....	130
	Figure C.1:Disassembly steps 1 - 4.....	131
	Figure C.2:Disassembly steps 5 - 6.....	133
	Figure C.3:Disassembly steps 7 - 12.....	135
Appendix D	Pin Assignments.....	138
D.1	AT Power connector (J1).....	138
	Table D.1:Table D-1: AT power connector (J1).....	138
D.2	TV Output Connector (J11) (*Reserved).....	138
	Table D.2:Table D-2: TV output connector (J11).....	138
D.3	Inverter Power Connector (J4).....	139
	Table D.3:Inverter power connector (J4).....	139
D.4	Internal Speaker Connector (J6) (*Reserved).....	139
	Table D.4:Internal speaker connector (J6).....	139
D.5	Front Panel Control Connector (J8) (*Reserved).....	140
	Table D.5:Front panel control connector (J8).....	140
D.6	IR Connector (J9) (*Reserved).....	140
	Table D.6:IR connector (J9) (Reserved).....	140
D.7	Flat Panel Display Connector (CN2).....	141
	Table D.7:Flat panel display connector (CN2).....	141
D.8	Flat Panel Display Connector (CN3).....	142
	Table D.8:Flat panel display connector (CN3).....	142
D.9	Floppy Drive Connector (CN10).....	143
	Table D.9:Floppy drive connector (CN10).....	143
D.10	EIDE Hard Disk Drive Connector (CN16).....	144

	Table D.10:EIDE hard disk drive connector (CN16) .	144
D.11	CD-ROM Connector (CN18)	145
	Table D.11:CD-ROM connector (CN18)	145
D.12	CPU Fan Power Connector (FAN1).....	146
	Table D.12:CPU fan power connector (FAN1).....	146
D.13	Fan power connector (FAN2)	146
	Table D.13:Fan power connector (FAN2).....	146
D.14	PCI/ISA Bus Expansion Connector (SLOT1).....	147
	Table D.14:PCI/ISA pin assignments (Pins A & B)...	148
	Table D.15:PCI/ISA pin assignments (Pins C & D)...	149
	Table D.16:PCI/ISA pin assignments (Pins E & F)...	150
	Table D.17:PCI/ISA pin assignments (Pins G & H) ..	151
D.15	Touchscreen Connector (CN23).....	152
	Table D.18:Internal COM4 and PS/2 Conn. (CN23)..	152
D.16	USB3 Connector (JP7).....	152
	Table D.19:USB3 Connector (JP7)	152
D.17	COM2 (CN12).....	153
	Table D.20:COM2 (CN12).....	153
D.18	COM3 RS-232 serial port (CN13)	153
	Table D.21:COM3 RS-232 serial port (CN13).....	153
D.19	COM4 RS-232 serial port (CN14)	154
	Table D.22:COM1 RS-232 serial port (CN14).....	154
D.20	Keyboard & PS/2 Mouse connector (CN22).....	154
	Table D.23:COM1 RS-232 serial port (CN14).....	154
D.21	Parallel port (CN9).....	155
	Table D.24:Parallel port (CN9)	155
D.22	Keyboard & PS/2 Mouse connector (CN22).....	155
	Table D.25:USB1/USB2 (CN19/CN20).....	155

Appendix E Pin Assignments 158

E.1	Introduction	158
E.2	Desktop Stand Mounting.....	158
	Figure E.1:Desktop stand mounting	159
E.3	Swingarm Stand Mounting.....	160
	Figure E.2:Swingarm stand mounting	160

General Information

This chapter gives background information on the POC-153 panel PC.

Sections include:

- Introduction
- How to Use This Manual
- Specifications
- Dimensions

Chapter 1 General Information

1.1 Introduction

The POC-153 panel PC is a Pentium® III processor-based computer that is designed to serve as a Point of Care (POC) and as a desktop computer. It is a PC-based system with 15" color TFT LCD display, on-board PCI Ethernet controller, multi-COM port interfaces and a 16-bit stereo audio controller. With a built-in CD-ROM drive, floppy drive and PCMCIA expansion sockets, the POC-153 is as compact and user-friendly as a notebook computer. Unlike notebook computers, the POC-153 is more durable and versatile in all applications. The panel PC can be placed on a desktop to replace the traditional desktop computer. In addition, its "fit anywhere" design makes it very flexible and able to be used in many different kinds of installations. It can be panel mounted or stood upright on a desktop.

For system integrators, this simple, complete, compact and highly integrated system lets you easily build a panel PC into your applications. Common industrial applications include factory automation systems, precision machinery, and production process control. It is also suitable for many nonindustrial applications, including interactive kiosk systems, entertainment management, and car park automation. Our panel PC is a reliable, cost-effective solution to your application's processing requirements.

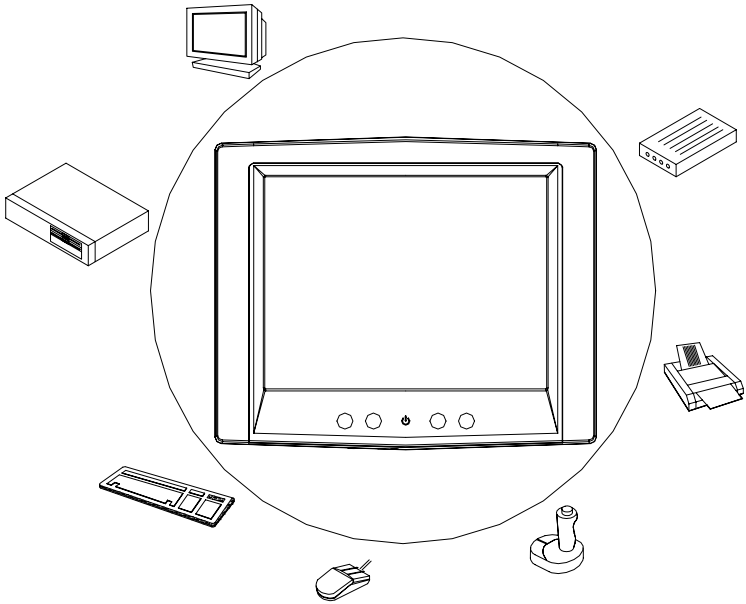

Figure 1.1: The POC-153 in perspective

1.2 How to use this manual

This manual contains all the information you need to set up and use the panel PC. In addition to this manual, you may also want to consult the manuals for your operating system, software applications and peripherals.

Whether you are a new or an experienced user, you will benefit more from this manual if you are familiar with its organization. This manual is divided into ten chapters, plus five appendices.

Chapter 1 (this chapter) outlines the organization of this User's Manual, provides a complete specification description of the POC-153, and summarizes its main features.

Chapter 2 provides step-by-step instructions to help you set up and begin using the panel PC as quickly as possible.

Chapter 3 provides important information about the daily use of the panel PC, including using the CD-ROM drive, floppy drive and enjoying the panel PC's audio capabilities.

Chapter 4 provides detailed step-by-step instructions to help you install the internal key components, including the CPU, hard disk drive, memory module, and so on.

Chapter 5 provides a detailed description of jumper settings and connectors of the motherboard of the POC-153.

Chapter 6 explains the VIA chipset.

Chapter 7 explains the PCI bus Ethernet setup.

Chapter 8 explains the VGA setup.

Chapter 9 explains the audio setup.

Chapter 10 explains the PCMCIA setup.

Chapter 11 explains how to configure and use the optional touchscreen.

Chapter 12 explains the Award BIOS setup.

Appendix A details the LCD specifications used in the POC-153.

Appendix B explains how to program the watchdog timer.

Appendix C includes various exploded diagrams of the POC-153. These diagrams will help system integrators disassemble the panel PC.

Appendix D includes all pin assignments on the connectors.

Appendix E helps users install the POC-153, which is mountable in a variety of ways.

If you are a commercial user and the panel PC unit you bought is a complete set with CPU, hard disk drive, SDRAM, CD-ROM drive, floppy disk drive and PCMCIA expansion slots included, you may only need to read Chapters 1 through 3 regarding hardware operation. For additional drivers and BIOS setup information, you should read Chapters 6 through 12. (Chapter 11 is for users who want information about the optional touchscreen.) If you want to upgrade your system, you may follow the instructions in Chapters 4 and 5. If you are a system integrator who wants to integrate the panel PC into your system, you can refer to appendices A through E for information such as pin assignments and how to fully disassemble the POC-153.

A suggested guide for reading this manual is shown below:

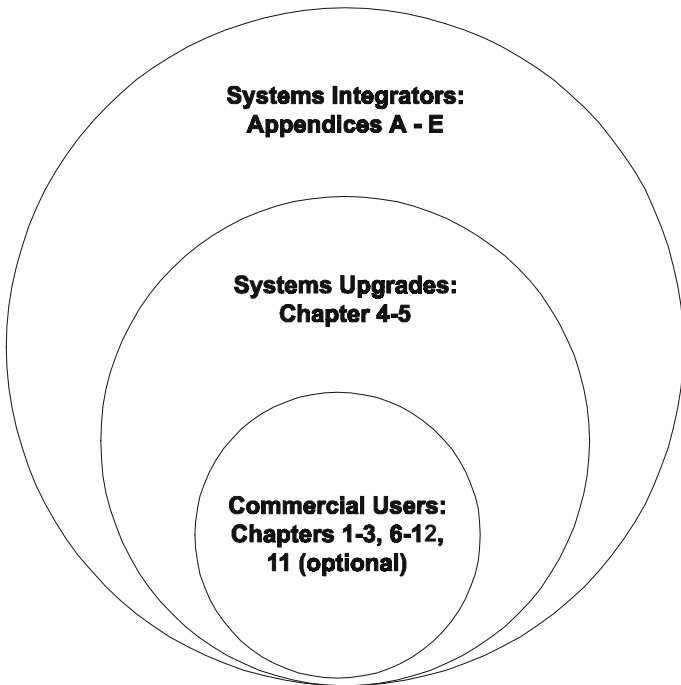

Figure 1.2: How to read the POC-153 manual

1.3 Specifications

General

- **Dimensions (W x H x D):** 414 x 339 x 115 mm (16.30" x 13.34" x 4.52")
- **Weight:** 6.5 kg (14.4 lb)
- **Power supply:**

AC model: 80 watts

Input voltage: 100~250 VAC , 3 A max. @ 50 ~ 60 Hz

Output voltage: +5 V @ 12 A, +12 V @ 1 A

DC model: 60 watts

Input voltage: 24 VDC , 5 A max or 12 VDC, 7 A max

Output voltage: +5 V @ 10 A, +12 V @ 1 A

- **Cooling fan dimensions (L x W x H):**
CPU fan: 60 x 60 x 10 mm (2.4" x 2.4" x 0.4")
- **Disk drive housing:** Space for one 2.5" HDD, one 12.7 mm compact CD-ROM drive, and one slim type 3.5" FDD
- **Front panel:**
IP65 protection (not for the model with SAW touchscreen)

Standard PC functions

- **CPU:** Intel Celeron or Pentium III (Tualatin) or VIA C3 processor up to 1.26GHz
- **BIOS:** Award 256 KB Flash BIOS, supports Plug & Play, APM
- **Chipset:** VIA PN133T (TwisterT) / VT82C686B
- **2nd level cache:** On-die 256 or 512 KB
- **RAM:** Two 168-pin DIMM socket accepts up to 1GB SDRAM
- **PCI bus master IDE interface:** Supports two connectors. Each connector has one channel and supports two IDE devices. Each channel supports PIO modes 0 ~ 4, DMA mode 0 ~ 2, and Ultra DMA 33/66/100 simultaneously. The secondary connector is designated for the CD-ROM drive. BIOS supports IDE CD-ROM boot-up
- **Floppy disk drive:** Supports up to two FDDs (720 KB / 1.44 MB). One built-in FDD included inside FDD housing

- **Parallel port:** One parallel port, supports SPP/EPP/ECP parallel mode. BIOS configurable to LPT1, LPT2, LPT3 or disabled
- **Serial ports:** Four serial ports with three RS-232 ports (COM1, 3, and 4), one RS-232/422/485 port (COM2). All ports are compatible with 16C550 UARTs
- **Universal serial bus (USB) port:** Supports up to two USB ports
- **PCI/ISA bus expansion slot:** Accepts either one ISA card or one PCI bus card
- **Watchdog timer:** 62-level, interval 1 ~ 62 seconds. Automatically generates system reset or IRQ11 when the system stops due to a program error or EMI. Jumperless selection and software enabled/disabled
- **Battery:** 3.0 V @ 195 mA lithium battery

Flat panel interface

- **Chipset:** VIA TwisterT chip with integrated Savage4 2D/3D video accelerator
- **Display memory:** Support for 8 MB to 32 MB Frame Buffer (SMA)
- **Display type:** Simultaneously supports CRT and flat panel displays (EL, LCD and gas plasma)
- **Display resolution:** Supports non-interlaced CRT and TFT LCD displays up to 1024 x 768 @ 256K

Audio function

- **Chipset:** VIA 82C686 South Bridge
- **Audio controller:** AC97 Ver. 2.0 compliant interface, Multi stream, Direct sound and Direct Sound 3D acceleration
- **Stereo sound:** 18-bit full-duplex codec
- **Audio interface:** Microphone-in, Line-in, Line-out and Game ports (MPU-401)

PCI bus Ethernet interface

- **Chipset:** Realtek RTL 8100BL PCI local bus Ethernet controller
Ethernet interface: Full compliance with IEEE 802.3u 100Base-T and 10 Base-T specifications. Includes software drivers and boot ROM
- **100/10Base-T auto-sensing capability**

PCMCIA interface

- **Chipset:** RICOH 5C478II

- **Cardbus controller:** A PC card controller offers a single chip solution as a bridge between the PCI bus and the Cardbus
- **PCI bus interface:** Complies with PCI Local Bus Specification 2.1, and supports the 32-bit Cardbus (Card-32) and the 16-bit PC card (Card-16) without external buffers
- **Hot insertion and removal**

Touchscreen (optional)

Type	Analog Resistive	Surface Acoustic Wave (SAW)
Resolution	Continuous	4096 x 4096
Light Transmission	75%	91%
Controller	RS-232 Interface (uses COM4)	RS-232 Interface (uses COM4)
Power Consumption	+5V@200mA	+5V@150mA
Software Driver	Supports DOS, Windows 3.1, Windows 95/98 Windows NT4.0	
Durability (touches in a lifetime)	30 million	50 million

Note: The POC-153 with the optionally installed touchscreen will share COM4. Once the touchscreen is installed, COM4 cannot be used for other purposes.

Optional modules

- **CPU:** Intel Celeron or Pentium III (Tualatin) or VIA C3 processor up to 1.26 GHz
- **Memory:** 32/64/128/256/512/1024 MB SDRAM
- **HDD:** 2.5" HDD
- **Touchscreen:** Analog resistive or Surface Acoustic Wave
- **CD-ROM drive:** Compact 24X CD-ROM or above
- **DVD-ROM drive:** Compact 6X DVD-ROM or above
- **PCMCIA interface:** Complies with 1995 PCMCIA card standard. Supports two PCMCIA card/CardBus slots. Two sockets support both a 16-bit PCMCIA card and a 32-bit CardBus simultaneously. Hot insertion and removal.

Note: The PCMCIA driver of Windows 95 which includes a PCMCIA interface is available on the "Drivers and Utilities" CD-ROM of your POC-153 package.

Environment

- **Temperature:** 0 ~ 45° C (32 ~ 122° F)
- **Relative humidity:** 10 ~ 95% @ 40° C (non-condensing)
- **Shock:** 10 G peak acceleration (11 msec duration)
- **Power MTBF:** 100,000 hrs
- **Certification:**
 - AC Model:** EMC2001: CE, FCC, VCCI, BSMI approved
Safety: UL1950, UL2601-1, EN60950 and EN60601-1 approved
 - DC Model:** FCC, UL2601-1, EN60601-1 approved

1.4 Dimensions

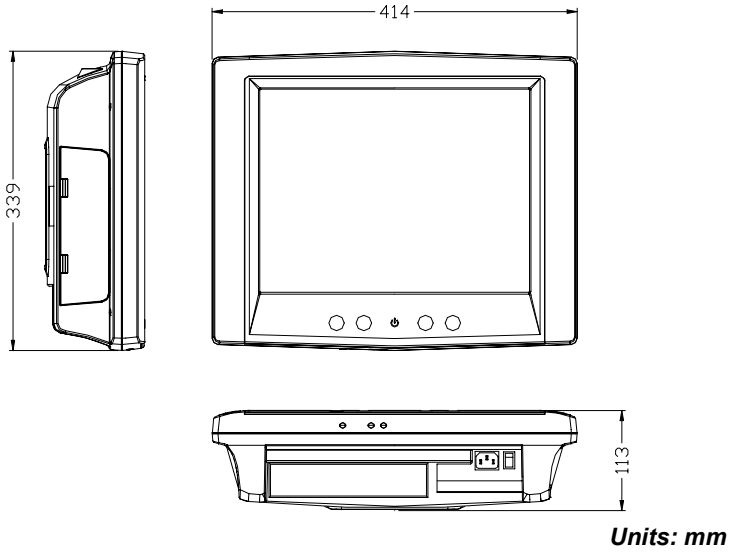

Figure 1.3: Dimensions of the POC-153

System Setup

This chapter details system setup on the POC-153 panel PC.

Sections include:

- A Quick Tour of the POC-153
- Preparing for First-time Use
- Installation Procedures
- Running the BIOS Setup Program
- Installing System Software
- Installing the Drivers

Chapter 2 System Setup

2.1 A Quick Tour of the Panel PC

Before you start to set up the panel PC, take a moment to become familiar with the locations and purposes of the controls, drives, connectors and ports, which are illustrated in the figures below.

When you place the POC-153 upright on the desktop, its front panel appears as shown in Figure 2-1.

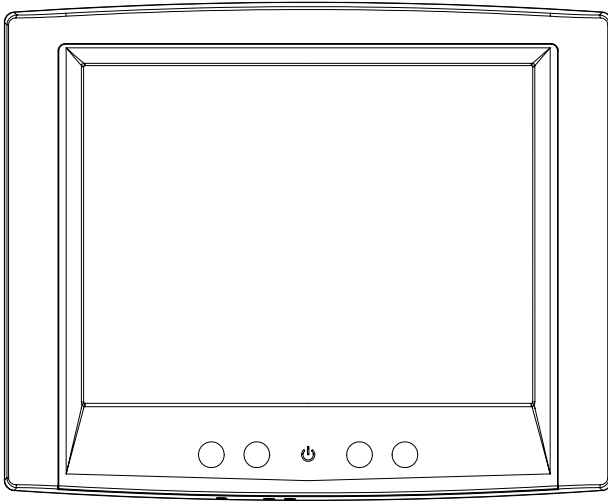

Figure 2.1: Front view of POC-153 panel PC

When you look at the left side of the panel PC, you will see the floppy disk drive, CD-ROM drive and PCMCIA expansion sockets, as shown in Fig. 2-2.

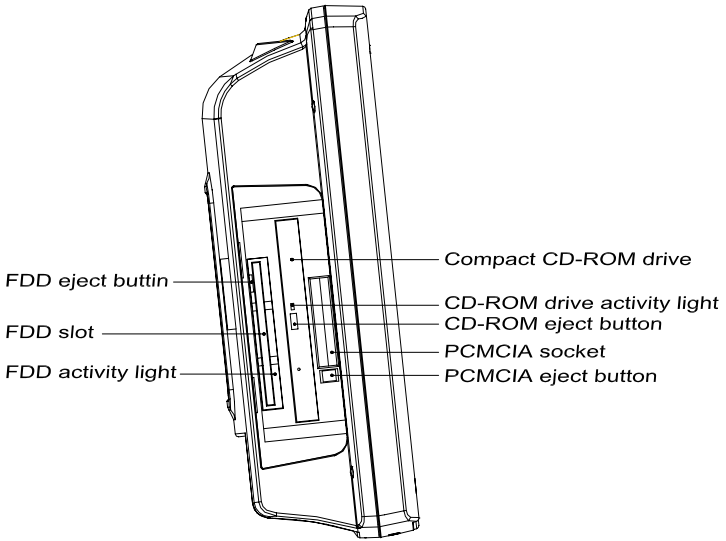

Figure 2.2: Left side view of POC-153

When you turn the POC-153 around and look at its rear cover, you will find the PCI/ISA expansion slot located on the left side. This slot is covered by a side panel cover. The sunken I/O section is at the bottom of the panel PC, as shown in Fig. 2-3. (The I/O section includes various I/O ports, including serial ports, parallel port, the Ethernet port, USB ports, the microphone jack, and so on.)

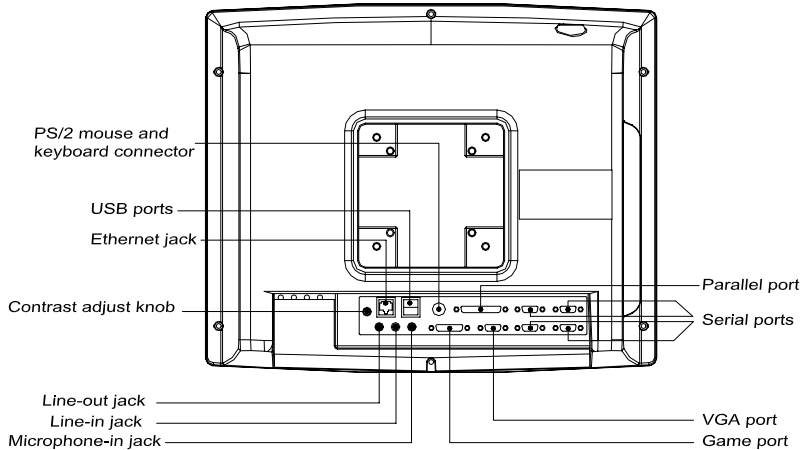

Figure 2.3: Rear view of POC-153

Figure 2-4 shows the I/O section and power switch of POC-153.

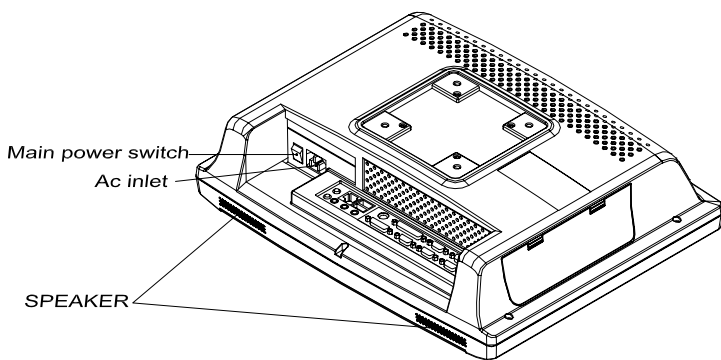

Figure 2.4: Rear and side view of POC-153

2.2 Preparing for First-time Use

Before you start to set up the POC-153, you should have at least the following items ready:

- Power cord (in the accessory box)
- Y-shaped connector (in the accessory box)
- Keyboard
- Mouse (for system software installation, i.e. Microsoft Windows NT, etc.)

2.3 Installation Procedures

2.3.1 Connecting the power cord

The POC-153 can only be powered by an AC electrical outlet (100 ~ 250 volts, 50 ~ 60 Hz). Be sure to always handle the power cords by holding the plug ends only.

Follow these procedures in order:

1. Connect the female end of the power cord to the AC inlet of POC-153. (See Fig. 2-5.)
2. Connect the 3-pin male plug of the power cord to an electrical outlet.

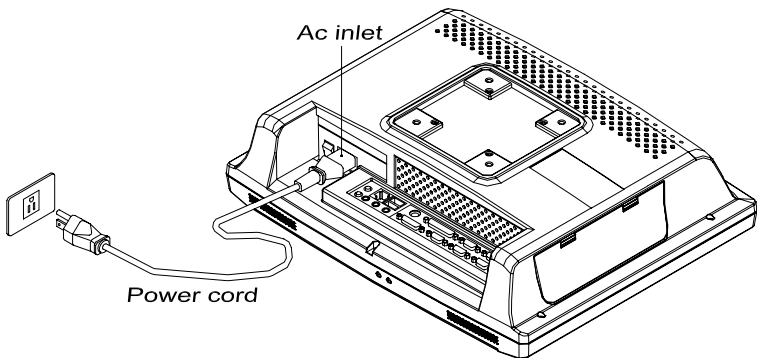
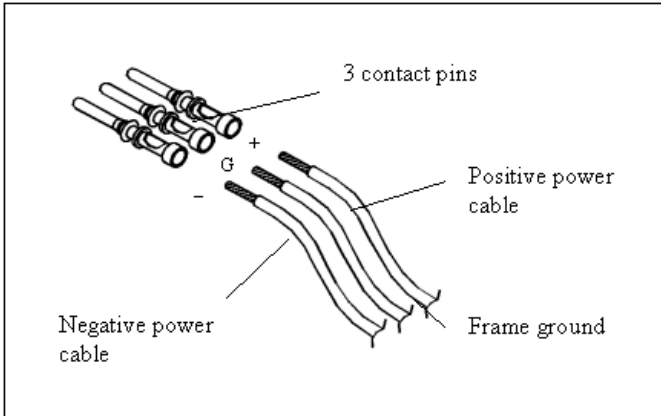

Figure 2.5: Connecting the power cord

2.3.2 Installing the DC power insulator with hood

The panel PC can also be powered by DC electrical outlet (24 VDC or 12 VDC, which depends on the power type). Follow the procedure in order to install the DC power insulator with hood then make sure to connect the insulator with the system.



1. Connect the three contact pins individually to the negative and positive power cables of the power adaptor, as well as to the frame ground cable. Solder firmly.

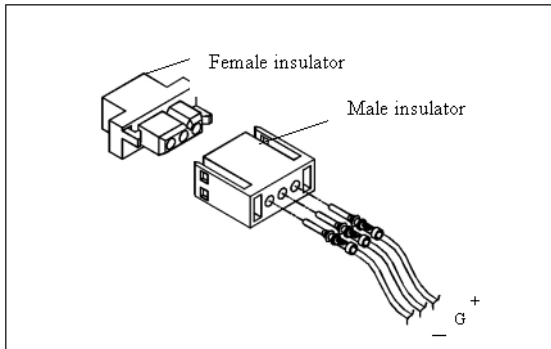

2. Align the soldered pins and their cables with the corresponding polarization marks on the front part of the male insulator (+ / G / -). Now plug the pins separately into the holes of the male insulator.

Pin 1 should go into the positive DC power input (+), pin 2 connects to the frame ground (G), and pin 3 should be plugged into the negative DC power input (-).

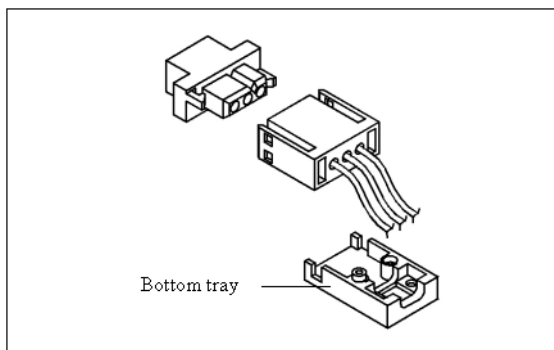

3. Mount the front part of the male insulator onto the bottom tray.

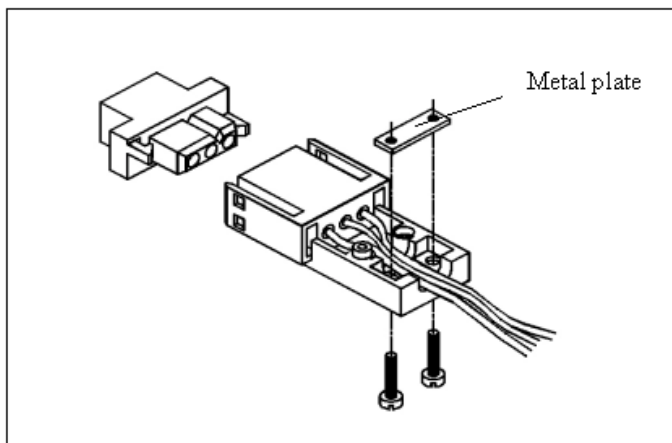

4. Use the metal plate and the two screws to secure the cables to the bottom tray. Please refer to the illustration above.

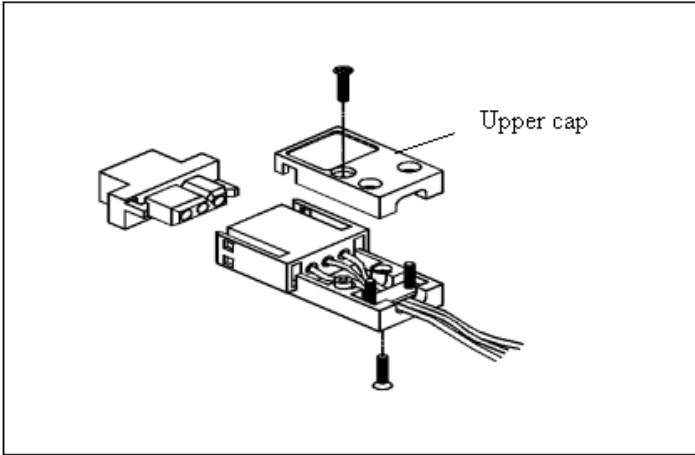

5. Attach the upper cap to the bottom tray and secure it with the screws.

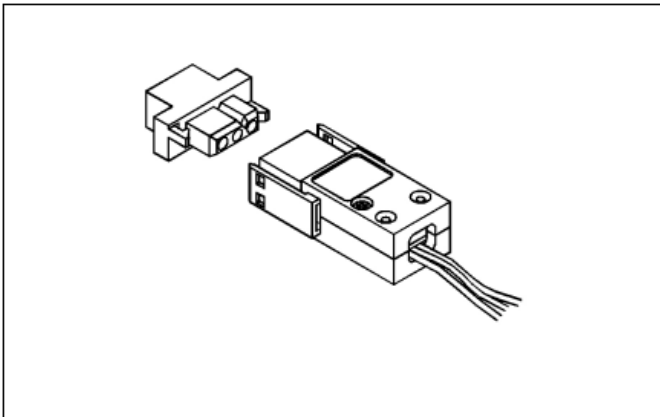

6. Now that you have completed the assembly of the male insulator, plug it into the female insulator.

2.3.3 Connecting the keyboard and mouse

1. Connect the Y-shaped adapter to the PS/2 mouse and keyboard port on the I/O section of the panel PC. (See Fig. 2-6.)
2. Connect the PS/2 mouse and keyboard to the Y-shaped adapter. (See Fig. 2-6.)

If you use a serial mouse and your POC-153 has a touchscreen, you can connect the mouse to any COM port except COM4.

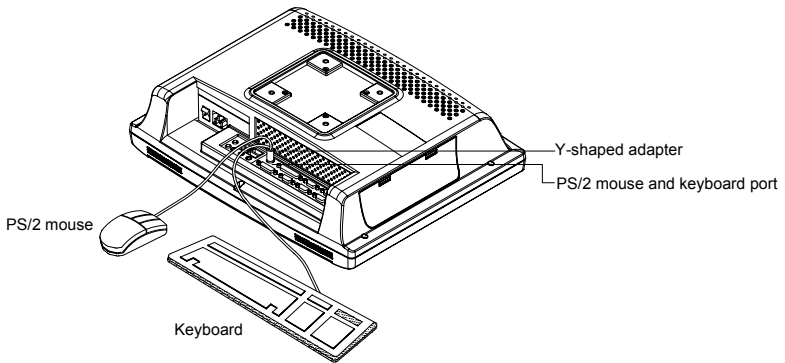

Figure 2.6: Connecting the keyboard and mouse

2.3.4 Switching on the power

Switch on the power switch on the rear cover. (See Fig. 2-4.)

2.4 Running the BIOS Setup Program

Your POC-153 is likely to have been properly set up and configured by your dealer prior to delivery. You may still find it necessary to use the panel PC's BIOS (Basic Input-Output System) setup program to change system configuration information, such as the current date and time or your type of hard drive. The setup program is stored in read-only memory (ROM). It can be accessed either when you turn on or reset the panel PC, by pressing the "Del" key on your keyboard immediately after powering on the computer.

The settings you specify with the setup program are recorded in a special area of memory called CMOS RAM. This memory is backed up by a battery so that it will not be erased when you turn off or reset the system. Whenever you turn on the power, the system reads the settings stored in CMOS RAM and compares them to the equipment check conducted during the power on self-test (POST). If an error occurs, an error message will be displayed on screen, and you will be prompted to run the setup program.

If you want to change the setup of BIOS, refer to Chapter 12 for more detailed information.

2.5 Installing System Software

Recent releases of operating systems from major vendors include setup programs which load automatically and guide you through hard disk preparation and operating system installation. The guidelines below will help you determine the steps necessary to install your operating system on the panel PC hard drive.

Note: Some distributors and system integrators may have already pre-installed system software prior to shipment of your POC-153.

If required, insert your operating system's installation or setup diskette into the diskette drive until the release button pops out. (See Fig. 3-1.)

The BIOS of the panel PC supports system boot-up directly from the CD-ROM drive. You may also insert your system installation CD-ROM into the CD-ROM drive. (See Fig. 3-2.) Refer to Chapter 12 if you wish to change the BIOS settings.

Power on your panel PC or reset the system by pressing the "Ctrl"+"Alt"+"Del" keys simultaneously. The panel PC will automatically load the operating system from the diskette or CD-ROM.

If you are presented with the opening screen of a setup or installation program, follow the instructions on screen. The setup program will guide you through preparation of your hard drive, and installation of the operating system.

If you are presented with an operating system command prompt, such as A:\>, then you must partition and format your hard drive, and manually copy the operating system files to it. Refer to your operating system user's manual for instructions on partitioning and formatting a hard drive.

2.6 Installing the Drivers

After installing your system software, you will be able to set up the Ethernet, SVGA, audio, PCMCIA and touchscreen functions. All the drivers except the CD-ROM drive driver are stored in a CD-ROM disc entitled "Drivers and Utilities." The CD-ROM drive driver is stored in a floppy disk. Both the CD-ROM and the floppy disk can be found in your accessory box.

To set up the CD-ROM function, insert the floppy disk with the CD-ROM drive driver into the floppy disk drive and type "install" after the following prompt is displayed on screen:

A: > INSTALL

Press "Enter", and the installation process will be completed in a few seconds.

The standard procedures for installing the "VIA 4 in 1," Ethernet, VGA, audio, PCMCIA and touchscreen drivers are described in Chapters 6, 7, 8, 9, 10 and 11 respectively.

For your reference, the directory of drivers on the "Drivers and Utilities" CD-ROM is:

D:\	Audio	(driver)
	Cardbus	(PCMCIA driver)
	Elotouch	(TouchScreen driver)
	LAN	(driver)
	Microtouch	(TouchScreen driver)
	VGA	(driver)
	Via4in1	(driver)

The various drivers and utilities in the CD-ROM disc have their own text files which help users install the drivers and understand their functions. These files are a very useful supplement to the information in this manual.

Note: The drivers and utilities used for the POC-153 panel PCs are subject to change without notice. If in doubt, check Advantech's website or contact our application engineers for the latest information regarding drivers and utilities.

Using the Panel PC

This chapter details installing the POC-153 panel PC hardware.

Sections include:

- Introduction
- Floppy Drive
- CD-ROM Drive
- PCMCIA
- PS/2 Mouse and Keyboard
- PCI/ISA Bus Expansion
- Parallel Port
- Serial COM Ports
- VGA Port
- Game Port
- USB Ports
- Audio Interface
- Ethernet
- Adjusting the LCD Contrast and Brightness
- Touchscreen (optional)

Chapter 3 Using the Panel PC

3.1 Introduction

This chapter describes basic features and procedures for using the panel PC. Topics covered include the floppy drive, CD-ROM drive, I/O ports, touchscreen, and so on..

3.2 Floppy drive

To insert a floppy disk, hold it with your left hand, between your thumb and your other fingers, and push it toward the drive. (See Fig. 3-1.)

1. Slide the disk until it clicks into place.

Note: New disks must be formatted by your operating system before you can use them for data storage. See your operating system manual for details.

To eject a floppy disk, first make sure that the drive activity light is off, and then press the eject button on the drive. When the disk pops out of the drive, remove it and store it properly.

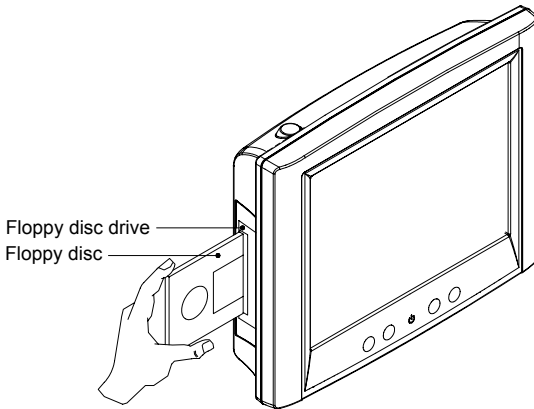

Figure 3.1: Inserting and ejecting a floppy disk

3.3 CD-ROM Drive

To insert a CD-ROM disc, press the eject button of the CD-ROM drive. The yellow activity light will flash and the front panel will come out a short distance. Using your fingertips, hold the top and bottom of the front panel and pull it outward to the very end. (See Fig 3-2.) Align the center hole of the CD-ROM disc with the center circle of the CD-ROM holding plate. Press the transparent ring around the center hole of the CD-ROM until you hear a click. Push the front panel of the CD-ROM drive back to its original place.

To eject a CD-ROM disc, first ensure that the drive activity light is off. Then press the eject button on the drive. When the disc pops out of the drive, remove it and store it properly.

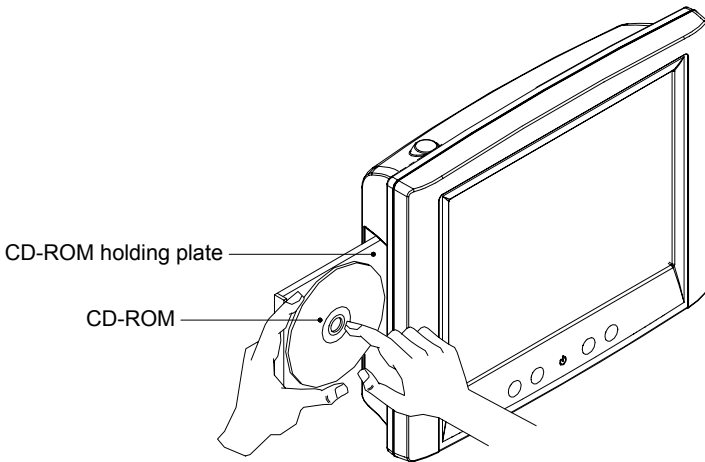

Figure 3.2: Inserting and ejecting a CD-ROM

3.4 PCMCIA

PCMCIA cards are inserted and ejected in much the same way as diskettes.

To insert a PCMCIA card, align the card with the socket and slide the card into the socket until it locks into place. Note that some PCMCIA memory cards must be prepared by your operating system before you can use them for data storage. See your PCMCIA card manual for details.

To eject a PCMCIA card, first ensure that the panel PC is not accessing the memory card or device. Then press the appropriate eject button on the socket. When the card pops out of the socket, remove it and store it properly.

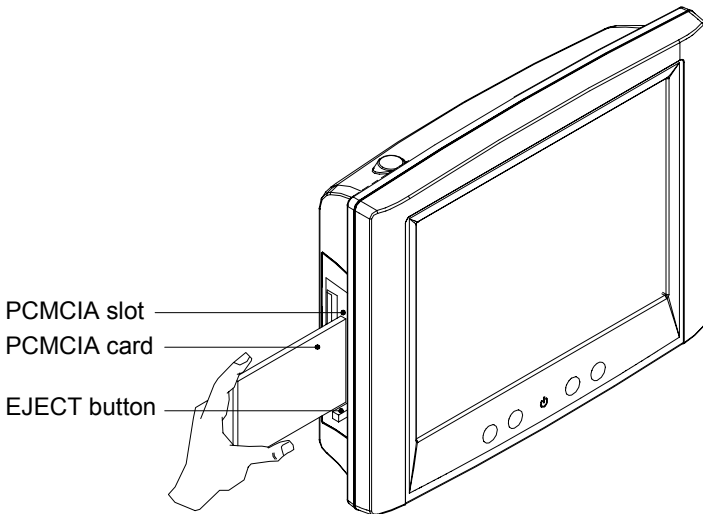

Figure 3.3: Inserting and ejecting a PCMCIA card

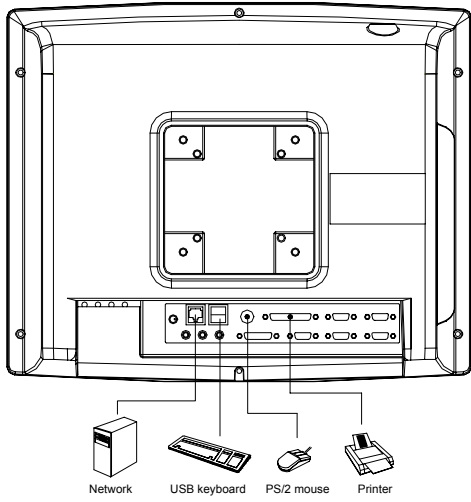

Figure 3.4: I/O interface (excluding COM ports)

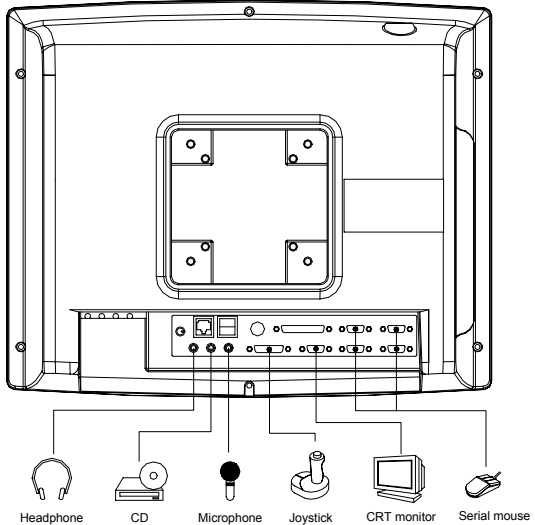

Figure 3.5: I/O interface (excluding COM ports)

3.5 PS/2 Mouse and Keyboard

If you wish to use a full-size desktop keyboard and PS/2 mouse with your panel PC, follow these instructions:

1. Be sure the panel PC is turned off.
2. Connect the Y-shaped adapter to the PS/2 mouse and keyboard port on the rear bottom side of the rear cover. (See Fig. 3-4 and Fig. 2-6.)
3. Attach the keyboard to the 5-pin port of the Y-shaped adapter.
4. Attach the PS/2 mouse to the 6-pin female PS/2 port of the Y-shaped adapter.
5. Turn on the panel PC.

3.6 PCI/ISA Bus Expansion

The panel PC supports PCI and ISA bus expansion cards. To integrate a new PCI or ISA bus card into your system, follow these instructions:

1. Turn off the panel PC.
2. Unscrew the two screws on the top of the PCI/ISA bus expansion slot cover, and remove this cover.
3. Remove the metal plate by unscrewing the single attaching screw.
4. Insert the PCI or ISA bus card into the PCI/ISA slot of the riser card. (See Fig. 3-6 overleaf.)
5. Run the setup program within your operating system to configure your system.

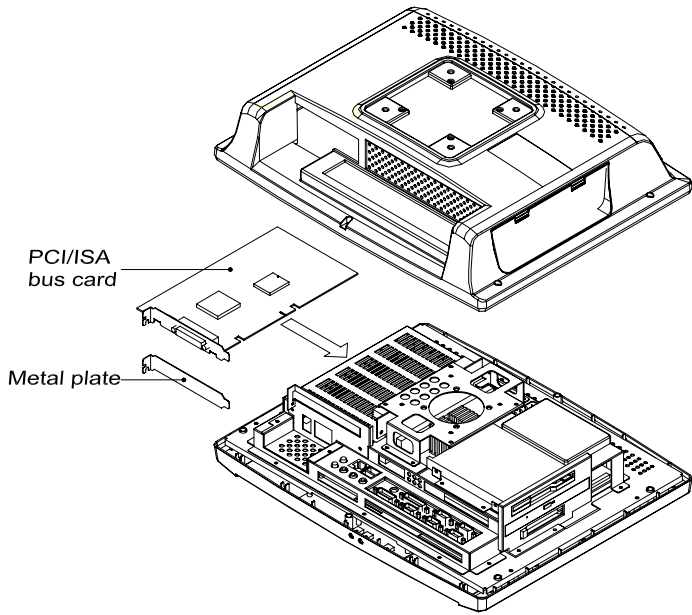

Figure 3.6: PCI/ISA bus expansion

3.7 Parallel port

The POC-153 supports the latest EPP and ECP parallel port protocols for improved performance and versatility with compatible printers or other devices.

To connect the POC-153 to a printer or other devices:

1. Be sure both the POC-153 and the printer/devices are turned off.
2. Connect the 25-pin male connector of the printer cable to the 25-pin female port on the panel PC labelled "parallel port".
3. If necessary, attach the other end of your printer cable to your printer, and fasten any retaining screws. A typical parallel printer connection is illustrated in Fig. 3-4.
4. Turn on the printer and any other peripheral devices you may have connected to the POC-153, and then turn on the POC-153.
5. If necessary, run the POC-153's BIOS setup program to configure the parallel port to respond as required by your printer and software operating environment.

3.8 Serial COM ports

There are four serial COM ports on the bottom of the rear cover. You can easily attach a serial device to the POC-153, such as an external modem or mouse. Follow these instructions:

1. Be sure the POC-153 and any other peripheral devices you may have connected to the POC-153 are turned off.
2. Attach the interface cable of the serial device to the POC-153's serial port. (See Fig. 3-5.) If necessary, attach the other end of the interface cable to your serial device. Fasten any retaining screws.
3. Turn on any other peripheral devices you may have connected to the POC-153, and then turn on the POC-153.
4. Refer to the manual(s) which accompanied your serial device(s) for instructions on configuring your operating environment to recognize the device(s).
5. Run the BIOS setup program and configure the jumper settings to change the mode of the COM ports. (See Section 5.4)

3.9 VGA Port

An external VGA-compatible device may be connected to the system through the 15-pin external port located on the rear of the system unit. The POC-153 simultaneously supports an external CRT monitor in addition to its own LCD display.

1. Be sure the POC-153 is turned off.
2. Connect the external monitor to the system. (See Fig. 3-5.)
3. Turn on the POC-153 and the external monitor.

3.10 Game Port

An external game device may be connected to the system through the 15-pin external port located on the rear of the system unit.

1. Be sure the POC-153 is turned off.
2. Connect the external joystick or game device to the system. (See Fig. 3-5.)
3. Turn on the POC-153 and the external joystick or game device (if applicable).
4. Install the driver before you use the joystick or game device.

3.11 USB Ports

An external USB device may be connected to the system through the 4-pin USB ports located on the rear side of the system unit.

1. Connect the external device to the system. (See Fig. 3-4.)
2. The USB ports support hot plug-in connection. You should install the device driver before you use the device.

3.12 Audio Interface

The audio interface includes three jacks: microphone in, line out and line in. (See Fig. 3-5.) Their functions are:

Microphone in: Use an external microphone to record voice and sound.

Line out: Output audio to external devices such as speakers or earphones.

Line in: Input audio from an external CD player or radio.

1. Connect the audio device to the system. (See Fig. 3-5.)
2. Install the driver before you use the device.

3.13 Ethernet

External devices on your network may be connected to the system through the external ethernet port located on the rear side of the system unit.

1. Be sure the POC-153 is turned off.
2. Connect the external device(s) to the POC-153. (See Fig. 3-4.)
3. Turn on the POC-153 and the external device(s).
4. Under DOS, run the RSET8139 program to check the hardware network status before installing the Ethernet driver.
5. Run the Ethernet driver to connect up to the network.

3.14 Adjusting the LCD Contrast and Brightness

The contrast control knob does not function because the POC-153 includes the TFT LCD display. Only POC-153s with DSTN LCD displays have this function.

The brightness control knob allows you to adjust the brightness of the LCD display panel.

3.15 Touchscreen (Optional)

The touchscreen is connected to COM4. Its function is similar to that of a mouse. The only difference is that you put your fingertip on the screen to move the cursor.

You will need to install the touchscreen driver before it will work. The touchscreen drivers for various operating systems are stored on the CD-ROM disc inside the accessory box. The touchscreen manual can also be found on this disc. Read Chapter 11 of this manual carefully before you install the driver.

Hardware Installation and Upgrade

This chapter tells how to set up the POC-153 hardware, including instructions on setting jumpers and connecting peripherals, switches and indicators. Be sure to read all the safety precautions before you begin the installation procedures.

Sections include:

- Jumpers and Connectors
- Disassembling the Panel PC
- Installing the 2.5" Hard Disk Drive (HDD)
- Installing the Central Processing Unit (CPU)
- Installing the SDRAM Memory Module
- Installing the Floppy Disk Drive (FDD) and Slim CD-ROM Drive

Chapter 4 Hardware Installation and Upgrade

4.1 Jumpers and Connectors

The POC-153 consists of a PC-based computer that is housed in a plastic rear panel and a metal shielding case. Your HDD, SDRAM, power supply, CPU, and so on are all readily accessible by removing the rear panel and shielding case. Any maintenance or hardware upgrades can be easily completed after removing the rear panel and shielding case.

If you are a systems integrator and need to know how to completely disassemble the panel PC, you can find more useful information in Appendix C.

Warning!



Do not remove the plastic rear cover until you have verified that no power is flowing within the panel PC. Power must be switched off and the power cord must be unplugged. Every time you service the panel PC, you should be aware of this.

4.2 Disassembling the Panel PC

The following are standard procedures for disassembling the panel PC before you upgrade your system. All procedures are illustrated in Fig. 4-1.

1. Unscrew the seven screws that secure the plastic rear cover, and then remove the cover.
2. Unscrew the two screws of the PCI/ISA expansion PCB, and remove it.
3. Unscrew the four screws that secure the CPU cover.
4. Remove the floppy drive, HDD, and CD-ROM cables; then remove the side panel.
5. Unscrew the ten screws of the shielding case, and remove it.

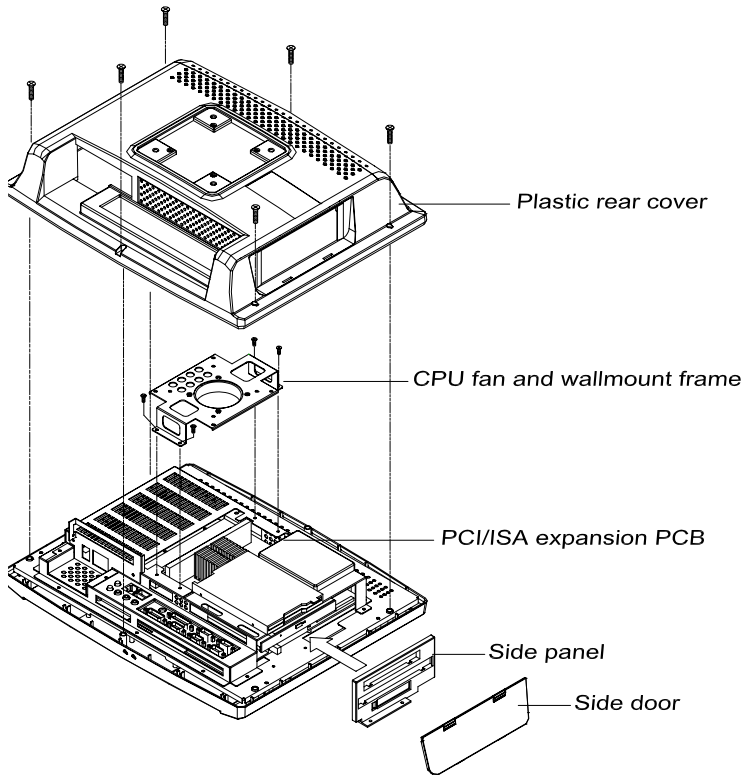

Figure 4.1: Disassembling rear cover of POC-153

4.3 Installing the 2.5" Hard Disk Drive (HDD)

You can attach one enhanced Integrated Device Electronics (IDE) hard disk drive to the panel PC's internal controller which uses a PCI local-bus interface. The advanced IDE controller supports faster data transfer and allows the IDE hard drive to exceed 528 MB. The following are instructions for installation:

1. Detach and remove the plastic rear cover and side panel.
2. There is a metal plate which holds the HDD to the upper right-hand side of the metal shielding case. (See Fig. 4-2.) Remove the two screws on the metal plate.
3. Pull the metal plate toward the outside of the unit, and remove it from the two lugs of the shielding case.
4. Place the HDD on the metal plate, and tighten the four screws from the bottom of the metal plate.
5. The HDD cable (1 x 44-pin to 1 x 44-pin) is next to the metal plate. Connect the HDD cable to the HDD. The another end of the HDD cable is connected to the PC board (CN16). Make sure that the red/blue wire corresponds to Pin 1 on the connector, which is labeled on the board. Plug the other end of the cable into the IDE hard drive, with Pin 1 on the cable corresponding to Pin 1 on the hard drive.

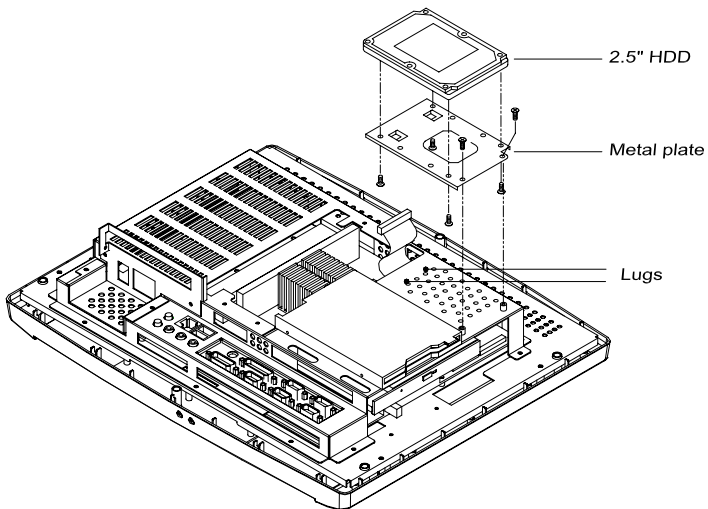

Figure 4.2: Installing the primary 2.5" HDD

4.4 Installing the Central Processing Unit (CPU)

The POC-153's central processing unit (CPU) can be upgraded to improve system performance. The panel PC provides one 370-pin ZIF (Zero Insertion Force) socket (Socket 370). The CPU must come with an attached heat sink and CPU fan to prevent overheating.

Warning! *The CPU may be damaged if operated without a heat sink and a fan*



Caution! *Always disconnect the power cord from your panel PC when you are working on it. Do not make connections while the power is on as sensitive electronic components can be damaged by the sudden rush of power. Only experienced electronics personnel should open the panel PC.*



1. Detach and remove the plastic rear cover.
2. Remove the four screws of the CPU cover, and remove the cover.
3. Detach the CPU fan power cable from the CPU fan.
4. There is a metal plate which holds the FDD and slim CD-ROM drive to the metal shielding case. There are two screws ("A") on this metal plate. Loosen these two screws.
5. Remove the plastic side cover of the FDD.
6. Push the FDD and slim CD-ROM drive toward the outside of the panel PC, as far as they will go. This will expose the entire CPU assembly underneath.
7. Locate the ZIF socket and open it by first pulling the lever sideways away from the socket, then upwards at an angle of 90 degrees.
8. Insert the CPU with the correct orientation. The notched corner of the CPU (with the white dot) should point towards the end of the lever. The end of the lever is the blank area where one hole is miss-

ing from the corner of the square array of pin holes. An arrowhead printed on the motherboard points to the end of the lever. (See Fig. 4-3 overleaf.)

9. Slide the CPU in gently. It should insert easily. If not, pull the lever up a little more and make sure the pins of the CPU correspond with the holes of the socket. **DO NOT USE EXCESSIVE FORCE!**
10. Press the lever down. The plate will slide across slightly.
11. Place the heat sink on top of the CPU and fasten it with the heat sink clip (shown in Fig. 4-3).
12. Move the FDD and slim CD-ROM drive back to their original position.
13. Put back the plastic side cover of the FDD.
14. Tighten the two screws ("A") on the metal plate.
15. Connect the CPU fan power cable to the 3-pin connector (FAN1).
16. Put back the CPU cover, and secure the four screws on it.

Note: To remove the CPU, follow steps 1 through 7 above. You should then be able to freely lift out the CPU chip.

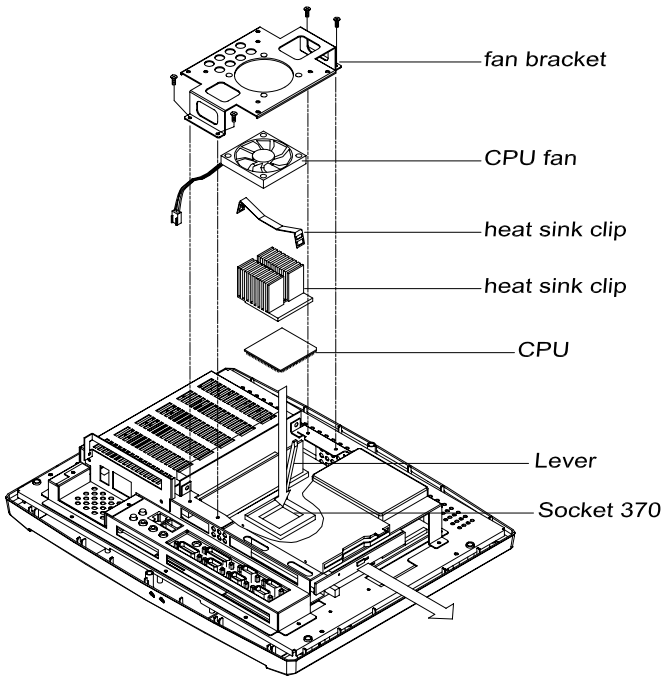

Figure 4.3: Installing the CPU

4.5 Installing the SDRAM Memory Module

You can install from 32 to 1024 MB of SDRAM memory. The panel PC system provides two 168-pin DIMM (Dual Inline Memory Module) socket and supports 3.3 V SDRAM with a minimum speed of 12 ns.

Note: *The module can fit into the socket only one way. Pin 1 of the DIMM module must line up with the small arrowhead printed on the motherboard next to the DIMM socket. The golden pins of the module must point down into the DIMM socket.*

1. Detach and remove the plastic rear cover and CPU cover.
2. Push the two white eject levers on each side of the DIMM outward until they are separated from the black vertical posts. (See Fig. 4-4.)
3. Insert the memory module into the socket at an angle of 90 degrees.
4. Push the two eject levers toward the vertical posts at each end of the socket until the module is upright.

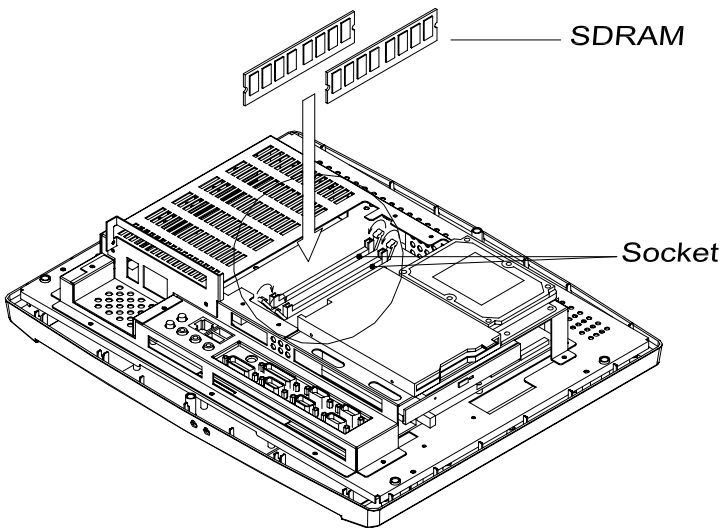

Figure 4.4: Installing SDRAM

4.6 Installing FDD and Slim CD-ROM Drive

Installation of a floppy disk drive and slim CD-ROM drive is similar to that for a hard disk drive. The metal plate for holding the FDD and the CD-ROM support bracket are on the left side of the shielding case. The 26-pin and 40-pin yellow FPC cables are for connecting the FDD and CD-ROM respectively. Only 3.5" floppy disk drives (720 KB and 1.44 MB) and slim CD-ROM drives can be attached to the metal plate and CD-ROM support bracket.

1. Detach and remove the plastic rear cover and side panel.
2. There is a metal plate which holds the FDD and slim CD-ROM drive to the metal shielding case. There is also a slim CD-ROM support bracket which is attached to the shielding case. There are two screws ("A") on the metal plate. Unscrew these two screws. (See Fig. 4-5.)
3. Push the metal plate toward the outside of the unit. This will free it from the two lugs of the shielding case.
4. Slide the CD-ROM support bracket toward the outside of the panel PC, and remove it.
5. Place the FDD on the metal plate. There are four small screws, two on each side of the metal plate. Tighten these screws.
6. Place the support bracket against the slim CD-ROM drive. It should fit neatly into the space allocated for the bracket. (See Fig. 4-5.)
7. Attach the support bracket to the slim CD-ROM drive by tightening the two small screws located in the bracket.
8. Insert the FDD assembly into the shielding case. Then insert the slim CD-ROM drive assembly into the shielding case. Make sure that the hooked lug on the slim CD-ROM drive assembly engages into the corresponding slot of the combined FDD assembly and shielding case.
9. Connect the FDD cable (26-pin to 26-pin) and CD-ROM cable (40-pin to 40-pin). The other end of the FDD cable is connected to connector CN10 on the PC board. The other end of the CD-ROM cable is connected to connector CN18 on the PC board.
10. Slide the FDD assembly and slim CD-ROM assembly toward the inside of the panel PC, as far as they will go.
11. Secure the two screws ("A") of the metal plate to the shielding case.

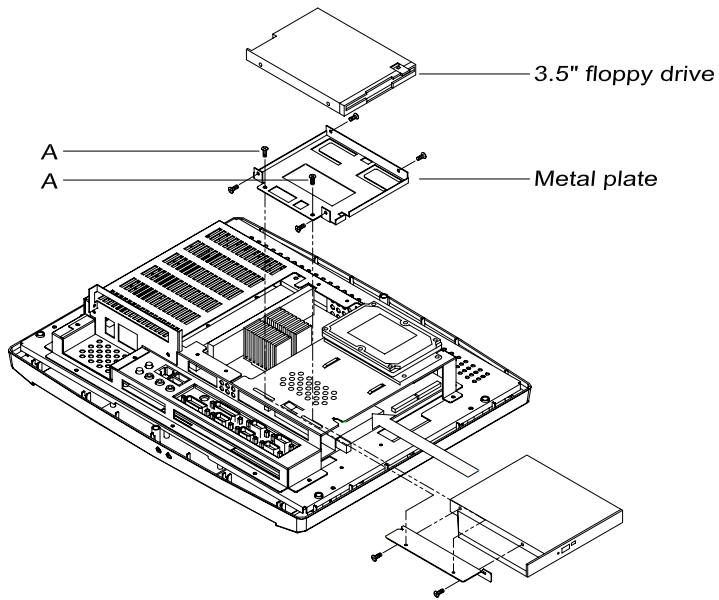

Figure 4.5: Installing FDD and slim CD-ROM drive

Jumper Settings and Connectors

This chapter tells how to set up the POC-153 hardware, including instructions on setting jumpers and connecting peripherals, switches and indicators. Be sure to read all the safety precautions before you begin the installation procedures.

Sections include:

- Jumpers and Connectors
- CPU Installation
- CMOS Clear for External RTC (JP8)
- COM-port Interface
- Internal -12 V Source Selection Setting (JP1)
- VGA Interface
- Watchdog Timer Configuration

Chapter 5 Jumper Settings & Connectors

5.1 Jumpers and Connectors

5.1.1 Setting jumpers

You can configure your POC-153 to match the needs of your application by setting jumpers. A jumper is the simplest kind of electrical switch. It consists of two metal pins and a small metal clip (often protected by a plastic cover) that slides over the pins to connect them. To “close” a jumper, you connect the pins with the clip. To “open” a jumper you remove the clip. Sometimes a jumper will have three pins, labeled 1, 2, and 3. In this case, you would connect either pins 1 and 2 or pins 2 and 3.

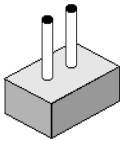

open

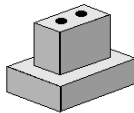

closed

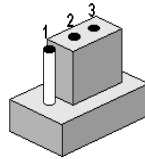

closed 2-3

The jumper settings are schematically depicted in this manual as follows:.

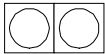

open



closed



closed 2-3

A pair of needle-nose pliers may be helpful when working with jumpers. If you have any doubts about the best hardware configuration for your application, contact your local distributor or sales representative before you make any changes.

5.1.2 Jumpers and switch

The motherboard of the POC-153 has a number of jumpers that allow you to configure your system to suit your applications. The table below lists the function of each of the board's jumpers.

Table 5.1: Jumpers and their functions

Label	Function
JP1	Internal -12 V source selection setting
JP2	LAN power type selection
JP3	Watchdog timer action
JP4	CMOS clear
JP6	COM2 RS-232/422/485 setting
J12	COM/COM2 pin 9 output type setting
J13	COM3 pin 9 output type setting
J14	COM4 pin 9 output type setting
SW1	Panel type setting

5.1.3 Connectors

Onboard connectors link the panel PC to external devices such as hard disk drives or floppy drives. The table below lists the function of each of the board's connectors.

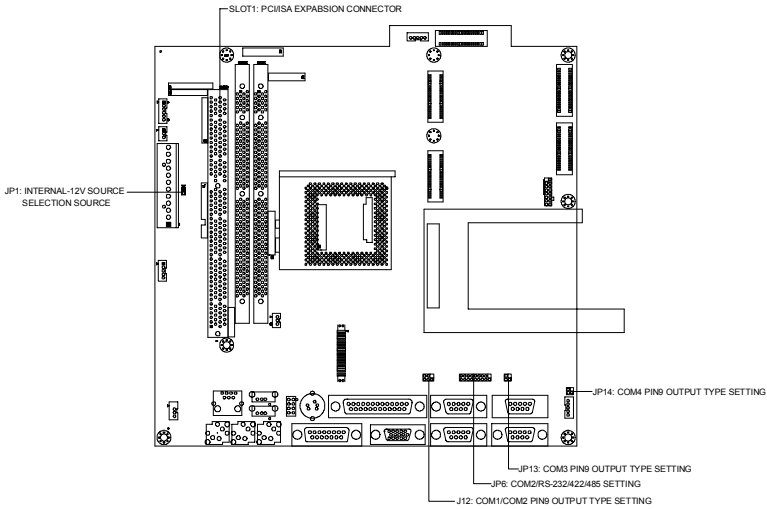

Figure 5.1: Jumpers on the POC-153 motherboard

Table 5.2: POC-153 connectors

Label	Function
J1	AT power connector
J4	Inverter power connector
J6	Internal speaker connector (Reserved)
J8	Front panel control connector (Reserved)
J9	IR connector (Reserved)
CN2	Flat panel display connector
CN3	Flat panel display connector
CN10	FDD connector
CN11	COM1 connector
CN12	COM2 connector
CN13	COM3 connector
CN14	COM4 connector
CN16	EIDE hard disk drive connector
CN18	CD-ROM connector
CN23	LVDS channel 1/channel 2 connector
JP7	USB3 connector
CN27	Touchscreen interface & PS/2 connector
FAN1	CPU fan power connector
FAN2	System fan power connector
SLOT1	PCI/ISA bus expansion slot

5.1.4 Locating connectors

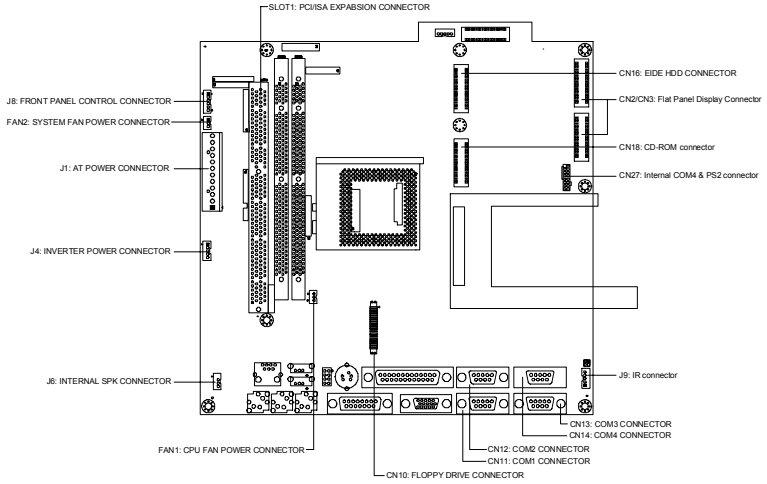

Figure 5.2: Connectors on POC-153 motherboard

5.2 CPU Installation

You can install an Intel® Pentium® III or Celeron™ CPU without setting any frequency ratio or voltage.

Warning! To avoid damaging the computer, always turn off the power supply before setting “Clear CMOS”. Set the jumper back to “Normal operation” before turning on the power supply.





5.3 CMOS Clear for External RTC (JP4)

This jumper is used to erase CMOS data and reset system BIOS information.

The procedure for clearing CMOS is:

1. Turn off system.
2. Short pin 2 and pin 3.
3. Return jumper to pins 1 and 2.
4. Turn on the system. The BIOS is now reset to its default setting.

Table 5.3: CMOS clear (JP4)

*Normal operation	Clear CMOS
	

* default setting

5.4 COM-port interface (JP6)

The POC-153 provides four serial ports (COM1, 3, 4: RS-232; COM2: RS-232/422/485) in one COM port connector.

5.4.1 COM2 RS-232/422/485 setting (JP6)

COM2 can be configured to operate in RS-232, RS-422, or RS-485 mode. This is done via JP6.

Table 5.4: COM2 RS-232/422/485 setting (JP6)

*RS-232

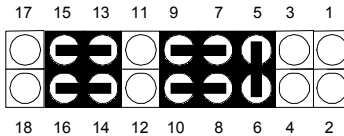

RS-422

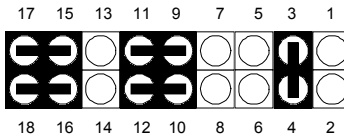

RS-485

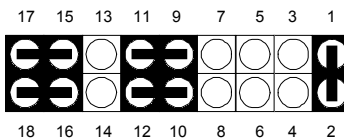

* default setting

The IRQ and the address ranges for COM1, 2, 3, and 4 are fixed. However, if you wish to disable the port or change these parameters later you can do this in the system BIOS setup. The table overleaf shows the default settings for the panel PC's serial ports.

COM1 and COM2 are one set. You can exchange the address range and interrupt IRQ of COM1 for the address range and interrupt IRQ of COM2. After exchanging, COM1's address range is 3F8 ~ 3FF and its

request IRQ is IRQ4: and COM2's address range is 2F8 ~ 2FF and its interrupt IRQ is IRQ3.

COM3 and COM4 are another set. Their selectable function is the same as the COM1/COM2 set.

Table 5.5: Serial port default settings

Port	Address Range	Interrupt
COM1	3F8 ~ 3FF	IRQ4
COM2	2F8 ~ 2FF	IRQ3
COM3	3E8 ~ 3EF	IRQ10
COM4	2E8 ~ 2EF	IRQ5

5.4.2 COM1/2/3/4 pin 9 output setting (J12, J13, J14)

Table 5.6: COM1/2/3/4 pin 9 settings (J12,13,14)

COM1/COM2 (J12)

*Normal operation

+5 V output

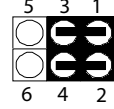
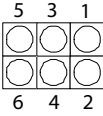

COM3 (J13)

*Normal operation

+5 V output

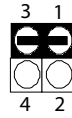
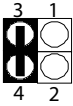

COM4 (J14)

*Normal operation

+5 V output

+12 V output

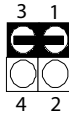
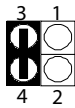

*default setting

5.5 VGA interface

The POC-153's AGP VGA interface can drive conventional CRT displays. It is also capable of driving a wide range of flat panel displays, including electroluminescent (EL), gas plasma, passive LCD and active LCD displays.

5.5.1 LCD panel power setting

The POC-153's AGP SVGA interface supports 5 V and 3.3 V LCD displays. The LCD cable already has a built-in default setting. You do not need to adjust any jumper or switch to select the panel power.

5.6 Watchdog Timer Configuration (JP3)

An onboard watchdog timer reduces the chance of disruptions which EMP (electromagnetic pulse) interference can cause. This is an invaluable protective device for standalone or unmanned applications. Setup involves one jumper and running the control software. (Refer to Appendix B.)

When the watchdog timer activates (i.e. CPU processing has come to a halt), it can reset the system or generate an interrupt on IRQ11. This can be set via jumper J4 as shown below:

Table 5.7: Watchdog activity selection (JP3)

*System reset			IRQ11		
1	2	3	1	2	3

* default setting

5.7 Wake on LAN select (JP2)

The POC-153 provides Wake-on LAN function when ATX power is used. To enable Wake-on LAN function, the JP2 should be set as shown below:

Table 5.8: Wake-on-LAN select (JP2)

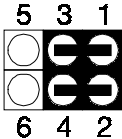
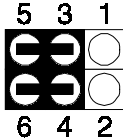

*Normal Power	Wake-on-LAN
	

* default setting

5.8 Internal -12 V Source Selection Setting (JP1)

The panel PC provides an internal -12 V source in an expansion slot, available for various expansion card applications.

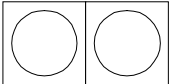
Table 5.9: Internal -12 V source selection setting (JP1)

* Onboard -12 V support	External -12 V input
	

* default setting

VIA Chipset

This chapter provides information on VIA chipset configuration.

Sections include:

- Introduction
- Installation of VIA 4-in-1 driver
 - for Windows 98/NT/2000/ME
- Further Information

Chapter 6 VIA Chipset

6.1 Introduction

The POC-153 uses the chipset PN133T (codename: Twister) from VIA Technologies, Inc., built-in high performance 2D/3D Savage4 graphics, flexible 66/100/133MHz system bus settings, support for PC100/133 SDRAM and multiple power saving modes make the VIA PN133 the ideal integrated SMA chipset for the Intel Pentium® III, Intel® Celeron, and VIA C3 processor.

The VIA VT82C686B PSIPC (PCI Super-I/O Integrated Peripheral Controller) can support Intel and non-Intel based processor to PCI bus bridge functionality to make a complete Microsoft PC99-compliant PCI/ISA system, moreover, it also supports master mode enhanced IDE controller with dual channel DMA engine (includes UltraDMA-33/66/100) and interlaced dual channel commands.

6.2 Driver Installation

Before installing the Ethernet driver, note the procedures below. You must know which operating system you are using in your POC-153, and then refer to the corresponding installation flow chart. Then just follow the steps described in the flow chart. You will quickly and successfully complete the installation, even if you are not familiar with instructions for Windows..

Important: 1. *The following windows illustrations are examples only. You must follow the flow chart instructions and pay attention to the instructions which then appear on your screen.*

Notes: 1. *The CD-ROM drive is designated as "D" throughout this chapter.*
2. *<Enter> means pressing the "Enter" key on the keyboard.*

6.2.1 Installation for Windows 98/NT/2000/ME

1.
 - a. Select "Start", "Run".
 - b. Enter the driver path "D:\VIA4in1\Setup.exe".
 - c. Click "OK".

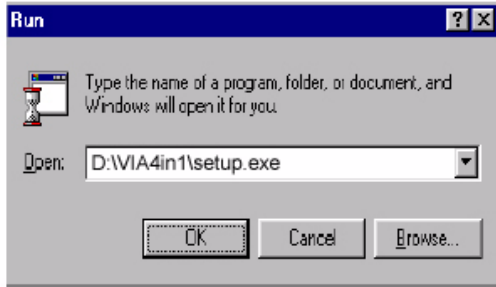

2.
 - a. Press "Next" to continue the installation.



3. a. Press "Yes" to accept the agreement."

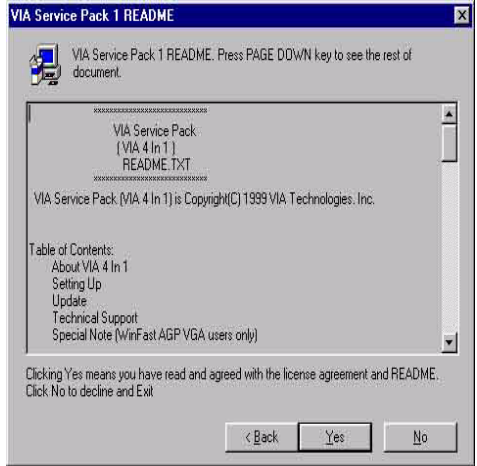

4. Choose all, then click "Next"

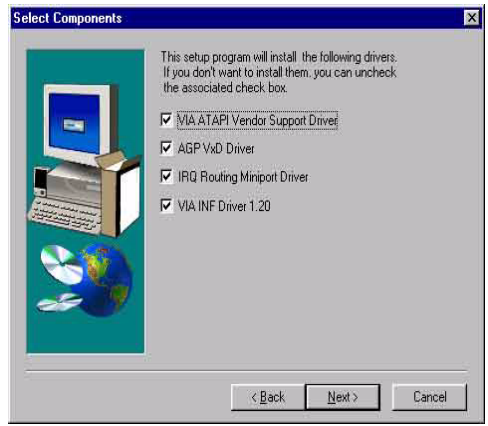

5. Click “Next”

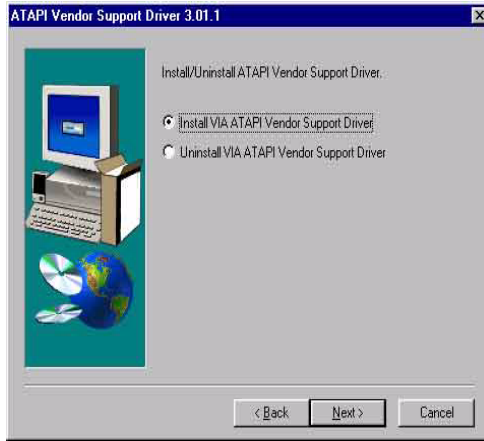

6. a. Choose if you want to enable the DMA mode or ignore, then press "Next"

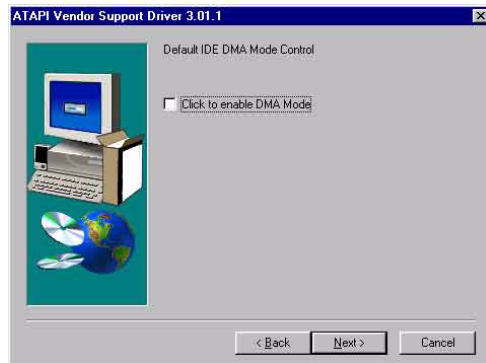

7. Click “Next”.

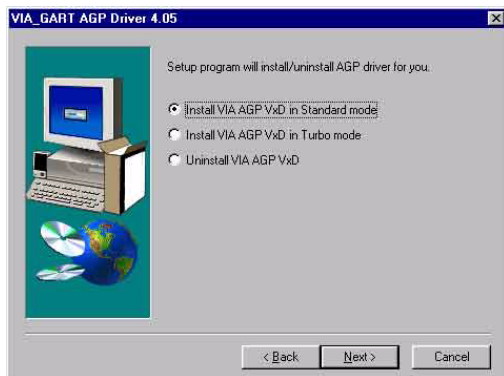

8. Click “Next”.

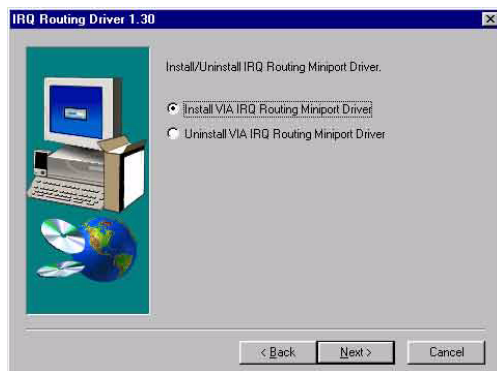

9. Click "Finish" to reboot the system.



6.3 Further Information

For further information about the AGP/VGA installation in your POC-153, including driver updates, troubleshooting guides and FAQ lists, visit the following web resources:

VIA website: www.via.com.tw
Advantech websites: www.advantech.com
www.advantech.com.tw

PCI Bus Ethernet Interface

This chapter provides information on Ethernet configuration.

Sections include:

- Introduction
- Installation of Ethernet Driver
 - for Windows 98/2000/ME
 - for Windows NT
 - for Windows XP
- Further Information

Chapter 7 PCI Bus Ethernet Interface

7.1 Introduction

The POC-153 is equipped with a high performance 32-bit Ethernet chipset, which is fully compliant with IEEE 802.3 100 Mbps CSMA/CD standards. It is supported by major network operating systems. It is also both 100Base-T and 10Base-T compatible.

The Ethernet port provides a standard RJ-45 jack. The network boot feature can be utilized by incorporating the boot ROM image files for the appropriate network operating system. The boot ROM BIOS files are combined with system BIOS, which can be enabled/disabled in the BIOS setup.

7.2 Installation of Ethernet Driver

Before installing the Ethernet driver, note the procedures below. You must know which operating system you are using in your POC-153, and then refer to the corresponding installation flow chart. Then just follow the steps described in the flow chart. You will quickly and successfully complete the installation, even if you are not familiar with instructions for Windows.

Important: The following windows illustrations are examples only. You must follow the flow chart instructions and pay attention to the instructions which then appear on your screen.

Note 1: The CD-ROM drive is designated as "D" throughout this chapter.

Note 2: <Enter> means pressing the "Enter" key on the keyboard.

7.2.1 Installation for Windows 98/NT/ME/2000

1.
 - a. Select "Start", "Run"
 - b. Enter the path, "D:\Lan\Setup.exe"
 - c. Click "OK"

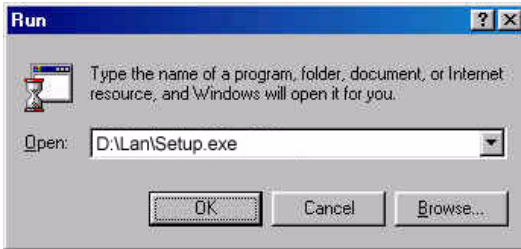

2.
 - a. Click "Next".



3. a. Select "Search for the best driver for your device. (Recommended)"
b. Click "Next"



4. a. Click "Next"

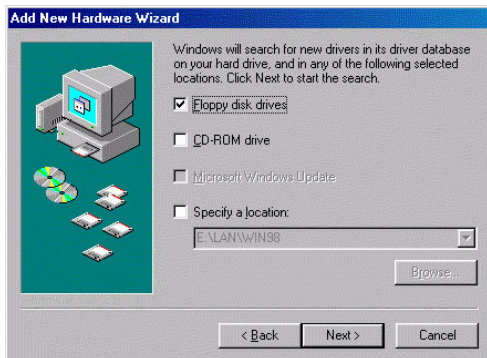

5. a. Click "Next"



6. a. Click "Next"



7. a. Type the path "D:\Lan\Win98"
b. Click "OK"

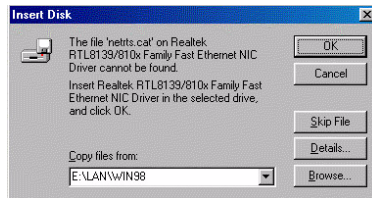

- Note:
1. Installation for Windows 95, please Type the path "D:\Lan\Win95"
 2. Installation for Windows 95osr2, please Type the path "D:\Lan\Win95osr2"
 3. Installation for Windows ME, please Type the path "D:\Lan\Winme"
 4. Installation for Windows NT/2000, please Type the path "D:\Lan\Win2000"
 5. Installation for Windows XP, please Type the path "D:\Lan\Winxp"

8. a. Click "Finish"

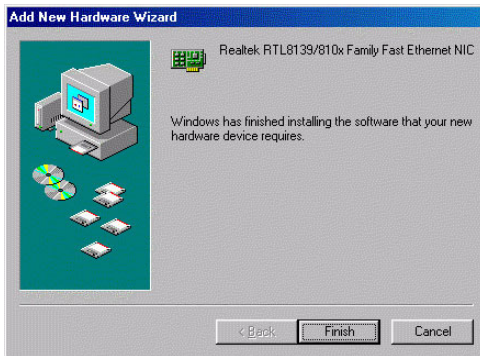

7.3 Further Information

Realtek website: www.realtek.com.tw

Advantech websites: www.advantech.com

www.advantech.com.tw

VGA Setup

This chapter provides information on the VGA setup.

Sections include:

- Introduction
- Installation of VGA Drivers
 - for Windows 98/2000/ME
 - for Windows NT
 - for Windows XP
- Further Information

Chapter 8 VGA Setup

8.1 Introduction

The POC-153 has an onboard AGP flat panel/VGA interface. The specifications and features are described as follows:

8.1.1 Chipset

The POC-153 uses a VIA Twister 8606T chipset from VIA Technology Inc. for its controller. It supports many popular LCD, and LVDS LCD displays and conventional analog CRT monitors. The VIA8606T VGA BIOS supports color TFT and DSTN LCD flat panel displays. In addition, it also supports interlaced and non-interlaced analog monitors (color and monochrome VGA) in high-resolution modes while maintaining complete IBM VGA compatibility. Digital monitors (i.e. MDA, CGA, and EGA) are NOT supported. Multiple frequency (multisync) monitors are handled as if they were analog monitors.

8.1.2 Display memory

The Twister chip can support 8/16/32MB frame buffer shared with system memory; the VGA controller can drive CRT displays or color panel displays with resolutions up to 1024 x 768 @ 256K colors.

8.1.3 Display types

CRT and panel displays can be used simultaneously. The POC-153 can be set in one of three configurations: on a CRT, on a flat panel display, or on both simultaneously. The system is initially set to simultaneous display mode. If you want to enable the CRT display only or the flat panel display only, please contact VIA Technology Inc., or our sales representative for detailed information.

8.2 Installation of the VGA Driver

Complete the following steps to install the VGA driver. Follow the procedures in the flow chart that apply to the operating system that you are using within your POC-153.

8.2.1 Installation for Windows 95/98/ME

1. a. Select "Start", "Run"
 - b. Enter the path "D:\VGA\Win9X_Me\Setup.exe"



- Notes:*
1. *Installation for Windows 2000, please Type the path "D:\VGA\Win2000\Setup.exe"*
 2. *Installation for Windows XP, please Type the path "D:\VGA\WinXP\Setup.exe"*

2. a. Click "Next"

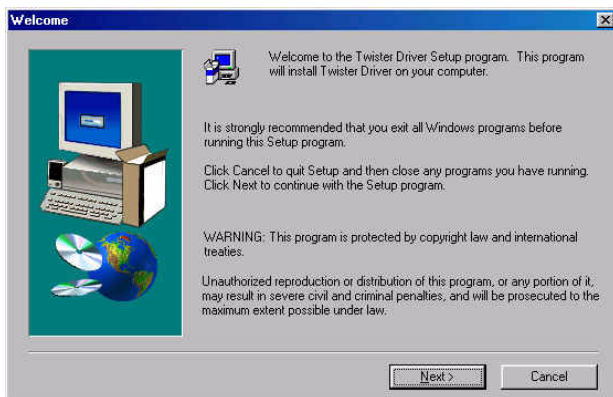

3. Click "Next"

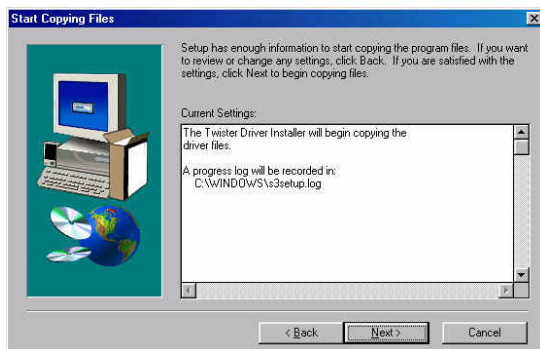

4. Click "Finish" to reboot

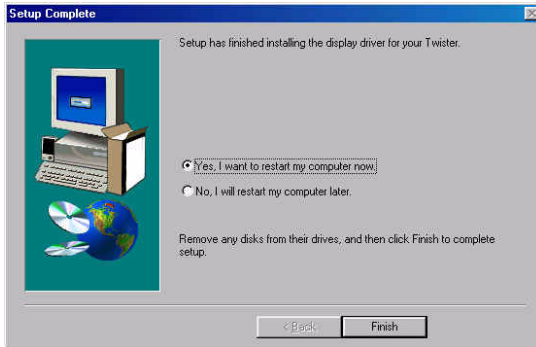

8.2.2 Installation for Windows NT

1. From "Start", select the "Settings group", then click on the "Control Panel" icon.
2. In the "Control Panel", double click on the "Display" icon.
3. In the "Settings" screen, click on the "Display Type..." button.
4. From the "Display Type" screen, and in the "Adapter Type" section, click on the "Change..." button.
5. In the "Change Display" screen, click on the "Have Disk..." button.
6. Insert the new display driver diskette into the A:\ drive, then click on the "OK" button.
7. From the list of displayed S3 devices, select your S3 device.
8. From "Third-party Drivers", click on the "Yes" button to proceed.
9. If a message appears stating the driver is already installed on the system, and asks if you want to use the current or new drivers, be sure to select the "New" button.
10. If prompted for the driver diskette a second time, click on the "Continue" button.
11. When the message "The drivers were successfully installed" is displayed, remove the display driver diskette, then click on the "OK" button.
12. Back at the "Display Type" window, click on the "Close" button.

13. Back at the "Display Properties" window, click on the "Close" button.
14. When you see the "System Settings Change" window, asking if you wish to restart your computer, click on the "Yes" window to reboot now.

8.3 Further Information

For further information about the AGP/VGA installation in your POC-153, including driver updates, troubleshooting guides and FAQ lists, visit the following web resources:

VIA website: www.via.com.tw

Advantech websites: www.advantech.com

www.advantech.com.tw

After installing the VGA driver under Win 98, if you want to play a VCD, please install Directx 8.1 (or higher) which you can find at www.microsoft.com.

Audio Setup

This chapter provides information on the Audio setup.

Sections include:

- Introduction
- Installation of Audio Driver
 - for Windows 98/2000/ME
 - for Windows NT
 - for Windows XP

Chapter 9 Audio Setup

9.1 Introduction

The POC-153's on-board audio interface provides high-quality stereo sound and FM music synthesis (ESFM) by using the VIA VT82C686 audio controller from VIA. The audio interface can record, compress, and play back voice, sound, and music with built-in mixer control.

The POC-153 on board audio interface also supports the Plug and Play (PnP) standard and provides PnP configuration for the audio, FM, and MPU-104 logical devices. It is compatible with Sound Blaster™; Sound Blaster Pro™ version 3.01, voice and music functions. The ESFM synthesizer is register compatible with the OPL3 and has extended capabilities.

9.2 Installation of the Audio Driver

Before installing the audio driver, please take note of the procedures detailed below. You must know which operating system you are using in your POC-153, and then refer to the corresponding installation flow chart. Just follow the steps in the flow chart. You can quickly and successfully complete the installation, even though you are not familiar with instructions for Windows.

- Notes:**
- 1. The windows illustrations in this chapter are intended as examples only. Please follow the listed steps, and pay attention to the instructions which appear on your screen.*
 - 2. For convenience, the CD-ROM drive is designated as "D" throughout this chapter.*
 - 3. <Enter> means pressing the "Enter" key on the keyboard.*

9.2.1 Installation for Windows 98/ME/2000/XP

1. a. Select "Start", "Run"
b. Enter the path "D:\Audio\Win98_ME_2000_XP\Setup.exe"



- Notes:*
1. *Installation for Windows 95, please Type the path "D:\Audio\Win95\Setup.exe"*
 2. *Installation for Windows NT, please Type the path "D:\Audio\WinNT\Setup.exe"*

2. Click "Finish"



PCMCIA

Sections include:

- Introduction
- Installation of PCMCIA driver for Windows 95

Chapter 10 PCMCIA

10.1 Introduction

The POC-153 is equipped with a high performance PCMCIA interface which complies with the 1995 PCMCIA card standard by using the RICOH Cardbus controller. The panel PC supports two PCMCIA card/ cardbus slots. Two sockets support both a 16-bit PCMCIA card and a 32-bit Cardbus simultaneously, with hot insertion and removal.

10.2 Installation of PCMCIA Driver

The PCMCIA driver for Windows 95 is included in the "Drivers and Utilities" CD-ROM included with your POC-153. The installation procedure is shown in the next section in this chapter.

Other operating systems such as Windows 98 and Windows NT also support PCMCIA drivers. However, the drivers for these operating systems are not included in the "Drivers and Utilities" CD-ROM. Installation for these operating systems is not explained in this manual..

Important: 1. *The following windows illustrations are examples only. You must follow the flow chart instructions and pay attention to the instructions which then appear on your screen.*

Notes: 1. *The CD-ROM drive is designated as "D" throughout this chapter.*
2. *<Enter> means pressing the "Enter" key on the keyboard.*

10.2.1 Installation for Windows 95

1. a. In "Start", "Run", type the path:
"D:\Cardbus\win95osr2\Setup.exe"

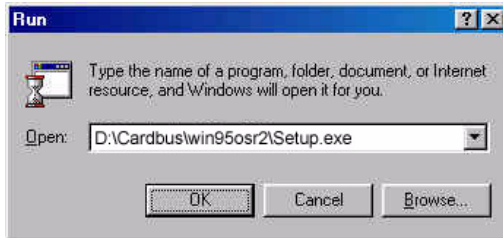

2. a. Click "Next" to continue the installation.

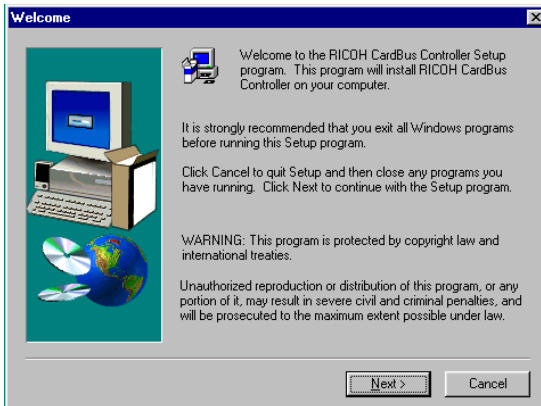

3. a. Click "Yes".

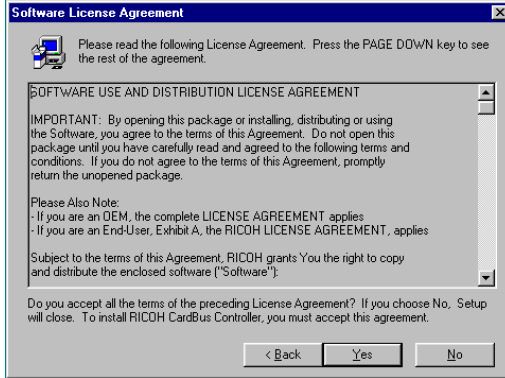

4. Click "Finish" to reboot the system.

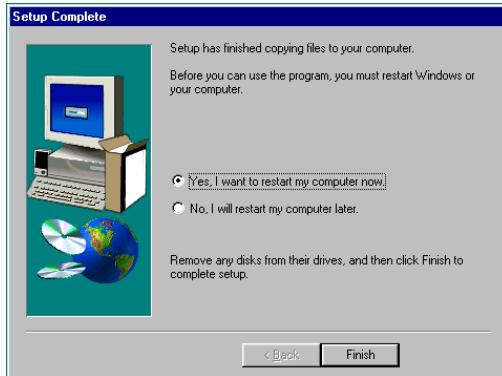

Touchscreen

Sections include:

- Introduction
- Installation of Driver for Resistive or SAW Touchscreen
 - for Windows 95
 - for Windows 98
 - for Windows NT
 - for Windows 2000
 - for Windows ME

Chapter 11 Touchscreen

11.1 Introduction

11.1.1 General information

The POC-153's optional touchscreen incorporates advanced second-generation 5-wire resistive or surface acoustic wave (SAW) technology. They allow 75% and 91% light transmission respectively. The resistive model has an anti-glare surface, but the SAW model does not. All models provide greatly enhanced visual resolution. They also have new improved scratch-resistant features.

The touchscreen is manufactured from UL-recognized components. When properly installed, the touchscreen's ball impact resistance meets the UL 1950 standard. Its fire resistance meets the UL-746C, 19 mm (0.75") flame test standard. Systems incorporating the touchscreen, controllers, and cables have been approved to FCC Class A and Class B standards.

For more detailed information, please visit the following websites:

Resistive and SAW models: www.elotouch.com

11.1.2 General specifications

Please refer to Chapter 1, Section 1.3 of this manual.

11.1.3 Environmental specifications

Temperature: $-10^{\circ} \sim 50^{\circ} \text{C}$ (operating)

$-40^{\circ} \sim 71^{\circ} \text{C}$ (storage)

Relative humidity:

90 RH at 35°C (operating)

90 RH at 35°C for 240 hours, non-condensing (storage)

Chemical resistance: The active area of the touchscreen is resistant to the following chemicals when exposed for a period of one hour at a temperature of 21°C (71°F):

- Acetone
- Methylene chloride
- Methyl ethyl ketone
- Isopropyl alcohol
- Hexane
- Ammonia-based glass cleaners
- Turpentine
- Mineral spirits
- Foods and beverages

11.2 Driver for Resistive or SAW Touchscreen

The touchscreen driver for Windows 95/98 contains a native, 32-bit driver and a 32-bit control panel program for the POC-153 system.

To facilitate installation of the touchscreen driver, you should read the instructions in this section carefully before you attempt installation.

Important: 1. *The following windows illustrations are examples only. You must follow the flow chart instructions and pay attention to the instructions which then appear on your screen.*

Notes:

1. *The CD-ROM drive is designated as "D" throughout this chapter.*
2. *<Enter> means pressing the "Enter" key on the keyboard.*

11.2.1 Installation for Windows 95/98/Me

1.
 - a. Insert the "Drivers and Utilities" CD.
 - b. Click the "Start" button, and then "Run".
 - c. Type the path "D:\Elotouch\Win9X_Me\Setup.exe".

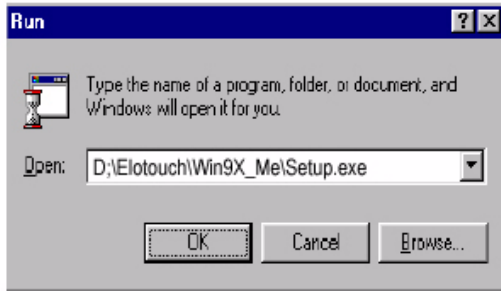

- Notes:*
1. *Installation for Windows NT, please type the path "D:\Elotouch\WinNT\SetupElo.exe"*
 2. *Installation for Windows 2000, please type the path "D:\Elotouch\Win2K\SetupElo.exe"*
 3. *Installation for Windows XP, please type the path "D:\Elotouch\WinXP\SetupElo.exe"*

2. a. Click "Yes".



3. a. Select the "Smart serial Controller on COM4" item.
b. Press the "OK" button.

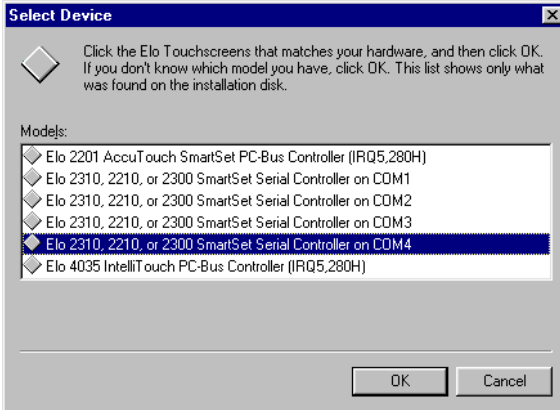

4. a. Click the "Yes" button to restart your computer.

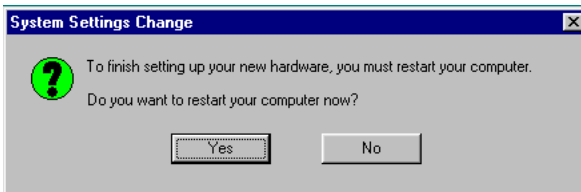

5. a. Touch targets to calibrate the touchscreen controller.

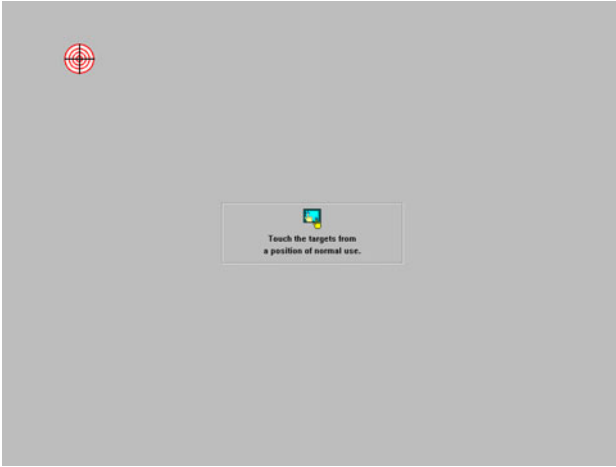

Note:

If you install Elotouch driver under Windows 2000, and find that the USB device might not work properly due to the incompatibility of Elotouch driver. The following is the solution from Elo:

Windows 2000: ConectMultiplePorts registry key

If the ConnectMultiplePorts registry key is set to 1, USB devices may not work on the system. Also, the following errors can be displayed by the System event Log:

- Service Control Management, ID=7009, Timeout (30000 ms) waiting for Elo TouchScreen Service Activation
- Mouclass, ID=9, Impossible to activate interrupts on \Device\PointerClass0

This can be corrected by running regedit and changing the following registry key from 1 to 0:

```
HKEY_Local_Machine
  System
    CurrentControlSet
      Services
        Mouclass
```

Parameters

ConnectMultiplePorts

Double-click the ConnectMultiplePorts text to edit the value, then close the registry editor and reboot the system.

For more information, please visit:

<http://www.elotouch.com/support/webtech/efw2kmultipleports.asp>

CHAPTER 12

Award BIOS Setup

This chapter describes how to set BIOS configuration data

Chapter 12 Award BIOS Setup

12.1 Award BIOS Setup

The POC-153 comes with an Award BIOS chip that contains the ROM setup for your system. This chip serves as an interface between the processor and the rest of the mainboard's components. This chapter explains the information contained in the setup program and tells you how to modify the settings according to your system configuration. Some setup items will not be explained, because it is recommended that users do not change such items.

Note: Values for the various setup items that appear on your own screen (including default values) may not be the same as the values shown on the screen figures in this chapter. This is because the BIOS is revised and updated from time to time. If in doubt, check Advantech's website for the latest BIOS versions and related information.

12.2 CMOS Setup Utility

A setup program, built into the system BIOS, is stored in the CMOS RAM that allows the configuration settings to be changed. This program is executed when the user changes the system configuration; when the user changes the system backup battery; or when the system detects a configuration error and asks the user to run the setup program. At power-on RAM testing, the message "Press DEL to enter Setup" appears. After pressing the "DEL" key, the CMOS setup utility screen will appear as shown in followings. Use the arrow keys to select and press "Enter" to run the selected program.

- Use one of the arrow keys to move between options and modify the selected options by using PgUp / PgDn / + / - keys.

Date (mm:dd:yy)

The BIOS determines the day of the week from the other date information. This field is for information only. Press the left or right arrow key to move to the desired field (date, month, year). Press the PgUp or PgDn key to increment the setting, or type the desired value into the field.

Time (hh:mm:ss)

The time format is based on the 24-hour military-time clock. For example, 1 p.m. is 13:00:00. Press the left or right arrow key to move to desired field. Press the PgUp or PgDn key to increment the setting, or type the desired value into the field.

Primary / Secondary & Master / Slave

This field records the specifications for all non-SCSI hard disk drives installed in your system. Refer to the respective documentation on how to install the drives.

IDE HDD Auto-Detection	Press Enter	Item Help
IDE Primary Master Access mode	Auto Auto	Menu Level
Capacity	13022 MB	
Cylinder	25232	
Head	16	
Percomp	0	
Landing Zone	25231	
Sector	63	

Figure 12.2: Standard CMOS features

Drive A / Drive B

Select this field to the type(s) of floppy disk drive(s) installed in your system. The choices are:

360 KB, 5.25 in;

1.2 MB, 5.25 in;

720 KB, 3.5 in;

1.44 MB, 3.5 in;

2.88 MB, 3.5 in;

None.

Video

Select the type of primary video subsystem in your computer. The BIOS usually detects the correct video type automatically. The BIOS supports a secondary video subsystem, but you do not select it in setup.

Halt On

During the power-on self-test (POST), the computer stops if the BIOS detects a hardware error. You can tell the BIOS to ignore certain errors during POST and continue the boot-up process.

Select Display Device

Select this field to the display device. The choices are:

Auto

CRT

LCD

CRT+LCD

TV

CRT+TV

TV Type

Select this field to the type of TV. The choices are:

NTSC

PAL

Base Memory

Typically 640KB. Also called conventional memory. The DOS operating system and conventional applications use this area.

Extended Memory

Above the 1MB boundary. Early IBM personal computers could not use memory above 1MB, but current PCs and their software can use extended memory.

Total Memory

This option shows system memory capacity.

3. Press <ESC> to return to the Main Menu when you finish setting up all items.

12.3 Advanced BIOS Features

Advanced BIOS Features improves your system performance or sets up system features according to your preference.

Run the ADVANCED BIOS FEATURES as follows:

1. Choose “Advanced BIOS Features” from the Main Menu and a screen with a list of options will appear.
2. Use one of the arrow keys to move between options and modify the selected options by using PgUp / PgDn / + / - keys.

Virus Warning	Disabled	Item Help
CPU Internal Cache	Enabled	Menu Level
External Cache	Enabled	
CPU L2 Cache ECC Checking	Enabled	
Processor Number Feature	Enabled	
Quick Power On Self Test	Enabled	
First Boot Device	Floppy	
Second Boot Device	HDD-0	
Third Boot Device	CDROM	
Boot Other Device	Enabled	
Swap Floppy Drive	Disabled	
Boot Up Floppy Seek	Enabled	
Boot Up NumLock Status	On	
Gate A20 Option	Fast	
Typematic Rate Setting	Disabled	
Typematic Rate (Chars/Sec)	6	
Typematic Delay (Msec)	250	
Security Option	Setup	
PS/2 Mouse Function		
OS Select For DRAM > 64MB	Non-OS2	
Reports No FDD For Win95		
Video BIOS Shadow	Enabled	
C8000-CBFFF Shadow	Disabled	
CC000-CFFFF Shadow	Disabled	
D0000-D3FFF Shadow	Disabled	
D4000-D7FFF Shadow	Disabled	
D8000-DBFFF Shadow	Disabled	
DC000-DFFFF Shadow	Disabled	
Small Logo (EPA) Show		

Virus Warning

When enabled, you receive a warning message if a program (specifically, a virus) attempts to write to the boot sector or the partition table of the hard disk drive.

You should then run an antivirus program. Keep in mind that this feature protects only the boot sector, not the entire hard drive.

Note: Many disk diagnostic programs that access the boot sector table can trigger the virus warning message. If you plan to run such a program, we recommend that you disable the virus warning.

CPU Internal Cache/External Cache

Cache memory is additional memory that is much faster than conventional DRAM (system memory). CPUs from 486-type up contain internal cache memory, and most, but not all, modern PCs have additional (external) cache memory. When the CPU requests data, the system transfers the requested data from the main DRAM into cache memory, for faster access by the CPU.

CPU L2 Cache ECC Checking

When you select Enabled, it will speed up memory checking when the external cache contains ECC SRAMs. The choices: Enabled; Disabled.

Processor Number Feature

Choose Disabled or Enabled. When enabled, the processor serial number will display during the boot up screen.

Quick Power On Self Test

Select Enabled to reduce the amount of time required to run the power-on self-test (POST). A quick POST skips certain steps. We recommend that you normally enable quick POST.

First/Second/Third/Other Boot Device

The BIOS attempts to load the operating system from the devices in the sequence selected in these items. The choices: Floppy; LS/ZIP; HDD; SCSI; CDROM; Disabled.

Swap Floppy Drive

When enabled, floppy drives A and B will be exchanging without any physical connection and modification on the cables.

Boot Up Floppy Seek

When enabled, the BIOS tests (seeks) floppy drives to determine whether they have 40 or 80 tracks. Only 360-KB floppy drives have 40 tracks; drives with 270KB, 1.2MB, and 1.44MB capacity all have 80 tracks. Because very few modern PCs have 40-track floppy drives, we recommend that you set this field to disabled to save time.

Boot Up NumLock Status

Toggle between On or Off to control the state of the NumLock key when the system boots. If On, the numeric keypad is in numeric mode. If off, the numeric keypad is in cursor control mode.

Gate A20 Option

Gate A20 refers to the way the system addresses memory above 1 MB (extended memory). When set to Fast, the system chipset controls Gate A20. When set to Normal, a pin in the keyboard controller controls Gate A20. Setting Gate A20 to Fast improves system speed, particularly with OS/2 and Windows.

Typematic Rate Setting

When Disabled, the following two items (Typematic Rate and Typematic Delay) are irrelevant. Keystroke repeats at a rate determined by the keyboard controller in your system. When Enabled, you can select a typematic rate and typematic delay.

Typematic Rate (Chars / Sec)

When the typematic rate setting is enabled, you can select a typematic rate (the rate at which character repeats when you hold down a key) of 6, 8, 10, 12, 15, 20, 24, or 30 characters per second.

Typematic Delay (Msec)

Choices: 250; 500; 750; 1000. This option sets the time interval for displaying the first and the second characters. If enabled, the time interval is optional.

Security Option

If you have set a password, select whether the password is required every time the System boots, or only when you enter setup. The choices: system; setup.

PS/2 Mouse Function

Disabled: Prevents any installed PS/2 mouse from functioning but free up occupied IRQ.

Enabled: Allows the operating system to determine whether to enable or disable the mouse.

OS Select For DRAM > 64MB

Select OS2 only if you are running OS/2 operating system with greater than 64MB of RAM on your system.

Reports No FDD For Win95

Video BIOS Shadow

Performance will be improved by copying Video BIOS to Shadow RAM.

C8000-CBFFF to DC000-DFFFF Shadow

These options are used to shadow other expansion card ROMs.

Small Logo (EPA) show

3. Press <ESC> to return to the Main Menu when you finish setting up all items.

12.4 Advanced Chipset Features

Advanced Chipset Features is used to modify the values of chipset buffers. These buffers control the system options.

Run the Advanced Chipset Features as follows:

1. Choose “Advanced Chipset Features” from the Main Menu and a list of options will appear.

DRAM Timing by SPD	Enabled	Item Help
DRAM Clock	Host CLK	Menu Level
SDRAM Cycle Length	3	
Bank Interleave	Disabled	
Memory Hole	Enabled	
P2C/C2P Concurrency	Enabled	
System BIOS Cacheable	Enabled	
Video RAM Cacheable	Enabled	
Frame Buffer Size	16M	
AGP Aperture Size	64M	
APG-4X Mode	Enabled	
AGP Driving Control	Auto	
AGP Driving Value	DA	
Boot Device Select	Both	
OnChip USB	Enabled	
USB Keyboard Support	Disabled	
OnChip Sound	Enabled	
CPU to PCI Write Buffer	Enabled	
PCIDynamic Bursting	Enabled	
PCIMaster 0 WS Write	Enabled	
PCIDelay Transaction	Enabled	
PC#2 Access #1 Retry	Disabled	
AGP Master 1 WS Write	Disabled	
AGP Master 1 WS Read	Disabled	

Use one of the arrow keys to move between options and modify the selected options by using PgUp / PgDn / + / - keys.

DRAM Timing by SPD

When this item is Enabled, DRAM Timing is set by SPD. SPD (Serial Presence Detect) is located on the memory modules, BIOS reads information coded in SPD during system boot up.

DRAM Clock

This item allows you to control the DRAM speed.

The choices are : Host Clock, HCLK+33M.

SDRAM Cycle Length

Select CAS latency time in HCLKs of 2 or 3. The system designer already set the values. Do not change the default value unless you change specifications of the installed DRAM or the installed CPU.

Bank Interleave

Please use default setting. The choices: Disabled; 2 Bank; 4 Bank.

Memory Hole

In order to improve performance, certain space in memory is reserved for ISA cards. This memory must be mapped into the memory space below 16 MB. The choices: 15M-16M; Disabled.

P2C/C2P Concurrency

This item allows you to enable/disable the PCI to CPU, CPU to PCI concurrency. The choices: Enabled; Disabled.

System BIOS Cacheable

selecting Enabled allows caching of the system BIOS ROM at F0000h-FFFFFh, resulting in better system performance.

Video RAM Cacheable

Selecting Enabled allows caching of the video memory (RAM) at A0000h to AFFFFh, resulting in better video performance. However, check your AGP manual to find out if any compatibility problem exists.

Frame Buffer size

This option allows you select memory size shared to on-chip graphics.

AGP Aperture Size

Series of options are available: 4, 8, 16, 32, 64, 128 or 256 MB. Memory mapped and graphics data structures can reside in a Graphics Aperture. This area is like a linear buffer. BIOS will automatically report the starting address of this buffer to the O.S. The default setting is 64 MB.

AGP-4X Mode

This item allows you to enable AGP-4X mode. The choices are: Disabled, Enabled

AGP Driving Control

This item allows you to adjust the AGP driving force. Choose Manual to key in a AGP Driving Value in the next selection. This field is recommended to set in Auto for avoiding any error in your system. The choice: Manual, Auto.

AGP Driving Value

This item allows you to adjust the AGP driving force.

The choice: Min=0000 ~ Max=00FF.

Boot Device Select

This item allows you to select your boot display device. The choices are: Both, Auto

OnChip USB

This should be enabled if our system has a USB installed on the system board and you wish to use it. Even when so equipped, if you add a higher performance controller, you will need to disable this feature.

The choices: Enabled; Disabled.

USB Keyboard Support

Enable function when the USB keyboard is being used. When the AT keyboard is being used, choose disabled. The choices:Enabled; Disabled.

OnChip Sound

Select Enabled to use the on-chip Audio capability of your system. Most of the following field do not appear when this field is Disabled. For user who wants to use another sound card, this field must be Disabled.

CPU to PCI Write Buffer

When this field is Enabled, writes from the CPU to the PCI bus are buffered, to compensate for the speed differences between the CPU and the PCI bus. When Disabled, the writes are not buffered and the CPU must wait until the write is complete before starting another write cycle.

The choices: Enabled; Disabled.

PCI Dynamic Bursting

When Enabled, every write transaction goes to the write buffer. Bursting transactions then burst on the PCI bus and non-bursting transactions don't. The choices: Enabled; Disabled.

PCI Delay Transaction

Leave this field at default. The choice: Enabled, Disabled.

PCI Master 0 WS Write

When Enabled, writes to the PCI bus are executed with zero wait states.

The choice: Enabled, Disabled.

PCI # 2 Access # 1 Retry

Leave this field at default. The choice: Enabled, Disabled(default).

AGP Master 1 WS Write

Leave this field at default. The choice: Enabled, Disabled(default).

AGP Master 1 WS Read

Leave this field at default. The choice: Enabled, Disabled(default).

Press <ESC> to return to the Main Menu when you finish setting up all items.

12.5 Integrated Peripherals

Integrated Peripherals option allows you to get some information inside your system when it is working.

Run the INTEGRATED PERIPHERALS as follows:

1. Choose "Integrated Peripherals" from the Main Menu and a list of options will appear.
2. Use one of the arrow keys to move between options and modify the selected options by using PgUp / PgDn / + / - keys.

On-Chip IDE Channel 0	Enabled	Item Help
On-Chip IDE Channel 1	Enabled	Menu Level
IDE Prefetch Mode	Enabled	
Primary Master PIO	Auto	
Primary Slave PIO	Auto	
Secondary Master PIO	Auto	
Secondary Slave PIO	Auto	
Primary Master UDMA	Auto	
Primary Slave UDMA	Auto	
Secondary Master UDMA	Auto	
Secondary Slave UDMA	Auto	
Init Display First	PCI Slot	
IDE HDD Block Mode	Enabled	
Onboard FDD Controller	Enabled	
Onboard Serial Port 1	Auto	
Onboard Serial Port 2	Auto	
UART 2 Mode	Standard	
IR Function Duplex	Half	
TX, RX inverting enable	No, Yes	
Onboard Parallel Port	378/IRQ7	
Onboard Parallel Mode	Normal	
ECP Mode Use DMA	3	
Parallel Port EPP Type	EPP1.9	
Onboard Serial Port 3		
Serial Port 3 use IRQ		
Onboard Serial Port 4		
Serial Port 4 Use IRQ		
Onboard Legacy Audio	Enabled	
Sound Blaster	Disabled	

OnChip IDE Channel 0/1

The chipset contains a PCI IDE interface with support from two IDE channels. Select Enabled to activate the first and/or the second IDE interface. Select Disabled to inactivate an interface if you install a primary and/or second add-on IDE interface. The choices: Enabled; Disabled.

IDE Prefetch Mode

The on-board IDE drive supports IDE prefetching for faster drive accesses. If the IDE device doesn't support prefetching, set this field to Disabled. The choices: Enabled; Disabled.

Primary Master / Slave PIO & Secondary Master / Slave PIO

Choose Auto or Mode 0~4. The BIOS will detect the HDD mode type automatically when you choose Auto. You need to set to a lower mode than Auto when your hard disk becomes unstable.

The choices: Auto; Mode 0; Mode 1; Mode 2; Mode 3; Mode 4.

Primary Master / Slave UDMA & Secondary Master / Slave UDMA

Ultra DMA33/66/100 implementation is possible only if your IDE hard drive supports it, if the operating environment includes a DMA drive, and if your system software both support Ultra DMA33/66/100. Select “Auto” to enable BIOS support. The choices: Auto; Disabled.

Init Display First

Initialize the AGP video display before initializing any other display device on the system. Thus the AGP display becomes the primary display. The choices: PCI Slot; AGP.

IDE HDD Block Mode

Block mode is also called block transfer, multiple commands, or multiple sector read/write. If your IDE hard drive supports block mode (most new drives do), select Enabled for automatic detection of the optimal number of block read/write per sector the drive can support.

The choices: Enabled; Disabled.

Onboard FDD Controller

Select Enabled if your system has a floppy drive controller (FDC) installed in the system board and you want to use it. If you install add-in FDC or the system has no floppy drive, select Disabled in this field. The choices: Enabled; Disabled.

Onboard Serial Port 1 / Port2

Select an address and corresponding interrupt for the first and second serial ports.

The choices: 3F8/IRQ4; 2E8/IRQ3; 3E8/IRQ4; 2F8/IRQ3; Disabled; Auto.

UART 2 Mode

The second serial port on your system may offer a variety of infrared port modes. Click here for a description of various modes. (Click your browser’s Back button, or your right mouse button, to return to this page.)

The choices: Standard; HPSIR; ASKIR.

IR Function Duplex

This item allows you to select the IR half / full duplex function.

The choices: Half; Full.

TX, RX inverting enable

This item allows you to enable the TX, RX inverting which depends on different H/W requirement. This field is not recommended to change its default setting.

The choices: “No, No”; “No, Yes”; “Yes, No”; “Yes, Yes”.

Onboard Parallel Port

Select a logical LPT port name and matching address for the physical parallel (printer) port.

The choices: 378H/IRQ7; 278H/IRQ5; 3BC/IRQ7; Disabled.

Onboard Paralle Mode

Select an operating mode for the onboard parallel (printer) port. Select Normal, Compatible, or SPP unless you are certain your hardware and software both support one of the other available modes. The choices: SPP; EPP; ECP; ECP + EPP.

ECP Mode Use DMA

Select a DMA channel for the parallel port for use during ECP mode.

The choices: 3; 1.

Parallel Port EPP Type

Select EPP port type 1.7 or 1.9. The choices: EPP1.7; 1.9.

Onboard Legacy Audio

This field controls the on-board audio.

- Sound Blaster
- SB I/O Base Address
- SB IRQ Select
- SB DMA Select
- MPU-401
- MPU-401 I/O Address
- Game Port (200-207H)

3. Press <ESC> to return to the Main Menu when you finish setting up all items.

12.6 Power Management Setup

POWER MANAGEMENT SETUP allows you to set the system's power saving functions.

Run the POWER MANAGEMENT SETUP as follows:

1. Choose "Integrated Peripherals" from the Main Menu and a list of options will appear.
2. Use one of the arrow keys to move between options and modify the selected options by using PgUp / PgDn / + / - keys.

ACPI Function	Disabled	Item Help
Power Management	Press Enter	Menu Level
PM Control by APM	Yes	
Video Off Option	Suspend --> Off	
Video Off Method	V/H SYNC+Blank	
MODEM Use IRQ	3	
Soft-Off by PWRBTN	Instand-Off	
Wake Up Events	Press Enter	

ACPI Function

Select Enabled only if your computer's operating system supports the Advanced Configuration and Power Interface (ACPI) specification. Currently, Windows NT 5.0 supports ACPI.

Power Management

When this option is chosen, the following item appears for user's configuration.

Power Management	User Define	Item Help
HDD Power Down	Disable	Menu Level
Doze Mode	Disable	
Suspend Mode	Disable	

- **Power Management:** This option allows you to select the type (or degree) of power saving for Doze, Standby, and Suspend modes. This table describes the power management modes for your reference:

Max Saving	Maximum power savings. Only Available for SL CPUs. Inactivity period is 1 minute in each mode.
User Define	Set each mode individually. Select time-out period in the section for each mode stated below.
Min Saving	Minimum power savings. Inactivity period is 1 hour in each mode (except the hard drive).

- **HDD Power Down:** When enabled and after the set time of system inactivity, the hard disk drive will be powered down while all other devices remain active.
- **Suspend Mode:** After the selected period of system inactivity, the chipset enters a hardware suspend mode, stopping the CPU clock and possibly causing other system devices to enter power management modes.
- **Doze Mode:** After the selected period of system inactivity, the CPU clock runs at slower speed while all other devices still operate at full speed.

PM Control by APM

If Advanced Power Management (APM) is installed on your system, selecting “Yes” gives better power savings. The Choices: Yes; No.

Video Off Option

When enabled, this feature allows the VGA adapter to operate in a power saving mode.

Always On	Monitor will remain on during power saving modes.
Suspend → Off	Monitor blanked when the systems enters the Suspend mode.
All Modes → Off	Monitor blanked when the system enters either Suspend or Standby modes.

Video Off Method

This determines the manner in which the monitor is blanked.

V/H SYNC + Blank	This selection will cause the system to turn off the vertical and horizontal synchronization ports and write blanks to video buffer.
Blank Screen	This option only writes blanks to the video buffer.
DPMS Supports	Select this option if you monitor supports the Display Power Management Signaling (DPMS) standard of the Video Electronics Standards to select video power management values.

MODEM Use IRQ

This determines the IRQ which the MODEM can use.

The choices: 3; 4; 5; 7; 9; 10; 11; NA.

Soft-Off by PWRBTN

When Enabled, turning the system off with the on/ off button places the system in a very low-powerusage state, with only enough circuitry receiving power to detect power button activity or Resume by Ring activity.

WAKE UP EVENTS

When this option is chosen, the following item appears for user's configuration.

VGA	Off	Item Help
LPT & COM	LPT/COM	Menu Level
HDD & FDD	On	
PCIMaster	Off	
IRQs Activity		
Monitoring	Press Enter	

- **VGA:** When Enabled, you can set the VGA awakens the system.
- **LPT & COM:** When LPT & COM is ON, any activity from one of the listed system peripheral devices or IRQs wakes up the system.
- **HDD & FDD:** When HDD & FDD is ON, any activity from one of the listed system peripheral devices wakes up the system.
- **PCI Master:** When PCI Master is ON, any activity from one of the listed system peripheral devices wakes up the system.

- **Primary INTR:** When set to on, any event occurring at will awaken a system which has been powered down.

On(default):The system can not enter the power saving mode when I/O ports or IRQ# is activated. Off:The system still can enter the power saving mode when I/O ports or IRQ# is activated.

- **IRQ Activity Monitoring:** The following is a list of IRQ's (Interrupt Requests), which can be exempted much as the COM ports and LPT ports above can. When an I/O device wants to gain the attention of the operating system, it signals this by causing an IRQ to occur. When the operating system is ready to respond to the request, it interrupts itself and performs the service. When set On, activity will neither prevent the system from going into a power management mode nor awaken it.

When this option is chosen, the following item appears for user's configuration.

IRQ-3 (COM2)	Enabled	Item Help
IRQ-4 (COM1)	Enabled	Menu Level
IRQ-5 (LPT2)	Enabled	
IRQ-6 (Floppy Disk)	Enabled	
IRQ-7 (LPT1)	Enabled	
IRQ-8 (RTC Alarm)	Disabled	
IRQ-9 (IRQ2 Redir)	Disabled	
IRQ-10 (Reserved)	Disabled	
IRQ-11 (Reserved)	Disabled	
IRQ-12 (PS/2 Mouse)	Enabled	
IRQ 13 (Coprocessor)	Disabled	
IRQ 14 (Hard Disk)	Enabled	
IRQ 15 (Reserved)	Disabled	

3. Press <ESC> to return to the Main Menu when you finish setting up all items.

12.7 PnP/PCI Configuration

PnP/PCI Configuration allows you to modify the system's power saving functions.

Run the PnP/PCI Configuration as follows:

1. Choose "PnP/PCI Configuration" from the Main Menu and a list of options will appear.
2. Use one of the arrow keys to move between options and modify the selected options by using PgUp / PgDn / + / - keys.

PNP OS Installed	No	Item Help
Reset Configuration Data	Disabled	Menu Level
Resources Controlled By	Auto(ESCD)	
IRQ Resources	Press Enter	
DMA Resources	Press Enter	
PCI/VGA Palette Snoop	Disabled	
Assign IRQ For VGA	Enabled	
Assign IRQ For USB	Enabled	

PNP OS Installed

Select Yes if the system operating environment is Plug-and-Play aware (e.g. Windows 95).

Note: *BIOS will automatically disable all PnP resources except the boot device card when you select Yes on Non-PnP operating system.*

Reset Configuration Data

Normally, you leave this Disabled. Select Enabled to reset Extended System Configuration Data (ESCD), when you exit Setup if you have installed a new add-on and the system reconfiguration has caused such a serious conflict that the operating system cannot boot.

Resource Controlled By

The Plug and Play Award BIOS can automatically configure all the boot and Plug and Play-compatible devices. If you select Auto, all the interrupt request (IRQ) and DMA assignment fields disappear, as the BIOS automatically assigns them.

IRQ Resources

Press Enter. Please refer to the list below:

IRQ -9 assigned to	P C I / I S A P n P	Item Help
		Menu Level

DMA Resources

Press Enter. Please refer to the below list.

DMA-0 assigned to	PCI/ISA PnP	Item Help
DMA-1 assigned to	PCI/ISA PnP	Menu Level
DMA-3 assigned to	PCI/ISA PnP	
DMA-5 assigned to	PCI/ISA PnP	
DMA-6 assigned to	PCI/ISA PnP	
DMA-7 assigned to	PCI/ISA PnP	

PCI/VGA Palette Snoop

This option allows the BIOS to preview VGA status, and to modify the information delivered from the feature Connector of the VGA card to MPEG card. This option can solve the display inversion to black after you have used MPEG card.

Assign IRQ for VGA

Select Enabled if you system has a VGA controller and you have one or more USB devices connected. If you are not using your system's VGA controller, select Disabled to free the IRQ resource.

Assign IRQ for USB

Select Enabled if you system has a USB controller and you have one or more USB devices connected. If you are not using your system's USB controller, select Disabled to free the IRQ resource.

3. Press <ESC> to return to the Main Menu when you finish setting up all items.

12.8 PC Health Status

This section helps you to get more information about your system including CPU temperature, FAN speed and voltage. It is recommended that you contact your mainboard supplier to get proper values about the setting of the CPU temperature.

Run the PC Health Status as follows:

1. Choose “PC Health Status” from the Main Menu and a list of options will appear.
2. Use one of the arrow keys to move between options and modify the selected options by using PgUp / PgDn / + / - keys.

Current CPUFAN1 Speed	Item Help
Current CPUFAN2 Speed	Menu Level
Vcore	
2.5V	
3.3V	
5V	
12V	

Current CPU FAN1 Speed

Shows current CPU FAN1 speed. The fan must provide rotary pulse. (Normally these types of fan have a three-wire connector)

Current CPU FAN2 Speed

Shows current CPUFAN2 speed. The fan must provide rotary pulse. (Normally these types of fan have a three-wire connector)

Vcore/2.5V/3.3V/5V/1.2V

Shows power supply actual voltage value.

12.9 Frequency/Voltage Control

Run the Frequency/Voltage Control as follows:

1. Choose “Frequency/Voltage Control” from the Main Menu and a list of options will appear.
2. Use one of the arrow keys to move between options and modify the selected options by using PgUp / PgDn / + / - keys.

Auto Detect DIMM/PCI CLK	Enabled	Item Help
Spread Spectrum	Enabled	Menu Level

Auto Detect DIMM/PCI CLK

To reduce the occurrence of electromagnetic interference (EMI), the BIOS detects the presence or absence of components in DIMM and PCI slots and turns off system clock generator pulses against empty slots.

Spread Spectrum

When the system clock generator pulses, the extreme values of the pulse generate excess EMI. Enabling pulse spectrum spread modulation changes the extreme values from spikes to flat curves, thus reducing EMI. This benefit may in some cases be outweighed by problems with timing-critical devices, such as a clock-sensitive SCSI device.

12.10 Load Optimized Defaults

When you press <Enter> on this item, you will get a confirmation dialog box with a message similar to:

“ Load Optimized Defaults (Y/N) ? N ”

“Y” is for “Yes”, and “N” is for “No”.

Pressing “Y” loads the BIOS default values that are factor settings for optimal performance of system operations.

12.11 Set Password

These option allows you to set your system passwords. The way to set up the password is as follows:

1. Choose “Change Password” in the Main Menu and press <Enter>. Then following message appears:
“Enter Password : “
2. The first time you run this option, enter your password up to 8 characters and press <Enter>. (The screen does not display the entered characters.)
3. After you enter the password, the following message appears prompting you to confirm the password:
“Confirm Password : “
4. Enter the same password “exactly” the same as you have just typed to confirm the password and press <Enter>.
5. Move the cursor to Save & Exit Setup to save the password.
6. If you need to delete the password entered before, choose the Supervisor Password and press <Enter>. It will delete the password that you have entered before.
7. Move the cursor to Save & Exit Setup to save the option you have just configured; otherwise the old password will still be there the next time you turn your system on.
8. Press <Enter> to exit to the Main Menu.

Note: *If you forget or lose the password, the only way to access the system is to clear the CMOS RAM. All setup informations will be lost and you need to run the BIOS setup program again.*

12.12 Save & Exit Setup

Save & Exit Setup allows you to save all modifications you have specified into the CMOS memory. Highlight this option on the Main Menu and the following message appears:

“Save to CMOS and Exit (Y/N) ? Y “

“Y” is for “Yes”, and “N” is for “No”.

Press <Enter> key to save the configuration changes.

12.13 Exit Without Saving

Exit Without Saving option allows you to exit the Setup Utility without saving the modifications that you have specified. Highlight this option on the Main Menu and the following message appears:

“Quit Without Saving (Y/N) ? N “

“Y” is for “Yes”, and “N” is for “No”.

You may change the prompt to “Y” and press <Enter> key to leave this option .

Appendix

A

LCD Specifications and Selection Settings

Appendix A LCD Specifications

A.1 POC-153T LCD Specifications

Display type: 15" TFT LCD

Max. resolution: 1024 x 768

Colors: 256 K or above

Dot size (mm): 0.297 x 0.297

Viewing angle: 140°

Luminance: 350 cd/m²

Temperature: 0 ~ 50° C

***VR control:** Brightness

Simultaneous mode: Yes

LCD MTBF: 50,000 hours

Backlight MTBF: 25,000 hours

* The VR control knob is located in the I/O section on the rear side of the panel PC.

Note: The color LCD display installed in the POC-153 is high-quality and reliable. However, it may contain a few defective pixels which do not always illuminate. With current technology, it is impossible to completely eliminate defective pixels. Advantech is actively working to improve this technology.

Programming the Watchdog Timer

The POC-153 is equipped with a watchdog timer that resets the CPU or generates an interrupt if processing comes to a standstill for any reason. This feature ensures system reliability in industrial standalone or unmanned environments.

Appendix B Programming the Watchdog Timer

B.1 Programming the Watchdog Timer

To program the watchdog timer, you must write a program which writes I/O port address 443 (hex). The output data is a time interval value. The value range is from 01 (hex) to 3E (hex), and the related time interval is from 1 sec. to 62 sec.

Data Time Interval

01 1 sec.

02 2 sec.

03 3 sec.

04 4 sec.

• •

• •

• •

3E 62 sec.

After data entry, your program must refresh the watchdog timer by rewriting the I/O port 443 (hex) while simultaneously setting it. When you want to disable the watchdog timer, your program should read I/O port 443 (hex).

The following example shows how you might program the watchdog timer in BASIC:

```
10  REM Watchdog timer example program
20  OUT &H443, data REM Start and restart the watchdog
30  GOSUB 1000 REM Your application task #1,
40  OUT &H443, data REM Reset the timer
50  GOSUB 2000 REM Your application task #2,
60  OUT &H443, data REM Reset the timer
70  X=INP (&H443) REM, Disable the watchdog timer
80  END

1000 REM Subroutine #1, your application task
.      .
.      .
.      .

1070 RETURN

2000 REM Subroutine #2, your application task
.      .
.      .
.      .

2090 RETURN
```

Appendix

C

Full Disassembly Procedures

Appendix C Full Disassembly Procedures

If you want to completely disassemble the panel PC, follow the step-by-step procedures below. Users should be aware that Advantech Co., Ltd. takes no responsibility whatsoever for any problems or damage caused by the user disassembly of the panel PC. Make sure the power cord of the panel PC is unplugged before you start disassembly.

The following procedures do not include the detailed disassembly procedures for the CPU, HDD, CD-ROM drive, FDD, and SRAM; all of which can be found in Chapter 4.

1. Unscrew the seven screws on the rear cover, and remove it. The PCI/ISA expansion slot cover can be detached by removing the two additional screws.
2. Remove the side panel by pushing it outward.
3. Unscrew the four screws that attach the CPU cover.
4. Detach the flat cable of the HDD, FDD and CD-ROM drive. Remove the two screws on the PCI/ISA bus expansion card. Remove the ten screws on the side rim of the shielding case. Carefully move the shielding case to the right to bypass the eject buttons of the PCMCIA slot, before removing the case from the machine.

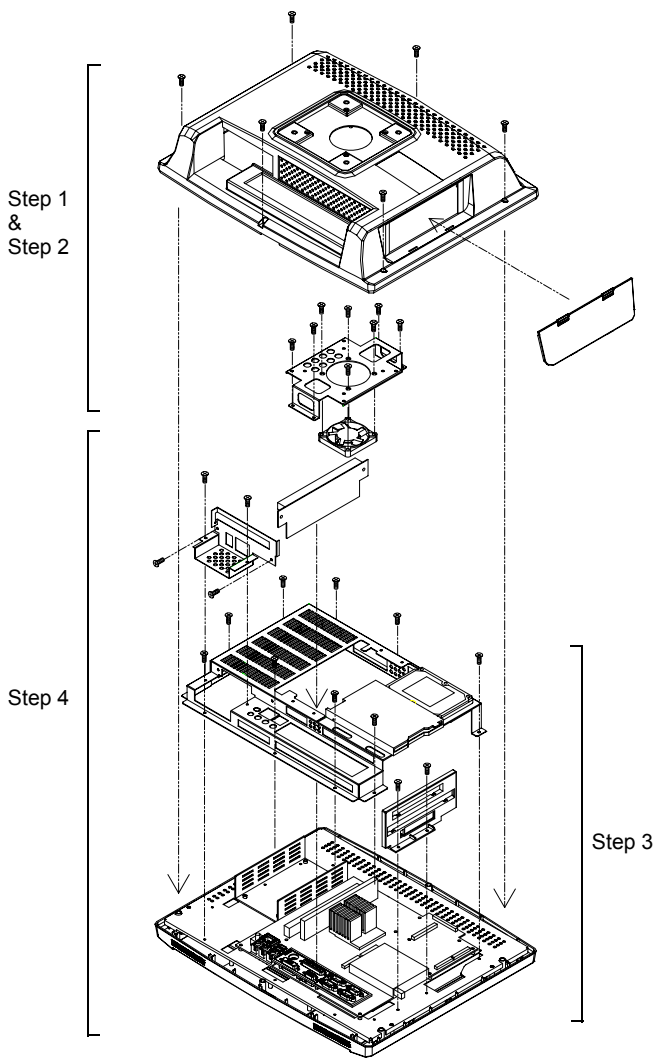

Figure C.1: Disassembly steps 1 - 4

5. Unscrew the fourteen screws of the I/O bracket with a hexagonal screwdriver. The EMI protection cover lies below the I/O bracket. You can now remove both the bracket and the cover from the I/O ports.
6. Detach the flat cables of the LCD inverter, touchscreen and LCD from the motherboard. You can remove the motherboard from the plastic housing.

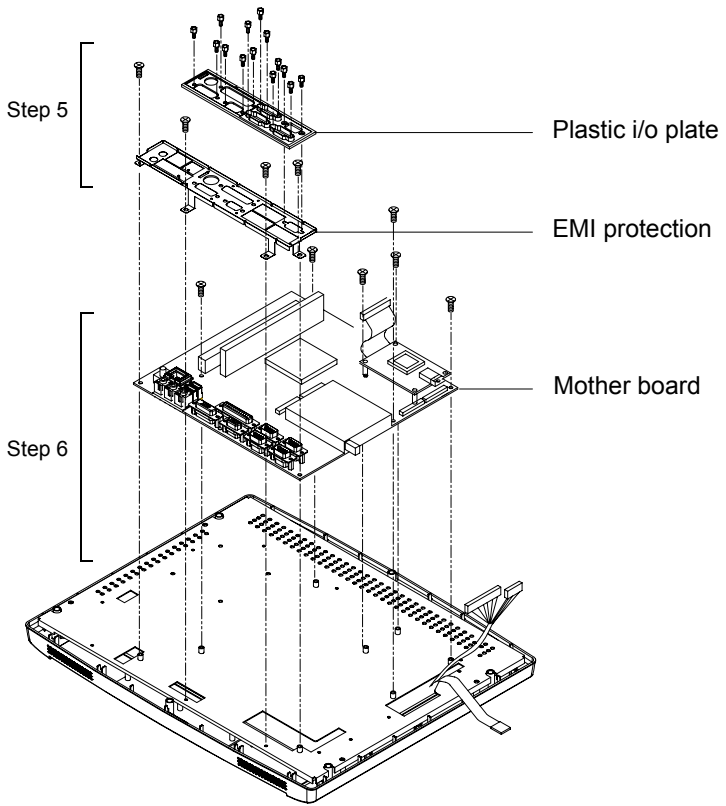

Figure C.2: Disassembly steps 5 - 6

7. Unscrew the four screws on the power supply board. The power supply board can be detached from the plastic housing after unplugging the cables from the motherboard.
8. Remove the front panel by hand.
9. Unscrew the ten screws on the LCD holding plate to separate the plastic housing and LCD holding plate. The LCD inverter can also be detached by unscrewing the three screws at the bottom (Toshiba LCD only).
10. Detach the plastic housing.
11. Detach the LCD by unscrewing the four screws located on the each corners.
12. The touchscreen is stuck on the LCD holding plate by a strongly double-side adhesive tape. We do not recommend you to remove it unless the touchscreen is defective and you would like to replace it.

Note: *Because of the modular design of the LCD and touchscreen, you do not disassemble the whole system step by step if you would like to replace the defective LCD or touchscreen. You just start disassembling the module from the step 8. Then you can easily remove the LCD and touchscreen by step 9 to step 12.*

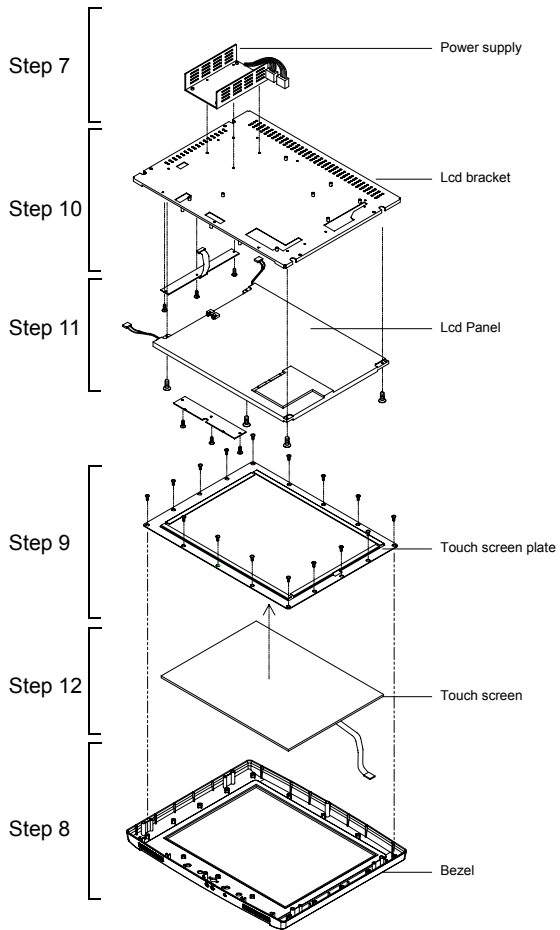

Figure C.3: Disassembly steps 7 - 12

I/O Pin Assignments

- AT Power Connector (J1)
- TV Output Connector (J11) (*Reserved)
- Inverter Power Connector (J4)
- Internal Speaker Connector (J6) (Reserved)
- Front Panel Control Connector (J8) (Reserved)
- IR Connector (J9) (Reserved)
- Flat Panel Display Connector (CN2)
- Flat Panel Display Connector (CN3)
- Floppy Drive Connector (CN10)
- EIDE Hard Disk Drive Connector (CN16)
- CD-ROM Connector (CN18)
- CPU Fan Power Connector (FAN1)
- System Fan Power Connector (FAN2)
- PCI/ISA Expansion Connector (SLOT1)
- Internal COM4 and PS/2 connector (CN23)
- COM2

Appendix D Pin Assignments

D.1 AT Power connector (J1)

Table D.1: Table D-1: AT power connector (J1)

Pin	Signal
1	PS_NO #
2	+5 VSB
3	+12 V
4	-12 V
5	GND
6	GND
7	GND
8	GND
9	-5 V
10	+5 V
11	+5 V
12	+5 V

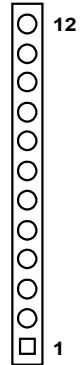

D.2 TV Output Connector (J11) (*Reserved)

Table D.2: Table D-2: TV output connector (J11)

Pin	Signal
1	Y
2	C
3	GND
4	GND
5	CVBS

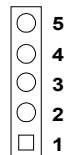

D.3 Inverter Power Connector (J4)

Table D.3: Inverter power connector (J4)

Pin	Signal
1	+12 V
2	GND
3	ENABKL
4	Brightness Adj.
5	+5 V

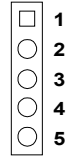

D.4 Internal Speaker Connector (J6) (*Reserved)

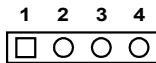

Table D.4: Internal speaker connector (J6)

Pin	Signal
1	Speaker out_R -
2	Speaker out_R +
3	Speaker out_L +
4	Speaker out_L -

D.5 Front Panel Control Connector (J8) (*Reserved)

Table D.5: Front panel control connector (J8)

Pin	Signal
1	Vcc
2	GND
3	HDD LED
4	Reset SW
5	Power SW
6	GND

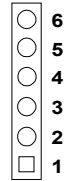

D.6 IR Connector (J9) (*Reserved)

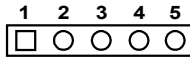

Table D.6: IR connector (J9) (Reserved)

Pin	Signal
1	VCC
2	NC
3	IR_IN
4	GND
5	IR_OUT

D.7 Flat Panel Display Connector (CN2)

Table D.7: Flat panel display connector (CN2)

Pin	Signal	Pin	Signal
1	VDDSAFE5	2	VDDSAFE5
3	GND	4	GND
5	VDDSAFE3	6	VDDSAFE3
7	Vcon	8	GND
9	P0	10	P1
11	P2	12	P3
13	P4	14	P5
15	P6	16	P7
17	P8	18	P9
19	P10	20	P11
21	P12	22	P13
23	P14	24	P15
25	P16	26	P17
27	P18	28	P19
29	P20	30	P21
31	P22	32	P23
33	GND	34	GND
35	SHFCLK	36	FLM
37	M/DE	38	LP
39	ENABKL	40	ENAVEE

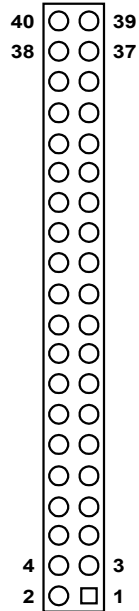

D.8 Flat Panel Display Connector (CN3)

Table D.8: Flat panel display connector (CN3)

Pin	Signal	Pin	Signal
1	VDDSAFE5	2	VDDSAFE5
3	GND	4	GND
5	VDDSAFE3	6	VDDSAFE3
7	Vcon	8	GND
9	P24	10	P25
11	P26	12	P27
13	P28	14	P29
15	P30	16	P31
17	P32	18	P33
19	P34	20	P35
21	NC	22	NC
23	NC	24	NC
25	NC	26	NC
27	NC	28	NC
29	NC	30	NC
31	NC	32	NC
33	GND	34	GND
35	NC	36	NC
37	NC	38	NC
39	NC	40	NC

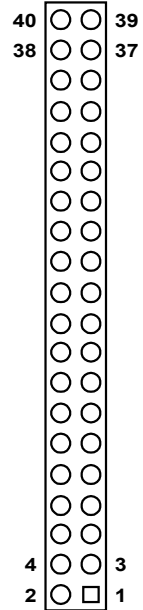

D.9 Floppy Drive Connector (CN10)

Table D.9: Floppy drive connector (CN10)

Pin	Signal	Pin	Signal
1	+5 V	14	STEP
2	INDEX	15	GND
3	+5 V	16	WRITE DATA
4	DRIVE SELECT	17	GND
5	+5 V	18	WRITE ENABLE
6	DISK CHANGE	19	GND
7	NC	20	TRACK 0
8	NC	21	GND
9	NC	22	WRITE PRO- TECT
10	MOTOR ON	23	GND
11	NC	24	READ DATA
12	DIRECTION	25	GND
13	NC	26	HEAD SELECT

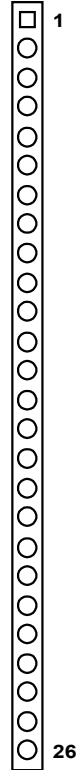

D.10 EIDE Hard Disk Drive Connector (CN16)

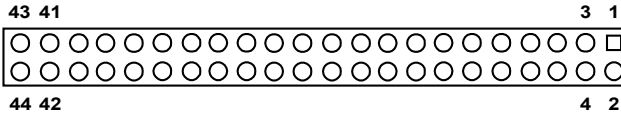

Table D.10: EIDE hard disk drive connector (CN16)

Pin	Signal	Pin	Signal
1	IDE RESET #	2	GND
3	DATA 7	4	DATA 8
5	DATA 6	6	DATA 9
7	DATA 5	8	DATA 10
9	DATA 4	10	DATA 11
11	DATA 3	12	DATA 12
13	DATA 2	14	DATA 13
15	DATA 1	16	DATA 14
17	DATA 0	18	DATA 15
19	GND	20	NC
21	HDD DREQ	22	GND
23	IO WRITE	24	GND
25	IO READ	26	GND
27	HDD READY	28	CABLE SELECT
29	HDACK #	30	GND
31	IRQ14	32	NC
33	ADDR 1	34	NC
35	ADDR 0	36	ADDR 2
37	HDD SELECT 0 #	38	HDD SELECT 1 #
39	HDD ACTIVE #	40	GND
41	+5V	42	+5V
43	GND	44	NC

low active

D.11 CD-ROM Connector (CN18)

Table D.11: CD-ROM connector (CN18)

Pin	Signal	Pin	Signal
1	Audio_L	2	Audio_R
3	CDGND	4	GND
5	IDE RESET #	6	DATA8
7	DATA7	8	DATA9
9	DATA6	10	DATA10
11	DATA5	12	DATA11
13	DATA4	14	DATA12
15	DATA3	16	DATA13
17	DATA2	18	DATA14
19	DATA1	20	DATA15
21	DATA0	22	HDD DREQ
23	GND	24	IO READ
25	IO WRITE	26	GND
27	HDD READY	28	HD ACK
29	IRQ 15	30	HDD ACTIVE
31	ADDR1	32	NC
33	ADDR0	34	ADDR2
35	HDD SELECT 0 #	36	HDD SELECT 1 #
37	+5V	38	+5V
39	GND	40	GND

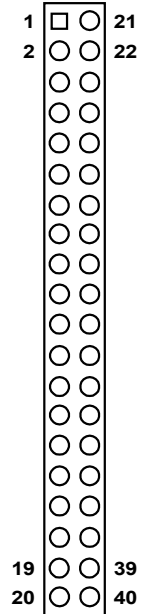

low active

D.12 CPU Fan Power Connector (FAN1)

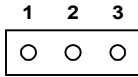

Table D.12: CPU fan power connector (FAN1)

Pin	Signal
1	GND
2	+12 V
3	FAN_DET

D.14 System Fan Power Connector (FAN2)

D.13 Fan power connector (FAN2)

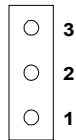

Table D.13: Fan power connector (FAN2)

Pin	Signal
1	GND
2	+12 V
3	FAN_DET

D.14 PCI/ISA Bus Expansion Connector (SLOT1)

Side view

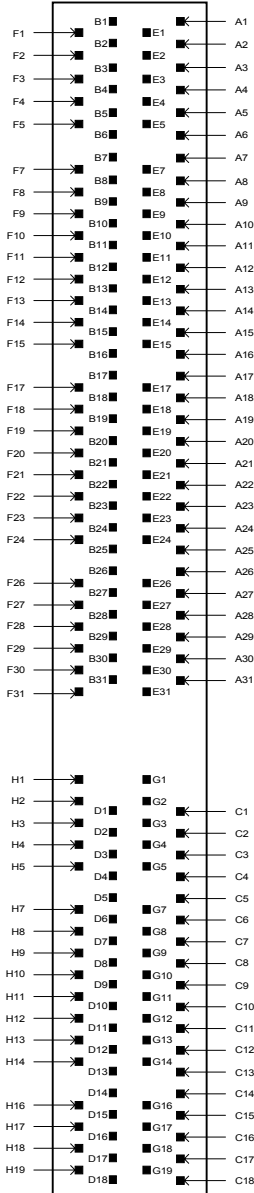

Table D.14: PCI/ISA pin assignments (Pins A & B)

Pin	Signal	Pin	Signal
A1	IOCHK	B1	GND
A2	SD7	B2	ISARST
A3	SD6	B3	+5V
A4	SD5	B4	IRQ9
A5	SD4	B5	-5V
A6	SD3	B6	DRQ2
A7	SD2	B7	-12 V
A8	SD1	B8	OWS
A9	SD0	B9	+12 V
A10	IORDY	B10	GND
A11	AEN	B11	SMW
A12	SA19	B12	SMR
A13	SA18	B13	IOW
A14	SA17	B14	IOR
A15	SA16	B15	DACK3
A16	SA15	B16	DRQ3
A17	SA14	B17	DACK1
A18	SA13	B18	DRQ1
A19	SA12	B19	RFSH
A20	SA11	B20	ISACK
A21	SA10	B21	IRQ7
A22	SA9	B22	IRQ6
A23	SA8	B23	IRQ5
A24	SA7	B24	IRQ4
A25	SA6	B25	IRQ3
A26	SA5	B26	DACK2
A27	SA4	B27	TC
A28	SA3	B28	ALE
A29	SA2	B29	+5V
A30	SA1	B30	ISAOSC
A31	SA0	B31	GND

Pin	Signal	Pin	Signal
C1	SBHE	D1	MEM16
C2	LA23	D2	IO16
C3	LA22	D3	IRQ10
C4	LA21	D4	IRQ11
C5	LA20	D5	IRQ12
C6	LA19	D6	IRQ15
C7	LA18	D7	IRQ14
C8	LA17	D8	DACK0
C9	MEMR	D9	DRQ0
C10	MEMW	D10	DACK5
C11	SD8	D11	DRQ5
C12	SD9	D12	DACK6
C13	SD10	D13	DRQ6
C14	SD11	D14	DACK7
C15	SD12	D15	DRQ7
C16	SD13	D16	+5V
C17	SD14	D17	MASTER
C18	SD15	D18	GND

Table D.16: PCI/ISA pin assignments (Pins E & F)

Pin	Signal	Pin	Signal
E1	GND	F1	GND
E2	GND	F2	GND
E3	INT 1	F3	INT3
E4	INT 2	F4	INT4
E5	+5V	F5	+5V
E6	---	F6	---
E7	+5V	F7	+5V
E8	RST	F8	PCICLK2
E9	GNT1	F9	GND
E10	REQ1	F10	GNTX
E11	GND	F11	GND
E12	PCICLK1	F12	REQX
E13	GND	F13	AD31
E14	AD30	F14	AD29
E15	REQ3	F15	NC
E16	---	F16	---
E17	GNT3	F17	NC
E18	AD28	F18	AD27
E19	AD26	F19	AD25
E20	AD24	F20	C/BE3
E21	AD22	F21	AD23
E22	AD20	F22	AD21
E23	AD18	F23	AD19
E24	NC	F24	PME
E25	---	F25	---
E26	---	F26	VS3.3V
E27	AD16	F27	AD17
E28	FRAME	F28	IRDY
E29	C/BE2	F29	DEVSEL
E30	TRDY	F30	LOCK
E31	STOP	F31	PERR

Pin	Signal	Pin	Signal
G1	---	H1	SERR
G2	---	H2	AD15
G3	CBE1	H3	AD14
G4	PAR	H4	AD12
G5	GND	H5	GND
G6	---	H6	---
G7	GND	H7	GND
G8	AD13	H8	AD10
G9	AD11	H9	AD8
G10	AD9	H10	AD7
G11	CBEO	H11	AD5
G12	AD6	H12	AD3
G13	AD4	H13	AD1
G14	AD2	H14	AD0
G15	---	H15	---
G16	VCC	H16	+5V
G17	VCC	H17	+5V
G18	GND	H18	GND
G19	GND	H19	GND

D.15 Touchscreen Connector (CN23)

Table D.18: Internal COM4 and PS/2 Conn. (CN23)

Pin	Signal	Pin	Signal
1	NRLSD	2	NDSR
3	NRX	4	NRTS
5	NTX	6	NCTS
7	NDTR	8	NRI
9	GND	10	GND
11	MSDAT	12	EXT MSDAT
13	MSCLK	14	EXT MSCLK
15	+5V	16	+5V

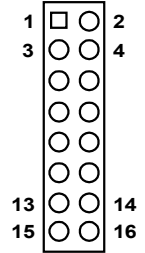

D.16 USB3 Connector (JP7)

Table D.19: USB3 Connector (JP7)

Pin	Signal	Pin	Signal
1	+5V		
2	USB3_DATA+		
3	USB3_DATA-		
4	GND		

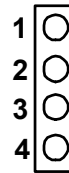

D.17 COM2 (CN12)

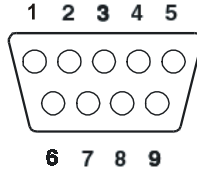

Table D.20: COM2 (CN12)

Pin	Signal	RS-422	RS-485I
1	DCD	TX-	DATA-
2	RX	TX+	DATA+
3	TX	RX+	
4	DTR	RX-	
5	GND	GND	
6	DSR		
7	RTS		
8	CTS		
9	RI (RI/+5V/+12V)		

D.18 COM3 RS-232 serial port (CN13)

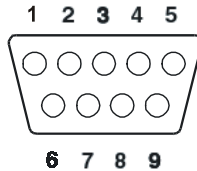

Table D.21: COM3 RS-232 serial port (CN13)

Pin	Signal	Pin	Signal
1	DCD	2	RXD
3	TxD	4	DTR
5	GND	6	DSR
7	RTS	8	CTS
9	RI (RI/+5V/+12V)		

D.19 COM4 RS-232 serial port (CN14)

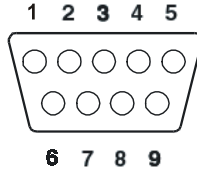

Table D.22: COM1 RS-232 serial port (CN14)

Pin	Signal	Pin	Signal
1	DCD	2	RXD
3	TxD	4	DTR
5	GND	6	DSR
7	RTS	8	CTS
9	RI (RI/+5V/+12V)		

D.20 Keyboard & PS/2 Mouse connector (CN22)

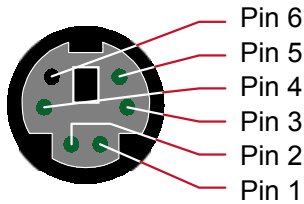

Table D.23: COM1 RS-232 serial port (CN14)

Pin	Signal	Pin	Signal
1	KB-DAT	2	MS-DAT
3	GND	4	+5 V
5	KB-CLK	6	MS-CLK

D.21 Parallel port (CN9)

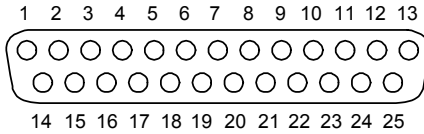

Table D.24: Parallel port (CN9)

Pin	Signal	Pin	Signal
1	Strobe	2	D0
3	D1	4	D2
5	D3	6	D4
7	D5	8	D6
9	D7	10	ACK
11	BUSY	12	PE
13	SLCT	14	AUTOFD
15	ERR	16	INIT
17	SLTCTINI	18	GND
19	GND	20	GND
21	GND	22	GND
23	GND	24	GND
25	GND		

D.22 Keyboard & PS/2 Mouse connector (CN22)

Table D.25: USB1/USB2 (CN19/CN20)

USB1 (CN19)		USB2 (CN20)	
Pin	Signal	Pin	Signal
1	+5 V	1	+5 V
2	DATA-	2	DATA-
3	DATA+	3	DATA+
4	GND	4	GND

Mounting Instructions

- Introduction
- Panel Mounting
- Desktop Stand Mounting
- Swingarm Stand Mounting

Appendix E Pin Assignments

E.1 Introduction

The POC-153 can be placed as is on a shelf or table, mounted into a panel, or mounted on a customized swingarm or desktop stand.

E.2 Desktop Stand Mounting

The POC-153 series of products customized stand is suitable for desktop and other horizontal locations.

A unique spring inside the stand enables the Point-of-Care vertical tilt to be adjusted about 30 degree.

Your desktop stand package should contain one of each of the following:

Main body bkt adapter for mounting base, top cover, rear cover of stand, packet of screws and two caps

Follow these procedures to set up the stand:

1. First, fix the BKT-ADAPTER-FOR-MOUNTING to the rear-cover of POC-153 series ,using four M4x20L screws provided in accessory box of POC-15 series.
2. Attach the arms of the main body of the stand to holding-plate of the rear cover of the POC-153 series, using the four M4x5L screws provided.
3. Slide the main body of the stand into the stand base. The bottom plates of the main body should slide perfectly over the back plate of the base. Fasten the main body to the base with two M4x8L flat-head screws provided.
4. Attach the rear cover of the stand to the main body of the stand by snapping the lugs of the rear cover into the slots the main body. When the rear cover locks into place, you will hear a click.
5. Attach the top cover of the stand to the main body of the stand by snapping the lugs of the top cover into the slots of the main body. The cover must be rotated as it is snapped into place. When the top cover locks into place, you will hear a click.

Note: The base of the stand has two plastic caps. If you pry off the caps, you can attach the stand to your desktop using the two holes. .

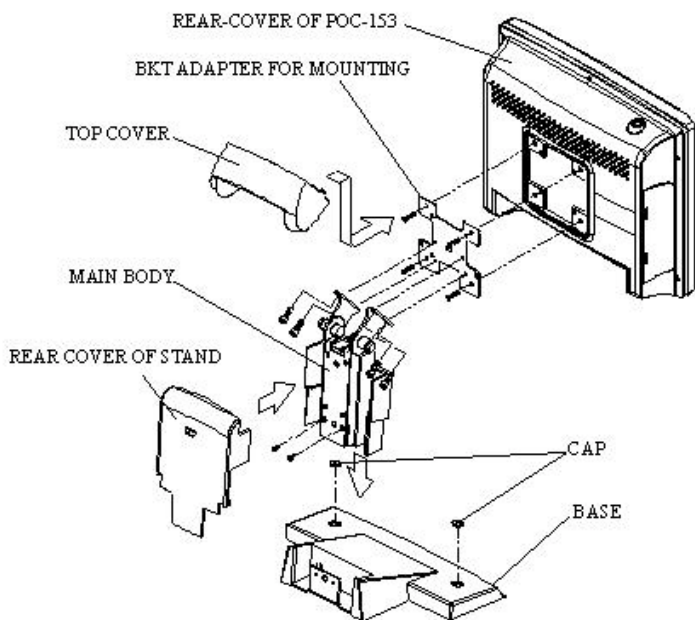
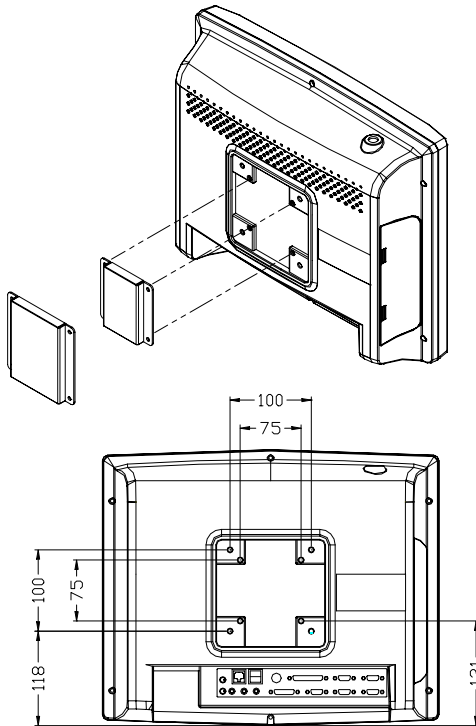

Figure E.1: Desktop stand mounting

E.3 Swingarm Stand Mounting

The POC-153 can be mounted on a unique swingarm. This versatile accessory is easy to install and operate, and can be rotated through a wide range of angles. Its dimensions are shown in Figure E-2 below, and it is available from Advantech Co., Ltd.



Units:mm

Figure E.2: Swingarm stand mounting