

PCM-9580

**Socket 478 Pentium IV SBC with
VGA, LVDS, Ethernet, Audio, &
USB 2.0**

Users' Manual

Copyright

This document is copyrighted, © 2003. All rights are reserved. The original manufacturer reserves the right to make improvements to the products described in this manual at any time without notice.

No part of this manual may be reproduced, copied, translated or transmitted in any form or by any means without the prior written permission of the original manufacturer. Information provided in this manual is intended to be accurate and reliable. However, the original manufacturer assumes no responsibility for its use, nor for any infringements upon the rights of third parties that may result from such use.

Acknowledgements

Award is a trademark of Award Software International, Inc.

VIA is a trademark of VIA Technologies, Inc.

IBM, PC/AT, PS/2 and VGA are trademarks of International Business Machines Corporation.

Intel and Pentium are trademarks of Intel Corporation.

Microsoft Windows® is a registered trademark of Microsoft Corp.

RTL is a trademark of Realtek Semi-Conductor Co., Ltd.

ESS is a trademark of ESS Technology, Inc.

UMC is a trademark of United Microelectronics Corporation.

SMI is a trademark of Silicon Motion, Inc.

Creative is a trademark of Creative Technology LTD.

CHRONTEL is a trademark of Chrontel Inc.

All other product names or trademarks are properties of their respective owners.

For more information on this and other Advantech products, please visit our websites at: <http://www.advantech.com>

<http://www.advantech.com/epc>

For technical support and service, please visit our support website at:

<http://support.advantech.com>

This manual is for the PCM-9580.

Part No. 2006958014

5th Edition, Printed May 2004

Packing List

Before you begin installing your card, please make sure that the following materials have been shipped:

- 1 PCM-9580 all-in-one single board computer
- 1 CD disk for utility and drivers
- 1 startup manual
- 1 Mini Jumper*10 PCS Package (p/n: 9689000002)

If any of these items are missing or damaged, contact your distributor or sales representative immediately.

Model No. List	Description
PCM-9580F-00A1	W/ 100 BASE-T Ethernet
PCM-9580FG-00A1	W/ 1000 BASE-T Ethernet

Caution! *Possible danger of explosion if batteries (if any) are incorrectly replaced.*



Replace only with the same or equivalent type recommended by the manufacturer.

Achtung! *Dispose of used batteries (if any) according to the manufacturer's instructions.*

Additional Information and Assistance

1. Visit the Advantech web site at **www.advantech.com** where you can find the latest information about the product.
2. Contact your distributor, sales representative, or Advantech's customer service center for technical support if you need additional assistance.

Please have the following information ready before you call:

- Product name and serial number
- Description of your peripheral attachments
- Description of your software (operating system, version, application software, etc.)
- A complete description of the problem
- The exact wording of any error messages

Contents

Chapter 1	Introduction	2
1.1	Introduction	2
1.1.1	Highly integrated multimedia SBC.....	2
1.2	Features	3
1.3	Specifications	3
1.4	Board layout: dimensions.....	6
	Figure 1.1:Board layout: dimensions.....	6
Chapter 2	Installation	8
2.1	Jumpers.....	8
	Table 2.1:Jumpers.....	8
2.1.1	Jumpers setting drawing	8
2.2	Connectors.....	8
	Table 2.2:Connectors.....	8
2.3	Locating jumpers and Connectors.....	10
	Figure 2.1:Jumper & Connector (component side)	10
2.4	Setting Jumpers	11
2.5	Clear CMOS (SW1)	12
2.6	Installing DIMMs.....	12
2.7	IDE, CDROM hard drive connector (CN15, CN13).....	13
2.7.1	Connecting the hard drive.....	13
2.8	Solid State Disk.....	13
2.8.1	CompactFlash (CN19).....	13
2.9	Floppy drive connector (CN12)	14
2.9.1	Connecting the floppy drive	14
2.10	Parallel port connector (CN11)	15
2.11	Keyboard and PS/2 mouse connector (CN17)	15
2.12	Front Panel Connector (CN14)	15
2.12.1	Power & HDD LED (pin 1-4 of CN14).....	15
2.12.2	Reset switch (pin 13-14 of CN14).....	15
2.13	Power connectors (CN6, CN10, FAN1, FAN2).....	16
2.13.1	ATX power connector, +3.3V, +5V, +12V (CN6).....	16
2.13.2	ATX power connector, +12 V (CN10).....	16
2.13.3	System Fan power supply connector (FAN1).....	16
2.13.4	CPU Fan power supply connector (FAN2).....	16
2.14	ATX power ON/OFF switch con. pin 11-12 of CN14....	16
2.14.1	ATX feature (CN6) & soft power switch (CN14)	16
2.15	Audio AC'97 Link interfaces (CN4)	16
2.15.1	PCM-231AV.....	17
2.15.2	CD audio input connector (CN3 on the PCM-231AV)17	

2.16	COM port connector (CN7)	17
2.17	VGA/LVDS interface connections (CN5, CN9).....	17
2.17.1	CRT display connector (CN9).....	17
2.17.2	LVDS LCD panel connector (CN5)	17
2.17.3	Panel type selection (S1).....	18
2.18	TV-out interface (optional) (CN2)	18
2.19	Ethernet configuration (CN25,CN26).....	18
2.19.1	100Base-T connector (CN25, PCM-9580F).....	19
2.19.2	1000Base-T connector (CN26, PCM-9580FG).....	19
2.19.3	Network boot	19
2.20	USB connectors (CN1, CN23).....	19
2.20.1	Embedded USB interface:	20
	Table 2.3:Embedded USB Pin Assignment.....	21
	Figure 2.2:Embedded USB Mod. Type I.....	22
	Figure 2.3:Embedded USB Type II/III Form Factor	23
Chapter 3	Software Configuration	26
3.1	Introduction	26
3.2	Connections to Three Standard LCDs.....	26
3.2.1	LG LM150X06 (1024x768(16 colors) LVDS LCD) ...	26
	Table 3.1:Connections to LG LM150X06.....	26
Chapter 4	Award BIOS Setup.....	30
4.1	System test and initialization.....	30
4.1.1	System configuration verification.....	30
4.2	Award BIOS setup	31
4.2.1	Entering setup	31
	Figure 4.1:BIOS setup program initial screen	31
4.2.2	Standard CMOS Features setup.....	32
	Figure 4.2:CMOS Features setup.....	32
4.2.3	Advanced BIOS Features setup.....	33
	Figure 4.3:Advanced BIOS Features setup.....	33
4.2.4	Advanced Chipset Features setup	34
	Figure 4.4:Advanced Chipset Features setup	34
4.2.5	Integrated Peripherals	34
	Figure 4.5:Integrated Peripherals.....	34
4.2.6	Power Management Setup	35
	Figure 4.6:Power Management Setup.....	35
4.2.7	PnP/PCI Configurations.....	35
	Figure 4.7:PnP/PCI Configurations	35
4.2.8	PC Health Status	36
	Figure 4.8:PC Health Status.....	36
4.2.9	Frequency/Voltage Control.....	37
	Figure 4.9:Frequency/Voltage Control.....	37
4.2.10	Load Optimized Defaults.....	38
4.2.11	Set Password.....	38

	4.2.12	Save & Exit Setup.....	39
	4.2.13	Exit Without Saving.....	39
Chapter	5	PCI SVGA Setup.....	42
	5.1	Introduction.....	42
	5.1.1	Chipset.....	42
	5.1.2	Display memory.....	42
	5.1.3	Display types.....	42
	5.1.4	Dual/Simultaneous Display.....	43
		Figure 5.1:Selecting Display Settings.....	44
	5.2	Installation of the SVGA Driver.....	45
	5.2.1	Installation for Windows 98/ME/2000/XP.....	45
	5.3	Further Information.....	47
Chapter	6	Audio Setup.....	50
	6.1	Introduction.....	50
	6.2	Driver installation.....	50
	6.2.1	Before you begin.....	50
Chapter	7	PCI Bus Ethernet Interface.....	58
	7.1	Introduction.....	58
	7.2	Features.....	58
	7.3	Installation of Ethernet Driver.....	58
	7.3.1	Installation for Windows 2000.....	59
	7.3.2	Installation for Windows NT.....	63
	7.4	Further information.....	69
Appendix A		Programming the GPIO & Waterdog Timer ..	72
	A.1	Supported GPIO Register.....	72
	A.1.1	GPIO Registers.....	72
	A.1.2	GPIO Example program-1.....	73
	A.2	Watchdog programming.....	75
Appendix B		Pin Assignments.....	78
	B.1	System fan power connector (FAN1)	
		CPU fan connector (FAN 2) 78	
		Table B.1:System fan power connector (FAN 1)	
		CPU Fan Power Connector (FAN 2)78	
	B.2	Ethernet 10/100Base-T Connector (CN25).....	79
	B.3	Ethernet 10/100/1000 BASE-T connector (CN26).....	79
	B.4	Ethernet LED connector (CN27).....	80
	B.5	ACLink audio connector (CN4).....	81
	B.6	ATX Main Power Connector (CN6).....	82
	B.7	ATX 12V power connector (CN10).....	82
	B.8	Keyboard and PS/2 Mouse Connector (CN17).....	83

B.9	Floppy Disk Drive Connector (CN12)	84
B.10	IDE Hard Drive Connector (CN15, CN13)	85
B.11	Parallel Port Connector (CN11)	86
B.12	Front Panel (CN14)	87
B.13	USB Connector (CN1)	88
B.14	Embedded USB Connector (CN23)	88
B.15	LCD Inverter Backlight Connector (CN3)	89
B.16	CRT Display Connector (CN9)	89
	Table B.16:CRT Display Connector (CN9)	89
B.17	TV (video) Out Connector (CN2)	90
B.18	LVDS Connector (CN5)	91
B.19	COM Port Connector (CN7)	92
B.20	CompactFlash Card Connector (CN19)	93
	Table B.19:CompactFlash Card Connector (CN19)	93
B.21	GPIO Connector (CN16)	94
Appendix C	System Assignments	96
C.1	System I/O Ports	96
	Table C.1:System I/O Ports	96
C.2	1st MB memory map	97
	Table C.2:1st MB memory map	97
C.3	DMA channel assignments	97
	Table C.3:DMA channel assignments	97
C.4	Interrupt assignments	98
	Table C.4:Interrupt assignments	98
Appendix D	Optional Extras	100
D.1	PCM-10586-6000 Cable kit for PCM-9580F	100
	Table D.1:PCM-10586-6000 wiring kit for PCM-9580F.	100
D.2	PCM-10586-6G00 Cable kit for PCM-9580FG	101
D.3	Optional USB cable (CN1 or CN23)	102
D.4	ATX Power Control Cable (CN10)	102
Appendix E	Mechanical Drawings	104

General Information

This chapter gives background information on the PCM-9580.

Sections include:

- Introduction
- Features
- Specifications
- Board layout and dimensions

Chapter 1 Introduction

1.1 Introduction

The PCM-9580 is a Socket 478 Pentium IV single board computer (SBC) with Gigabit, USB 2.0, 2channel 48-bit LVDS, audio controller, a 4X AGP SVGA controller, one PCI slot and TV-out function. It supports Pentium IV up to 3.06 GHz (at 25°C). The PCM-9580's design is based on the 5.25" form factor that provides support for PCI module expansion. The 5.25" form factor also provides a convenient connector layout for easy assembly, more efficient cable connections and better overall embedded system integration. This compact (only 5.75" x 8") unit offers all the functions of a single board industrial computer, but still fits in the space of a 5.25" CD-ROM drive.

On-board features include, four serial ports, one multi-mode parallel (ECP/EPP/SPP) port, 4 USB (Universal Serial Bus) 1.1/2.0 ports, an optional floppy drive controller, and a keyboard/PS/2 mouse interface. The built-in high-speed PCI IDE controller supports both PIO and UDMA/100 bus master modes. Up to four IDE devices can be connected, including large hard disks, CD-ROM drives, and tape backup drives.

The PCM-9580 features power management to minimize power consumption. It complies with the "Green Function" standard and supports Doze, Standby and Suspend modes. In addition, the board's watchdog timer can automatically reset the system or generate an interrupt if the system stops due to a program bug or EMI.

1.1.1 Highly integrated multimedia SBC

The PCM-9580 is a highly integrated multimedia SBC that combines audio, video, and network functions on a single computer board the size of a 5.25" CD-ROM drive. It provides an AC-97 interface and supports Line-in, Line-out, and MIC-in via Optional PCM-232 audio module, and up to 1600 x 1200 resolution @ 16.8 M colors with 8 to 64MB frame buffer with system memory. Major on-board devices adopt PCI technology, to achieve outstanding computing performance when used with Intel® Pentium®IV processors. The PCM-9580 also supports an TV-out for NTSC/PAL multimedia applications.

1.2 Features

- Socket 478 up to 3.06 Ghz Intel Pentium 4
- Supports Gigabit Ethernet (PCM-9580FG)
- Supports Embedded USB, 4 USB 2.0 ports
- Supports 2-channel 48-bit LVDS interface
- Optional Audio Module

1.3 Specifications

Standard SBC Functions

- **CPU:** Socket 478 for Intel Celeron/Pentium 4 up to 2.4 GHz
- **BIOS:** Award 512 KB Flash memory
- **System memory:** Two 184 pin DIMM sockets, support Non-ECC Double Data Rate (DDR)128 MB to 2 GB, accepts 128/256/512/1000 MB DDR200/266 DRAM.
- **2nd cache memory:** 128/256/512 KB on the Celeron/ Pentium4 processor
- **Enhanced IDE interface:** Two channels supports up to four EIDE devices. BIOS auto-detect, PIO Mode 3 or Mode 4, UDMA 33 transfer. Primary IDE support up to UDMA 66/100 mode
- **FDD interface:** Supports up to two FDDs
- **Serial ports:** Four serial RS-232 ports
- **Parallel port:** One parallel port, supports SPP/EPP/ECP mode
- **Keyboard/mouse connector:** Supports standard PS/2 keyboard and a PS/2 mouse
- **Power management:** Supports power saving modes including Normal/ Standby/Suspend modes. APM 1.2 compliant
- **Watchdog timer:** 255 level timer intervals by Second or Minute
- **USB:** Four USB 1.1/2.0 compliant host ports
- **Expansion:** One PCI slot for PCI control board

Solid State Disk

- Supports one 50-pin socket for CFC type I/II

VGA/LCD Interface

- **Chipset:** Intel 845GV +Chrontel CH7017
- **Frame buffer:** Supports 8 MB to 64 MB frame buffer with system memory
- **Interface:** 4x AGP VGA/LVDS interface
- **Display mode:** CRT Modes: 1280 x 1024@16bpp (60Hz), 1024 x 768@16bpp, , 1600 x 1200@32bpp (85Hz)
- **LVDS:** Supports 2 Channel (2 x 24 bit) LVDS interface

TV-out

- **Chipset:** Chrontel CH7017
- Supports NTSC and PAL TV formats
- Provides S-video outputs via optional TV-out cable (1703050306)
- Supports 640 x 480 and 800 x 600 input resolutions
- Supports Windows® 9x/ME/2000/NT and Windows XP drivers
- Over-scan, under-scan and position adjustable

Ethernet interface

- **Chipset:**
- Intel 82551ER [Intel 82551QM optional] (PCM-9580F)
- Intel 82540EM (PCM-9580FG)
- Ethernet interface:
- IEEE 802.3u 100BASE-T Fast Ethernet compatible(PCM-9580F)
- IEEE 802.3z/ab 1000 BASE-T Gigabit Ethernet compatible (PCM-9580FG)
- I/O address switchless setting
- Built-in boot ROM

Audio Function (optional)

- **Chipset:** Intel 82801DB (ICH4)
- **Audio controller:** AC'97 ver. 2.0 compliant interface
- Optional PCM-231A support Line-in, Line-out, MIC

Mechanical and Environmental

- **Dimensions:** (L x W)203 x 146 mm (8" x 5.75")
- **Power supply Voltage:**+5 V \pm 5%, +12 V \pm 5%, +3.3 V \pm 5%

- Max : 0.5A @ +5 V, 5.2A @ +12 V ,3.4A @3.3 V
- (within 5 ms after power on)
- Typical: 0.5A @ +5 V, 4.4A @ +12 V, 2.7A @ +3.3 V
- (with 256 MB DRAM, Pentium 4, 3.06GHz @ 25 ° C)
- **Operating temperature:**0 ~ 60° C (32~140° F) with up to 2.4 GHz Pentium 4 CPU
- **Operating Humidity:**0% ~ 90% Relative Humidity, noncondensing
- **Weight:** 0.85 kg (weight of total package)

Installation

This chapter explains the setup procedures of PCM-9580 hardware, including instructions on setting jumpers and connecting peripherals, switches and indicators. Be sure to read all safety precautions before you begin the installation procedure.

Chapter 2 Installation

2.1 Jumpers

The PCM-9580 has a number of jumpers that allow you to configure your system to suit your application. The table below lists the functions of the various jumpers.

Table 2.1: Jumpers

Label	Function
JP1	LCD power select

2.1.1 Jumpers setting drawing

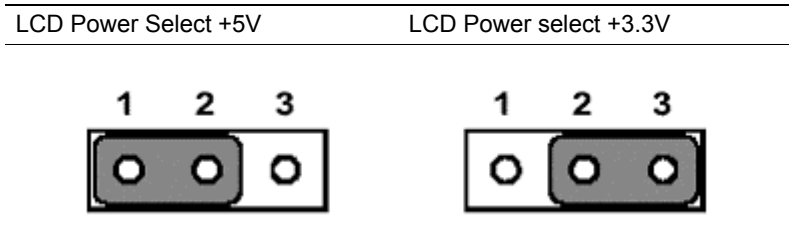

2.2 Connectors

On-board connectors link the PCM-9580 to external devices such as hard disk drives, a keyboard, or floppy drives. The table below lists the function of each of the board's connectors.

Table 2.2: Connectors

Label	Function
CN1	USB1,2 connector
CN2	TV-out connector (optional)
CN3	Backlight control connector
CN4	AC97 (Audio) connector

Table 2.2: Connectors

CN5	LVDS connector
CN6	ATX power connector
CN7	4COM port connector
CN9	CRT display connector
CN10	ATX 12 V power connector
CN11	Parallel port connector
CN12	Floppy drive connector
CN13	IDE hard drive connector (secondary)
CN14	Front Panel
CN15	IDE hard drive connector (primary)
CN16	4 bit GPIO connector
CN17	Keyboard and PS/2 mouse connector
CN19	CFC connector
CN23	Embedded USB
CN25	10/100Base-T Ethernet connector (PCM-9580F)
CN26	Gigabit Ethernet connector(PCM-9580FG)
CN27	Gigabit LAN LED connector
Fan2	CPU fan connector
SW1	Clear CMOS
Fan1	System fan power connector

2.3 Locating jumpers and Connectors

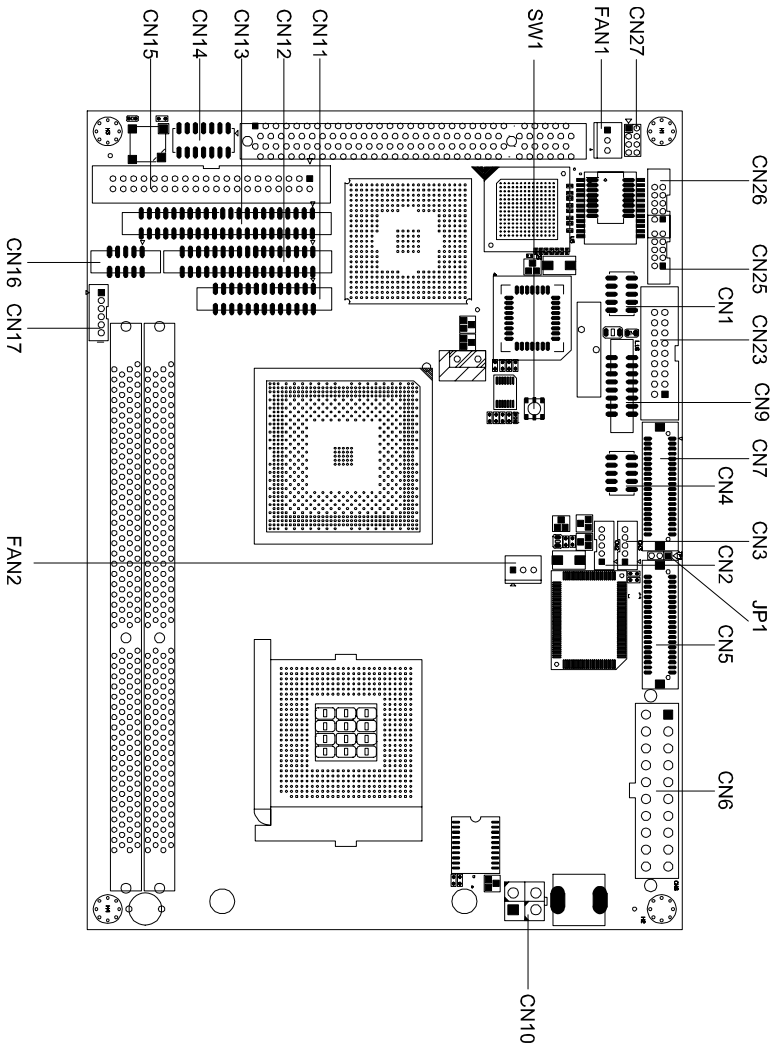
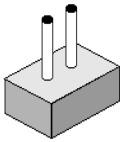

Figure 2.1: Jumper & Connector (component side)

2.4 Setting Jumpers

You may configure your card to match the needs of your application by setting jumpers. A jumper is a metal bridge used to close an electric circuit. It consists of two metal pins and a small metal clip (often protected by a plastic cover) that slides over the pins to connect them. To “close” a jumper, you connect the pins with the clip. To “open” a jumper, you remove the clip. Sometimes a jumper will have three pins, labeled 1, 2 and 3. In this case you would connect either pins 1 and 2, or 2 and 3.



open

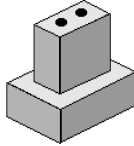

closed

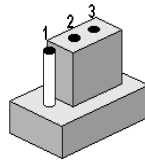

closed 2-3

The jumper settings are schematically depicted in this manual as follows:

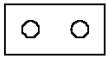

open



closed

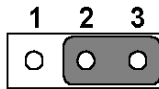

closed 2-3

A pair of needle-nose pliers may be helpful when working with jumpers.

If you have any doubts about the best hardware configuration for your application, contact your local distributor or sales representative before you make any changes.

Generally, you simply need a standard cable to make most connections.

2.5 Clear CMOS (SW1)

Warning! To avoid damaging the computer, always turn off the power supply before setting “Clear CMOS.” Before turning on the power supply, set the jumper back to “3.0 V Battery On.”

This jumper is used to erase CMOS data and reset system BIOS information.

The procedure for clearing CMOS is:

1. Turn off the system.
2. Push SW1
3. Turn on the system. The BIOS is now reset to its default setting

2.6 Installing DIMMs

The procedure for installing DIMMs is described below. Please follow these steps carefully. The number of pins are different on either side of the breaks, so the module can only fit in one way. DIMM modules have different pin contacts on each side, and therefore have a higher pin density.

1. Make sure that the two handles of the DIMM socket are in the “open” position. i.e. The handles remain leaning outward.
2. Slowly slide the DIMM module along the plastic guides on both ends of the socket.
3. Press the DIMM module right down into the socket, until you hear a click. This is when the two handles have automatically locked the memory module into the correct position of the socket.

To **remove** the memory module, just push both handles outward, and the module will be ejected from the socket.

2.7 IDE, CDROM hard drive connector (CN15, CN13)

The PCM-9580 provides 2 IDE channels which you can attach up to four Enhanced Integrated Device Electronics hard disk drives or CDROM to the PCM-9580's internal controller. The PCM-9580's IDE controller uses a PCI interface. This advanced IDE controller supports faster data transfer, PIO mode 3, mode 4 and UDMA/100. The secondary channel supports UDMA/33 only.

2.7.1 Connecting the hard drive

Connecting drives is done in a daisy-chain fashion. It requires one of two cables (not included in this package), depending on the drive size. 1.8" and 2.5" drives need a 1 x 44-pin to 2 x 44-pin flat-cable connector. 3.5" drives use a 1 x 44-pin to 2 x 40-pin connector.

Wire number 1 on the cable is red or blue, and the other wires are gray.

1. Connect one end of the cable to CN15 or CN13. Make sure that the red (or blue) wire corresponds to pin 1 on the connector, which is labeled on the board (on the right side).
2. Plug the other end of the cable into the Enhanced IDE hard drive, with pin 1 on the cable corresponding to pin 1 on the hard drive. (See your hard drive's documentation for the location of the connector.)

If desired, connect a second drive as described above.

Unlike floppy drives, IDE hard drives can connect to either end of the cable. If you install two drives, you will need to set one as the master and one as the slave by using jumpers on the drives. If you install only one drive, set it as the master.

2.8 Solid State Disk

The PCM-9580 provides a CompactFlash™ card socket and DiskOnChip socket for Solid state disk solutions.

2.8.1 CompactFlash (CN19)

The CompactFlash card shares a secondary IDE channel which can be enabled/disabled via the BIOS settings.

2.9 Floppy drive connector (CN12)

You can attach up to two floppy drives to the PCM-9580's on-board controller. You can use any combination of 5.25" (360 KB and 1.2 MB) and/or 3.5" (720 KB, 1.44 MB, and 2.88 MB) drives.

A 34-pin daisy-chain drive connector cable is required for a dual-drive system. On one end of the cable is a 34-pin flat-cable connector. On the other end are two sets of floppy disk drive connectors. Each set consists of a 34-pin flat-cable connector (usually used for 3.5" drives) and a printed-circuit board connector (usually used for 5.25" drives).

2.9.1 Connecting the floppy drive

1. Plug the 34-pin flat-cable connector into CN12. Make sure that the red wire corresponds to pin one on the connector.
2. Attach the appropriate connector on the other end of the cable to the floppy drive(s). You can use only one connector in the set. The set on the end (after the twist in the cable) connects to the A: drive. The set in the middle connects to the B: drive.
3. If you are connecting a 5.25" floppy drive, line up the slot in the printed circuit board with the blocked-off part of the cable connector.

If you are connecting a 3.5" floppy drive, you may have trouble determining which pin is number one. Look for a number printed on the circuit board indicating pin number one. In addition, the connector on the floppy drive may have a slot. When the slot is up, pin number one should be on the right. Check the documentation that came with the drive for more information.

If you desire, connect the B: drive to the connectors in the middle of the cable as described above.

In case you need to make your own cable, you can find the pin assignments for the board's connector in Appendix C.

2.10 Parallel port connector (CN11)

Normally, the parallel port is used to connect the card to a printer. The PCM-9580 includes a multi-mode (ECP/EPP/SPP) parallel port accessed via CN11 and a 26-pin flat-cable connector. You will need an adapter cable if you use a traditional DB-25 connector. The adapter cable has a 26-pin connector on one end, and a DB-25 connector on the other.

The parallel port is designated as LPT1, and can be disabled or changed to LPT2 or LPT3 in the system BIOS setup.

The parallel port interrupt channel is designated to be IRQ7.

You can select ECP/EPP/SPP DMA channel via BIOS setup.

2.11 Keyboard and PS/2 mouse connector (CN17)

The PCM-9580 board provides a keyboard connector that supports both a keyboard and a PS/2 style mouse. In most cases, especially in embedded applications, a keyboard is not used. If the keyboard is not present, the standard PC/AT BIOS will report an error or fail during power-on self-test (POST) after a reset. The PCM-9580's BIOS standard setup menu allows you to select "All, But Keyboard" under the "Halt On" selection. This allows no-keyboard operation in embedded system applications, without the system halting under POST.

2.12 Front Panel Connector (CN14)

Next, you may want to install external switches to monitor and control the PCM-9580. These features are optional: install them only if you need them. The Front Panel connector (CN14) is a 14-pin male, dual in-line header. It provides connections for a hard disk access indicator, LAN Act., LAN Link, hardware reset, ATX power ON/OFF switch connector, and power on indicator.

2.12.1 Power & HDD LED (pin 1-4 of CN14)

The HDD LED indicator for hard disk access is an active low signal (24 mA sink rate). Power supply activity LED indicator.

2.12.2 Reset switch (pin 13-14 of CN14)

If you install a reset switch, it should be an open single pole switch. Momentarily pressing the switch will activate a reset. The switch should be rated for 10 mA, 5 V.

2.13 Power connectors (CN6, CN10, FAN1, FAN2)

2.13.1 ATX power connector, +3.3V, +5V, +12V (CN6)

Supplies main power to the PCM-9580 (+12V, +5V, +3.3V) and to devices that require.

2.13.2 ATX power connector, +12 V (CN10)

Supplies ATX +12V power to the PCM-9580s Vcore of the CPU

2.13.3 System Fan power supply connector (FAN1)

Provides power supply to system fan. Only present when +12V power is supplied to the board.

2.13.4 CPU Fan power supply connector (FAN2)

Provides power supply +12V to CPU cooling fan, and fan speed detects signal input.

2.14 ATX power ON/OFF switch con. pin 11-12 of CN14

2.14.1 ATX feature (CN6) & soft power switch (CN14)

The PCM-9580 can support an advanced soft power switch function, if an ATX power supply is used. To enable the soft power switch function connect the power on/off button to CN14. (A momentary type of button should be used.)

Important *Make sure that the ATX power supply can take at least a 10 mA load on the 5 V standby lead (5VSB). If not, you may have difficulty powering on your system.*

2.15 Audio AC'97 Link interfaces (CN4)

This connector (CN4) provide AC'97 Link signal to connect to PCM-231AV, which provides 16-bit CD quality recording and playback as well as OPL3 compatible FM music. It is supported by all major operating systems and is completely compatible with Sound Blaster Pro. The PCM-9580 also supports full audio function via an optional AC'97 link module PCM-231AV which also provides TV-out function.

2.15.1 PCM-231AV

The PCM-231AV provides CD audio input connector, microphone in (mono), line in (stereo) and line out (stereo), standard connector and S-video, composite-video connector for TV-out function on the PCM-231AV.

2.15.2 CD audio input connector (CN3 on the PCM-231AV)

All CD-ROM drives can provide analog audio signal output when used as a music CD player. The CN3 is a connector to input CD audio signals into the audio controller. The audio cable of your CD-ROM drive is suitable for connection to CN3 of PCM-231AV

Configuration of the audio interface is done completely via software utilities. You don't have to set any jumpers. For further information, please refer to Chapter 6 for audio setup details.

2.16 COM port connector (CN7)

The PCM-9580 provides four RS-232 serial ports in one COM port connector. The COM port connector is a 40-pin, DF13A-40DP-1.25V (Hirose Electric Co., Ltd). It provides connections for serial devices (a mouse, etc.) or a communication network. You can find the pin assignments for the COM port connector in Appendix C.

2.17 VGA/LVDS interface connections (CN5, CN9)

The PCM-9580's AGP SVGA interface can drive conventional CRT displays and is capable of driving a wide range of LVDS flat panel displays. The board has three connectors to support these displays: one for standard CRT VGA monitors and one for LVDS type LCD panels.

2.17.1 CRT display connector (CN9)

CN9 is a 16-pin, dual-inline header used for conventional CRT displays. A simple one-to-one adapter can be used to match CN9 to a standard 15-pin D-SUB connector commonly used for VGA.

Pin assignments for CRT display connector CN9 are detailed in Appendix C.

2.17.2 LVDS LCD panel connector (CN5)

The PCM-9580 uses the Intel 845GV that supports 2 channel (2 x 24 bit) LVDS LCD panel displays. Users can connect to either an 24 or 48 bit LVDS LCD with CN5.

2.17.3 Panel type selection (S1)

S1 is an 8 segment DIP switch for DSTN/TFT panel type and resolution functions.

Table 2.3: S1 Panel Type select

Panel Type	Resolution
LVDS**	640 x 480
LVDS**	800 x 600
LVDS*	1024 x 768
LVDS	1280 x 1024
LVDS**	1600 x 1200
LVDS**	2048 x 1536

* Default Setting

** will support in the future

2.18 TV-out interface (optional) (CN2)

The PCM-9580 board provides optional TV-out via CN2. This consists of a 5-pin wafer box header. Output supports composite video and S-video connectors via an optional cable kit (p/n: 1103050306). TV-out generators use both NTSC and PAL formats.

To set up your video interface run the appropriate installation program located on the utility disk. That's all there is to it.

2.19 Ethernet configuration (CN25,CN26)

The PCM-9580 is equipped with a high performance 32-bit PCI-bus Ethernet interface which is fully compliant with IEEE 802.3U 10/100Mbps CSMA/CD standards. It is supported by all major network operating systems.

The medium type can be configured via the RSET8139.EXE program included on the utility disk. (See Chapter 3 for detailed information.)

2.19.1 100Base-T connector (CN25, PCM-9580F)

10/100Base-T connects to the PCM-9580F via an adapter cable to a 10-pin polarized header (CN25).

2.19.2 1000Base-T connector (CN26, PCM-9580FG)

10/100/1000 Base-T connects to the PCM-9580FG via an adapter cable to a 10-pin polarized header (CN26).

2.19.3 Network boot

The Network Boot feature can be utilized by incorporating the Boot ROM image files for the appropriate network operating system. The Boot ROM BIOS files are included in the system BIOS, which is on the utility CD disc.

2.20 USB connectors (CN1, CN23)

The PCM-9580 board provides up to four USB (Universal Serial Bus) 1.1/2.0 ports. This gives complete Plug and Play, and hot attach/detach for up to 127 external devices. The USB interfaces comply with USB specification Rev. 1.1, and are fuse protected.

The PCM-9580FG Support Embedded USB interface which used one 9 x 2-pin header connector for USB 3, 4 (CN23) and one 5 x 2 pin header connector for USB 1, 2 (CN1). You will need an USB cable if you use a standard USB connector in CN1 or CN23 (embedded USB). The adapter cable has a 5 x 2-pin connector on one end and a USB connector on the other. The Optional USB Cable for CN1 P/N is 1703100260. For Embedded USB CN23 P/N is 1700180170. The USB interfaces can be disabled in the system BIOS setup.

2.20.1 Embedded USB interface:

Overview

The Embedded USB interface Specification defines an alternate implementation for small form factor USB Module referred to in this specification as a Embedded USB Module

This specification uses a qualified sub-set of the same signal protocol, electrical definitions, and configuration definitions as the USB 2.0 Specification.

The primary differences between a standard USB 2.0 and a Embedded USB Interface are:

- Support more one Vcc +5V signal in the Embedded USB Interface
- Support Vcc 3.3V and OVER CURRENT signal in the Embedded USB Interface

2.21.1.1 Features and Benefits

- Upgrade ability
Embedded USB Module are removable and upgradeable with available “new technology” cards.
- Flexibility
A single Mini PCI interface can accommodate various types of communications, Flash memory storage, and Industry control I/O devices.
- Serviceability
Mini PCI Cards can be removed and easily serviced if they fail.
- Reliability
Mini PCI Cards will be mass produced and, consequently, of higher quality than low-volume custom boards.
- Reduced Size
Embedded USB Module are smaller than PCMCIA cards, Small PCI cards
- High Performance
The USB 2.0 high-performance characteristics which Transfer rate up to 480Mbps

2.21.1.2 Embedded USB Connector dimension and Pin assignment

Embedded USB on board connector is used pitch 2 x 9 Pin header with 2.54mm pin

Table 2.3: Embedded USB Pin Assignment

Pin	Signal	Pin	Signal
1	GND	2	GND
3	GND (USB)	4	GND (USB)
5	Vcc (USB)	6	Vcc (USB)
7	Data 1-	8	Data 2-
9	Data 1+	10	Data 2+
11	GND (USB)	12	GND (USB)
13	Key	14	N/C
15	Vcc5V	16	VCC3
17	GND	18	GND

2.21.1.3. Mechanical Specification

I. Overview

The specification defines three form factors: Type I, Type II and Type III are dual 18-pin connector interfaces; The all of type connector are used PC standard 2.54mm pin pitch pin header

II. Type I Form Factor

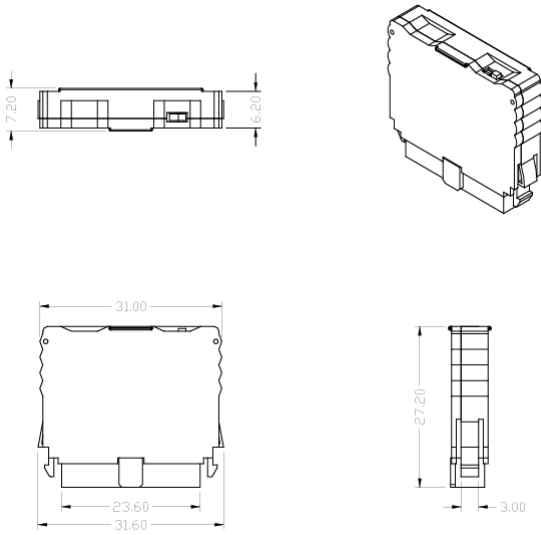

Figure 2.2: Embedded USB Mod. Type I

Note:

1. Type I will support Flash memory module only
2. Type I is a vertical assembly with mainboard (SBC)

III. Type II/III Form Factor

Figure 2.3: Embedded USB Type II/III Form Factor

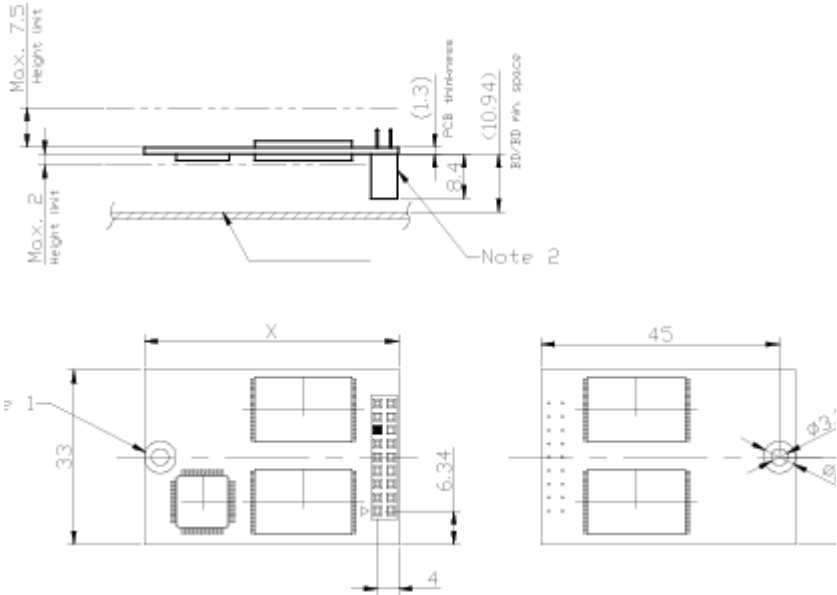

Notes:

1. Unit is metric.
2. $\phi 6$ area preserved for Screw cap(Bothe side), No trace.
3. Pin Header 2 Row x 9 positions (Female, Pitch 2.54 mm SQ)
4. Type 2 X=50.8mm, type 3 X=76.2mm
5. Pin 13th is no definition for circuit design.

- Notes:**
1. Type II/III will support Flash memory Module, Blue-Tooth Module, Wireless LAN Module, and Industrial I/O control module
 2. Type II/III is Board to Board horizontal assembly with Mainboard (SBC)

Software Configuration

This chapter details the software configuration information. It shows you how to configure the card to match your application requirements. The AWARD System BIOS is covered in Chapter 4.

Sections include:

- Introduction
- Connections for standard LCDs
- Ethernet interface configuration.

Chapter 3 Software Configuration

3.1 Introduction

The PCM-9580 system BIOS and custom drivers are located in a 256 Kbyte, Flash ROM device, designated U6. A single Flash chip holds the system BIOS, VGA BIOS and network Boot ROM image. The display can be configured via CMOS settings. This method minimizes the number of chips and difficulty of configuration. To set different types of LCD panels, please choose “panel type” from the “integrated peripherals” menu in CMOS setup.

3.2 Connections to Three Standard LCDs

The following tables illustrate typical LCD connection pinouts for the PCM-9580.

3.2.1 LG LM150X06 (1024x768(16 colors) LVDS LCD)

Table 3.1: Connections to LG LM150X06

LM150X06		PCM-9580 CN23	
Pin	Signal	Pin	Signal
1	Vcc	1	LCD POWER
2	Vcc	2	LCD POWER
3	GND	3	GND
4	GND	4	GND
5	Rx0-	7	LVDSN0
6	Rx0+	9	LVDSP0
7	GND	11	GND
8	Rx1-	13	LVDSN1
9	Rx1+	15	LVDSP1
10	GND	17	GND
11	Rx2-	19	LVDSN2
12	Rx2+	21	LVDSP2
13	GND	23	GND
14	RxC-	25	CKN1
15	RxC+	27	CKP1

Table 3.1: Connections to LG LM150X06

LM150X06		PCM-9580 CN23	
16	GND	29	GND
17	Rx3-	35	LVDSN3
18	Rx3+	37	LVDSP3
19	GND	33	GND
20	NC		

CHAPTER 4

Award BIOS Setup

This chapter describes how to set BIOS configuration data.

Chapter 4 Award BIOS Setup

4.1 System test and initialization

These routines test and initialize board hardware. If the routines encounter an error during the tests, you will either hear a few short beeps or see an error message on the screen. There are two kinds of errors: fatal and non-fatal. The system can usually continue the boot up sequence with non-fatal errors. Non-fatal error messages usually appear on the screen along with the following instructions:

press <F1> to RESUME

Write down the message and press the F1 key to continue the bootup sequence.

4.1.1 System configuration verification

These routines check the current system configuration against the values stored in the board's CMOS memory. If they do not match, the program outputs an error message. You will then need to run the BIOS setup program to set the configuration information in memory.

There are three situations in which you will need to change the CMOS settings:

1. You are starting your system for the first time
2. You have changed the hardware attached to your system
3. The CMOS memory has lost power and the configuration information has been erased.

The PCM-9580 Series' CMOS memory has an integral lithium battery backup. The battery backup should last ten years in normal service, but when it finally runs down, you will need to replace the complete unit.

4.2 Award BIOS setup

Award's BIOS ROM has a built-in Setup program that allows users to modify the basic system configuration. This type of information is stored in battery-backed CMOS RAM so that it retains the Setup information when the power is turned off.

4.2.1 Entering setup

Power on the computer and press immediately. This will allow you to enter Setup.

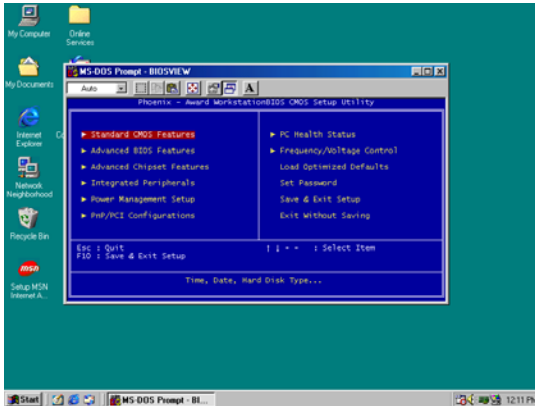

Figure 4.1: BIOS setup program initial screen

4.2.2 Standard CMOS Features setup

When you choose the Standard CMOS Features option from the Initial Setup Screen menu, the screen shown below is displayed. This standard Setup Menu allows users to configure system components such as date, time, hard disk drive, floppy drive and display. Once a field is highlighted, on-line help information is displayed in the left bottom of the Menu screen.

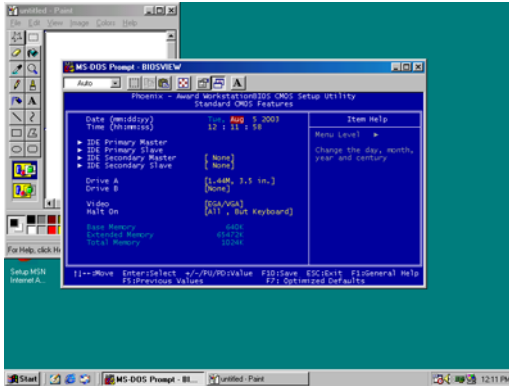

Figure 4.2: CMOS Features setup

4.2.3 Advanced BIOS Features setup

By choosing the Advanced BIOS Features Setup option from the Initial Setup Screen menu, the screen below is displayed. This sample screen contains the manufacturer's default values for the PCM-9580 Series.



Figure 4.3: Advanced BIOS Features setup

4.2.4 Advanced Chipset Features setup

By choosing the Advanced Chipset Features option from the Initial Setup Screen menu, the screen below is displayed. This sample screen contains the manufacturer's default values for the PCM-9580 Series.

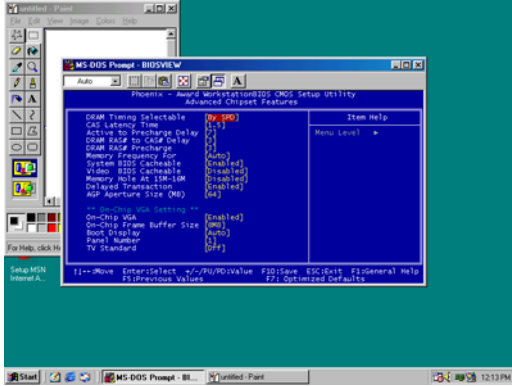

Figure 4.4: Advanced Chipset Features setup

4.2.5 Integrated Peripherals

Choosing the Integrated Peripherals option from the Initial Setup Screen menu should produce the screen below. Here we see the manufacturer's default values for the PCM-9580 Series.

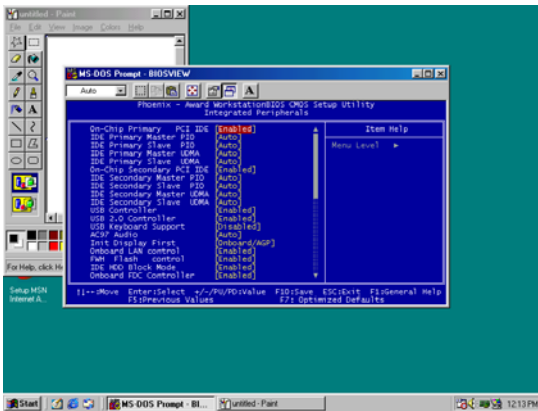

Figure 4.5: Integrated Peripherals

4.2.6 Power Management Setup

By choosing the Power Management Setup option from the Initial Setup Screen menu, the screen below is displayed. This sample screen contains the manufacturer's default values for the PCM-9580 Series.

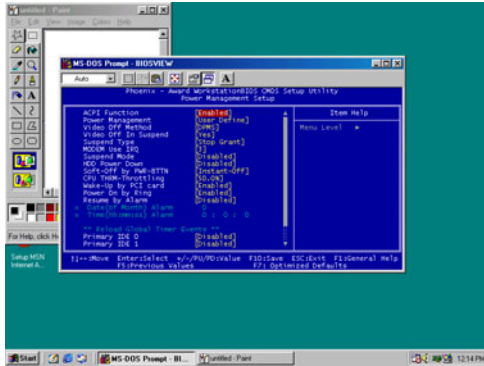

Figure 4.6: Power Management Setup

4.2.7 PnP/PCI Configurations

By choosing the PnP/PCI Configurations option from the Initial Setup Screen menu, the screen below is displayed. This sample screen contains the manufacturer's default values for the PCM-9580 Series.

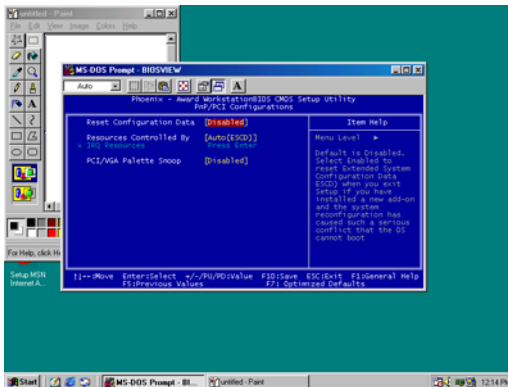

Figure 4.7: PnP/PCI Configurations

4.2.8 PC Health Status

The PC Health Status option displays information such as CPU and motherboard temperatures, fan speeds, and core voltage.

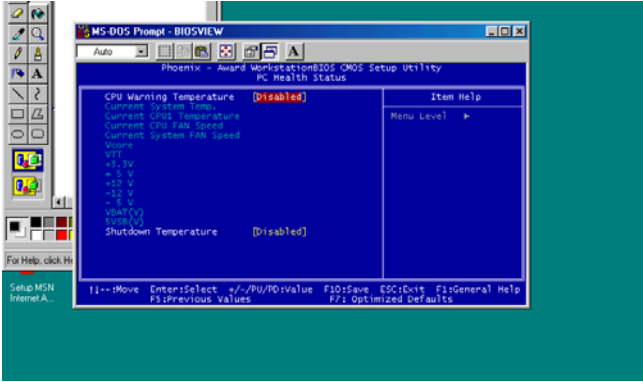

Figure 4.8: PC Health Status

4.2.9 Frequency/Voltage Control

By choosing the Frequency/Voltage Control option from the Initial Setup Screen menu, the screen below is displayed. This sample screen contains the manufacturer's default values for the PCM-9580

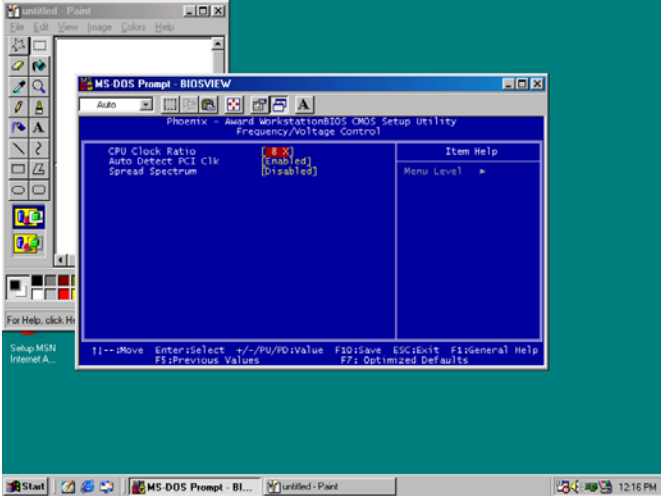

Figure 4.9: Frequency/Voltage Control

Caution *Incorrect settings in Frequency/Voltage Control may damage the system CPU, video adapter, or other hardware.*

4.2.10 Load Optimized Defaults

Load Optimized Defaults loads the default system values directly from ROM. If the stored record created by the Setup program should ever become corrupted (and therefore unusable), these defaults will load automatically when you turn the PCM-9580 Series system on.

4.2.11 Set Password

Note *To enable this feature, you should first go to the Advanced BIOS Features menu, choose the Security Option, and select either Setup or System, depending on which aspect you want password protected. Setup requires a password only to enter Setup. System requires the password either to enter Setup or to boot the system.*

A password may be at most 8 characters long.

To Establish Password

1. Choose the Set Password option from the CMOS Setup Utility main menu and press <Enter>.
2. When you see “Enter Password,” enter the desired password and press <Enter>.
3. At the “Confirm Password” prompt, retype the desired password, then press <Enter>.
4. Select Save to CMOS and EXIT, type <Y>, then <Enter>.

To Change Password

1. Choose the Set Password option from the CMOS Setup Utility main menu and press <Enter>.
2. When you see “Enter Password,” enter the existing password and press <Enter>.
3. You will see “Confirm Password.” Type it again, and press <Enter>.
4. Select Set Password again, and at the “Enter Password” prompt, enter the new password and press <Enter>.

5. At the “Confirm Password” prompt, retype the new password, and press <Enter>.
6. Select Save to CMOS and EXIT, type <Y>, then <Enter>.

To Disable Password

1. Choose the Set Password option from the CMOS Setup Utility main menu and press <Enter>.
2. When you see “Enter Password,” enter the existing password and press <Enter>.
3. You will see “Confirm Password.” Type it again, and press <Enter>.
4. Select Set Password again, and at the “Enter Password” prompt, don’t enter anything; just press <Enter>.
5. At the “Confirm Password” prompt, again don’t type in anything; just press <Enter>.
6. Select Save to CMOS and EXIT, type <Y>, then <Enter>.

4.2.12 Save & Exit Setup

If you select this option and press <Y> then <Enter>, the values entered in the setup utilities will be recorded in the chipset’s CMOS memory. The microprocessor will check this every time you turn your system on and use the settings to configure the system. This record is required for the system to operate.

4.2.13 Exit Without Saving

Selecting this option and pressing <Enter> lets you exit the Setup program without recording any new values or changing old ones.

PCI SVGA Setup

Introduction

Installation of SVGA drivers

-for Windows 98/2000/XP

-for Windows NT

Further information

Chapter 5 PCI SVGA Setup

5.1 Introduction

The PCM-9580 has an onboard AGP flat panel/VGA interface. The specifications and features are described as follows:

5.1.1 Chipset

The PCM-9580 uses a Intel 845GV + Chronitel 7017 chipset. for its AGP/SVGA controller. It supports LVDS LCD displays and conventional analog CRT monitors. In addition, it also supports interlaced and non-interlaced analog monitors (color and monochrome VGA) in high-resolution modes while maintaining complete IBM VGA compatibility. Digital monitors (i.e. MDA, CGA, and EGA) are NOT supported. Multiple frequency (multisync) monitors are handled as if they were analog monitors.

5.1.2 Display memory

The 845GV chip can support up to 64MB dynamic frame buffer shared with system memory; the VGA controller can drive CRT displays or color panel displays with resolutions up to 1280 x 1024@16bpp (60Hz), 1024 x 768@16bpp, , 1600 x 1200@32bpp (85Hz) in CRT Modes, 1600x1200 panels at 60Hz refresh rate IN LVDS Mode.

5.1.3 Display types

CRT and panel displays can be used simultaneously. The PCM-9580 can be set in one of three configurations: on a CRT, on a flat panel display, or on both simultaneously. The system is initially set to simultaneous display mode. If you want to enable the CRT display only or the flat panel display only. Please set up manually. Set up example is shown as in the following chapters.

5.1.4 Dual/Simultaneous Display

The PCM-9580 uses a Intel 845GV + Chronitel 7017 controller that is capable of providing simultaneous dual view display of the same content on a flat panel and CRT.

To set up dual view (simultaneous mode) under Windows 9x, Windows ME, Windows NT/2000/XP, follow these steps:

Step 1. Open the Control panel, and select "Display", "Settings".

Step 2. Select "Advanced.."

Step 3. Select "Graphic Properties.."

Step 4. Select "Devices" mode and click "OK".

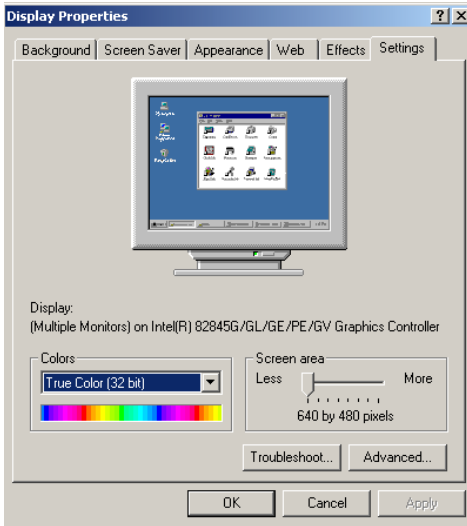

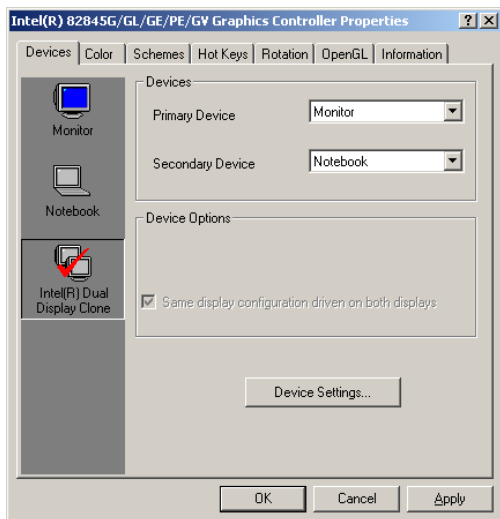
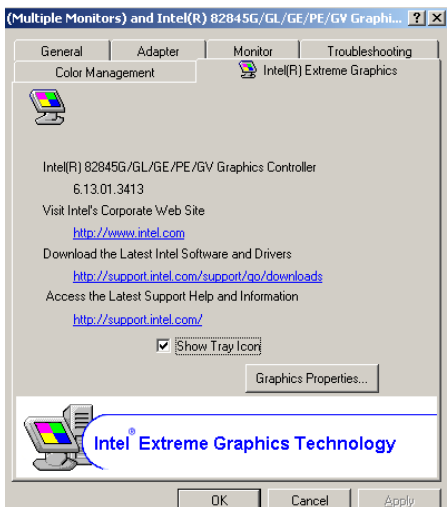

Figure 5.1: Selecting Display Settings

5.2 Installation of the SVGA Driver

Complete the following steps to install the SVGA driver. Follow the procedures in the flow chart that apply to the operating system that you are using within your PCM-9580.

- Notes:**
1. The windows illustrations in this chapter are intended as examples only. Please follow the listed steps, and pay attention to the instructions which appear on your screen.
 2. For convenience, the CD-ROM drive is designated as "D" throughout this chapter.

5.2.1 Installation for Windows 98/ME/2000/XP

To install SVGA driver for Windows 98/2000/XP, please run the set up wizard "Intel(R) Chipset Graphic Driver Software - Installshield Wizard" in CD-ROM. Example of installation steps is shown as bellow:

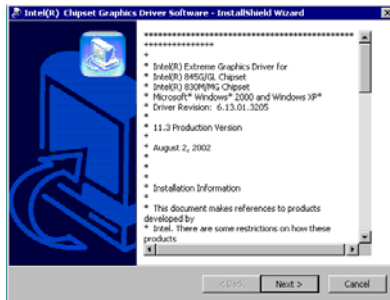



Press “Yes” to reboot.

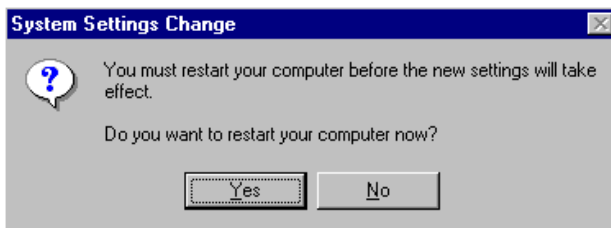

5.3 Further Information

For further information about the AGP/VGA installation in your PCM-9580, including driver updates, troubleshooting guides and FAQ lists, visit the following web resources:

Advantech websites: www.advantech.com
www.advantech.com.tw

Audio Setup

The PCM-9580F is equipped with an audio interface that records and plays back CD-quality audio. This chapter provides instructions for installing the software drivers included on the audio driver diskettes.

Chapter 6 Audio Setup

6.1 Introduction

The PCM-9580F can receive audio by connecting with PCM-231AV (AC97 Link). PCM-231AV provides high-quality stereo sound and FM music synthesis (ESFM) by using the Realtek ALC201 Audio Codec from Realtek. The audio interface can record, compress, and play back voice, sound, and music with built-in mixer control.

6.2 Driver installation

6.2.1 Before you begin

Please read the instructions in this chapter carefully before you attempt installation. For the hardware installation, first connect CN13 AC link at PCM-9580F with CN3 at PCM-231AV. The audio drivers for the PCM-231AV board are located on the audio driver CD. Run the supplied SETUP program to install the drivers; don't copy the files manually.

- Note:*
- 1. Note1: Before trying to install the driver, go to Chapter 3 to use the "Chipset Software Installation Utility" first.*
 - 2. The files on the software installation diskette are compressed. Do not attempt to install the drivers by copying the files manually. You must use the supplied SETUP program to install the drivers.*

6.2.2 Windows 9x/2000/Me/XP drivers

Step 1. Click "Start" and select "Settings". Click "Control Panel" and double-click Multimedia" icon and press " Reinstall Driver..." to do audio driver installation..

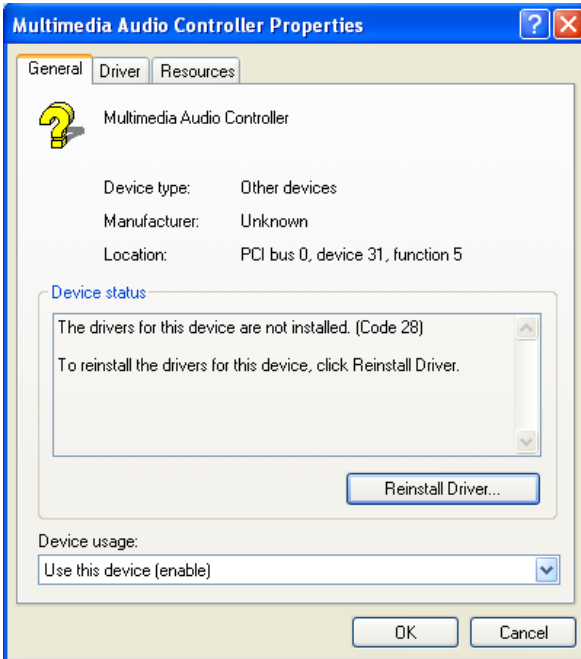

Step 2. In the Hardware Update Wizard window, click "Next".

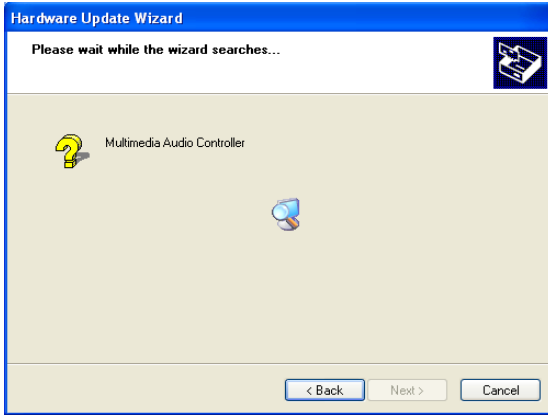

Step 3. In the following Hardware Update Wizard window, click "Finish" for Windows to complete audio driver installation.



6.2.3 Windows NT drivers

Step 1. Click "Start" and select "Settings". Click "Control Panel" and double-click "Multimedia".



Step 2. In the Multimedia Properties window, select the "Devices" tab. Then select the "Audio Devices" item, and click "Add..."

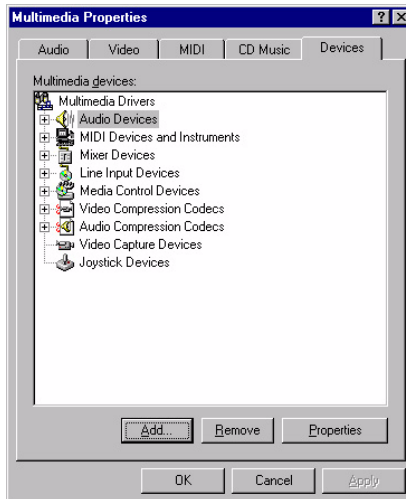

Step 3. In the Add window, select the "Unlisted..." item and click "OK".

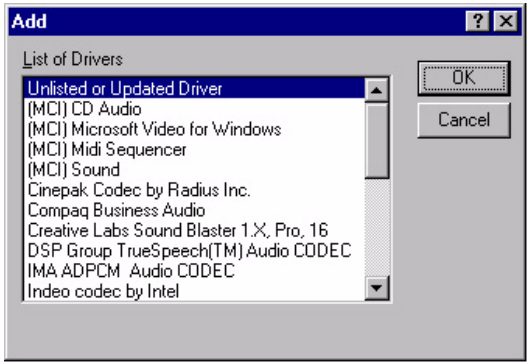

Step 4. When the Install Driver window appears, insert the utility disc into the CD-ROM drive. Type: D:\Audio\ALC201\WinNT\
Then click "OK".

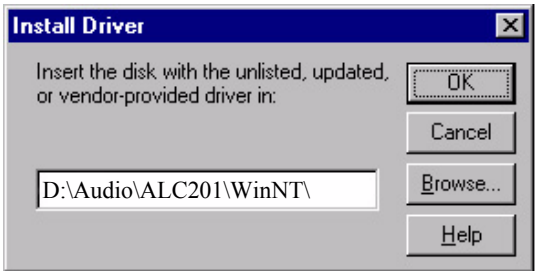

Step 5. In the Add Unlisted or Updated Driver window, select the "Avance AC'97 Audio Driver" item. Then click "OK".

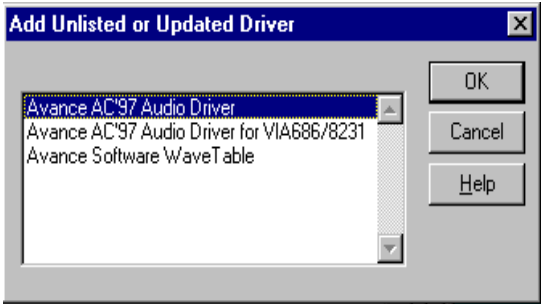

Step 6. In the System Setting Change window, click "Restart Now".



LAN Configuration

- Introduction
- Features
- Installation of Ethernet Driver for
 - Windows 2000 Drivers Setup Steps
 - Windows NT Drivers Setup Steps
 - Windows Wake-on-LAN Setup

Chapter 7 PCI Bus Ethernet Interface

7.1 Introduction

The PCM-9580F is equipped with a high-performance 32-bit Ethernet chipset which is fully compliant with IEEE 802.3 100 Mbps CSMA/CD standards. It is supported by major network operating systems. It is also both 100Base-T and 10Base-T compatible.

7.2 Features

- Intel 82551 10/100Base-T Ethernet LAN controller
- Optional Intel 82540 10/100/1000 Base-T Ethernet LAN controller
- Supports Wake-on-LAN remote control function.
- PCI Bus Master complies with PCI Rev. 2.2
- Complies with 100Base-TX, and 10Base-T applications.
- Single RJ-45 connector gives auto-detection of 10 Mbps or 100 Mbps network data transfer rates and connected cable types.
- Enhancements on ACPI & APM.
- Complies with PCI Bus Power Management Interface Rev. 1.1,
- ACPI Rev. 2.0, and Device Class Power Management Rev. 1.0.

7.3 Installation of Ethernet Driver

Before installing the Ethernet driver, note the procedures below. You must know which operating system you are using in your PCM-9580, and then refer to the corresponding installation procedure. Then just follow the steps described. You will quickly and successfully complete the installation, even if you are not familiar with instructions for Windows.

Note: *The windows illustrations in this chapter are examples only. You must follow the flow chart instructions and pay attention to the instructions which then appear on your screen.*

7.3.1 Installation for Windows 2000

Note: The CD-ROM drive is designated as "D" throughout this section.

1. Click "Setup" icon in path "D:\BISCUIT\9580\LAN\"

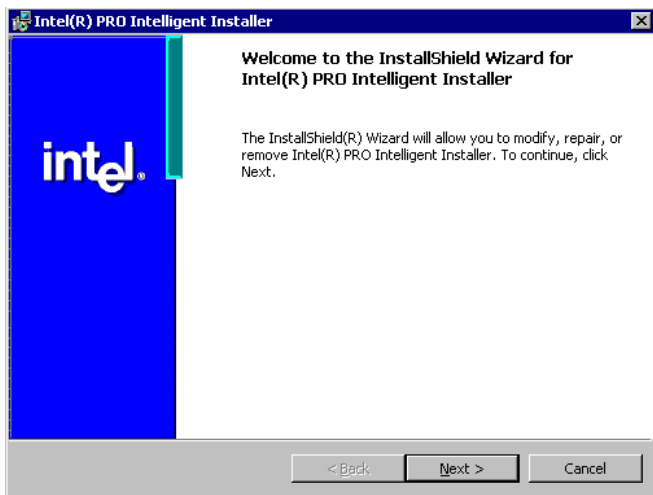

2. Choose "Modify" item and click "Next" to go next step.



3. Highlight "Drivers for wired Ethernet adapters" and click "Next".

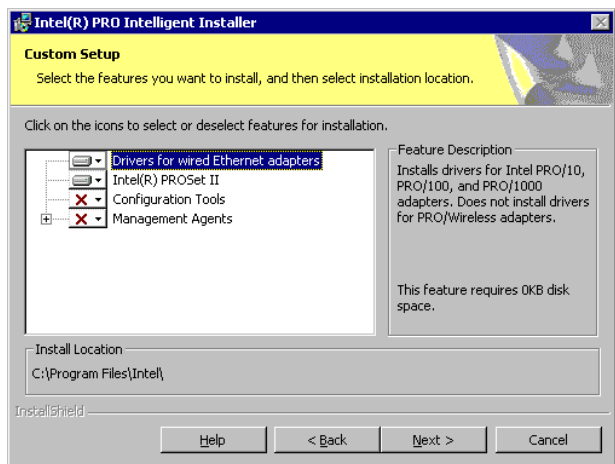

4. Click "Install" to begin the installation.

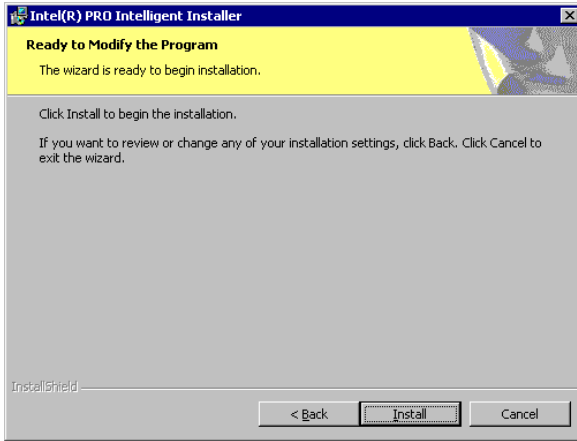

5. Click "Finish" to exit the wizard.

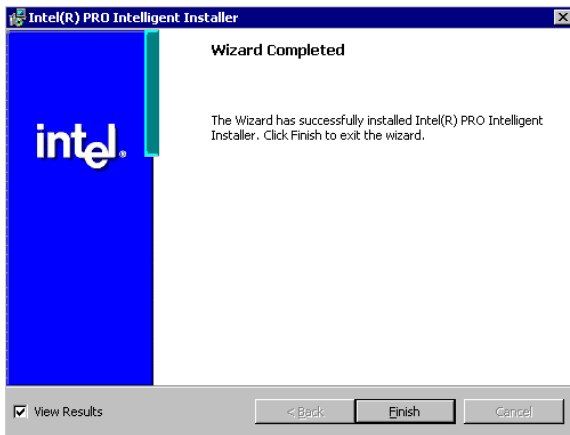

6. Then the Installer will show the result after driver installed.

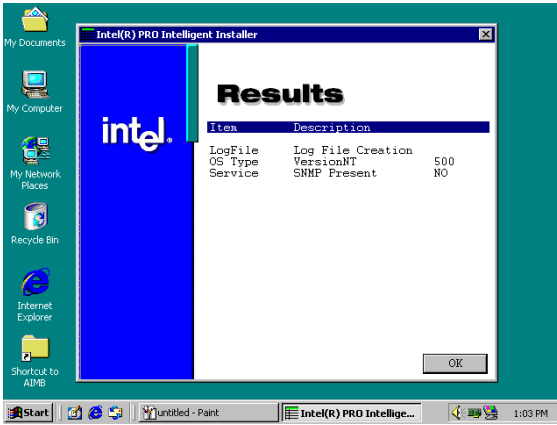

7.3.2 Installation for Windows NT

1. Select "Start", "Settings", "Control Panel" and double click "Network" icon.

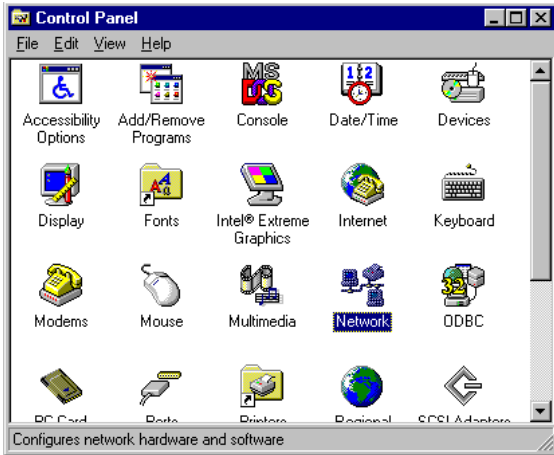

2. Then this menu will show on the screen. And click "Yes" to install network driver.

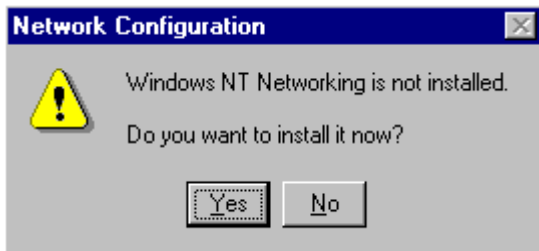

3. Select "Wired to the network" and click "Next"

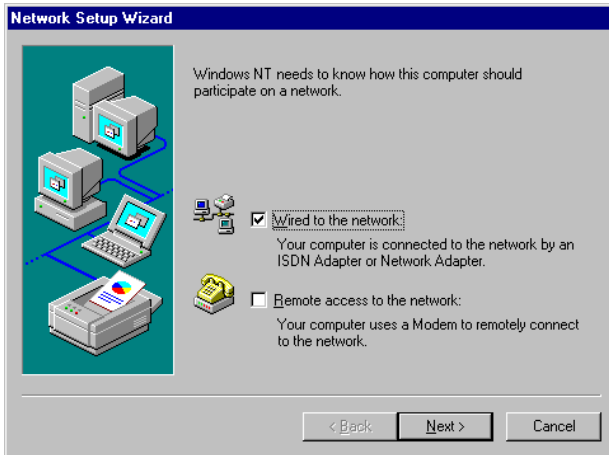

4. Click "Start Search" to search a Network Adapter. Then click "Next" to go next step

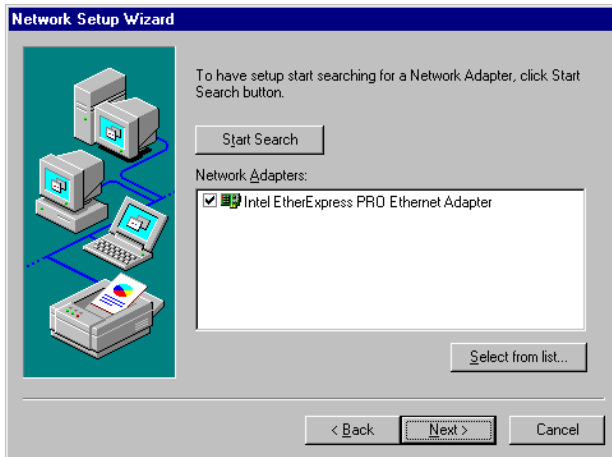

5. Base on current network environment to modify the Network Protocol then Click "Next"

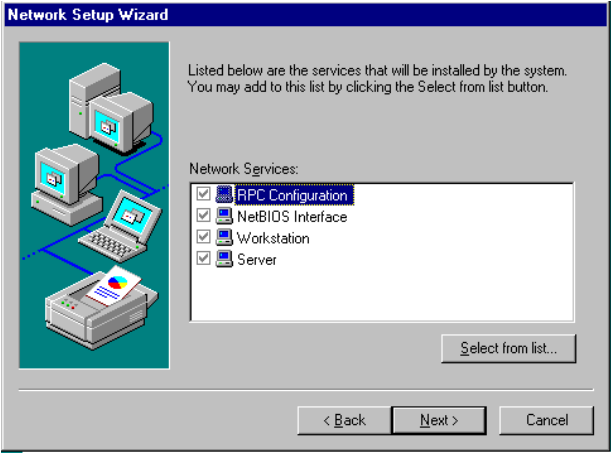
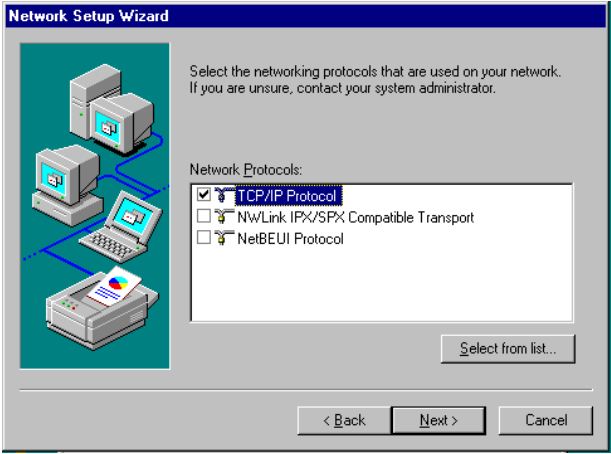

6. Click "Next" to go to next step

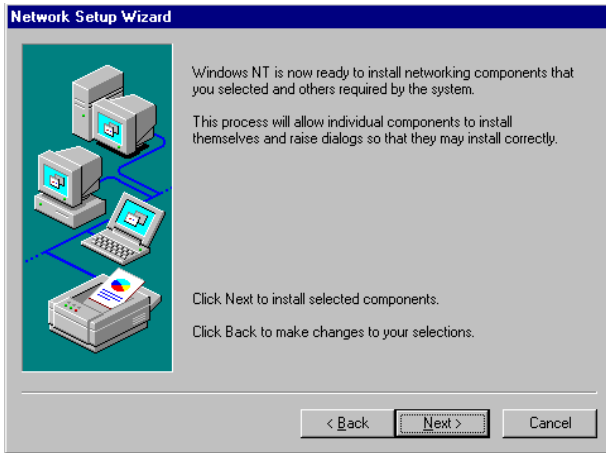

7. Click "Next" to install Network Adapter driver.



8. Check the License Agreement first then select "I accept the terms in the license agreement" and click "Next".

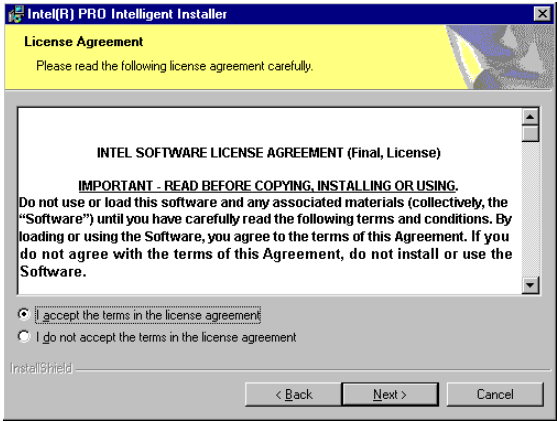

9. Select "Typical" and Click "Next".

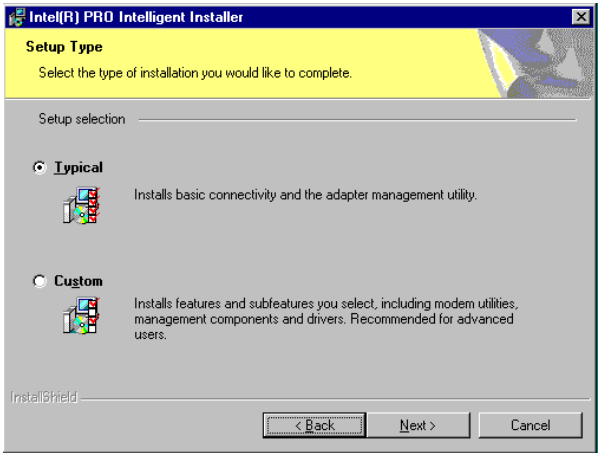

10. Click "Install" to start to install driver.

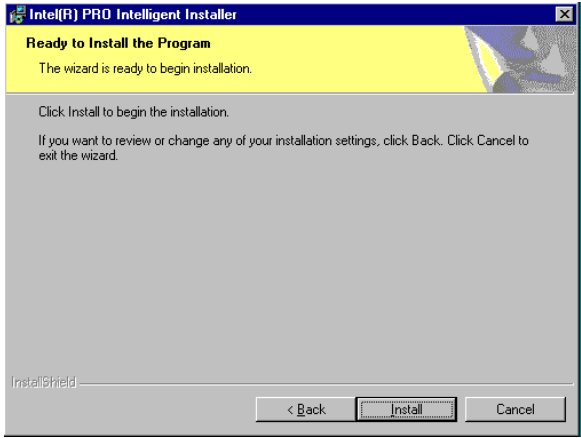

11. Click "Finish" to finish install driver.

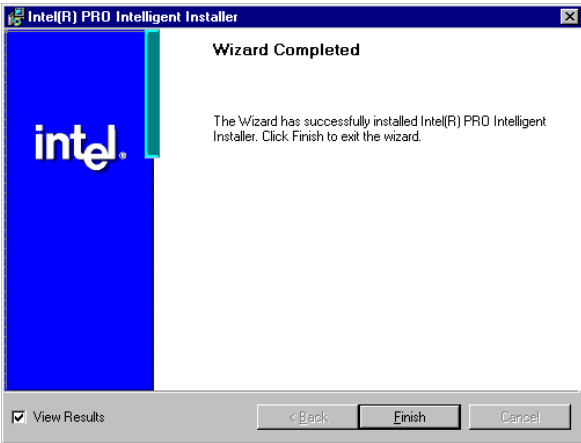

7.4 Further information

Intel website: www.intel.com

Advantech websites: www.advantech.com
www.advantech.com.tw

Programming the GPIO and Watchdog Timer

The PCM-9580 is equipped with a watchdog timer that resets the CPU or generates an interrupt if processing comes to a standstill for any reason. This feature ensures system reliability in industrial standalone or unmanned environments.

Appendix A Programming the GPIO & Waterdog Timer

A.1 Supported GPIO Register

Bellow are detailed description of the GPIO addresses and programming sample.

A.1.1 GPIO Registers

CRF0 (GP10-GP17 I/O selection register. Default 0xFF)

When set to a '1', respective GPIO port is programmed as an input port.

When set to a '0', respective GPIO port is programmed as an output port.

CRF1 (GP10-GP17 data register. Default 0x00)

If a port is programmed to be an output port, then its respective bit can be read/written.

If a port is programmed to be an input port, then its respective bit can only be read.

CRF2 (GP10-GP17 inversion register. Default 0x00)

When set to a '1', the incoming/outgoing port value is inverted.

When set to a '0', the incoming/outgoing port value is the same as in data register.

Extended Function Index Registers (EFIRs)

The EFIRs are write-only registers with port address 2Eh or 4Eh on PC/AT systems.

Extended Function Data Registers(EFDRs)

the EFDRs are read/write registers with port address 2Fh or 4Fh on PC/AT systems.

A.1.2 GPIO Example program-1

Enter the extended function mode, interruptible double-write

```
MOV DX,2EH
MOV AL,87H
OUT DX,AL
OUT DX,AL
```

Configure logical device 7(GP10~GP17), configuration register
CRF0,CRF1,CRF2

```
MOV DX,2EH
MOV AL,07H ; point to Logical Device Number Reg.
OUT DX,AL
MOV DX,2FH
MOV AL,07H ; select logical device 7
OUT DX,AL ;
MOV DX,2EH
MOV AL,F0
OUT DX,AL
MOV DX,2FH
MOV AL,00H ; 01:Input 00:output for GP10~GP17
OUT DX,AL
MOV DX,2EH
MOV AL,F2H ;
OUT DX,AL
MOV DX,2FH
MOV AL,00H ;Set GPIO is normal not inverter
OUT DX,AL;
MOV DX,2EH
MOV AL,F1H
```

```
OUT DX,AL
MOV DX,2FH
MOV AL,??H ; Put the output value into AL
OUT DX,AL
```

Exit extended function mode

```
MOV DX,2EH
MOV AL,AAH
OUT DX,AL
```

A.2 Watchdog programming

Bellow is a sample of programming code for controlling the Watchdog Timer function.

Enter the extended function mode ,interruptible double-write

```
MOV DX,2EH
MOV AL,87H
OUT DX,AL
OUT DX,AL
```

Configure logical device 8, configuration register CRF6

```
MOV DX,2EH
MOV AL,07H ; point to Logical Device Number Reg.
OUT DX,AL
MOV DX,2FH
MOV AL,08H ; select logical device 8
OUT DX,AL ;
MOV DX,2EH
MOV AL,30H ;Set watch dog activate or inactivate
OUT DX,AL
MOV DX,2FH
MOV AL,01H ; 01:activate 00:inactivate
OUT DX,AL ;
MOV DX,2EH
MOV AL,F5H ; Setting counter unit is second
OUT DX,AL
MOV DX,2FH
MOV AL,00H
OUT DX,AL;
```

```
MOV DX,2EH
MOV AL,F6H
OUT DX,AL
MOV DX,2FH
MOV AL,05H ; Set 5 seconds
OUT DX,AL
```

```
;-----
```

```
; Exit extended function mode |
```

```
;-----
```

```
MOV DX,2EH
MOV AL,AAH
OUT DX,AL
```

Pin Assignments

This appendix provides specialized information regarding:

- CPU Fan Power Connector
- Ethernet 10/100Base-T Connector
- Ethernet 100/1000Base-T Connector
- Audio Connector
- CD Drive Connector
- Main Power Connector
- Keyboard and PS/2 Mouse Connector
- Floppy Drive Connector
- PC/104 Connector
- IDE (1st and 2nd) HDD Connector
- Parallel Port Connector
- Power & HDD LED, Reset Button Connector
- USB Connector
- Backlight Connector
- IR Connector
- CRT Display Connector
- TV-out Connector
- Flat Panel Connector
- Ext. Flat Panel Connector
- LCD Signal Mapping
- Peripheral power connector
- LVDS Interface Connector
- COM Port Connector
- CompactFlash Card Connector
- ATX Power Feature Connector
- 8 bit GPIO Connector

Appendix B Pin Assignments

B.1 System fan power connector (FAN1) CPU fan connector (FAN 2)



*Table B.1: System fan power connector (FAN 1)
CPU Fan Power Connector (FAN 2)*

Pin	Signal
1	GND
2	+12V
3	Detect

B.2 Ethernet 10/100Base-T Connector (CN25)

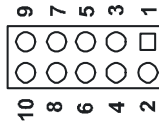

Table B.2: Ethernet 10/100Base-T connector (CN25)

Pin	Signal
1	VCC
2	CRS LED
3	RCV+
4	RCV-
5	BNC LED
6	GND
7	N/C
8	GND
9	XMT+
10	XMT-

B.3 Ethernet 10/100/1000 BASE-T connector (CN26)

Table B.3: Ethernet 100/1000-T connector (CN26)

Pin	Signal
1	NC
2	NC
3	MDI_3+ signal
4	MDI_3- signal
5	MDI_2+ signal
6	MDI_2- signal
7	MDI_1+ signal
8	MDI_1- signal
9	MDI_0+ signal
10	MDI_0- signal1

B.4 Ethernet LED connector (CN27)

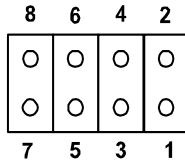

Table B.4: Giga bit Ethernet LED (CN27)

Pin	Signal
1	VCC
2	GND
3	LINK
4	ACT.
5	LINK100
6	LINK1000
7	NC
8	NC

B.5 ACLink audio connector (CN4)

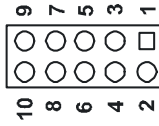

Table B.5: Table A-15: Audio connector

Pin	Signal	Pin	Signal
1	+5V	2	Bit clock signal
3	SDATIN	4	GND
5	GND	6	SYNC Signal
7	S DATOUT	8	Reset
9	+5V	10	N.C.

B.6 ATX Main Power Connector (CN6)

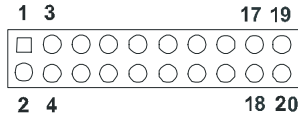

Table B.6: ATX power connector (CN6)

Pin	Pin name	Pin	Pin name
1	3.3V	11	3.3V
2	3.3V	12	-12V
3	GND	13	GND
4	+5V	14	PSON*
5	GND	15	GND
6	+5V	16	GND
7	GND	17	GND
8	PWROK	18	-5V
9	+5VSB	19	+5V
10	+12V	20	+5V

B.7 ATX 12V power connector (CN10)

Table B.7: ATX 12 V power connector

Pin	Signal
1	GND
2	+12V
3	+12V
4	GND

B.8 Keyboard and PS/2 Mouse Connector (CN17)

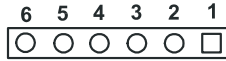

Table B.8: Keyboard and mouse connector (CN17)

Pin	Signal
1	KB CLOCK
2	KB DATA
3	MS CLOCK
4	GND
5	+5V (KB VCC)
6	MS DATA

B.9 Floppy Disk Drive Connector (CN12)

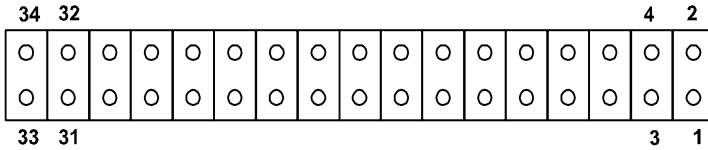

Table B.9: Floppy Disk Drive Connector (CN12)

Pin	Signal	Pin	Signal
1	GND	2	DENSITY SELECT*
3	GND	4	N/C
5	GND	6	N/C
7	GND	8	INDEX*
9	GND	10	MOTOR 0*
11	GND	12	DRIVE SELECT 1*
13	GND	14	DRIVE SELECT 0*
14	GND	16	MOTOR 1*
17	GND	18	DIRECTION*
19	GND	20	STEP*
21	GND	22	WRITE DATA*
23	GND	24	WRITE GATE*
25	GND	26	TRACK 0*
27	GND	28	WRITE PROTECT*
29	GND	30	READ DATA*
31	GND	32	HEAD SELECT*
33	GND	34	DISK CHANGE*

*low active

B.10 IDE Hard Drive Connector (CN15, CN13)

Table B.10: IDE HDD connector (CN15, CN13)

Pin	Signal	Pin	Signal
1	IDE RESET*	2	GND
3	DATA 7	4	DATA 8
5	DATA 6	6	DATA 9
7	DATA 5	8	DATA 10
9	DATA 4	10	DATA 11
11	DATA 3	12	DATA 12
13	DATA 2	14	DATA 13
15	DATA 1	16	DATA 14
17	DATA 0	18	DATA 15
19	SIGNAL GND	20	N/C
21	REQ	22	GND
23	IO WRITE	24	GND
25	IO READ	26	GND
27	HD READY	28	N/C
29	HDACK 0*	30	GND
31	IRQ14	32	N/C
33	ADDR 1	34	66DET
35	ADDR 0	36	ADDR 2
37	HARD DISK SELECT 0*	38	HARD DISK SELECT 1*
39	IDE ACTIVE*	40	GND
41	VCC	42	VCC
43	GND	44	N/C

* low active

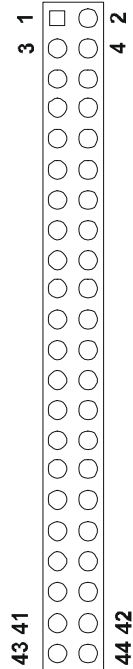

B.11 Parallel Port Connector (CN11)

Table B.11: Parallel Port Connector (CN11)

Pin	Signal	Pin	Signal
1	STROBE*	2	AUTOFD*
3	D0	4	ERR
5	D1	6	INIT*
7	D2	8	SLCTINI*
9	D3	10	GND
11	D4	12	GND
13	D5	14	GND
15	D6	16	GND
17	D7	18	GND
19	ACK*	20	GND
21	BUSY	22	GND
23	PE	24	GND
25	SLCT	26	N/C

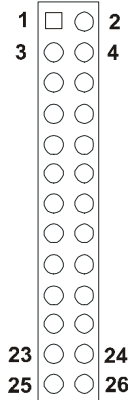

* low active

B.12 Front Panel (CN14)

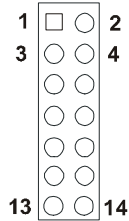

Table B.12: 1 HDD LED +

Pin	Signal
1	HDD LED +
2	HDD LED -
3	Power Good +
4	GND (Power Good -)
5	NC
6	NC
7	LAN Act. +
8	LAN Act. -
9	LAN Link +
10	LAN Link -
11	ATX Power Button
12	ATX Power Button
13	GND (Reset)
14	Reset

B.13 USB Connector (CN1)

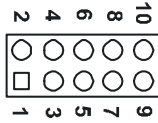

Table B.13: USB Connector (CN1)

Pin	Signal	Pin	Signal
1	+5 V	2	+5 V
3	DAT3-	4	DAT4-
5	DAT3+	6	DAT4+
7	GND	8	GND
9	Chassis GND	10	N/C

B.14 Embedded USB Connector (CN23)

Table B.14: USB Connector (CN23)

Pin	Signal	Pin	Signal
1	GND	2	GND
3	GND (USB)	4	GND (USB)
5	Vcc (USB)	6	Vcc (USB)
7	Data 1-	8	Data 2-
9	Data 1+	10	Data 2+
11	GND (USB)	12	GND (USB)
13	Key	14	N.C / Over current
15	Vcc 5 V	16	N.C / Vcc 3.3 V
17	GND	18	GND

B.15 LCD Inverter Backlight Connector (CN3)

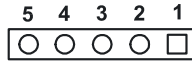

Table B.15: LCD Inverter Backlight Connector (CN3)

Pin	Signal
1	+12 V
2	GND
3	ENABKL
4	VBR
5	+5 V

B.16 CRT Display Connector (CN9)

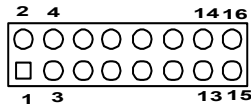

Table B.16: CRT Display Connector (CN9)

Pin	Signal	Pin	Signal
1	RED	2	RED.
3	GREEN	4	GND
5	BLUE	6	N/C
7	N/C	8	VGA Data
9	GND	10	H-sync signal
11	GND	12	V-sync signal
13	GND	14	DDC CLK
15	GND	16	N/C

B.17 TV (video) Out Connector (CN2)

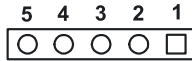

Table B.17: TV (video) Out Connector (CN2)

Pin	Signal
1	Luminance out (S-Video Y output, brightness)
2	Chrominance out (S-Video C output, color)
3	GND
4	GND
5	N/C

B.18 LVDS Connector (CN5)

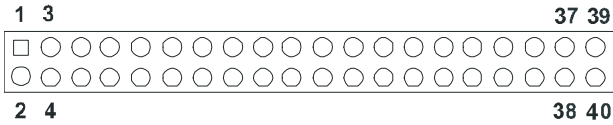

Table B.19: LVDS Connector (CN5)

Pin	Signal	Pin	Signal
Pin-1	VDDSAFE (Select by JP1)	Pin-2	VDDSAFE (Select by JP1)
Pin-3	GND	Pin-4	GND
Pin-5	VDDSAFE (Select by JP1)	Pin-6	VDDSAFE (Select by JP1)
Pin-7	LVDS-0N	Pin-8	LVDS_4N
Pin-9	LVDS_0P	Pin-10	LVDS-4P
Pin-11	GND	Pin-12	GND
Pin-13	LVDS-1N	Pin-14	LVDS-5N
Pin-15	LVDS_1P	Pin-16	LVDS_5P
Pin-17	GND	Pin-18	GND
Pin-19	LVDS-2N	Pin-20	LVDS-6N
Pin-21	LVDS_2P	Pin-22	LVDS_6P
Pin-23	GND	Pin-24	GND
Pin-25	LVDS-C1N	Pin-26	LVDS-C2N
Pin-27	LVDS_C1P	Pin-28	LVDS_C2P
Pin-29	GND	Pin-30	GND
Pin-31	DDC_CLK	Pin-32	DDC_DATA
Pin-33	GND	Pin-34	GND
Pin-35	LVDS_C3N	Pin-36	LVDS-C7N
Pin-37	LVDS_C3P	Pin-38	LVDS_C7P
Pin-39	HPLG_DTS	Pin-40	VCON

B.19 COM Port Connector (CN7)

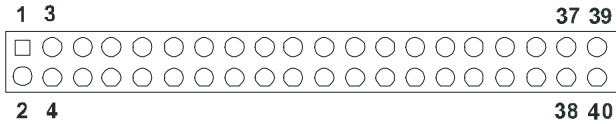

Table B.18: COM Port Connector (CN7)

Pin	Signal	Pin	Signal
1	RLSD1 (DCD1)	2	DSR1
3	RX1	4	RTS1
5	TX1	6	CTS1
7	DTR1	8	RI1
9	GND	10	GND
11	RLSD2 (DCD2)	12	DSR2
13	RX2	14	RTS2
15	TX2	16	CTS2
17	DTR2	18	RI2
19	GND	20	GND
21	RLSD3 (DCD3)	22	DSR3
23	RX3	24	RTS3
25	TX3	26	CTS3
27	DTR3	28	RI3
29	GND	30	GND
31	RLSD4 (DCD4)	32	DSR4
33	RX4	34	RTS4
35	TX4	36	CTS4
37	DTR4	38	RI4
39	GND	40	GND

B.20 CompactFlash Card Connector (CN19)

Table B.19: CompactFlash Card Connector (CN19)

Pin	Signal	Pin	Signal
1	GND	2	SDD3
3	SDD4	4	SDD5
5	SDD6	6	SDD7
7	SDCS#1	8	GND
9	GND	10	GND
11	GND	12	GND
13	+5V	14	GND
15	GND	16	GND
17	GND	18	SDA2
19	SDA1	20	SDA0
21	SDD0	22	SDD1
23	SDD2	24	NC
25	NC	26	NC
27	SDD11	28	SDD12
29	SDD13	30	SDD14
31	SDD15	32	SDCS#3
33	NC	34	SDIOR
35	SDIOW	36	+5V
37	IRQ15	38	+5V
39	CSEL	40	NC
41	IDERST	42	SDIORDY
43	NC	44	+5V
45	SDDASP	46	S66DET
47	SDD8	48	SDD9
49	SDD10	50	GND

B.21 GPIO Connector (CN16)

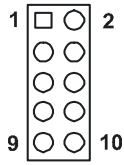

Table B.20: GPIO Connector (CN16)

Pin	Signal
1	DIO IN 0
2	DIO OUT 0
3	DIO IN 1
4	DIO OUT 1
5	DIO IN 2
6	DIO OUT 2
7	DIO IN 3
8	DIO OUT 3
9	GND
10	GND

System Assignments

This Appendix contains information of a detailed nature: It includes:

- System I/O ports
- 1st MB memory map
- DMA channel assignments
- Interrupt assignments

Appendix C System Assignments

C.1 System I/O Ports

Table C.1: System I/O Ports

Addr. range (Hex)	Device
000-01F	DMA controller
020-021	Interrupt controller 1, master
040-05F	8254 timer
060-06F	8042 (keyboard controller)
070-07F	Real-time clock, non-maskable interrupt (NMI) mask
080-09F	DMA page register
0A0-0BF	Interrupt controller 2
0C0-0DF	DMA controller
0F0	Clear math co-processor
0F1	Reset math co-processor
0F8-0FF	Math co-processor
1F0-1F8	Fixed disk
170- 178	Fixed disk (2nd IDE)
200-207	Reserved (Game I/O)
278-27F	Parallel printer port 2 (LPT 3)
2E8-2EF	Series port 4
2F8-2FF	Serial port 2
300-31F	Prototype card
360-36F	Reserved
378-37F	Parallel printer port 1 (LPT 2)
380-38F	SDLC, bisynchronous 2
3A0-3AF	Bisynchronous 1
3B0-3BF	Monochrome display and printer adapter (LPT1)
3C0-3CF	Reserved
3D0-3DF	Color/graphics monitor adapter
3E8-3EF	Series port 3
3F0-3F7	Diskette controller
3F8-3FF	Serial port 1

* PNP audio I/O map range from 220 ~ 250H (16 bytes)

Table C.1: System I/O Ports

Addr. range (Hex)	Device
-------------------	--------

MPU-401 select from 300 ~ 330H (2 bytes)	
--	--

C.2 1st MB memory map

Table C.2: 1st MB memory map

Addr. range (Hex)	Device
-------------------	--------

F0000h - FFFFFh	System ROM
-----------------	------------

*CC000h - EFFFFh	Unused (reserved for Ethernet ROM)
------------------	------------------------------------

C0000h - CBFFFh	Expansion ROM (for VGA BIOS)
-----------------	------------------------------

B8000h - BFFFFh	CGA/EGA/VGA text
-----------------	------------------

B0000h - B7FFFh	Unused
-----------------	--------

A0000h - AFFFFh	EGA/VGA graphics
-----------------	------------------

00000h - 9FFFFh	Base memory
-----------------	-------------

* If Ethernet boot ROM is disabled (Ethernet ROM occupies about 16 KB)

* E0000 - EFFFF is reserved for BIOS POST

C.3 DMA channel assignments

Table C.3: DMA channel assignments

Channel	Function
---------	----------

0	Available
---	-----------

1	Reserved (audio)
---	------------------

2	Floppy disk (8-bit transfer)
---	------------------------------

3	Available (parallel port)
---	---------------------------

4	Cascade for DMA controller 1
---	------------------------------

5	Available
---	-----------

6	Available
---	-----------

7	Available
---	-----------

* Audio DMA select 1, 3, or 5

** Parallel port DMA select 1 (LPT2) or 3 (LPT1)

C.4 Interrupt assignments

Table C.4: Interrupt assignments

Interrupt#	Interrupt source
IRQ 0	Interval timer
IRQ 1	Keyboard
IRQ 2	Interrupt from controller 2 (cascade)
IRQ 3	COM2
IRQ 4	COM1
IRQ 5	COM4
IRQ 6	FDD
IRQ 7	LPT1
IRQ 8	RTC
IRQ 9	Reserved (audio)
IRQ 10	COM3
IRQ 11	Reserved for watchdog timer
IRQ 12	PS/2 mouse
IRQ 13	INT from co-processor
IRQ 14	Primary IDE
IRQ 15	Secondary IDE for CFC

* Ethernet interface IRQ select: 9, 11, 15

* PNP audio IRQ select: 9, 11, 15

* PNP USB IRQ select: 9, 11, 15

* PNP ACPI IRQ select: 9, 11, 15

Appendix

D

**Optional Extras for the
PCM-9580**

Appendix D Optional Extras

The PCM-9580F requires several cables for normal operation. You can make them yourself or purchase an optional cable kit assembly, which includes the following:

D.1 PCM-10586-6000 Cable kit for PCM-9580F

Table D.1: PCM-10586-6000 wiring kit for PCM-9580F

Part No.	Cable Description	PCM-9580F Connector	Terminating Connector
1701440350	2.5" and 1.8" IDE	CN13	2 x 8 pin header (2 mm) 15-pin DSUB
1701400452	3.5" IDE DMA/66 (40pin)	CN15	40pin, 2.54 mm, female IDC (450 mm)
1701340603	Dual Floppy, 3.5" and 5.25"(34p)	CN12	40-pin, 2.54 mm, female IDC(450 mm)
1701260250	Parallel Port	CN11	34-pin Dual Floppy
1701100202	Network, 100-Base-T	CN25	25-pin female DSUB
1701160101	VGA CRT	CN9	RJ45 8-pin modular jack
1703060191	Keyboard and PS/2 mouse	CN17	5-pin circular DIN, 6-pin circular DIN
1701140300	Front panel cable power (-5V and -12V)	CN14	(3-conductor)
1703400156	COM 1 - 4 cable	CN7	40-pin, 9-pin male DSUB x4
1700180170	USB Channel 3,4	CN23	17cm 2CH W/ Guard Hole NO.13P 18-pin
1701140300	Front Panel Cable	CN14	CN14 FLAT CABLE14P-2.0mm 30cm
1703100260	USB cable	CN1	10-pin, IDE 2.0mm, USBx2 (26cm)

D.2 PCM-10586-6G00 Cable kit for PCM-9580FG

Table D.2: PCM-10586-6G00 wiring kit for PCM-9580FG

Part No.	Cable Description	PCM-9580F Connector	Terminating Connector
1701440350	2.5" and 1.8" IDE	CN13	2 x 8 pin header (2 mm) 15-pin DSUB
1701400452	3.5" IDE DMA/66 (40pin)	CN15	40pin, 2.54 mm, female IDC (450 mm)
1701340603	Dual Floppy, 3.5" and 5.25" (34p)	CN12	40-pin, 2.54 mm, female IDC (450 mm)
1701260250	Parallel Port	CN11	34-pin Dual Floppy
1701100151	Network, 100-Base-T	CN26	25-pin female DSUB
1701160101	VGA CRT	CN9	RJ45 8-pin modular jack
1703060191	Keyboard and PS/2 mouse	CN17	5-pin circular DIN, 6-pin circular DIN
1701140300	Front panel cable power (-5V and -12V)	CN14	(3-conductor)
1703400156	COM 1 - 4 cable	CN7	40-pin, 9-pin male DSUB x4
1700180170	USB Channel 3,4	CN23	17cm 2CH W/ Guard Hole NO.13P 18-pin
1701140300	Front Panel Cable	CN14	FLAT CABLE 14P-2.0mm 30cm
1703100260	USB cable	CN1	10-pin, IDE 2.0mm, USBx2 (26cm)

D.3 Optional USB cable (CN1 or CN23)

Optional USB cable (10-pin,26 cm)	Part no: 1703100260
Optional USB cable 18pin, 17cm	Part no. 1700180170
Optional USB cable (10pin,12cm) for MBPC-300	Part no. 1703100121

D.4 ATX Power Control Cable (CN10)

part no.: 1703070101

Appendix

E

Mechanical Drawings

Appendix E Mechanical Drawings

E.1 Mechanical Drawings

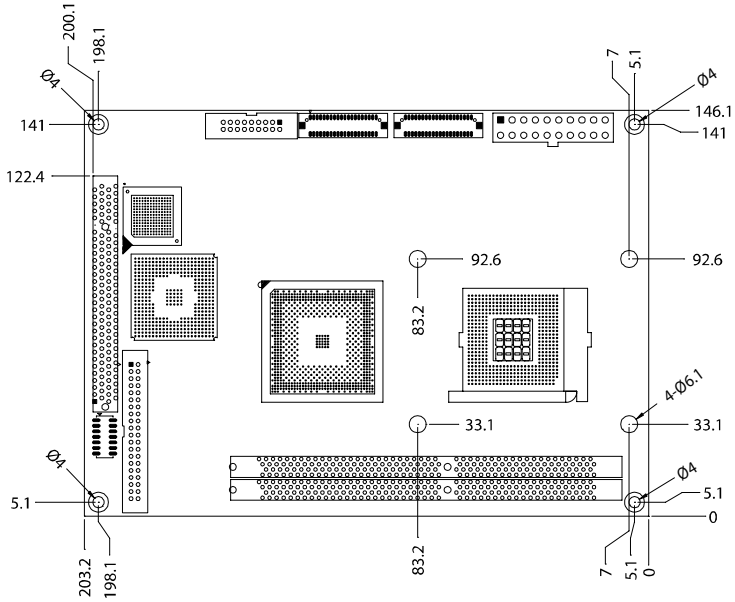

Figure E.1: PCM-9580 Mechanical Drawing (component side)

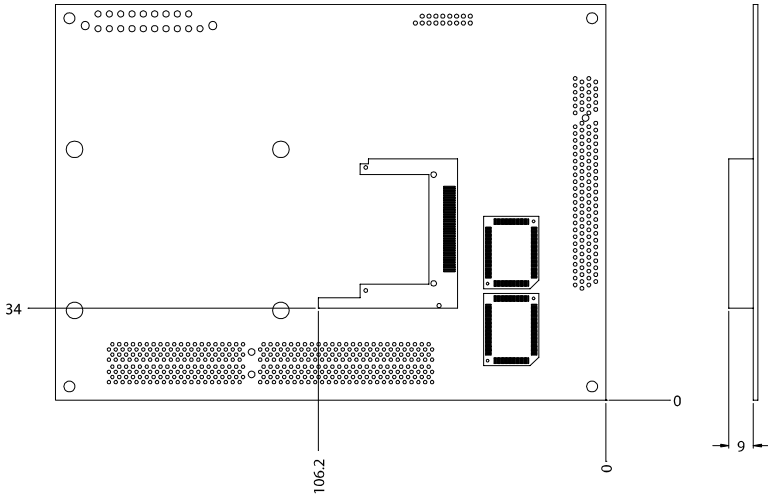

Figure E.2: PCM-9580 Mechanical Drawing (solder side)

