

PCM-4380

**Pentium® M 4" EPIC SBC with
MIO/VGA/LCD/LVDS Ethernet/
USB2.0 and SSD**

User Manual

Copyright

This document is copyrighted, © 2007. All rights are reserved. The original manufacturer reserves the right to make improvements to the products described in this manual at any time without notice.

No part of this manual may be reproduced, copied, translated or transmitted in any form or by any means without the prior written permission of the original manufacturer. Information provided in this manual is intended to be accurate and reliable. However, the original manufacturer assumes no responsibility for its use, nor for any infringements upon the rights of third parties that may result from such use.

Acknowledgements

Award is a trademark of Award Software International, Inc. VIA is a trademark of VIA Technologies, Inc.

IBM, PC/AT, PS/2 and VGA are trademarks of International Business Machines Corporation.

Intel, Pentium, Celeron, and MMX are registered trademarks of Intel Corporation.

Microsoft Windows® is a registered trademark of Microsoft Corp.

RTL is a trademark of Realtek Semi-Conductor Co., Ltd.

ESS is a trademark of ESS Technology, Inc.

UMC is a trademark of United Microelectronics Corporation. SMI is a trademark of Silicon Motion, Inc.

Creative is a trademark of Creative Technology LTD.

All other product names or trademarks are properties of their respective owners.

For more information on this and other Advantech products, please visit our websites at: <http://www.advantech.com>

<http://www.advantech.com/eplatform>

For technical support and service, please visit our support website at: <http://www.advantech.com/support>

Part No. 2006438010

Edition 1

Printed in Taiwan

April 2007

Packing List

Before you begin installing your card, please make sure that the following materials have been shipped:

Item	Part Number
1 Startup manual	
1 Utility CD	
1 mini jumper pack	9689000002
FLAT Cable 44P 20CM 3Com & LPT 1.27mm to D-sub	1700002034
FLAT Cable 44P IDC 44P/44P/40P keyed 50CM	1701440504
Cable 20P/10P 10CM EPIC ATX Power	1700002055
Cable 6pin, 6-pin; 20CM long: PS/2 KB & Mouse	1700060202

If any of these items are missing or damaged, contact your distributor or sales representative immediately.

Model Number	Description
PCM-4380F-S4A1E	Pentium M 1.4GHz w/Audio/VGA/LCD/CFC
PCM-4380F-S0A1E	Celeron M 1.0GHz w/Audio/VGA/LCD/CFC
PCM-4380U-S4A1E	Pentium M 1.4GHz w/Audio/VGA/LCD/USB- DOM
PCM-4380U-S0A1E	Celeron M 1.0GHz w/Audio/VGA/LCD/USB- DOM

Additional Information and Assistance

1. Visit the Advantech web site at www.advantech.com where you can find the latest information about the product.
2. Contact your distributor, sales representative, or Advantech's customer service center for technical support if you need additional assistance.

Please have the following information ready before you call:

- Product name and serial number
- Description of your peripheral attachments
- Description of your software (operating system, version, application software, etc.)
- A complete description of the problem
- The exact wording of any error messages

FCC

This device complies with the requirements in part 15 of the FCC rules: Operation is subject to the following two conditions:

1. This device may not cause harmful interference, and
2. This device must accept any interference received, including interference that may cause undesired operation

This equipment has been tested and found to comply with the limits for a Class A digital device, pursuant to Part 15 of the FCC Rules. These limits are designed to provide reasonable protection against harmful interference when the equipment is operated in a commercial environment. This equipment generates, uses, and can radiate radio frequency energy and, if not installed and used in accordance with the instruction manual, may cause harmful interference to radio communications. Operation of this device in a residential area is likely to cause harmful interference in which case the user will be required to correct the interference at his/her own expense. The user is advised that any equipment changes or modifications not expressly approved by the party responsible for compliance would void the compliance to FCC regulations and therefore, the user's authority to operate the equipment.

Caution! *There is a danger of a new battery exploding if it is incorrectly installed. Do not attempt to recharge, force open, or heat the battery. Replace the battery only with the same or equivalent type recommended by the manufacturer. Discard used batteries according to the manufacturer's instructions*



Contents

Chapter 1	General Information	2
1.1	Introduction	2
1.2	Specifications	2
1.2.1	Standard 4" Biscuit SBC Functions	2
1.2.2	VGA/LVDS Interface	3
1.2.3	Ethernet Interface	3
1.2.4	Audio Function	3
1.2.5	Mechanical and Environmental	4
1.3	Board layout and dimensions	4
	Figure 1.1 Board layout: Dimensions (Component Side).....	4
	Figure 1.2 Board layout: Dimensions (Solder Side) ..	5
Chapter 2	Installation	8
2.1	Jumpers.....	8
2.1.1	Jumper Location	8
	Table 2.1 Jumpers	8
2.1.2	Jumper Settings.....	8
	Table 2.2 LCD Power (J2).....	8
	Table 2.3 COM2 Setting (J3).....	8
	Table 2.4 PCI-VIO Setting (J4).....	8
	Table 2.5 CMOS clear (S2)	9
2.2	Connectors.....	10
	Table 2.6 Connectors	10
2.3	Locating Connectors	11
	Figure 2.1 Connectors (component side).....	11
	Figure 2.2 Connectors (solder side).....	11
2.4	Setting Jumpers	12
2.5	Installing SO-DIMM.....	13
2.6	IDE, CDROM hard drive connector (CN27)	13
	2.6.1 Connecting the hard drive	14
2.7	Solid State Disk.....	14
	2.7.1 CompactFlash (CN11)	14
2.8	Parallel port connector (CN30)	14
2.9	Keyboard and PS/2 mouse connector (CN9)	15
2.10	Power & HDD LED Connector (CN13)	15
	2.10.1 Power & HDD LED Connector(CN10).....	15
	2.10.2 Power Reset button (S1)	15
2.11	Power connectors (CN1)	15
	2.11.1 Main power connector, +3.3V, +5 V, +12 V (CN3).....	15
	2.11.2 Fan power supply connector (CN5).....	15

2.12	Audio interfaces (CN31).....	15
2.12.1	Audio connector (CN31).....	15
2.13	COM port connector (CN21,CN30).....	16
2.13.1	COM2 RS-232/422/485 setting (J3).....	16
	Table 2.7 J3: COM2 RS-232/422/485 select.....	16
2.14	VGA/LCD/LVDS interface connections.....	16
2.14.1	CRT display connector (CN16).....	16
2.14.2	LVDS LCD panel connector (CN14).....	16
2.15	Ethernet configuration.....	17
2.15.1	100Base-T/1000Base-T connector (CN8, CN9).....	17
2.15.2	Network boot (Depends on Ethernet Controller Gigabit Ethernet only).....	17
2.16	Watchdog timer configuration.....	17
2.17	USB connectors (CN31,CN18, CN28).....	17
2.18	GPIO (General Purpose Input Output) (CN7).....	18
Chapter 3	Chipset Software Installation Utility.....	20
3.1	Before you begin.....	20
3.2	Introduction.....	21
3.3	Installing the CSI Utility.....	21
Chapter 4	Award BIOS Setup.....	26
4.1	Introduction.....	26
4.1.1	CMOS RAM Auto-backup and Restore.....	26
4.2	Entering Setup.....	27
	Figure 4.1 Award BIOS Setup initial screen.....	27
4.3	Standard CMOS Setup.....	28
	Figure 4.2 Standard CMOS features screen.....	28
4.4	Advanced BIOS Features.....	29
	Figure 4.3 Advanced BIOS features screen.....	29
4.4.1	Virus Warning.....	29
4.4.2	L1 & L2 Cache.....	29
4.4.3	Quick Power On Self Test.....	30
4.4.4	First/Second/Third/Other Boot Device.....	30
4.4.5	Boot Up NumLock Status.....	30
4.4.6	Gate A20 Option.....	30
4.4.7	Typematic Rate Setting.....	30
4.4.8	Typematic Rate (Chars/Sec).....	30
4.4.9	Typematic Delay (msec).....	30
4.4.10	Security Option.....	31
4.4.11	APIC Mode.....	31
4.4.12	MPS Version Control For OS.....	31
4.5	Integrated Peripherals.....	31
4.5.1	IDE Master/Slave PIO/UDMA Mode.....	31
4.5.2	On-Chip Secondary PCI IDE.....	32

	Figure 4.4 Integrated peripherals	32
4.5.3	USB Controller	32
4.5.4	USB Keyboard/Mouse Support	32
4.5.5	AC97 Audio	32
4.5.6	Init Display First	32
4.5.7	IDE HDD Block Mode	33
4.5.8	Onboard Serial Port	33
4.5.9	Onboard Parallel Port.....	33
4.5.10	Parallel Port Mode	33
4.5.11	EPP Mode Select	33
4.5.12	ECP Mode Use DMA	33
4.6	Power Management Setup.....	34
	Figure 4.5 Power management setup screen.....	34
4.6.1	Power-Supply Type	34
4.6.2	ACPI function	34
4.6.3	Power Management	35
4.6.4	Video Off In Suspend	35
4.6.5	Modem Use IRQ.....	35
4.6.6	HDD Power Down.....	35
4.6.7	Soft-Off by PWR-BTTN	35
4.6.8	PowerOn By LAN(GigaLAN option).....	36
4.6.9	PowerOn By Ring	36
4.6.10	PowerOn By Alarm	36
4.6.11	Primary IDE 0 (1) and Secondary IDE 0 (1)	36
4.6.12	FDD, COM, LPT PORT	36
4.6.13	PCI PIRQ [A-D]#	36
4.7	PnP/PCI Configurations	37
4.7.1	PnP OS Installed	37
	Figure 4.6 PnP/PCI configurations screen	37
4.7.2	Reset Configuration Data.....	37
4.7.3	Resources controlled by:.....	37
4.7.4	PCI/VGA Palette Snoop	37
4.8	Password Setting	38
4.9	Save & Exit Setup	38
4.10	Exit Without Saving.....	38
Chapter 5	PCI SVGA/LCD Setup	40
5.1	Introduction	40
5.1.1	CMOS setting for panel type	40
5.1.2	Display type	40
5.1.3	Dual Independent Display	40
5.2	Connections to Two Standard LCDs.....	43
5.2.1	LG LM 150x06 (1024x768 LVDS LCD).....	43
	Table 5.1 Connections to LCD/Flat Panel (CN1)...	43
5.2.2	AU M170EG01 (1024x768 LVDS LCD @ 36bit).....	44

	Table 5.2 Connections to AU M170EG01 (CN1) ..	44
5.3	Installation of the SVGA Driver	45
	5.3.1 Installation of Windows 2000.....	45
5.4	Further Information	48
Chapter 6	Audio Setup.....	50
6.1	Introduction	50
6.2	Driver installation.....	50
	6.2.1 Before you begin.....	50
	6.2.2 Windows 98 drivers.....	51
Chapter 7	Ethernet Interface	56
7.1	Introduction	56
7.2	Installation of Ethernet driver	56
	7.2.1 Installation for Windows 2000	56
7.3	Further information	62
Chapter 8	Installing MIO Modules	64
8.1	MIO Introduction	64
	8.1.1 M2M concept.....	64
	8.1.2 Easy to have wireless technology with your embedded motherboard.....	64
	8.1.3 The best board combination for a system	64
	Figure 8.1 PCM-4380 + MIO 2320	64
8.2	Optional Modules.....	65
	8.2.1 MIO-2310 Wireless module	65
	8.2.2 MIO-2320 GSM/GPRS module.....	65
	8.2.3 MIO-3121 Mini-PCI to 4 COMs module	65
	8.2.4 MIO-3140 Mini-PCI to 2 SATA module	65
	8.2.5 MIO-3150 Mini-PCI to Video Capture module	65
8.3	MIO drawings	66
	Figure 8.2 MIO module mounting diagram.....	66
Appendix A	Programming the GPIO and Watchdog Timer	68
A.1	Supported GPIO Register.....	68
	A.1.1 GPIO Registers	68
	A.1.2 GPIO Example program-1	68
Appendix B	Pin Assignments	72
B.1	ATX Power connector (CN1)	72
	Table B.1 ATX Power connector (CN1).....	72
B.2	Battery connector (CN4).....	72
	Table B.2 Battery connector (CN4)	72
B.3	System FAN (CN5).....	73
	Table B.3 System FAN (CN5)	73
B.4	Power Switch (CN6)	73

	Table B.4 Power Switch (CN6).....	73
B.5	GPIO (CN7).....	74
	Table B.5 GPIO (CN7).....	74
B.6	LAN1(RJ45) (CN8).....	75
	Table B.6 LAN1(RJ45) (CN8).....	75
B.7	LAN2(RJ45) (CN9).....	75
	Table B.7 LAN2(RJ45) (CN9).....	75
B.8	Compact II without Ejector (CN11).....	76
	Table B.8 Compact II without Ejector (CN11).....	76
B.9	HD & Power LED (CN13).....	77
	Table B.9 HD & Power LED (CN13).....	77
B.10	LVDS Connector (CN14).....	78
	Table B.10 LVDS Connector (CN14).....	78
B.11	Inverter Power (CN15).....	79
	Table B.11 Inverter Power (CN15).....	79
B.12	USB0/1 (CN18).....	79
	Table B.12 USB0/1 (CN18).....	79
B.13	Keyboard/Mouse (CN19).....	80
	Table B.13 Keyboard/Mouse (CN19).....	80
B.14	COM1 (CN21).....	80
	Table B.14 Table B.14: COM1 (CN21).....	80
B.15	RS-422/485 (CN26).....	81
	Table B.15 Table B.15: RS-422/485 (CN26).....	81
B.16	IDE0 (CN27).....	82
	Table B.16 IDE0 (CN27).....	82
B.17	COM2/3/4 & LPT (CN30).....	83
	Table B.17 COM2/3/4 & LPT (CN30).....	83
B.18	USB2/3 & AC97 (Audio I/F) (CN31).....	84
	Table B.18 USB2/3 & AC97 (Audio I/F) (CN31)....	84
Appendix C	System Assignments	86
C.1	System I/O Ports.....	86
	Table C.1 System I/O ports.....	86
C.2	1st MB memory map.....	87
	Table C.2 Table C.2: 1st MB memory map.....	87
C.3	DMA channel assignments.....	87
	Table C.3 DMA channel assignments.....	87
C.4	Interrupt assignments.....	88
	Table C.4 Interrupt assignments.....	88
Appendix D	ATX Power setting	90
D.1	D.1 Introduction.....	90
	Table D.1 Power Connector.....	90
	Figure D.1 ATX power supply diagram.....	91

Appendix E	Mechanical Drawings.....	94
E.1	Mechanical Drawings.....	94
Figure E.1	PCM-4380 Mechanical Drawing (Component Side).....	94
Figure E.2	PCM-4380 Mechanical Drawing (Solder Side).....	94

General Information

This chapter gives background information on the PCM-4380.

Chapter 1 General Information

1.1 Introduction

The PCM-4380 is an EPIC SBC (Single Board Computer) with a high performance and lower power based on Celeron M processors. The PCM-4380, in conjunction with Intel 855GME chipset, supports processors clocked at up to 1GHz, four USB 2.0 compatible ports, 2 PCI Fast or Gigabit Ethernet interface, 2 Channel LVDS interface, and one MIO expansion connector, and can accommodate up to 1GB of ECC DDR RAM memory.

SpeedStep (EIST) technology is another important features for PCM-4380 which can save energy and ensure longer battery life, since it allows the operating system to reduce the processor clock speed when less work is being done.

1.2 Specifications

1.2.1 Standard 4" Biscuit SBC Functions

- **CPU:** Embedded Pentium M Processor supported at Front Side Bus (FSB) 400MHz
- **System Memory:** 1x SODIMM socket, support ECC Double Data Rate (DDR) 128 MB to 1GB, accept 128/256/512/1000 MB DDR200/266 DRAM
- **2nd Cache Memory:** Depend on CPU type from 512 KB to 2 MB
- **System Chipset:** Intel 855GME GMCH/ICH4 chipset
- **BIOS:** AWARD 4Mbit Flash BIOS
- **Watchdog timer:** 255 levels timer interval
- **Expansion Interface:** MIO interface, integrated PCI2.0, USB2.0, SMBus, AC97
- **Battery:** Lithium 3V/196 mAH
- **Power management:** Supports power saving modes including Normal/Standby/Suspend modes. APM 1.2, ACPI compliant
- **Enhanced IDE interface:** One channels supports up to 2 EIDE devices. BIOS auto-detect, PIO Mode 3 or Mode 4, supports UDMA 33 mode
- **Serial ports:** 4 serial RS-232 ports, COM1/3/4: RS-232, COM2: RS-232/422/485

- **Parallel port:** One parallel port, supports SPP/EPP/ECP mode
- **Keyboard/mouse connector:** Supports one standard PC/AT keyboard and a PS/2 mouse
- **Audio:** Support AC97 Audio Interface
- **USB:** 4 USB 2.0 compliant universal serial bus ports
- **Solid State Disk (SSD):** Supports one 50-pin socket for CFC type I/II (option)

1.2.2 VGA/LVDS Interface

- **Chipset:** Intel 855GME Graphic Memory Control Hub (GMCH)
- **Memory Size:** Optimized Shared Memory Architecture, support 64MB frame buffer using system memory
- **Resolution:** CRT display Mode: pixel resolution up to 1600 x 1200 @ 85 Hz and 2048 x 536 @ 75 Hz
- **LVDS Interface:** up to UXGA panel resolution with frequency range from 25MHz to 112MHz
- **Dual Independent Display:** supports CRT+LVDS
- **LVDS:** support 2 channel 36-bits LVDS LCD Panel

1.2.3 Ethernet Interface

- **Chipset supports:**
 - 10/100 Mbps: Intel 82551ER
 - 10/100/1000 Mbps: Intel 82541GI (optional)
- **Interface:** 2 x RJ45, Standard IEEE 802.3u (100Base-T)

1.2.4 Audio Function

- **Chipset:** Intel 82801DB I/O Controller Hub 4 (ICH4) AC97 interface
- **Audio controller:** Support AC97 3D Audio by PCM-4380 daughterboard

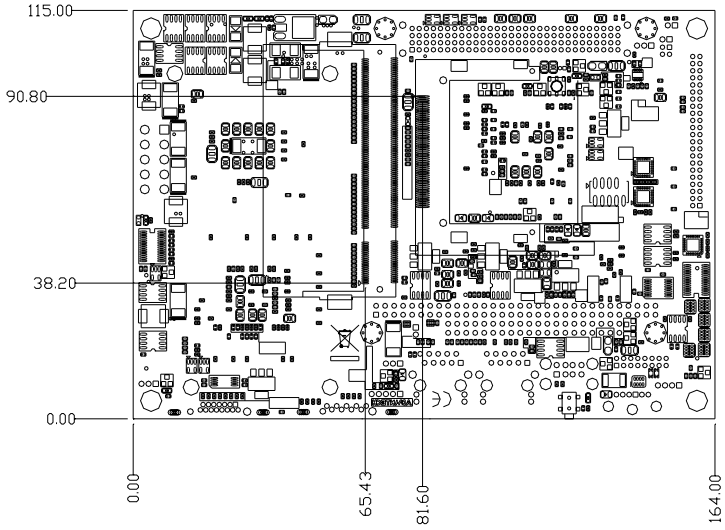

Figure 1.2: Board layout: Dimensions (Solder Side)

Installation

This chapter explains the setup procedures of the PCM-4380 hardware, including instructions on setting jumpers and connecting peripherals, switches and indicators. Be sure to read all safety precautions before you begin the installation procedure.

Sections include:

Chapter 2 Installation

2.1 Jumpers

The PCM-4380 has a number of jumpers that allow you to configure your system to suit your application. The table below lists the functions of the various jumpers.

2.1.1 Jumper Location

Table 2.1: Jumpers

Label	Function
J2	LCD Power
J3	COM2 Setting
J4	PCI VIO Setting

2.1.2 Jumper Settings

Table 2.2: LCD Power (J2)

Setting	Function
1-2	+5V
2-3	+3.3V

Table 2.3: COM2 Setting (J3)

Setting	Function
(1-2)	RS232
(3-4)	RS485
(5-6)	RS422

Table 2.4: PCI-VIO Setting (J4)

Setting	Function
1-2	+5V
2-3	+3.3V

Warning! *To avoid damaging the computer, always turn off the power supply before setting “Clear CMOS.” Before turning on the power supply, set the jumper back to “3.0 V Battery On.”*



This jumper is used to erase CMOS data and reset system BIOS information.

The procedure for clearing CMOS is:

1. Turn off the system.
2. Push clear CMOS bottom and wait for 4 second.
3. Turn on the system. The BIOS is now reset to its default setting

Table 2.5: CMOS clear (S2)

Condition	Result
unpressed*	Normal
pushed	Clear CMOS

* default setting

2.2 Connectors

On-board connectors link the PCM-4380 to external devices such as hard disk drives, a keyboard, or floppy drives. The table below lists the function of each of the board's connectors.

Table 2.6: Connectors

Label	Function
CN1	ATX Power connector
CN3	DDR-SODIMM (RVS) -5.2mm
CN4	Battery connector
CN5	System Fan
CN6	Power Switch
CN7	GPIO connector
CN8	LAN1 (RJ45)
CN9	LAN2 (RJ45)
CN11	Compact II W/Ejector
CN13	HD & Power LED
CN14	LVDS connector
CN15	Inverter Power
CN16	VGA connector
CN18	USB 0/1
CN19	Keyboard/Mouse
CN21	COM1
CN23	USB AC97 (BH 15*2 1.27mm)
CN24	ISA -5V
CN26	RS-422/485
CN27	IDE0
CN28	MIO USB connector
CN30	COM 2/3/4 & LPT
CN31	USB 2/3 & AC97 (Audio I/F)

2.3 Locating Connectors

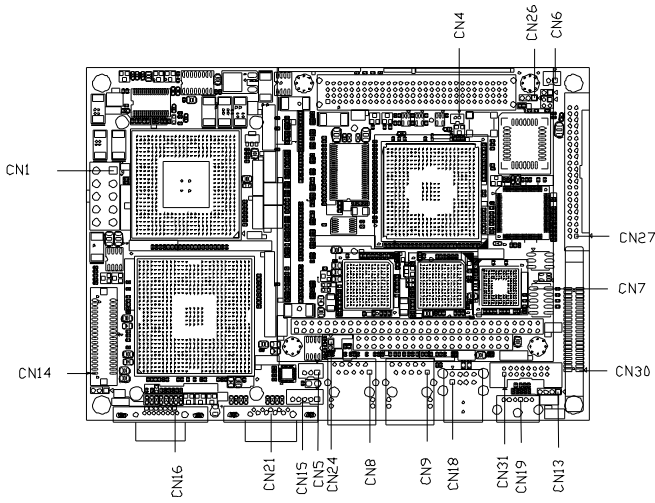

Figure 2.1: Connectors (component side)

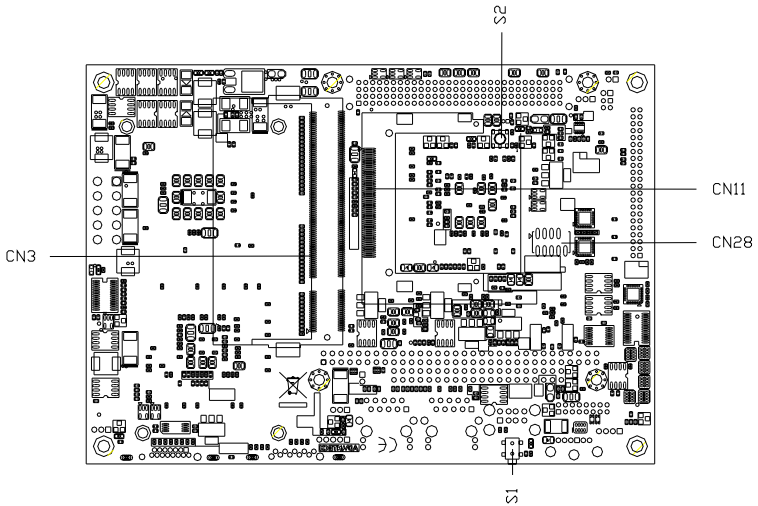
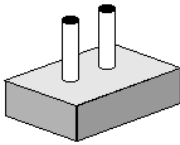

Figure 2.2: Connectors (solder side)

2.4 Setting Jumpers

You may configure your card to match the needs of your application by setting jumpers. A jumper is a metal bridge used to close an electric circuit. It consists of two metal pins and a small metal clip (often protected by a plastic cover) that slides over the pins to connect them. To “close” a jumper, you connect the pins with the clip. To “open” a jumper, you remove the clip. Sometimes a jumper will have three pins, labeled 1, 2 and 3. In this case you would connect either pins 1 and 2, or 2 and 3.



open

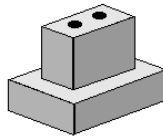

closed

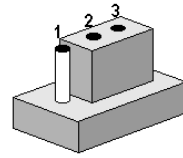

closed 2-3

The jumper settings are schematically depicted in this manual as follows.

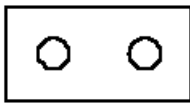

open



closed

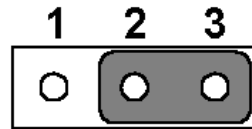

closed 2-3

A pair of needle-nose pliers may be helpful when working with jumpers. If you have any doubts about the best hardware configuration for your application, contact your local distributor or sales representative before you make any changes.

Generally, you simply need a standard cable to make most connections.

2.5 Installing SO-DIMM

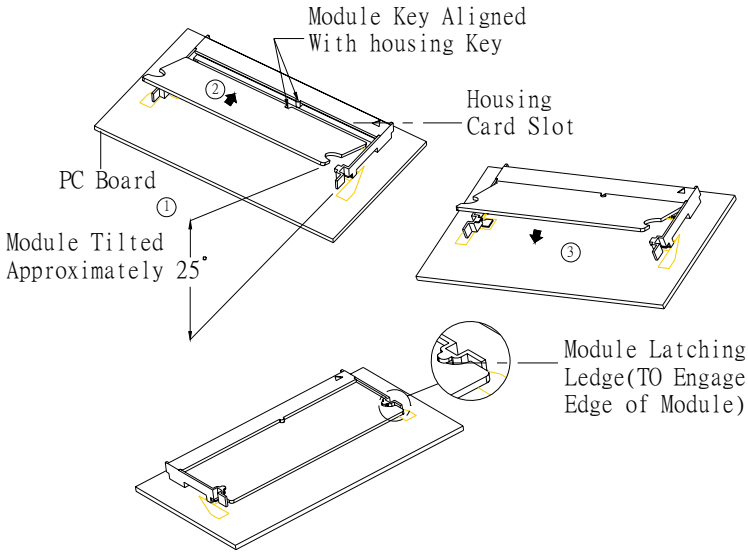

The procedures for installing SODIMMs are described below. Please follow these steps carefully. You can install SDRAM memory modules using 200-pin SODIMMs (Small Outline Dual In-line Memory Modules).

1. Ensure that all power supplies to the system are switched off.
2. Tilt the SODIMM card approximately 25° above the board, and move it in the direction of the housing card slot. Make sure that the key in the module and the key in the housing are aligned.
3. Push the module into the socket until the module bottoms. There should be a slight insertion force to engage the module into the contacts.

2.6 IDE, CDROM hard drive connector (CN27)

The board provides 1 IDE channels which you can attach up to two Enhanced Integrated Device Electronics hard disk drives or CDROM to the board's internal controller. Its IDE controller uses a PCI interface. This advanced IDE controller supports faster data transfer, PIO mode 3, mode 4 and up to UDMA/33.

2.6.1 Connecting the hard drive

Connecting drives is done in a daisy-chain fashion. This package includes One 44PIN IDE cable that can connect to 1.8" and 2.5" drives.

1. Connect one end of the cable to Hard Drive connector. Make sure that the red (or blue) wire corresponds to pin 1 on the connector, which is labeled on the board (on the right side).
2. Plug the other end of the cable into the Enhanced IDE hard drive, with pin 1 on the cable corresponding to pin 1 on the hard drive. (See your hard drive's documentation for the location of the connector.)

If desired, connect a second drive as described above.

Unlike floppy drives, IDE hard drives can connect to either end of the cable. If you install two drives, you will need to set one as the master and one as the slave by using jumpers on the drives. If you install only one drive, set it as the master.

2.7 Solid State Disk

The board provides a CompactFlash™ card type I/II socket.

2.7.1 CompactFlash (CN11)

The CompactFlash card shares a secondary IDE channel which can be enabled/disabled via the BIOS settings.

2.8 Parallel port connector (CN30)

Normally, the parallel port is used to connect the card to a printer. The board includes a multi-mode (ECP/EPP/SPP) parallel port accessed via CN30 and a 50-pin flat-cable connector. You will need an adapter cable if you use a traditional DB-25 connector. The adapter cable has a 50-pin connector on one end, and a DB-25 connector on the other.

The parallel port is designated as LPT1, and can be disabled in the system BIOS setup.

The parallel port interrupt channel is designated to be IRQ7.

You can select ECP/EPP DMA channel via BIOS setup.

2.9 Keyboard and PS/2 mouse connector (CN9)

The board provides a keyboard connector that supports both a keyboard and a PS/2 style mouse. In most cases, especially in embedded applications, a keyboard is not used. If the keyboard is not present, the standard PC/AT BIOS will report an error or fail during power-on self-test (POST) after a reset. The PCM-4380's BIOS standard setup menu allows you to select "All, But Keyboard" under the "Halt On" selection. This allows no-keyboard operation in embedded system applications, without the system halting under POST.

2.10 Power & HDD LED Connector (CN13)

Next, you may want to install external switches to monitor and control the board. These features are optional: install them only if you need them. The Power & HDD LED connector is 6-pin Wafer box connector. It provides connections for a power and hard disk access indicator.

2.10.1 Power & HDD LED Connector(CN10)

The HDD LED indicator for hard disk access is an active low signal (24 mA sink rate). Power supply activity LED indicator.

2.10.2 Power Reset button (S1)

Momentarily pressing the reset button will activate a reset. The switch should be rated for 10 mA, 5 V.

2.11 Power connectors (CN1)

2.11.1 Main power connector, +3.3V, +5 V, +12 V (CN3)

Supplies main power to the PCM-4380 (+5 V), and to devices that require +12 V.

2.11.2 Fan power supply connector (CN5)

Provides +5V power supply to CPU cooling fan.

2.12 Audio interfaces (CN31)

2.12.1 Audio connector (CN31)

The board provides all major audio signals and it can be optional with Line-in/Line-out/Speaker-out function by PCM-4380 daughterboard.

2.13 COM port connector (CN21,CN30)

The PCM-4380 provides 4 serial ports (COM1/3/4: RS-232; COM2: RS-232/422/485) in one DB-9 connector (COM1) and one 50-pin dual-inline, male header. It provides connections for serial devices (a mouse, etc.) or a communication network. You can find the pin assignments for the COM port connector in Appendix C.

2.13.1 COM2 RS-232/422/485 setting (J3)

COM2 can be configured to operate in RS-232, RS-422, or RS-485 mode. This is done via J3.

Table 2.7: J3: COM2 RS-232/422/485 select

Setting	Function
J3 (1-2)(open)	RS-232
J3 (1-2)(open)	RS-422
J3 (1-2)(open)	RS-485

2.14 VGA/LCD/LVDS interface connections

The board's PCI SVGA interface can drive conventional CRT displays and is capable of driving a wide range of flat panel displays, including passive LCD and active LCD displays. The board has two connectors to support these displays: one for standard CRT VGA monitors, one for flat panel displays, and one for LVDS type LCD panels.

2.14.1 CRT display connector (CN16)

The CRT display connector is a 15-pin D-SUB connector used for conventional CRT displays.

2.14.2 LVDS LCD panel connector (CN14)

The board supports 2 channel 36-bit LVDS LCD panel displays. Users can connect to an 36-bit LVDS LCD on it.

2.15 Ethernet configuration

The board is equipped with 2 high performance 32-bit PCI-bus Ethernet interface which is fully compliant with IEEE 802.3U 10/100Mbps and IEEE 802.3 z/ab 1000BASE-T standards. It is supported by all major network operating systems.

2.15.1 100Base-T/1000Base-T connector (CN8, CN9)

100Base-T connections are made via the on-board RJ-45 connector

2.15.2 Network boot (Depends on Ethernet Controller Gigabit Ethernet only)

The Network Boot feature can be utilized by incorporating the Boot ROM image files for the appropriate network operating system. The Boot ROM BIOS files are included in the system BIOS, which is on the utility CD disc.

2.16 Watchdog timer configuration

An on-board watchdog timer reduces the chance of disruptions while board working improperly. This is an invaluable protective device for standalone or unmanned applications. Setup involves one jumper and running the control software (refer to Appendix A).

2.17 USB connectors (CN31,CN18, CN28)

The board provides up to four USB (Universal Serial Bus) ports. This gives complete Plug and Play, and hot attach/detach for up to 127 external devices. The USB interfaces comply with USB specification Rev. 2.0 which supports 480Mbps transfer rate, and are fuse protected.

The USB interface is accessed through one 8 x 2-pin flat-cable connectors, CN31 (USB0, 1). You will need an adapter cable if you use a standard USB connector. The adapter cable has a 8 x 2-pin connector on one end and a USB connector on the other.

Also, There's one USB2.0 jack on CN9 for convenient connecting USB device.

The USB interfaces can be disable in the system BIOS setup.

2.18 GPIO (General Purpose Input Output) (CN7)

The board supports 8-bit GPIO through GPIO connector. The 8 digital in and out-puts can be programmed to read or control devices, with input or out-put defined. The default setting is 4 bits input and 4 bits output.

CHAPTER

3

Chipset Software Installation Utility

Chapter 3 Chipset Software Installation Utility

3.1 Before you begin

To facilitate the installation of the enhanced display device drivers and utility software, you should read the instructions in this chapter carefully before you attempt installation. The device drivers for the PCM-4380 board are located on the software installation CD. The auto-run function of the driver CD will guide and link you to the utilities and device drivers under a Windows system. The Intel® Chipset Software Installation Utility is not required on any systems running Windows 2000. Updates are provided via Service Packs from Microsoft*.

Note *The files on the software installation CD are compressed. Do not attempt to install the drivers by copying the files manually. You must use the supplied SETUP program to install the drivers.*

Before you begin, it is important to note that most display drivers need to have the relevant software application already installed in the system prior to installing the enhanced display drivers. In addition, many of the installation procedures assume that you are familiar with both the relevant software applications and operating system commands. Review the relevant operating system commands and the pertinent sections of your application software's user manual before performing the installation.

3.2 Introduction

The Intel® Chipset Software Installation (CSI) utility installs to the target system the Windows INF files that outline to the operating system how the chipset components will be configured. This is needed for the proper functioning of the following features:

- Core PCI and ISA PnP services.
- USB 1.1 support (USB 2.0 driver needs to be installed separately)
- Identification of Intel® chipset components in the Device Manager.
- Integrates superior video features. These include filtered sealing of 720 pixel DVD content, and MPEG-2 motion compensation for software DVD

Note This utility for Windows 2000 or XP, and it has to be installed before installing all other drivers.

3.3 Installing the CSI Utility

1. Insert the driver CD into your system's CD-ROM drive. In a few seconds, the cd main menu appears. Move to "\\PCM-4380\1_FIRST_INST". And click "INFINST_ENU" icon.

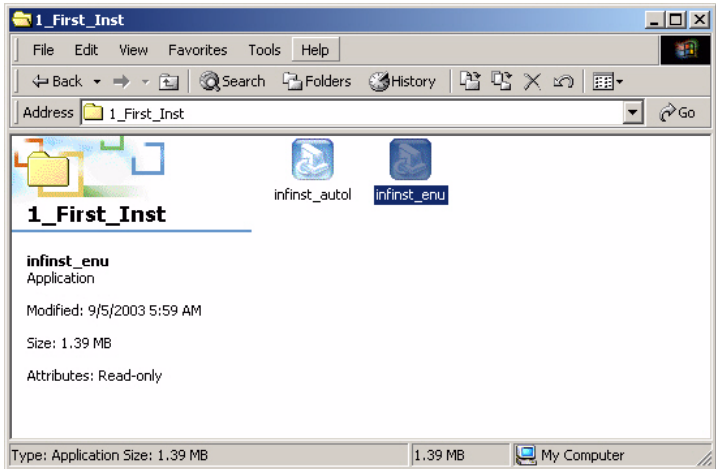

2. Click "Next" when you see the following message.

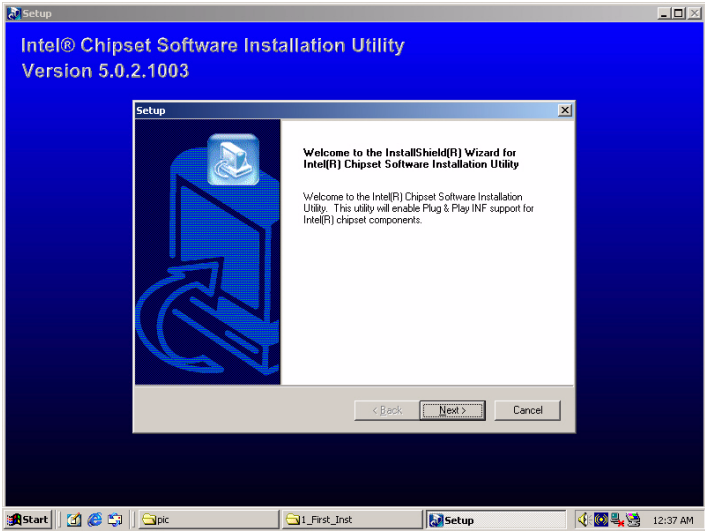

3. Click "Yes" when you see the following message.

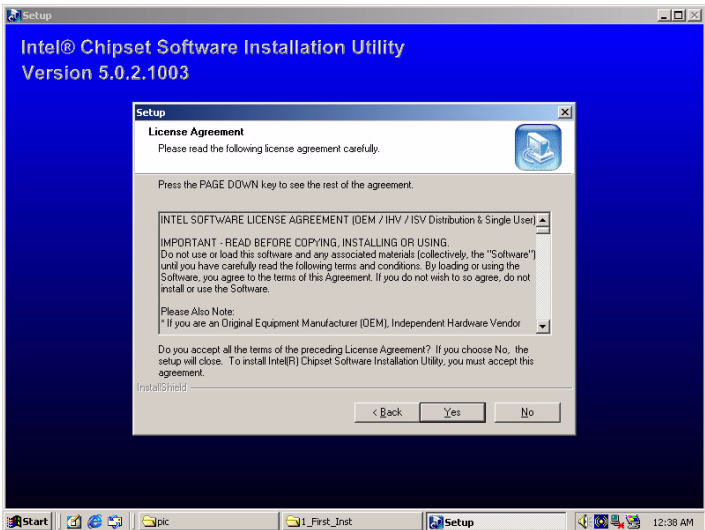

4. Click "Next" when you see the following message.

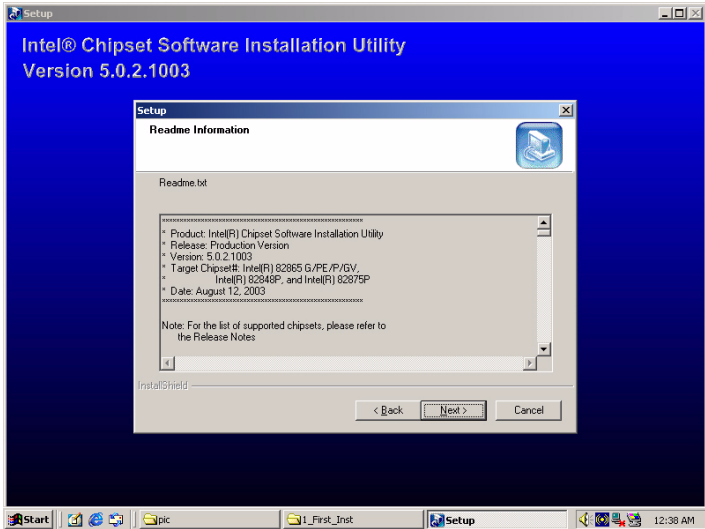

5. When the following message appears, click "Finish" to complete the installation and restart Windows.

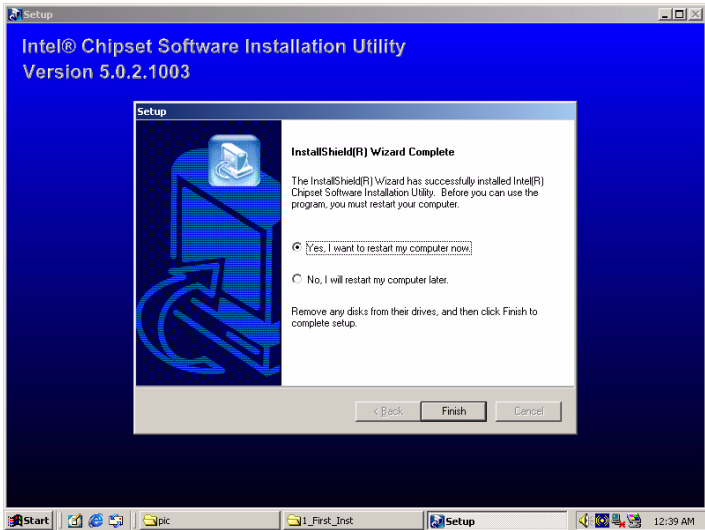

CHAPTER

4

Award BIOS Setup

Chapter 4 Award BIOS Setup

4.1 Introduction

Award's BIOS ROM has a built-in setup program that allows users to modify the basic system configuration. This type of information is stored in battery-backed memory (CMOS RAM) so that it retains the setup information when the power is turned off.

4.1.1 CMOS RAM Auto-backup and Restore

The CMOS RAM is powered by an onboard button cell battery. When you finish BIOS setup, the data in CMOS RAM will be automatically backed up to Flash ROM. If operation in harsh industrial environment cause a soft error, BIOS will recheck the data in CMOS RAM and automatically restore the original data in Flash ROM to CMOS RAM for booting.

Note *If you intend to change the CMOS setting without restoring the previous backup, you have to click on "DEL" within two seconds of the "CMOS checksum error..." display screen message appearing. Then enter the "Setup" screen to modify the data. If the "CMOS checksum error..." message appears again and again, please check to see if you need to replace the battery in your system.*

4.2 Entering Setup

Turn on the computer and check for the “patch code”. If there is a number assigned to the patch code, it means that the BIOS supports your CPU.

If there is no number assigned to the patch code, please contact Advantech’s applications engineer to obtain an up-to-date patch code file. This will ensure that your CPU’s system status is valid. After ensuring that you have a number assigned to the patch code, press to allow you to enter the setup.

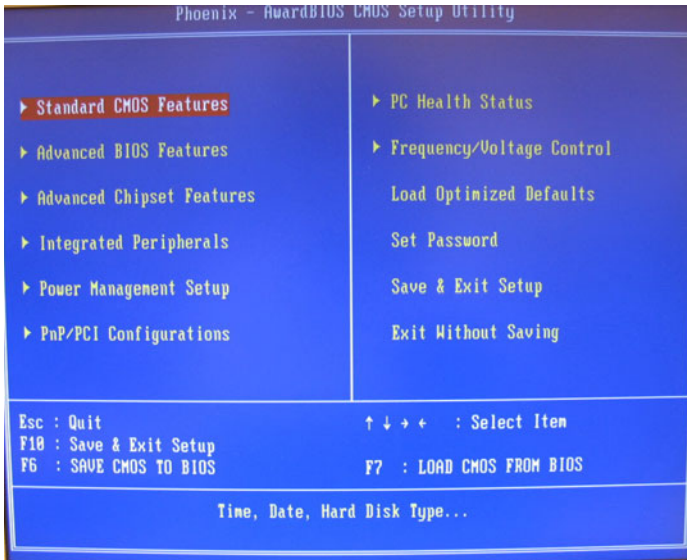

Figure 4.1: Award BIOS Setup initial screen

4.3 Standard CMOS Setup

Choose the “Standard CMOS Features” option from the “Initial Setup Screen” menu, and the screen below will be displayed. This menu allows users to configure system components such as date, time, hard disk drive, floppy drive, display, and memory.

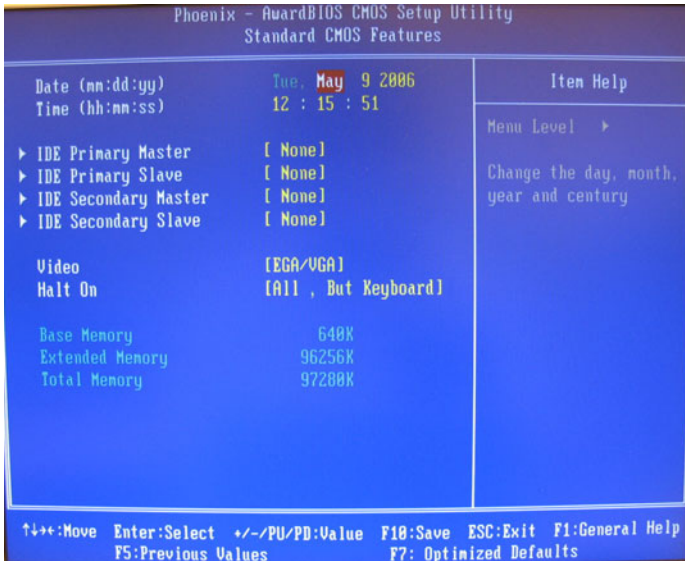

Figure 4.2: Standard CMOS features screen

4.4 Advanced BIOS Features

The “Advanced BIOS Features” screen appears when choosing the “Advanced BIOS Features” item from the “Initial Setup Screen” menu. It allows the user to configure the PCM-4380 according to his particular requirements. Below are some major items that are provided in the Advanced BIOS Features screen. A quick booting function is provided for your convenience. Simply enable the Quick Booting item to save yourself valuable time.

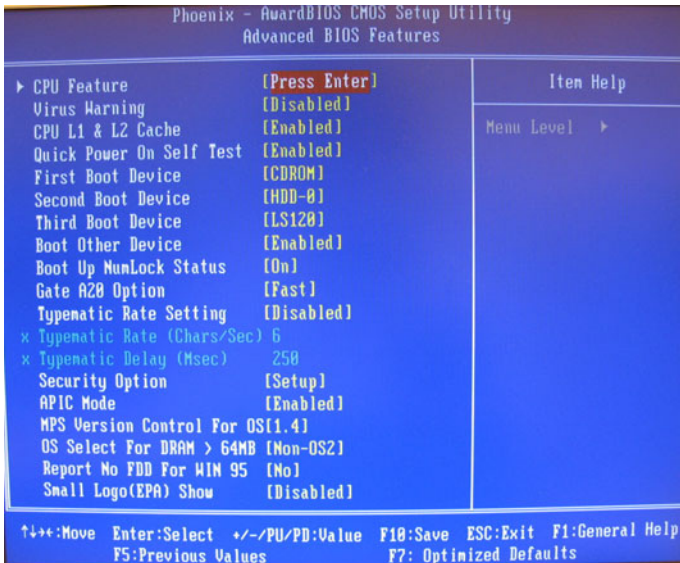

Figure 4.3: Advanced BIOS features screen

4.4.1 Virus Warning

If enabled, a warning message and alarm beep activates if someone attempts to write here. The commands are “Enabled” or “Disabled.”

4.4.2 L1 & L2 Cache

Enabling this feature speeds up memory access. The commands are “Enabled” or “Disabled.”

4.4.3 Quick Power On Self Test

This option speeds up the Power-On Self Test (POST) conducted as soon as the computer is turned on. When enabled, BIOS shortens or skips some of the items during the test. When disabled, the computer conducts normal POST procedures.

4.4.4 First/Second/Third/Other Boot Device

The BIOS tries to load the OS with the devices in the sequence selected. Choices are: LS/ZIP, HDD, CDROM, LAN, Disabled.

4.4.5 Boot Up NumLock Status

This feature selects the “power on” state for NumLock. The commands are “Enabled” or “Disabled.”

4.4.6 Gate A20 Option

- **Normal:** A pin in keyboard controller controls GateA20
- **Fast (Default):** Chipset controls GateA20.

4.4.7 Typematic Rate Setting

The typematic rate is the rate key strokes repeat as determined by the keyboard controller. The commands are “Enabled” or “Disabled.” Enabling allows the typematic rate and delay to be selected.

4.4.8 Typematic Rate (Chars/Sec)

BIOS accepts the following input values (characters/second) for typematic rate: 6, 8, 10, 12, 15, 20, 24, 30.

4.4.9 Typematic Delay (msec)

Typematic delay is the time interval between the appearance of two consecutive characters, when holding down a key. The input values for this category are: 250, 500, 750, 1000 (msec).

4.4.10 Security Option

This setting determines whether the system will boot up if the password is denied. Access to Setup is always limited.

- **System:** The system will not boot, and access to Setup will be denied if the correct password is not entered at the prompt.
- **Setup:** The system will boot, but access to Setup will be denied if the correct password is not entered at the prompt.

Note To disable security, select "PASSWORD SETTING" in the main menu. At this point, you will be asked to enter a password. Simply press <Enter> to disable security. When security is disabled, the system will boot, and you can enter Setup freely.

4.4.11 APIC Mode

This setting allows selecting an OS with greater than 64MB of RAM. Commands are "Non-OS2" or "OS2."

4.4.12 MPS Version Control For OS

This reports if an FDD is available for Windows 95. The commands are "Yes" or "No."

4.5 Integrated Peripherals

4.5.1 IDE Master/Slave PIO/UDMA Mode,

IDE Primary (Secondary) Master/Slave PIO/UDMA Mode (Auto) Each channel (Primary and Secondary) has both a master and a slave, making four IDE devices possible. Because each IDE device may have a different Mode timing (0, 1, 2, 3, 4), it is necessary for these to be independent. The default setting "Auto" will allow auto detection to ensure optimal performance.

4.5.2 On-Chip Secondary PCI IDE

If you enable IDE HDD Block Mode, the enhanced IDE driver will be enabled. Leave IDE HDD Block Mode on the default setting.

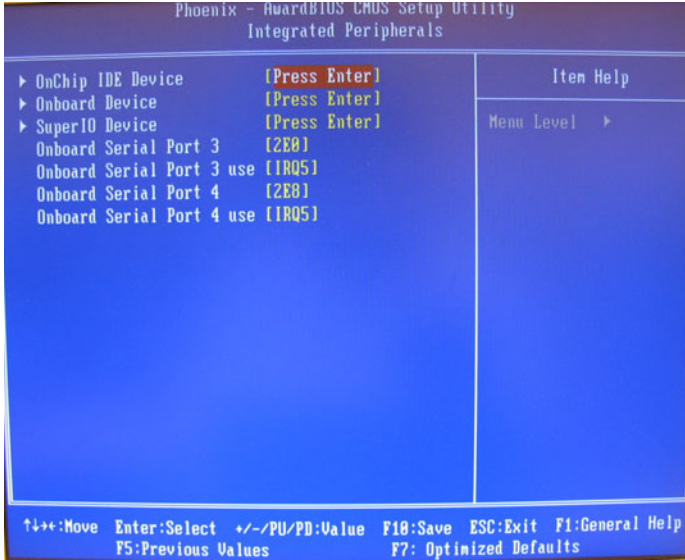

Figure 4.4: Integrated peripherals

4.5.3 USB Controller

Select Enabled if your system contains a Universal Serial Bus (USB) controller and you have USB peripherals. The choices: Enabled, Disabled.

4.5.4 USB Keyboard/Mouse Support

Select Enabled if user plan to use an USB keyboard. The choice: Enabled, Disable.

4.5.5 AC97 Audio

Select Disable if you do not want to use AC-97 audio. Option is Auto, Disable.

4.5.6 Init Display First

This item allows you to choose which one to activate first, PCI Slot or onchip VGA. The choices: PCI Slot, Onboard.

4.5.7 IDE HDD Block Mode

You can enable the Primary IDE channel and/or the Secondary IDE channel. Any channel not enabled is disabled. This field is for systems with only SCSI drives.

4.5.8 Onboard Serial Port

For settings reference the Appendix for the serial resource allocation, and Disabled for the on-board serial connector.

4.5.9 Onboard Parallel Port

This field sets the address of the on-board parallel port connector. You can select either 3BCH/IRQ7, 378H/IRQ7, 278H/IRQ5 or Disabled. If you install an I/O card with a parallel port, make sure there is no conflict in the address assignments. The CPU card can support up to three parallel ports, as long as there are no conflicts for each port.

4.5.10 Parallel Port Mode

This field allows you to set the operation mode of the parallel port. The setting “Normal” allows normal speed operation, but in one direction only. “EPP” allows bidirectional parallel port operation at maximum speed. “ECP” allows the parallel port to operate in bi-directional mode and at a speed faster than the maximum data transfer rate. “ECP + EPP” allows normal speed operation in a two-way mode.

4.5.11 EPP Mode Select

This field allows you to select EPP port type 1.7 or 1.9. The choices: EPP1.7, 1.9.

4.5.12 ECP Mode Use DMA

This selection is available only if you select “ECP” or “ECP + EPP” in the Parallel Port Mode field. In ECP Mode Use DMA, you can select DMA channel 1, DMA channel 3, or Disable. Leave this field on the default setting.

4.6 Power Management Setup

The power management setup controls the CPU card's "green" features to save power. The following screen shows the manufacturer's defaults:

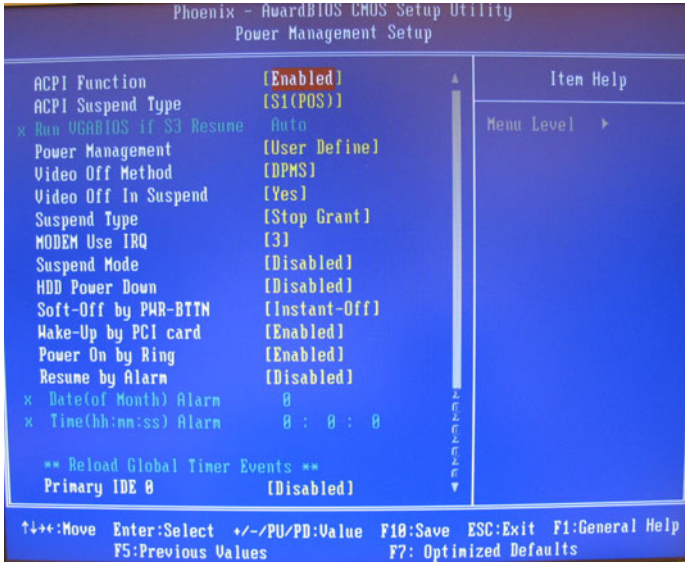

Figure 4.5: Power management setup screen

4.6.1 Power-Supply Type

ATX power supply

4.6.2 ACPI function

The choice: Enabled, Disabled.

4.6.3 Power Management

This category allows you to select the type (or degree) of power saving and is directly related to the following modes:

1. HDD Power Down
2. Suspend Mode

There are four selections for Power Management, three of which have fixed mode settings.

Min. Power Saving	Minimum power management., Suspend Mode = 1 hr., and HDD Power Down = 15 min.
Max. Power Saving	Maximum power management., Suspend Mode = 1 min., and HDD Power Down = 1 min.
User Defined (Default)	Allows you to set each mode individually. When not disabled, each of the ranges are from 1 min. to 1 hr. except for HDD Power Down which ranges from 1 min. to 15 min. and disable.

4.6.4 Video Off In Suspend

When system is in suspend, video will turn off.

4.6.5 Modem Use IRQ

This determines the IRQ in which the MODEM can use. The choices: 3, 4, 5, 7, 9, 10, 11, NA.

4.6.6 HDD Power Down

You can choose to turn the HDD off after one of the time intervals listed, or when the system is in “suspend” mode. If the HDD is in a power saving mode, any access to it will wake it up.

4.6.7 Soft-Off by PWR-BTTN

If you choose “Instant-Off”, then pushing the ATX soft power switch button once will switch the system to “system off” power mode. You can choose “Delay 4 sec.” If you do, then pushing the button for more than 4 seconds will turn off the system, whereas pushing the button momentarily (for less than 4 seconds) will switch the system to “suspend” mode.

4.6.8 PowerOn By LAN(GigaLAN option)

This item allows you to wake up the system via LAN from the remote-host. The choices: Enabled, Disabled.

4.6.9 PowerOn By Ring

When Enabled, an input signal on the serial Ring Indicator (RI) line (in other words, an incoming call on the modem) awakens the system from a soft off state. The choices: Enabled, Disabled.

4.6.10 PowerOn By Alarm

When Enabled, you can set the date and time at which the RTC (realtime clock) alarm awakens the system from Suspend mode. The choices: Enabled, Disabled.

4.6.11 Primary IDE 0 (1) and Secondary IDE 0 (1)

When Enabled, the system will resume from suspend mode if Primary IDE 0 (1) or Secondary IDE 0 (1) is active. The choice: Enabled, Disabled.

4.6.12 FDD, COM, LPT PORT

When Enabled, the system will resume from suspend mode if FDD, COMport, or LPT port is active. The choice: Enabled, Disabled.

4.6.13 PCI PIRQ [A-D]#

When Enabled, the system will resume from suspend mode if interrupt occurs. The choice: Enabled, Disabled.

4.7 PnP/PCI Configurations

4.7.1 PnP OS Installed

Select Yes if you are using a plug and play capable operating system. Select No if you need the BIOS to configure non-boot device.

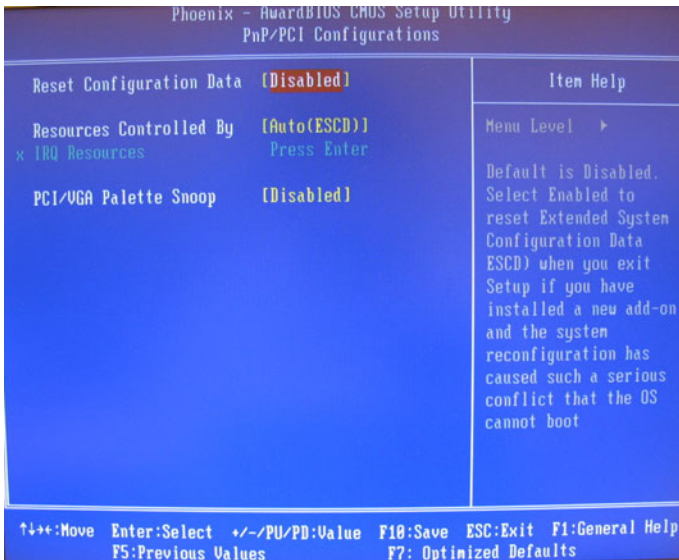

Figure 4.6: PnP/PCI configurations screen

4.7.2 Reset Configuration Data

Default is Disable. Select Enable to reset Extended System Configuration Data (ESCD) if you have installed a new add-on and system reconfiguration has caused such a conflict that OS cannot boot.

4.7.3 Resources controlled by:

The commands here are “Auto” or “Manual.” Choosing “manual” requires you to choose resources from each following sub-menu. “Auto” automatically configures all of the boot and Plug and Play devices but you must be using Windows 95 or above.

4.7.4 PCI/VGA Palette Snoop

This is left at “Disabled.”

4.8 Password Setting

To change the password:

1. Choose the “Set Password” option from the “Initial Setup Screen” menu and press <Enter>.

The screen will display the following message:

Please Enter Your Password

2. Press <Enter>.
3. If the CMOS is good or if this option has been used to change the default password, the user is asked for the password stored in the CMOS.

The screen will display the following message:

Please Confirm Your Password

4. Enter the current password and press <Enter>.
5. After pressing <Enter> (ROM password) or the current password (user-defined), you can change the password stored in the CMOS. The password must be no longer than eight (8) characters.

Remember, to enable the password setting feature, you must first select either “Setup” or “System” from the “Advanced BIOS Features” menu.

4.9 Save & Exit Setup

If you select this and press <Enter>, the values entered in the setup utilities will be recorded in the CMOS memory of the chipset. The microprocessor will check this every time you turn your system on and compare this to what it finds as it checks the system. This record is required for the system to operate.

4.10 Exit Without Saving

Selecting this option and pressing <Enter> lets you exit the setup program without recording any new values or changing old ones.

CHAPTER 5

PCI SVGA/LCD Setup

This chapter details the software configuration information. It shows you how to configure the card to match your application requirements.

Chapter 5 PCI SVGA/LCD Setup

5.1 Introduction

The board has an onboard Intel 855GME chipset for its AGP/SVGA controller. It supports LVDS LCD displays and conventional analog CRT monitors with 64MB frame buffer shared with system memory. The VGA controller can drive CRT displays with resolutions up to 1600 x 1200 @ 85 Hz and 2048 x 536 @ 75 Hz and support 2 channel LVDS display mode up to UXGA panel resolution with frequency range from 25 MHz to 112 MHz.

5.1.1 CMOS setting for panel type

The PCM-4380 system BIOS and custom drivers are located in a 512 Kbyte, Flash ROM device, designated U29. A single Flash chip holds the system BIOS, VGA BIOS and network Boot ROM image. The display can be configured via CMOS settings. This method minimized the number of chips and different type of LCD panels, please choose "panel type" from the "integrated peripherals" menu in CMOS setting.

5.1.2 Display type

The PCM-4380 can be set in one of three configurations: on a CRT, on a flat panel display, or on both dual independent display. The system is initially set to dual display mode. If you want to enable the CRT display only or the flat panel display only, please contact Intel Corporation or our sales representative for detailed information.

5.1.3 Dual Independent Display

The PCM-4380F uses a Intel 855GME controller that is capable of providing multiple views and simultaneous display with mixed video and graphics on a flat panel and CRT.

To set up dual display under Windows 2000/XP follow these steps:

1. Select “Windows 2000”, “Control panel”, "Setting", "Advanced", "Graphics Properties" "Device".

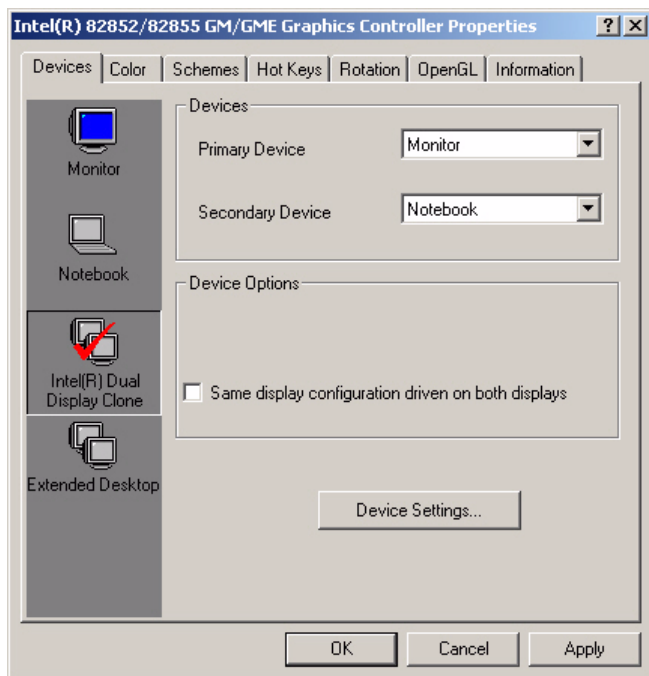

2. Select “1” for current display, or “2” for second display.

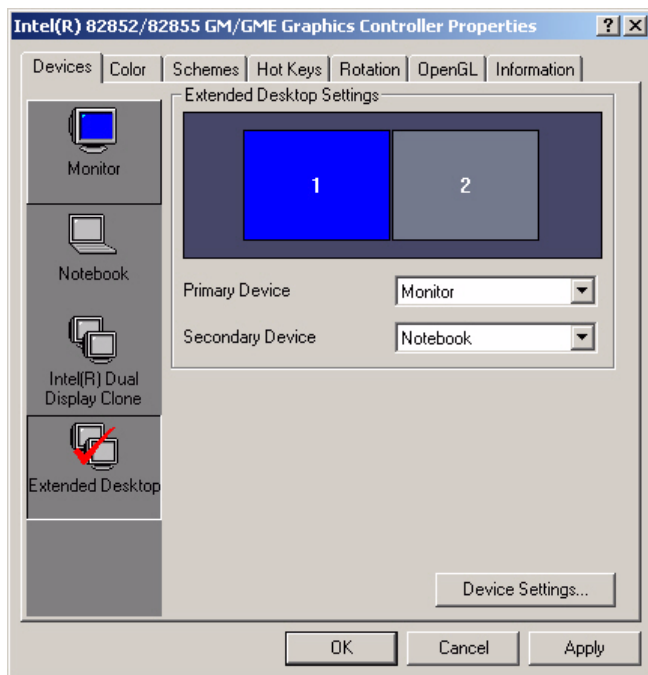

3. Enable “Extend my Windows desktop onto this monitor”.
4. Click “OK”.

5.2 Connections to Two Standard LCDs

The following tables illustrate typical LCD connection pinouts for the PCM-4380.

5.2.1 LG LM 150x06 (1024x768 LVDS LCD)

* LCD connector type: HRS DF 19K-20P-1H or compatible

Table 5.1: Connections to LCD/Flat Panel (CN1)

LCD Connector		Flat Panel Connector	
Unipac-UB104S01		DF-13 40P	
Pin	Function	Pin	Function
1	VCC	1	+5V
2	VCC	2	+5V
3	GND	3	GND
4	GND	4	GND
5	RxIN0-	7	LVDS_YAM0R
6	RxIN0+	9	LVDS_YAP0R
7	GND	11	GND
8	RxIN1-	13	LVDS_YAM1R
9	RxIN1+	15	LVDS_YAP1R
10	GND	17	GND
11	RxIN2-	19	LVDS_YAM2R
12	RxIN2+	21	LVDS_YAP2R
13	GND	23	GND
14	CKIN-	25	LVDS_CLKAMR
15	CKIN+	27	LVDS_CLKAPR
16	GND	29	GND
17	NC		NC
18	NC		NC
19	GND	33	GND
20	GND	34	GND

5.2.2 AU M170EG01 (1024x768 LVDS LCD @ 36bit)

Table 5.2: Connections to AU M170EG01 (CNI)

AU M170EG01		PCM-4380 CN1	
Pin	Function	Pin	Function
1	RxOIN0-	7	LVDS_YAM0
2	RxOIN0+	9	LVDS_YAP0
3	RxOIN1-	13	LVDS_YAM1
4	RxOIN1+	15	LVDS_YAP1
5	RxOIN2-	19	LVDS_YAM2
6	RxOIN2+	21	LVDS_YAP2
7	VSS	11	GND
8	RxOCLKIN-	25	LVDS_CLKAM
9	RxOCLKIN+	27	LVDS_CLKAP
10	RxOIN3-	35	LVDS_YAM3
11	RxOIN3+	37	LVDS_YAP3
12	RxEIN0-	8	LVDS_YBM0
13	RxEIN0+	10	LVDS_YBP0
14	VSS	17	GND
15	RxEIN1-	14	LVDS_YBM1
16	RxEIN1+	16	LVDS_YBP1
17	VSS	23	GND
18	RxEIN2-	20	LVDS_YBM2
19	RxEIN2+	22	LVDS_YBP2
20	RxECLKIN-	26	LVDS_CLKBM
21	RxECLKIN+	28	LVDS_CLKBP
22	RxEIN3-	36	LVDS_YBM3
23	RxEIN3+	38	LVDS_YBP3
24	VSS	29	GND
25	VSS	30	GND
26	NC		NC
27	VSS	33	GND
28	VCC	1	LCD VDD (+5V)
29	VCC	2	LCD VDD (+5V)
30	VCC		

5.3 Installation of the SVGA Driver

Complete the following steps to install the SVGA driver. Follow the procedures in the flow chart that apply to the operating system that you are using within your PCM-4380.

- Note*
- 1. The windows illustrations in this chapter are intended as examples only. Please follow the listed steps, and pay attention to the instructions which appear on your screen.*
 - 2. For convenience, the CD-ROM drive is designated as "D" throughout this chapter.*

5.3.1 Installation of Windows 2000

1. Find Win2000 VGA driver from CD at the directory of PCM-4380 CD, VGA\win2k_xp1332.

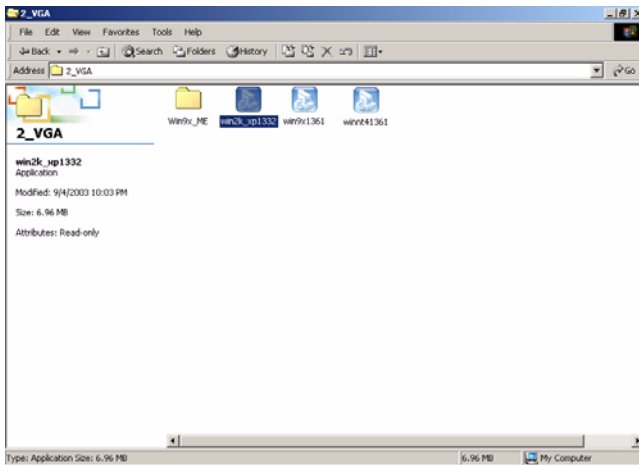

2. Double click "setup" and "next" into setup wizard.

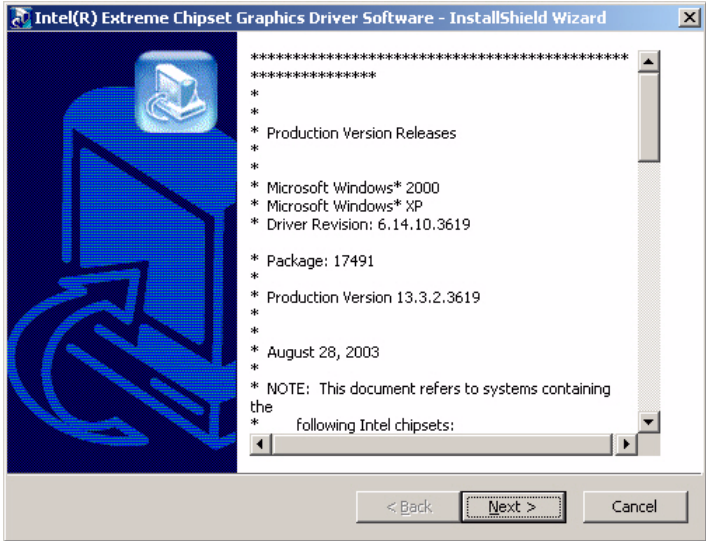

3. Click "Next" to install Intel Extreme Graphics Driver.

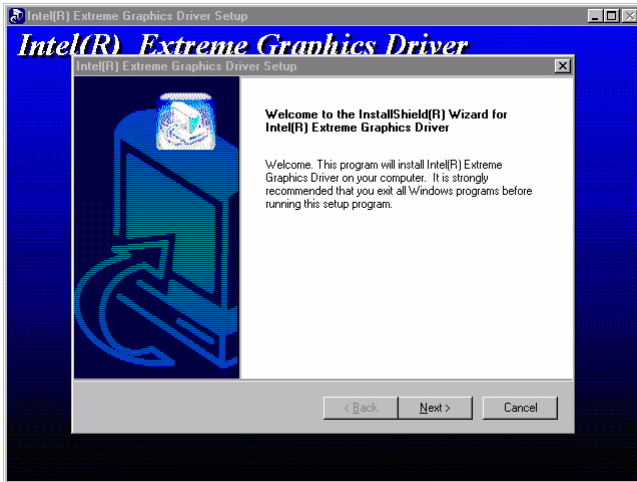

4. Click “Yes” to continue setup.

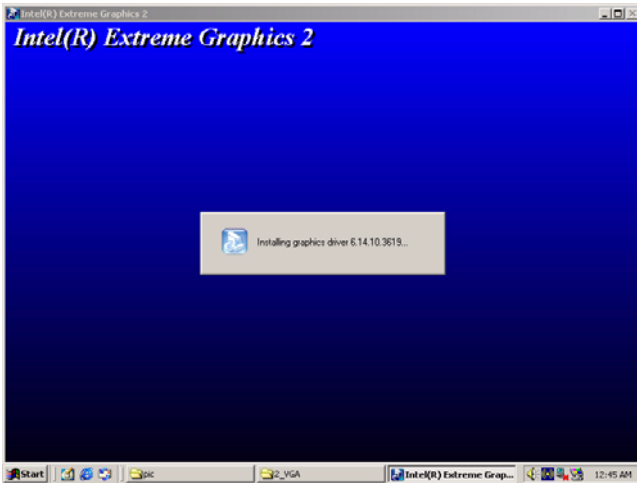
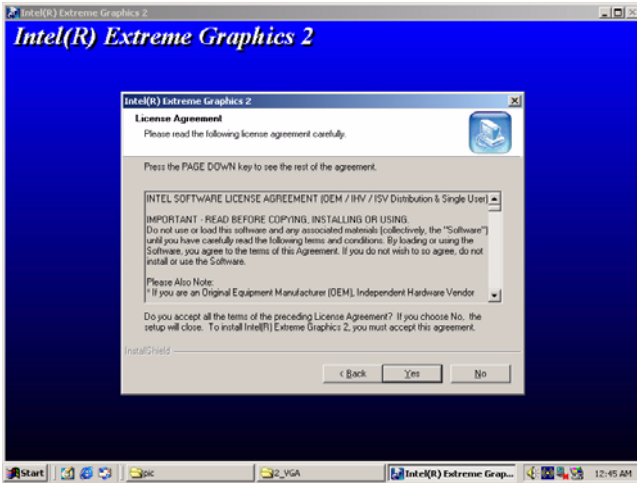

- Restart computer when installation finished.

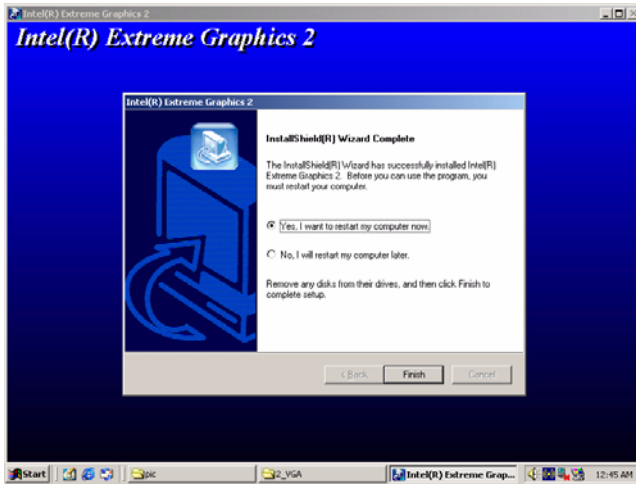

5.4 Further Information

For further information about the AGP/VGA installation in your PCM-4380, including driver updates, troubleshooting guides and FAQ lists, visit the following web resources:

Intel website: www.intel.com
Advantech websites: www.advantech.com
www.advantech.com.tw

Audio Setup

The PCM-4380 is equipped with an audio interface that records and plays back CD-quality audio. This chapter provides instructions for installing the software drivers included on the audio driver diskettes.

Chapter 6 Audio Setup

6.1 Introduction

The PCM-4380's audio interface provides high-quality stereo sound and FM music synthesis (ESFM) by using the Intel ICH4 audio controller. The audio interface can record, compress, and play back voice, sound, and music with built-in mixer control and PCM-4380 daughterboard can support this feature.

6.2 Driver installation

6.2.1 Before you begin

Please read the instructions in this chapter carefully before you attempt installation. The audio drivers for the PCM-4380 board are located on the audio driver CD. Run the supplied SETUP program to install the drivers; don't copy the files manually.

Note *The files on the software installation diskette are compressed. Do not attempt to install the drivers by copying the files manually. You must use the supplied SETUP program to install the drivers.*

6.2.2 Windows 98 drivers

1. Find Win2000/XP Audio driver folder from CD at the directory of PCM-4380 CD, click "setup" to start the installation process.

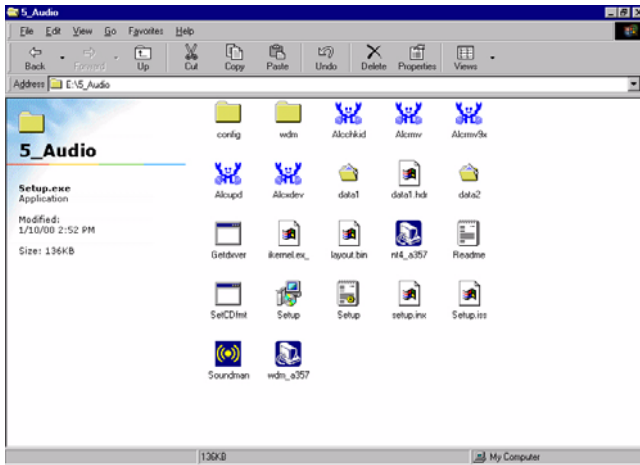

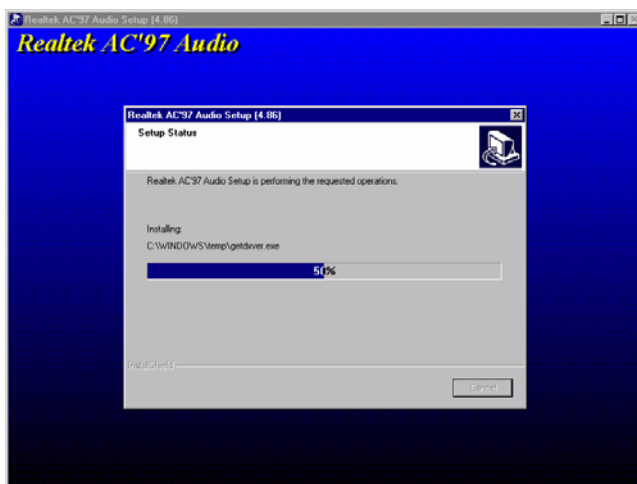

2. Click "yes" to reboot your computer.

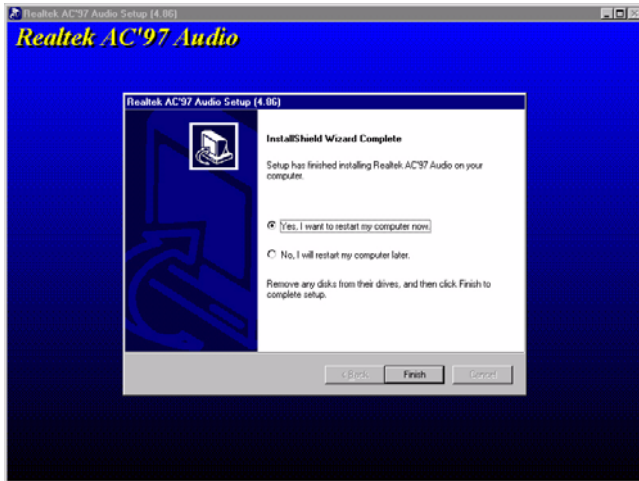

CHAPTER 7

Ethernet Interface

This chapter provides information on Ethernet configuration.

Chapter 7 Ethernet Interface

7.1 Introduction

The PCM-4380 is equipped with a high performance 32-bit Ethernet chipset which is fully compliant with IEEE 802.3 100 Mbps CSMA/CD standards. It is supported by major network operating systems. It is also both 1000Base-T and 100Base-T compatible. The network boot feature can be utilized by incorporating the boot ROM image files for the appropriate network operating system. The boot ROM BIOS files are combined with system BIOS, which can be enabled/disabled in the BIOS setup.

7.2 Installation of Ethernet driver

Before installing the Ethernet driver, note the procedures below. You must know which operating system you are using in your PCM-4380 Series, and then refer to the corresponding installation flow chart. Then just follow the steps described in the flow chart. You will quickly and successfully complete the installation, even if you are not familiar with instructions for MS-DOS or Windows.

7.2.1 Installation for Windows 2000

1. Select "Start", "Settings", "Control Panel".

Note *The windows illustrations in this chapter are examples only. Follow the steps and pay attention to the instructions which appear on your screen.*

2. Double click "Network".

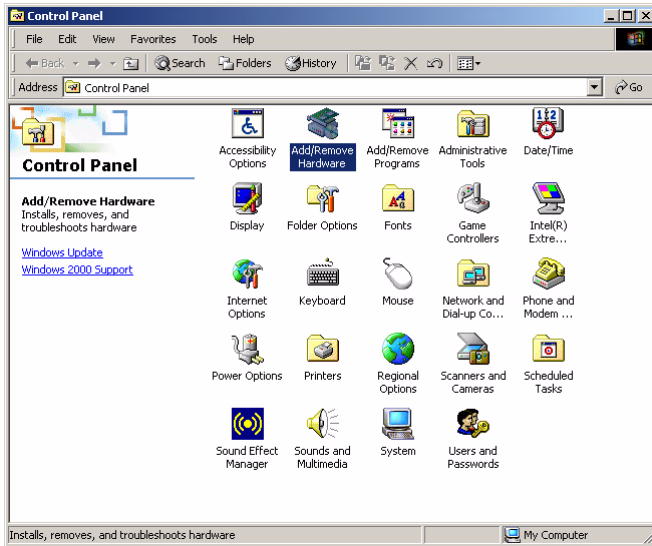

3. Click “Add new hardware wizard” and prepare to install network function.

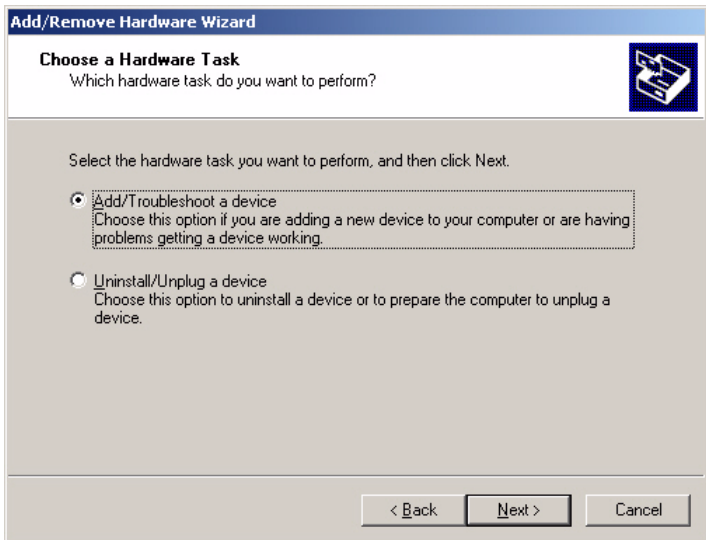

4. Choose Hardware Device “Ethernet Controller”.

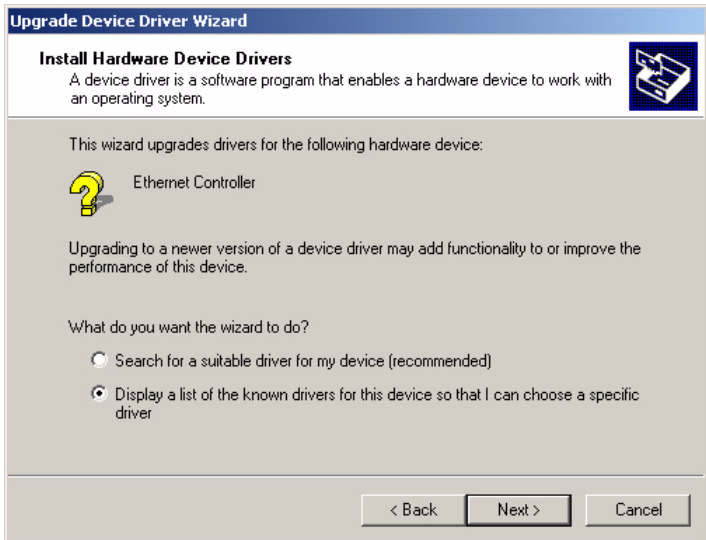
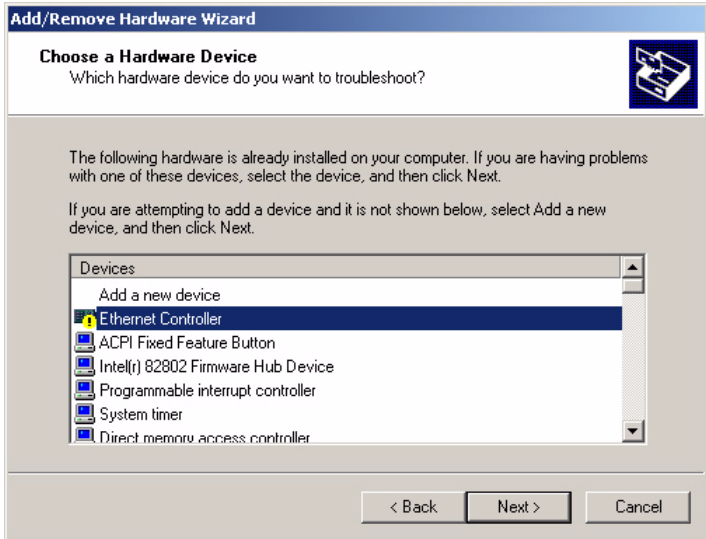

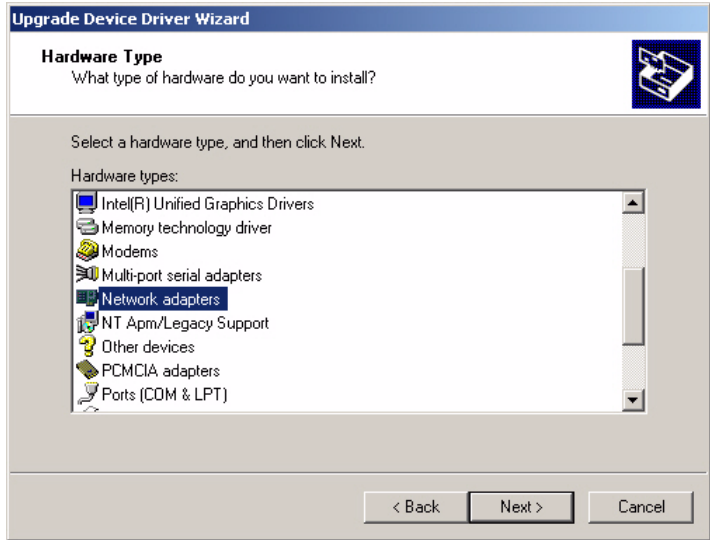

5. Insert the CD into D: drive.
6. Fill in the Find the LAN chipset folder at the directory of PCM-4380 win2000 folder from CD ROM drive.
7. Click "OK".

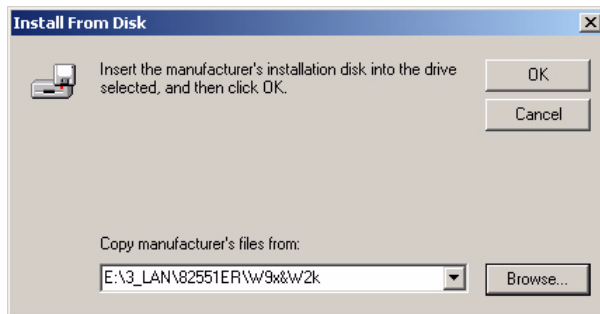

8. Choose the "Intel GD82559ER PCI Adapter" item.

9. Click “Next”.

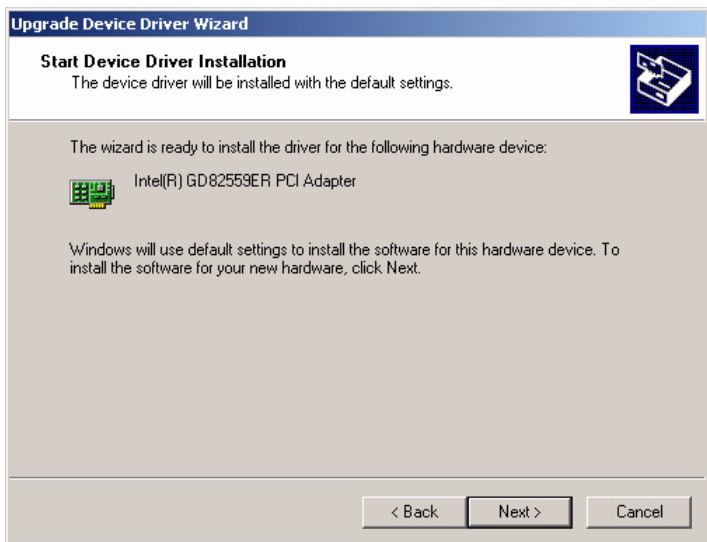
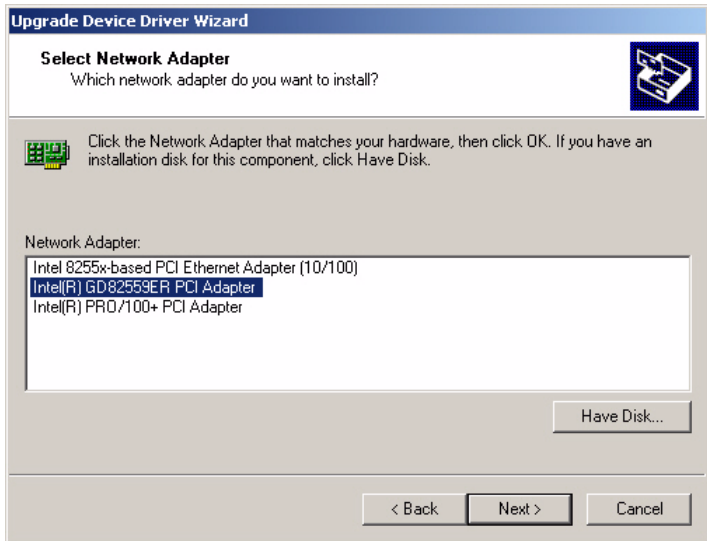

10. Make sure the configurations of relative items are set correctly.

11. Click “OK”.



7.3 Further information

Intel website:	www.intel.com
Advantech websites:	www.advantech.com
	www.advantech.com.tw

Installing MIO Modules

This appendix gives instructions for installing MIO modules.

Chapter 8 Installing MIO Modules

8.1 MIO Introduction

8.1.1 M2M concept

Due to many devices needed to connect to IP & Mobile networks, Advantech has done a lot research and development to fulfill the concept of Machine to Machine or Machine to Mobile communication in Industrial application fields.

8.1.2 Easy to have wireless technology with your embedded motherboard

Advantech MIO-series products provide Wireless/Bluetooth/GSM/GPRS modules through onboard USB interface. Also, there are more advanced applications like GPS, Zigbee, and RFID that are going to be introduced in a near future.

8.1.3 The best board combination for a system



Figure 8.1: PCM-4380 + MIO 2320

8.2 Optional Modules

8.2.1 MIO-2310 Wireless module

- Support 802.11b/g
- Data rate up to 54Mbps
- RoHS compliance

8.2.2 MIO-2320 GSM/GPRS module

- Support Quad-band: GSM 850/900/1800/1900MHz
- Support Multi-slot Class 12
- RoHS compliance

8.2.3 MIO-3121 Mini-PCI to 4 COMs module

- Compliant with PCI Specification, revision 2.3
- Support Four 16C950 High performance UART channels
- Support 32-bit, 33MHz MiniPCI interface, fully compliant to PCI Local Bus specification 3.0
- RoHS compliance

8.2.4 MIO-3140 Mini-PCI to 2 SATA module

- Compliant with PCI Specification, revision 2.3
- Supports 66MHz PCI with 32-bit data
- Supports two independent Serial ATA channels
- RoHS compliance

8.2.5 MIO-3150 Mini-PCI to Video Capture module

- PCI 2.2 Compliant
- All-standards TV decoder: NTSC, PAL and SECAM
- Output in YUV and RGB
- RoHS compliance

Programming the GPIO and Watchdog Timer

The PCM-4380 is equipped with a watchdog timer that resets the CPU or generates an interrupt if processing comes to a standstill for any reason. This feature ensures system reliability in industrial standalone or unmanned environments.

Appendix A Programming the GPIO and Watchdog Timer

A.1 Supported GPIO Register

Bellow are detailed description of the GPIO addresses for SCH3114 and programming sample.

A.1.1 GPIO Registers

The GPIO control register define in runtime register. The runtime register offset is “800h”.

A.1.2 GPIO Example program-1

Example:

```
Program GPIO_52
mov dx,800h+ 41h ;The GPIO_52 register offset is 41h base
                  ;on runtime register offset.
mov al,10000000b ;Program the GPIO_52 is output, no
                  ;invert; output type is push pull.
out dx,al        ;bit 0:in/out =1 input, =0 output
                  ;bit 1:polarity =1 invert,=0 no invert
                  ;bit 2:Alternate function select
                  ;1=RXD2
                  ;0=GPIO
                  ;bit 6~3 : Reserved
                  ;bit7: Output type select
                  ;1=Open Drain
                  ;0=Push pull
```

Program WatchDog for SCH3114

Example:

```
mov dx,800h + 47h ;Program GPIO as WDT
mov al,0ch
out dx,al
mov dx,800h + 65h ;WDT Time-out value units select
mov al,080h      ;Bit7:=0 minutes , =1 Seconds
out dx,al
```

```

mov dx,800h + 66h    ;WDT timer time-out value
mov al,01h          ;0x00 Time-out disabled
                    ;0x01 Time-out=1 minute(second)
                    ;....
                    ;0xFF Time-out =255 minutes(seconds)

out dx,al
mov dx,800h + 68h    ;Enable WDT function.
mov al,01h
out dx,al

```

Pin Assignments

This appendix contains information of a detailed or specialized nature. It includes:

Appendix B Pin Assignments

B.1 ATX Power connector (CN1)

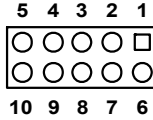

Table B.1: ATX Power connector (CN1)

Part Number 1655000042

Pin	Signal
1	PS_ON
2	GND
3	GND
4	VCC_12V
5	VCC3
6	VCC_SB
7	VCC
8	VCC
9	V-12V
10	GND

B.2 Battery connector (CN4)



Table B.2: Battery connector (CN4)

Part Number 1655902032

Description Wafer box 2P 180D (M)

Pin	Signal
1	VBAT
2	GND

B.3 System FAN (CN5)

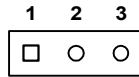

Table B.3: System FAN (CN5)

Part Number 1655303020

Description Wafer box 2.0mm 3P 180D w/LOCK

Pin	Signal
1	FAN_IO
2	+12V
3	GND

B.4 Power Switch (CN6)



Table B.4: Power Switch (CN6)

Part Number 1655302020

Description Wafer box 2P 180D 2.0mm male w/LOCK

Pin	Signal
1	FP_PSIN
2	GND

B.5 GPIO (CN7)

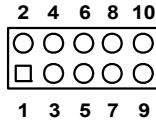

Table B.5: GPIO (CN7)

Part Number 1653005261

Description Pin header SMD 5*2P 180D(M) 2.0mm

Pin	Signal
1	+5V
2	GPIO4
3	GPIO0
4	GPIO5
5	GPIO1
6	GPIO6
7	GPIO2
8	GPIO7
9	GPIO3
10	GND

B.6 LAN1(RJ45) (CN8)

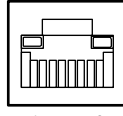

Table B.6: LAN1(RJ45) (CN8)

Part Number 1652000147

Pin	Signal
1	LAN_TX+
2	LAN_TX-
3	LAN_RX+
7	LAN_MID2+
8	LAN_MID2-
4	LAN_RX-
9	LAN_MID3+
10	LAN_MID3-
5	LAN-LED1
6	LAN-LED2

B.7 LAN2(RJ45) (CN9)

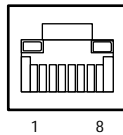

Table B.7: LAN2(RJ45) (CN9)

Part Number 1652000147

Pin	Signal
1	LAN_TX+
2	LAN_TX-
3	LAN_RX+
4	LAN_MID0+
5	LAN_MID0-
6	LAN_RX-
7	LAN_MID+
8	LAN_MID1-

B.8 Compact II without Ejector (CN11)

Table B.8: Compact II without Ejector (CN11)

Part Number 1653025215

Description Header for CF Type 11 50P 90D(M)Standoff 2.0mm

Pin	Signal	Pin	Signal
1	GND	2	IDE1_D3
3	IDE1_D4	4	IDE1_D5
5	IDE1_D6	6	IDE1_D7
7	IDE1_CS#1	8	GND
9	GND	10	GND
11	GND	12	GND
13	+5V	14	GND
15	GND	16	GND
17	GND	18	IDE1_A2
19	IDE1_A1	20	IDE1_A0
21	IDE1_D0	22	IDE1_D1
23	IDE1_D2	24	NC
25	GND	26	CF_CD#1
27	IDE1_D11	28	IDE1_D12
29	IDE1_D13	30	IDE1_D14
31	IDE1_D15	32	IDE1_CS#3
33	NC	34	IDE1_IOR#
35	IDE1_IOW#	36	IDE1_WE#
37	IDE1_IRQ15	38	+5V
39	CF_CSEL#	40	NC
41	IDE1_RST#	42	IDE1_IORDY
43	IDE1_DREQ	44	IDE1_DACK#
45	CF_ASP#	46	NC
47	IDE1_D8	48	IDE1_D9
49	IDE1_D10	50	GND

B.9 HD & Power LED (CN13)

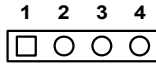

Table B.9: HD & Power LED (CN13)

Part Number 1653004101

Description PIN HEADER 4*1P 180D(M) SQUARE 2.0mm

Pin	Signal
1	+5V
2	GND
3	+5V
4	HD_LED

B.10 LVDS Connector (CN14)

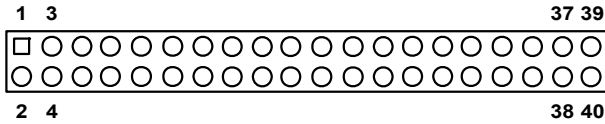

Table B.10: LVDS Connector (CN14)

Part Number 1653920200

Description *CONN. DF13-40DP-1.25V

Pin	Signal	Pin	Signal
1	+5V/+3.3V	2	+5V/+3.3V
3	GND	4	GND
5	+5V/+3.3V	6	+5V/+3.3V
7	LVDS0_D0-	8	LVDS1_D0-
9	LVDS0_D0+	10	LVDS1_D0+
11	GND	12	GND
13	LVDS0_D1-	14	LVDS1_D1-
15	LVDS0_D1+	16	LVDS1_D1+
17	GND	18	GND
19	LVDS0_D2-	20	LVDS1_D2-
21	LVDS0_D2+	22	LVDS1_D2+
23	GND	24	GND
25	LVDS0_CLK-	26	LVDS1_CLK-
27	LVDS0_CLK+	28	LVDS1_CLK+
29	GND	30	GND
31	LVDS0_SC_DDC	32	LVDS0_SD_DDC
33	GND	34	GND
35	LVDS0_D3-	36	LVDS1_D3-
37	LVDS0_D3+	38	LVDS1_D3+
39	NC	40	NC

B.11 Inverter Power (CN15)

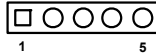

Table B.11: Inverter Power (CN15)

Part Number 1655305020

Description Wafer box 2.0mm 5P 180D male w/LOCK

Pin	Signal
1	LVDS0_V12
2	GND
3	LVDS0_ENABKL
4	LVDS0_VBR
5	LVDS0_V5

B.12 USB0/1 (CN18)

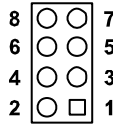

Table B.12: USB0/1 (CN18)

Part Number 1654908100

Description USB Connector dual port 8P 90D(M) Black PC99

Pin	Signal	Pin	Signal
1	+5V	2	USB0_P-
3	USB0_P+	4	GND
5	+5V	6	USB1_P-
7	USB1_P+	8	GND

B.13 Keyboard/Mouse (CN19)

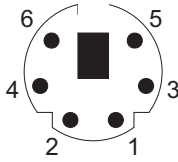

Table B.13: Keyboard/Mouse (CN19)

Part Number 1654606203

Description Mini din 6P 90D(F) D Short body W/Shielding w/pb

Pin	Signal
1	KB_DAT
2	MS_DAT
3	GND
4	+5V
5	KB_CLK
6	MS_CLK

B.14 COM1 (CN21)

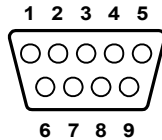

Table B.14: Table B.14: COM1 (CN21)

Part Number 1654000056

Description D-SUB CON.9P 90D(M)

Pin	Signal	Pin	Signal
1	DCD#	2	RXD#
3	TXD#	4	DTR#
5	GND	6	DSR#
7	RTS#	8	CTS#
9	RI#		

B.15 RS-422/485 (CN26)

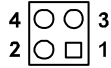

Table B.15: Table B.15: RS-422/485 (CN26)

Part Number 1653004101

Description PIN HEADER 4*1P 180D(M) SQUARE 2.0mm

Pin	Signal
1	TXD 485-/422 TX-
2	TXD 485+/422 TX+
3	RXD 485-/422 RXD-
4	RXD 485+/422 RXD+

B.16 IDE0 (CN27)

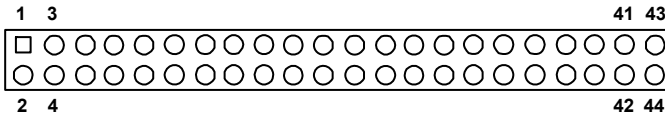

Table B.16: IDE0 (CN27)

Part Number 165322020B

Description BOX HEADER 20*2P 180D(M) 2.54mm Blue

Pin	Signal	Pin	Signal
1	IDE0_RST#	2	GND
3	IDE0_D7	4	IDE0_D8
5	IDE0_D6	6	IDE0_D9
7	IDE0_D5	8	IDE0_D10
9	IDE0_D4	10	IDE0_D11
11	IDE0_D3	12	IDE0_D12
13	IDE0_D2	14	IDE0_D13
15	IDE0_D1	16	IDE0_D14
17	IDE0_D0	18	IDE0_D15
19	GND	20	NC
21	IDE0_DREQ	22	GND
23	IDE0_IOW	24	GND
25	IDE0_IOR	26	GND
27	IDE0_IORDY	28	IDE0_CSEL
29	IDE0_DACK#	30	GND
31	IDE0_IRQ14	32	NC
33	IDE0_A1	34	IDE0_D66DET#
35	IDE0_A0	36	IDE0_A2
37	IDE0_CS#0	38	IDE0_CS#1
39	IDE0_ASP#	40	GND
41	+5V	42	+5V
43	GND	44	NC

B.17 COM2/3/4 & LPT (CN30)

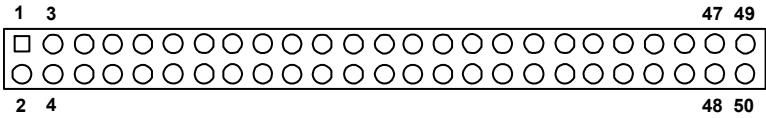

Table B.17: COM2/3/4 & LPT (CN30)

Part Number 1653000141

Pin	Signal	Pin	Signal
1	COM2_DCD#	2	COM2_DSR#
3	COM2_RXD	4	COM2_RTS#
5	COM2_TXD	6	COM2_CTS#
7	COM2_DTR#	8	COM2_RI#
9	GND	10	COM3_DSR#
11	COM3_DCD#	12	COM3_RTS#
13	COM3_RXD	14	COM3_CTS#
15	COM3_TXD	16	COM3_RI#
17	COM3_DTR#	18	COM4_DSR#
19	GND	20	COM4_RTS#
21	COM4_DCD#	22	COM4_CTS#
23	COM4_RXD	24	COM4_RI#
25	COM4_TXD	26	GND
27	COM4_DTR#		
29	GND		
31	LPT_STBR#	32	LPT_AFD#
33	LPT_PRD0	34	LPT_ERR#
35	LPT_PRD1	36	LPT_INIT#
37	LPT_PRD2	38	LPT_SLIN#
39	LPT_PRD3	40	LPT_PRD0
41	LPT_PRD5	42	LPT_PRD6
43	LPT_PRD7	44	LPT_ACK#
45	LPT_BUSY	46	LPT_PE
47	LPT_SLCT	48	GND
49	GND	50	GND

B.18 USB2/3 & AC97 (Audio I/F) (CN31)

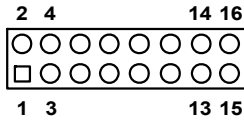

Table B.18: USB2/3 & AC97 (Audio I/F) (CN31)

Part Number 1653005260

Description PIN HEADER 8*2P 180D(M) 2.0mm SMD IDIOT-PROOF

Pin	Signal	Pin	Signal
1	AC_SYNC	2	+5V
3	AC_SDIN0	4	AC_RST
5	AC_SDOUT	6	AC_BITCLK
7	+5V	8	+5V
9	USB2_P-	10	USB3_P-
11	USB2_P+	12	USB3_P+
13	GND	14	GND
15	GND	16	N/A

APPENDIX

C

System Assignments

This appendix contains information of a detailed nature.

Appendix C System Assignments

C.1 System I/O Ports

Table C.1: System I/O ports

Addr. range (Hex)	Device
000-01F	DMA controller
020-021	Interrupt controller 1, master
040-05F	8254 timer
060-06F	8042 (keyboard controller)
070-07F	Real-time clock, non-maskable interrupt (NMI) mask
080-09F	DMA page register
0A0-0BF	Interrupt controller 2
0C0-0DF	DMA controller
0F0	Clear math co-processor
0F1	Reset math co-processor
0F8-0FF	Math co-processor
1F0-1F8	Fixed disk
200-207	Reserved (Game I/O)
278-27F	Reserved (Parallel port 2,LTP3)
2E8-2EF	Reserved (Series port 4)
2F8-2FF	Serial port 2
300-31F	Prototype card
360-36F	Reserved
378-37F	Parallel printer port 1 (LPT 2)
380-38F	SDLC, bisynchronous 2
3A0-3AF	Bisynchronous 1
3B0-3BF	Monochrome display and printer adapter (LPT1)
3C0-3CF	Reserved
3D0-3DF	Color/graphics monitor adapter
3E8-3EF	Reserved (Series port 3)
3F0-3F7	Diskette controller
3F8-3FF	Serial port 1

* PNP audio I/O map range from 220 ~ 250H (16 bytes)

MPU-401 select from 300 ~ 330H (2 bytes)

C.2 1st MB memory map

Table C.2: Table C.2: 1st MB memory map

Addr. range (Hex)	Device
F0000h - FFFFFh	System ROM
*CC000h - EFFFFh	Unused (reserved for Ethernet ROM)
C0000h - CBFFFh	Expansion ROM (for VGA BIOS)
B8000h - BFFFFh	CGA/EGA/VGA text
B0000h - B7FFFh	Unused
A0000h - AFFFFh	EGA/VGA graphics
00000h - 9FFFFh	Base memory

* If Ethernet boot ROM is disabled (Ethernet ROM occupies about 16 KB)

* E0000 - EFFFF is reserved for BIOS POST

C.3 DMA channel assignments

Table C.3: DMA channel assignments

Channel	Function
0	Available
1	Available (audio)
2	Floppy disk (8-bit transfer)
3	Available (parallel port)
4	Cascade for DMA controller 1
5	Available
6	Available
7	Available

* Audio DMA select 1, 3, or 5

** Parallel port DMA select 1 (LPT2) or 3 (LPT1)

C.4 Interrupt assignments

Table C.4: Interrupt assignments

Interrupt#	Interrupt source
IRQ 0	Interval timer
IRQ 1	Keyboard
IRQ 2	Interrupt from controller 2 (cascade)
IRQ 3	COM2
IRQ 4	COM1
IRQ 5	Reserved (COM4)
IRQ 6	FDD
IRQ 7	LPT1
IRQ 8	RTC
IRQ 9	Reserved (audio)
IRQ 10	Reserved (COM3)
IRQ 11	Reserved for watchdog timer
IRQ 12	PS/2 mouse
IRQ 13	INT from co-processor
IRQ 14	Primary IDE

* Ethernet interface IRQ select: 9, 11

* PNP audio IRQ select: 9, 11

* PNP USB IRQ select: 9, 11

* PNP ACPI IRQ select: 9, 11

ATX Power setting

This appendix contains information of a detailed nature.

Appendix D ATX Power setting

D.1 D.1 Introduction

PCM-4380 supports ATX power mode to boot up system. ATX should connect standby power and power supply on# signal to turn on main power supply.

The power connector table & Power supply diagram tables are as bellow:

Table D.1: Power Connector

Pin	Name	Signal Type	Signal Level
1	PS_ON	IN	+5V
2	GND	+5V	
3	GND	GND	
4	VCC_12V	PWR	+12V
5	VCC3	PWR	+3.3V
6	VCC_SB	PWR	+5V
7	VCC	PWR	+5V
8	VCC	PWR	+5V
9	V_12V	PWR	-12V
10	GND	+5V	

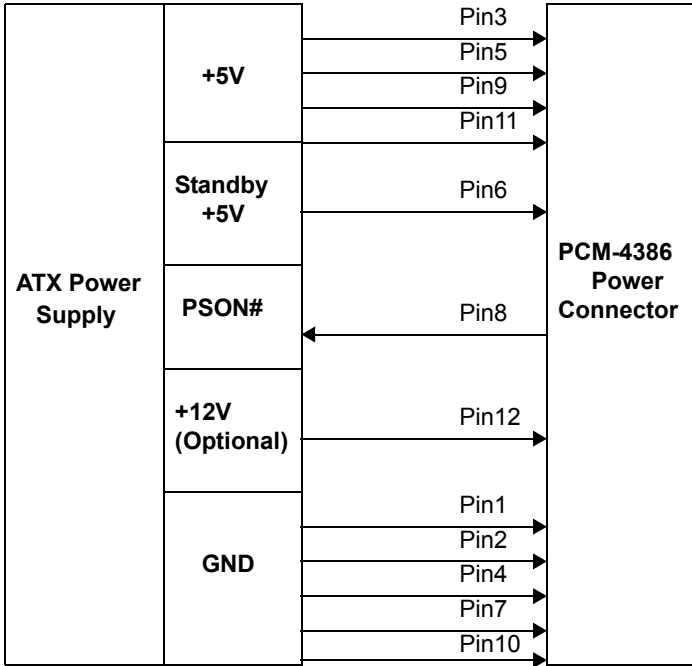

Figure D.1: ATX power supply diagram

APPENDIX

E

Mechanical Drawings

Appendix E Mechanical Drawings

E.1 Mechanical Drawings

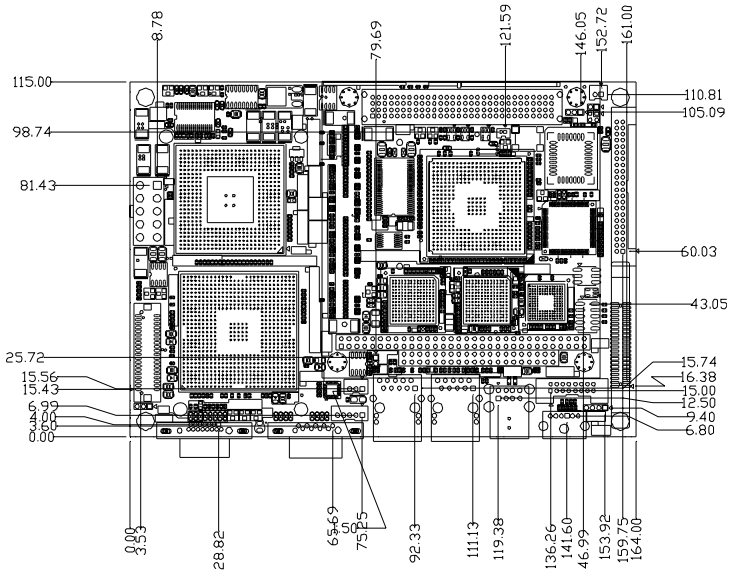

Figure E.1: PCM-4380 Mechanical Drawing (Component Side)

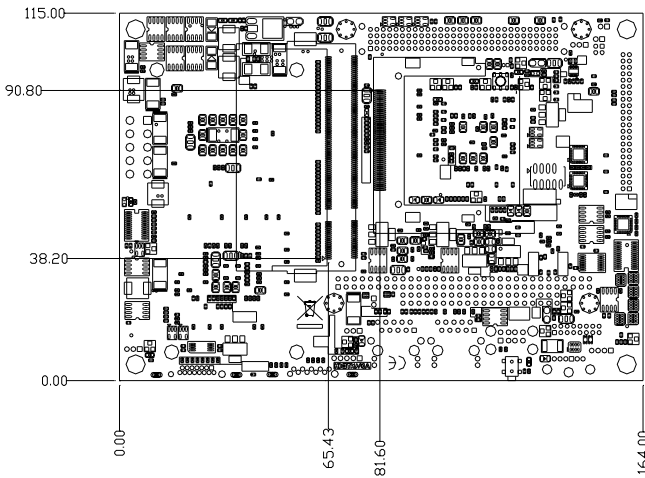

Figure E.2: PCM-4380 Mechanical Drawing (Solder Side)