

PCM-3540T/R LVDS Transmitter/Receiver Module

Introduction

Traditional LCD configurations are limited in range from 30 to 50 cm. The PCM-3540T/R is an ingenious solution to extend the range of LCD panel monitors. By employing LVDS technology with transmitting and receiving units, LCDs can now be placed up to 12 m away from the computer. The cable connecting the transmitter to the receiver comes in various lengths: 2 m, 3 m, 5 m, 10 and 12 m.

Some of the advantages to using Advantech's PCM-3540T/R are: potential 12 m increase in range of your LCD display, Advantech's transmitter-cable-receiver combinations exceed CE and FCC Class A, EMI standards. Furthermore using the PCM-3540T with an Advantech CPU card/board, equipped with C&T65550 chips, now supports 36-bit XGA TFT LCD. Please refer to the Jumper Settings section for detailed information.

Notes: Advantech has tests show that the LCD signal can be transmitted up to 12 m successfully only if using the PCM-3540T, PCM-3540R and PCM-10354 (LVDS cable) combinations. For better image quality be sure the LCD is grounded firmly.

Specifications

- Standard PC/104 form factor for PCM-3540T
- Supports 18-bit, 24-bit, 36-bit and 48-bit resolutions up to 1024 × 768 TFT LCD
- On-board 44-pin and 16-pin LCD interface
- Transmission distance options: 2 m, 3 m, 5 m, 10 m, 12 m
- On board 4-pin power supply connector for PCM-3540R
- Total max. power consumption for the PCM-3540T/R: 1 A@+5 V

Initial Inspection

In addition to this user's manual, your shipping box should contain the following items, please note that each package is sold separately:

For the PCM-3540T

- 1 PCM-3540T LVDS Transmitter Module
- 1 44-pin LCD Cable (from CPU card/board to PCM3540T)
- 1 PC/104 Support package

For the PCM-3540R

- 1 PCM-3540R LVDS Receiver Module
- 1 PC/104 Support Package

For the PCM-10354

- 1 LVDS Cable
- No Manual



WARNING! Discharge your body's static electric charge by touching the back of the grounded chassis of the system unit (metal) before handling the board. You should avoid contact with materials that hold a static charge such as plastic, vinyl, and styrofoam. The board should be handled only by its edges to avoid static damage to its integrated circuits. Avoid touching the exposed circuit connectors.

Setting Jumpers

You configure the board to match the needs of your application by setting jumpers. A jumper is the simplest kind of electric switch. It consists of two metal pins and a small metal clip (often protected by a plastic cover) that slides over the pins to connect them. To "close" a jumper you connect the pins with the clip. To "open" a jumper you remove the clip. Sometimes a jumper will have three pins, labeled 1, 2, and 3. In this case you would connect either pins 1 and 2 or 2 and 3.

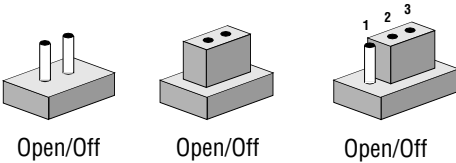

The jumper settings are schematically depicted in this manual as follows:

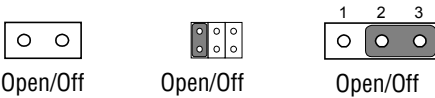

A pair of needle-nose pliers may be helpful when working with jumpers.

If you have any doubts about the best hardware configuration for your application, contact your local distributor or sales representative before you make any changes.

Generally, you simply need a standard cable to make most connections.

PCM-3540T Jumper Settings

JP1: +5 V Power source setting: You can set the PCM-3540T power source from the PC/104 connector or the LCD cable by the following settings:

JP2: DS90C383 programmable strobe select.

Jumper	Setting
JP2: Rising edge strobe NC*: Rising edge strobe	
JP2: Falling edge strobe	



*default

Function	Diagram
* TFT Mode support 18/24/36/48 bits TFT	
LVDS Mode support 18 bits LVDS panels.	
LVDS Mode support 24 bits LVDS panels.	
LVDS Mode support 36 bits LVDS panels.	
LVDS Mode support 48 bits LVDS panels.	

*default

Cable power enable/disable: JP4

This function allows the PCM-3540T to provide power (+5V DC) to the PCM-3540R via the LVDS cable. If you set JP4 as "enable", you should also set JP1 on PCM-3540R as "Power from LVDS cable". It's not recommended to set JP4 as "enable" if the LVDS cable is equal to or longer than 5 meters.

JP4	Setting
Enable	
Disable*	

Panel type selection: JP2 Pin 1-2

Set the LCD type you will use by the following settings:



Pin	Function
1-2	Reserved for STN function
3-4	Enable SHFCLK for TFT/LVDS panels (recommend)*

*default

PCM-3540R Jumper Settings

Power source select: JP5

This function allows the PCM-3540R to get the power (+5 V DC) from the PCM-3540T via the LVDS cable or an external power supply.

JP5	Setting
Power from LVDS cable	
Power from external power connector (CN8)*	

*default

Panel type selection: J4



Set the LCD type you will use by the following settings:

Pin	Function
1-2	Reserved for STN function
2-3	Enable ENVEE for TFT/LVDS panels (recommend)*

*default

LCD voltage selection: JP3

To avoid damaging the LCD, check the LCD voltage carefully then set the LCD voltage with the following setting:

JP3	Setting
5 V	
3.3 V*	

*default

PCM-3540T Pin Assignments



D-Sub 26-Pin Connector (CN7)

Pin Function	Pin Function
1 CLK2P	14 CLK2M
2 GND	15 A0M
3 A0P	16 A1M
4 A1P	17 A2M
5 A2P	18 CLK1M
6 CLK1P	19 GND
7 +5V(Optional)	20 +5V(Optional)
8 GND	21 A3M
9 A3P	22 A4M
10 A4P	23 A5M
11 A5P	24 A6M
12 A6P	25 A7M
13 A7P	26 GND

40-Pin HIROSE Connector (CN2)

Pin Function	Pin Function
1 LCD VDD(+5V)	2 LCD VDD(+5V)
3 GND	4 GND
5 N/C	6 N/C
7 Vcon(optional)	8 GND
9 P0	10 P1
11 P2	12 P3
13 P4	14 P5
15 P6	16 P7
17 P8	18 P9
19 P10	20 P11
21 P12	22 P13
23 P14	24 P15
25 P16	26 P17
27 P18	28 P19
29 P20	30 P21
31 P22	32 P23
33 GND	34 GND
35 SHECLK	36 FLM(V-SYNC)
37 M/(DE)	38 LP(H-SYNC)
39 FNABKI	40 FNVFF

16-pin Header Connector (CN3)

Pin Function	Pin Function
1 LCD VDD(+5V)	2 LCD VDD(+5V)
3 P24	4 P25
5 P26	6 P27
7 P28	8 P29
9 P30	10 P31
11 P32	12 P33
13 P34	14 P35
15 GND	16 GND

44-pin Header Connector (CN4)

Pin Function	Pin Function
1 N/C	2 N/C
3 GND	4 GND
5 LCD VDD(+5V)	6 LCD VDD(+5V)
7 ENVEE	8 GND
9 P0	10 P1
11 P2	12 P3
13 P4	14 P5
15 P6	16 P7
17 P8	18 P9
19 P10	20 P11
21 P12	22 P13
23 P14	24 P15
25 P16	26 P17
27 P18	28 P19
29 P20	30 P21
31 P22	32 P23
33 GND	34 GND
35 SHECLK	36 FLM(V-SYNC)
37 M/(DE)	38 LP(H-SYNC)
39 GND	40 FNABKI
41 N/C	42 STN_25M
43 FNVDD	44 LCD VDD(+5V)

Type h 40-Pin HIROSE Connector - 48 bits (CN5)

Pin Function	Pin Function
1 LCD VDD(+5V)	2 LCD VDD(+5V)
3 GND	4 GND
5 N/C	6 N/C
7 Vcon(optional)	8 GND
9 P24	10 P25
11 P26	12 P27
13 P28	14 P29
15 P30	16 P31
17 P32	18 P33
19 P34	20 P35
21 P36	22 P37
23 P38	24 P39
25 P40	26 P41
27 P42	28 P43
29 P44	30 P45
31 P46	32 P47
33 GND	34 GND
35 SHECLK2	36 FLM2(V-SYNC)
37 M2/(DE)	38 LP2(H-SYNC)
39 N/C	40 N/C

Pin mapping for TFT interface

Pin Name	18/24 bits TFT	36/48 bits TFT	Remark
P0	B0	B00	
P1	B1	B01	
P2	B2	B02	
P3	B3	B03	
P4	B4	B04	
P5	B5	B05	
P6	B6	BE0	
P7	B7	BE1	
P8	G0	BE2	
P9	G1	BE3	
P10	G2	BE4	
P11	G3	BE5	
P12	G4	G00	
P13	G5	G01	
P14	G6	G02	
P15	G7	G03	
P16	R0	G04	
P17	R1	G05	
P18	R2	GE0	
P19	R3	GE1	
P20	R4	GE2	
P21	R5	GE3	
P22	R6	GE4	
P23	R7	GE5	
P24		R00	
P25		R01	
P26		R02	
P27		R03	
P28		R04	
P29		R05	

8-pin Header connector (CN6)

Pin Function
1 VCC(+3.3V)
2 TDO
3 TDI
4 ispEN
5 N/C
6 TMS
7 GND
8 TCK

pin mappings cont...

Pin Name	18/24 bits TFT	36/48 bits TFT	Remark
P31		RF1	
P32		RF2	
P33		RF3	
P34		RF4	
P35		RF5	
P36		B06	
P37		B07	
P38		BE6	
P39		BE7	
P40		G06	
P41		G07	
P42		GE6	
P43		GE7	
P44		R06	
P45		R07	

40-Pin HIROSE Connector (CN1)

Pin Function	Pin Function
1 LCD VDD(+5V)	2 LCD VDD(+5V)
3 GND	4 GND
5 N/C	6 N/C
7 Vcon(optional)	8 GND
9 P0	10 P1
11 P2	12 P3
13 P4	14 P5
15 P6	16 P7
17 P8	18 P9
19 P10	20 P11
21 P12	22 P13
23 P14	24 P15
25 P16	26 P17
27 P18	28 P19
29 P20	30 P21
31 P22	32 P23
33 GND	34 GND
35 SHFCLK	36 FLM(V-SYNC)
37 M/(DE)	38 LP(H-SYNC)
39 ENABK1	40 ENVFF

PCM-3540R Pin Assignments



D-Sub 26-Pin Connector (CN8)

Pin Function	Pin Function
1 CLK2P	14 CLK2M
2 GND	15 A0M
3 A0P	16 A1M
4 A1P	17 A2M
5 A2P	18 CLK1M
6 CLK1P	19 GND
7 +5V(Optional)	20 +5V(Optional)
8 GND	21 A3M
9 A3P	22 A4M
10 A4P	23 A5M
11 A5P	24 A6M
12 A6P	25 A7M
13 A7P	26 GND

16-pin Header Connector (CN2)

Pin Function	Pin Function
1 LCD VDD(+5V)	2 LCD VDD(+5V)
3 P24	4 P25
5 P26	6 P27
7 P28	8 P29
9 P30	10 P31
11 P32	12 P33
13 P34	14 P35
15 GND	16 GND

Type: 3-Pin Header Connector (CN3)

Pin Function
CN3 Reserved for STN function.

Type: 3-Pin Header Connector (CN4)

Pin Function
CN4 Reserved for STN function.

40-Pin Header Connector (CN5)

Pin	Function	Pin	Function
1	N/C	2	N/C
3	GND	4	GND
5	LCD_VDD(+5V)	6	LCD_VDD(+5V)
7	ENVFF	8	GND
9	P0	10	P1
11	P2	12	P3
13	P4	14	P5
15	P6	16	P7
17	P8	18	P9
19	P10	20	P11
21	P12	22	P13
23	P14	24	P15
25	P16	26	P17
27	P18	28	P19
29	P20	30	P21
31	P22	32	P23
33	GND	34	GND
35	SHFCLK	36	FLM(V-SYNC)
37	M/(DE)	38	LP(H-SYNC)
39	GND	40	ENABKL
41	N/C	42	STN_25M
43	ENVDD	44	LCD_VDD(+5V)

40-Pin HIROSE (CN6)

Pin	Function	Pin	Function
1	LCD_VDD(+5V)	2	LCD_VDD(+5V)
3	GND	4	GND
5	N/C	6	N/C
7	Vcon(optional)	8	GND
9	P24	10	P25
11	P26	12	P27
13	P28	14	P29
15	P30	16	P31
17	P32	18	P33
19	P34	20	P35
21	P36	22	P37
23	P38	24	P39
25	P40	26	P41
27	P42	28	P43
29	P44	30	P45
31	P46	32	P47
33	GND	34	GND
35	SHECLK2	36	FLM2(V-SYNC)
37	M2/(DE)	38	LP2(H-SYNC)
39	N/C	40	N/C

Type: 4-Pin Header Connector (CN7)

Pin	Function
1	+12V
2	GND
3	GND
4	+5V

Pin mapping for TFT interface

Pin Name	18/24 bits TFT	36/48 bits TFT	Remark
P0	B0	B00	
P1	B1	B01	
P2	B2	B02	
P3	B3	B03	
P4	B4	B04	
P5	B5	B05	
P6	B6	BE0	
P7	B7	BE1	
P8	G0	BE2	
P9	G1	BE3	
P10	G2	BE4	
P11	G3	BE5	
P12	G4	G00	
P13	G5	G01	
P14	G6	G02	
P15	G7	G03	
P16	R0	G04	
P17	R1	G05	
P18	R2	GE0	
P19	R3	GE1	
P20	R4	GE2	
P21	R5	GE3	
P22	R6	GE4	
P23	R7	GE5	
P24		R00	
P25		R01	
P26		R02	
P27		R03	
P28		R04	
P29		R05	
P30		RE0	
P31		RE1	
P32		RE2	
P33		RE3	
P34		RE4	
P35		RE5	
P36		BO6	
P37		BO7	

pin mappings cont..

P38	BE6
P39	BE7
P40	GO6
P41	GO7
P42	GE6
P43	GE7
P44	RO6
P45	RO7
P46	RE6
P47	RE7

* low active

Appendix A

The following configuration is a real world example of Advantech's CPU cards/boards equipped with the SMI 721 chipsets operating 48-bit TFT LCD.

Advantech CPU boards/cards:

PCM-9572 Low Power Pentium III SBC

LVDS module

Transmitter: PCM-3540T-00B1

Receiver: PCM-3540R-00B1

Cable (2 meter): 1700262004

Flat Panel Cable (from PCM-3540R to LCD):

FPC

LCD:

48-bit TFT LCD, AU L170E3/M170EN04

You may need to modify your CPU BIOS to operate the LCD. Please contact Advantech's Customer Service Dept. for the modified BIOS.

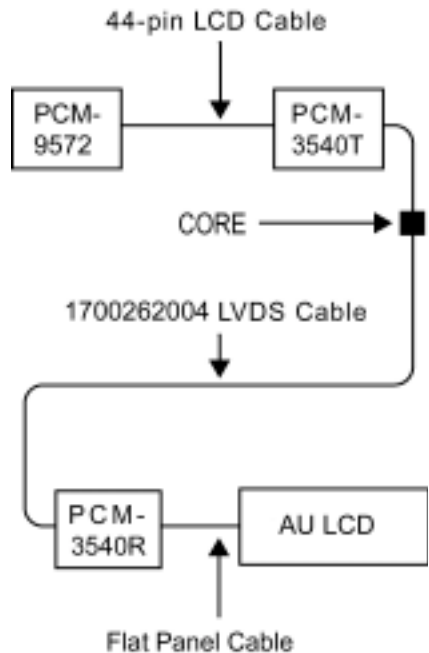

Appendix B

For STN panel contrast and back-light control, the PCM-3540R's CN4 and CN5 connectors must be used in conjunction with a Variable Resistor.

PCM-3540 Contrast Control (CN4):

A VR (Variable Resistor) is needed to contrast control. Please refer to the VR connection diagram below for details.

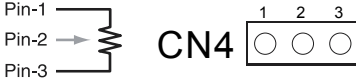

PCM-3540R Contrast control (CN4)

Pin No.	Function
1	ZNVEE
2	Contrast ADJ (VSAFE)
3	GND

PCM-3540 Back-Light Control (CN5):

A VR (Variable Resistor) is needed to Back-Light control. Please refer to the VR connection diagram below for details.

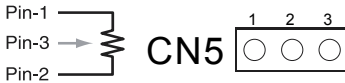

PCM-3540R Back-Light control (CN5)

Pin No.	Function
1	+12 V
2	GND
3	Back-Light ADJ (BNK)

PCM-3540R external power connector pin assignments(CN7)

Pin No.	Function
1	+12 V
2	GND
3	GND
4	+5 V