

# **PCM-3386**

**Intel Celeron® M SBC with  
CFC/USB/LAN/LPT/COM/PCI 104  
CPU**

## **User's Manual**

## Copyright

This document is copyrighted, © 2005. All rights are reserved. The original manufacturer reserves the right to make improvements to the products described in this manual at any time without notice.

No part of this manual may be reproduced, copied, translated or transmitted in any form or by any means without the prior written permission of the original manufacturer. Information provided in this manual is intended to be accurate and reliable. However, the original manufacturer assumes no responsibility for its use, nor for any infringements upon the rights of third parties that may result from such use.

## Acknowledgements

Award is a trademark of Award Software International, Inc.  
IBM, PC/AT, PS/2 and VGA are trademarks of International Business Machines Corporation.

Intel and Pentium are trademarks of Intel Corporation.

Microsoft Windows® is a registered trademark of Microsoft Corp.

RTL is a trademark of Realtek Semi-Conductor Co., Ltd.

ESS is a trademark of ESS Technology, Inc.

Creative is a trademark of Creative Technology LTD.

All other product names or trademarks are properties of their respective owners.

For more information on this and other Advantech products, please visit our websites at: **<http://www.advantech.com>**

**<http://www.advantech.com/eplatform>**

For technical support and service, please visit our support website at:

**<http://www.advantech.com/support>**

This manual is for the PCM-3386.

Part No. 2006338610

1st Edition, Printed Sep. 2005

## Packing List

---

Before you begin installing your card, please make sure that the following materials have been shipped:

- 1 PCM-3386 all-in-one single board computer
- 1 CD disk for utility and drivers
- 1 startup manual
- 1 6P(MINI-DIN)-6P(Wafer 2.0mm) 5cm (p/n: 1703060053)
- 1 IDE cable (p/n: 1701440350)
- 1 IDE cable (44pin to 40/44pin) (p/n: 1701440504)
- 1 Wire ATX power (p/n: 1703200380)
- 1 Ethernet RJ-45 Conn.conversion cable (p/n: 1701100202)
- 1 KB / MOUSE Y-cable (p/n: 1700060202)
- 1 COM port cable (p/n: 1701200220)
- 1 USB Cable Adaptor (p/n: 1700000897)
- 1 VGA cable (p/n: 1700000898)
- 1 FLAT CABLE D-SUB25P(F)/26P-2.0MM 25CM (p/n:1700000916)
- 1 WIRE 5P-2.0MM/AUDIO JACK(B+R) 10CM (p/n: 1700000918)

If any of these items are missing or damaged, contact your distributor or sales representative immediately.

<b>Model No. List</b>	<b>Description</b>
PCM-3386F-M0A1	Embedded onboard Celeron M 600 w/0 cache SBC w/Audio, VGA, LCD

*This device complies with the requirements in part 15 of the FCC rules: Operation is subject to the following two conditions:*

## **FCC**

- 1. This device may not cause harmful interference, and*
- 2. This device must accept any interference received, including interference that may cause undesired operation*

*This equipment has been tested and found to comply with the limits for a Class A digital device, pursuant to Part 15 of the FCC Rules. These limits are designed to provide reasonable protection against harmful interference when the equipment is operated in a commercial environment. This equipment generates, uses, and can radiate radio frequency energy and, if not installed and used in accordance with the instruction manual, may cause harmful interference to radio communications. Operation of this device in a residential area is likely to cause harmful interference in which case the user will be required to correct the interference at his/her own expense. The user is advised that any equipment changes or modifications not expressly approved by the party responsible for compliance would void the compliance to FCC regulations and therefore, the user's authority to operate the equipment.*

**Caution!**



*There is a danger of a new battery exploding if it is incorrectly installed. Do not attempt to recharge, force open, or heat the battery. Replace the battery only with the same or equivalent type recommended by the manufacturer. Discard used batteries according to the manufacturer's instructions.*

**Achtung!**

## **Additional Information and Assistance**

---

1. Visit the Advantech web site at **www.advantech.com** where you can find the latest information about the product.
2. Contact your distributor, sales representative, or Advantech's customer service center for technical support if you need additional assistance.

Please have the following information ready before you call:

- Product name and serial number
- Description of your peripheral attachments
- Description of your software (operating system, version, application software, etc.)
- A complete description of the problem
- The exact wording of any error messages



# Contents

<b>Chapter 1</b>	<b>General Information .....</b>	<b>2</b>
1.1	Introduction .....	2
1.2	Features .....	2
1.3	Specifications .....	2
1.4	Board layout: dimensions .....	4
	Figure 1.1:Board layout: dimension(component side) ...	4
	Figure 1.2:Board layout: dimension (solder side) .....	5
<b>Chapter 2</b>	<b>Installation .....</b>	<b>8</b>
2.1	Connectors.....	8
	Table 2.1:Connectors .....	8
2.2	Locating Connectors .....	9
	Figure 2.1:Jumper & Connector (component side) .....	9
	Figure 2.2:Jumper & Connector (solder side) .....	10
2.3	Installing SO-DIMMs .....	11
2.4	IDE, CDROM hard drive connector (CN5) .....	11
2.4.1	Connecting the hard drive .....	11
2.5	Solid State Disk.....	12
2.5.1	CompactFlash (CN16) .....	12
2.6	Keyboard and PS/2 mouse connector (CN4) .....	12
2.7	Front Panel Connector (CN6) .....	12
2.7.1	Power Switch (pin 1-2 of CN6) .....	12
2.7.2	Reset switch (pin 3-4 of CN6) .....	13
2.8	Power connectors (CN8,CN10).....	13
2.8.1	ATX power connector, +5V (CN8) .....	13
2.8.2	CPU Fan power supply connector (CN10) .....	13
2.9	ATX AUX connector (CN13).....	13
2.9.1	ATX feature (CN13) .....	13
2.10	Audio interfaces (CN11,CN15).....	13
2.10.1	Audio connector(Line Out)(CN11) .....	13
2.10.2	Audio connector(Line In/Mic In)(CN15) .....	14
2.11	COM port connector (CN17) .....	14
2.12	CRT/LVDS interface connections (CN14,CN12).....	14
2.12.1	CRT display connector (CN14) .....	14
2.12.2	LVDS connector (CN12) .....	14
2.13	Ethernet configuration (CN9).....	14
2.13.1	Network boot .....	15
2.14	USB connectors (CN18).....	15
<b>Chapter 3</b>	<b>Software Configuration .....</b>	<b>18</b>
3.1	Introduction .....	18

3.2	Connections to One Standard LCDs .....	19
3.2.1	LG LM150X06 (1024x768 LVDS TFT LCD) .....	19
	Table 3.1:Connections to LCD/ Flat Panel (CN12)...	19
<b>Chapter 4</b>	<b>Award BIOS Setup.....</b>	<b>22</b>
4.1	System test and initialization.....	22
4.1.1	System configuration verification.....	22
4.2	Award BIOS setup .....	23
4.2.1	Entering setup .....	23
	Figure 4.1:BIOS setup program initial screen .....	23
4.2.2	Standard CMOS Features setup.....	24
	Figure 4.2:CMOS Features setup.....	24
4.2.3	Advanced BIOS Features setup .....	25
	Figure 4.3:Advanced BIOS Features setup.....	25
4.2.4	Advanced Chipset Features setup .....	26
	Figure 4.4:Advanced Chipset Features setup .....	26
4.2.5	Integrated Peripherals .....	26
	Figure 4.5:Integrated Peripherals.....	26
4.2.6	Power Management Setup .....	27
	Figure 4.6:Power Management Setup.....	27
4.2.7	PnP/PCI Configurations.....	27
	Figure 4.7:PnP/PCI Configurations .....	27
4.2.8	Frequency/Voltage Control.....	28
	Figure 4.8:Frequency/Voltage Control .....	28
4.2.9	Load Optimized Defaults .....	29
4.2.10	Set Password .....	29
	Figure 4.9:To Establish Password .....	30
4.2.11	Save & Exit Setup.....	31
4.2.12	Exit Without Saving .....	31
	Figure 4.10:Exit Without Saving .....	31
<b>Chapter 5</b>	<b>Chipset Setup.....</b>	<b>34</b>
5.1	Introduction .....	34
5.1.1	Chipset .....	34
5.2	Installation of the Chipset driver.....	34
5.2.1	Installation for Windows 98/ME/2000/XP .....	34
5.3	Further Information .....	38
<b>Chapter 6</b>	<b>VGA Graphic Setup .....</b>	<b>40</b>
6.1	Introduction .....	40
6.1.1	Chipset .....	40
6.1.2	Display memory.....	40
6.1.3	Display types.....	40
6.1.4	Dual/Simultaneous Display .....	41
	Figure 6.1:Selecting Display Settings.....	41
6.2	Installation of the PCI Graphic driver .....	42

	6.2.1	Installation for Windows 98/ME/2000/XP .....	42
	6.2.2	VGA potential problems.....	45
	6.3	Further Information .....	47
<b>Chapter</b>	<b>7</b>	<b>Audio Setup.....</b>	<b>50</b>
	7.1	Introduction .....	50
	7.2	Driver installation.....	50
	7.2.1	Before you begin.....	50
	7.2.2	Windows 9x/2000/Me/XP drivers .....	51
<b>Chapter</b>	<b>8</b>	<b>PCI Bus Ethernet Interface.....</b>	<b>54</b>
	8.1	Introduction .....	54
	8.2	Features .....	54
	8.3	Installation of Ethernet Driver.....	54
	8.3.1	Installation for Windows 2000 .....	55
	8.3.2	Installation for Windows NT .....	59
	8.4	Further information .....	65
<b>Chapter</b>	<b>9</b>	<b>USB Setup .....</b>	<b>68</b>
	9.1	Introduction .....	68
	9.2	Installation of the PCI USB driver .....	68
	9.2.1	Installation for Windows 98/ME/2000/XP.....	68
	9.2.2	Installation for windows 2000 .....	71
	9.3	Further Information .....	76
<b>Appendix</b>	<b>A</b>	<b>Programming Watchdog Timer.....</b>	<b>78</b>
	A.1	Watchdog programming.....	78
<b>Appendix</b>	<b>B</b>	<b>Pin Assignments .....</b>	<b>82</b>
	B.1	LCD Inverter Connector (CN1) .....	82
		Table B.1:LCD Inverter Connector(CN1).....	82
	B.2	Battery Connector (CN2).....	82
		Table B.2:Battery Connector (CN2).....	82
	B.3	Front Panel connector (CN6).....	83
		Table B.3: Front Panel connector (CN6).....	83
	B.4	Power Connector(CN8).....	83
		Table B.4:Power Connector (CN8) .....	83
	B.5	LAN Connector (CN9).....	84
		Table B.5: LAN Connector(CN9) .....	84
	B.6	Fan Connector(5V Only) (CN10) .....	84
		Table B.6:Fan Connector(5V Only) (CN10).....	84
	B.7	Audio Connector(Line Out) (CN11).....	85
		Table B.7:Audio Connector(Line Out)(CN11).....	85
	B.8	KB/MS Connector (CN4).....	85
		Table B.8:KB/MS connector (CN4) .....	85
	B.9	2ch LVDS Connector (CN12).....	86

	Table B.9:2ch LVDS Connector (CN12) .....	86
B.10	IDE 44pin Connector (CN5) .....	87
	Table B.10:IDE 44pin connector (CN5).....	87
B.11	LPT Connector (CN19) .....	88
	Table B.11:LPT Connector (CN19).....	88
B.12	ATX AUX Connector (CN13) .....	88
	Table B.12:ATX Ctrl Connector (CN13) .....	88
B.13	Audio Line-in/Mic Connector (CN15) .....	89
	Table B.13:Audio Connector (CN15).....	89
B.14	CRT Connector (CN14) .....	89
	Table B.14:CRT Connector (CN14).....	89
B.15	USB Connector (CN18) .....	90
	Table B.15:USB Connector (CN18).....	90
B.16	COM Port Connector (CN17) .....	91
	Table B.16:COM Port Connector (CN17).....	91
<b>Appendix C</b>	<b>System Assignments .....</b>	<b>94</b>
C.1	System I/O Ports.....	94
	Table C.1:System I/O Ports .....	94
C.2	1st MB memory map.....	95
	Table C.2:1st MB memory map .....	95
C.3	DMA channel assignments.....	95
	Table C.3:DMA channel assignments .....	95
C.4	Interrupt assignments .....	96
	Table C.4:Interrupt assignments .....	96
<b>Appendix D</b>	<b>Mechanical Drawings.....</b>	<b>98</b>
D.1	Mechanical Drawings.....	98
	Figure D.1: Mech Drawing (component side).....	98
	Figure D.2: Mech Drawing (solder side).....	99

## **General Information**

This chapter gives background information on the PCM-3386.

Sections include:

- Introduction
- Features
- Specifications
- Board layout and dimensions

# Chapter 1 General Information

## 1.1 Introduction

---

The PCM-3386 is a solid, general purpose single board computer(SBC) to satisfy various industrial and multimedia applications. With onboard Intel® Celeron® M 600 w/0 cache, 10/100 Base-T LAN, DDR memory, 2 channel 18-bit LVDS, CRT Display function and PCI interface, the PCM-3386's design is 120-pin PCI PC104+ form factor and it supports 6 USB-2.0 ports.

## 1.2 Features

---

- Onboard Intel® Celeron® M 600 w/0 cache
- Memory up to 1 GB DDR RAM
- With Vcore 2 phase design for more stable system design
- Supports 10/100Base-T Ethernet
- Supports 6 Host USB2.0 ports
- Supports dual display CRT+ LVDS
- Supports Audio. Line In, Mic In and Line Out.

## 1.3 Specifications

---

### Standard SBC Functions

- **CPU:** Celeron®M 600
- **BIOS:** Award 512 KB Flash memory
- **System memory:** 200 pin SO-DIMM socket, support Double Data Rate (DDR)128 MB to 1 GB, accepts 128/256/512/1000 MB DDR200/266 DRAM.
- **System chipset:** Intel 852GM (GMCH)/ICH4 chipset 400Mhz FSB
- **Enhanced IDE interface:** One Enhanced IDE interface supports up to two EIDE devices. BIOS auto-detect, PIO Mode 3 or Mode 4 transfer, Ultra DMA33 mode supported
- **Serial ports:** Two serial RS-232 ports

- **Parallel port:** One parallel port, supports SPP/EPP/ECP mode
- **Keyboard/mouse connector:** Wafer Box
- **Power management:** Supports Advanced Power Management /ACPI
- **Watchdog timer:** 255-level timer intervals, setup by software, generates system reset
- **USB:** Six USB 2.0 compliant host ports
- **Expansion:** Supports 120-pin PCI104 module connector

### **Solid State Disk**

- Supports one 50-pin socket for CFC type I, (Type II for optional)

### **VGA/LCD Interface**

- **Chipset:** Intel 852GM Integrated
- **Frame buffer:** UMA architecture, Up to 64 MB of dynamic video memory allocation
- **Display mode:** CRT Modes: up to 1600 x 1200 at 85-Hz and 2048 x 1536 at 75-Hz
- **LCD mode:** Dual channel LVDS panel support up to UXGA panel resolution with frequency range from 25 MHz to 112 MHz
- **LVDS:** Support 2 channel (18-bit) LVDS LCD panel

### **Ethernet interface**

- **Chipset:**
- Intel 82562Em
- **Ethernet interface:**
- IEEE 802.3u 10/100BASE-T Fast Ethernet compatible

### **Audio Function**

- **Chipset:** Realtek ALC202
- **Audio controller:** AC'97 2.0-compliant, Line in, Line out, Mic In

### **Mechanical and Environmental**

- **Dimensions:** (L x W)115 x 105 mm complain with PCI-104 1.0
- **Power supply Voltage:**ATX, Power required, +5V, +12V, 5V standby
- **Power Requirement:** Celeron M 600 MHz+ DDR 512MB:

**Max:**2.16A@5V

**Average:**2.02A@5V

- **Operating temperature:**0 ~ 60° C (32~140° F)
- **Operating Humidity:**0% ~ 95% Relative Humidity, noncondensing
- **Weight:** 0.277 kg (with heatsink)

## 1.4 Board layout: dimensions

---

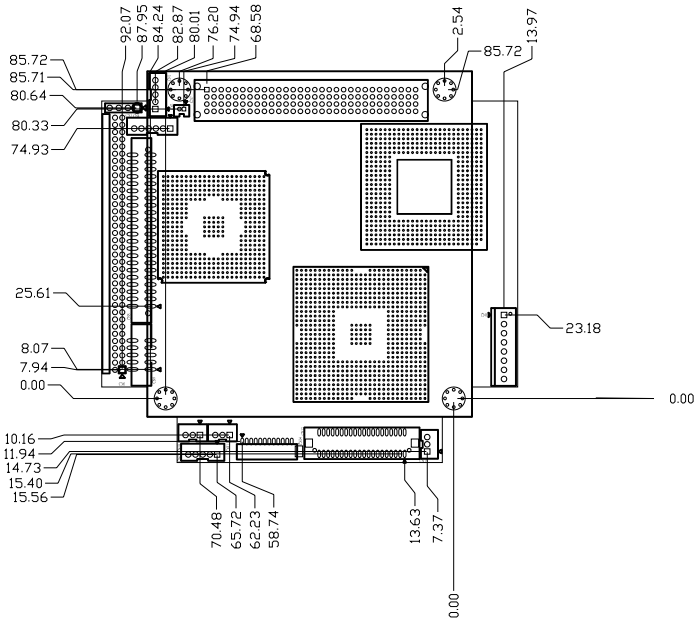

*Figure 1.1: Board layout: dimension(component side)*

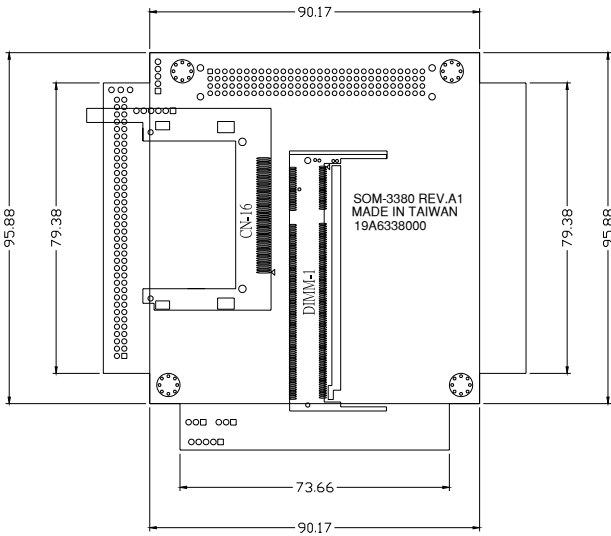

**Figure 1.2: Board layout: dimension (solder side)**



## **Installation**

This chapter explains the setup procedures of PCM-3386 hardware, including instructions on setting jumpers and connecting peripherals, switches and indicators. Be sure to read all safety precautions before you begin the installation procedure.

# Chapter 2 Installation

## 2.1 Connectors

---

On-board connectors link the PCM-3386 to external devices such as hard disk drives, a keyboard, or floppy drives. The table below lists the function of each of the board's connectors.

---

*Table 2.1: Connectors*

<b>Label</b>	<b>Function</b>
CN1	LCD Inverter Con.
CN2	Battery Con.
CN4	KB/MS Con.
CN5	IDE 44pin Con.
CN6	Power/Reset Header/Buzzer
CN7	PCI 104 Con.
CN8	Power Con.
CN9	LAN Con.
CN10	Fan Con. (5V Only)
CN11	Audio Line-out connector
CN12	LVDS Con.
CN13	ATX AUX Con.
CN14	CRT Con.
CN15	Audio Line-in/Mic connector
CN16	CF connector
CN17	COM Port Con.
CN18	USB Con.
CN19	LPT Con.

---

## 2.2 Locating Connectors

---

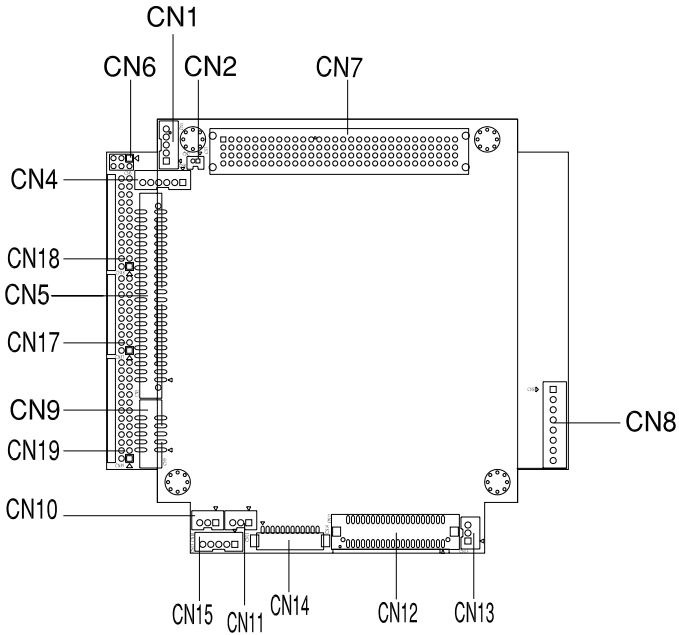

**Figure 2.1: Jumper & Connector (component side)**

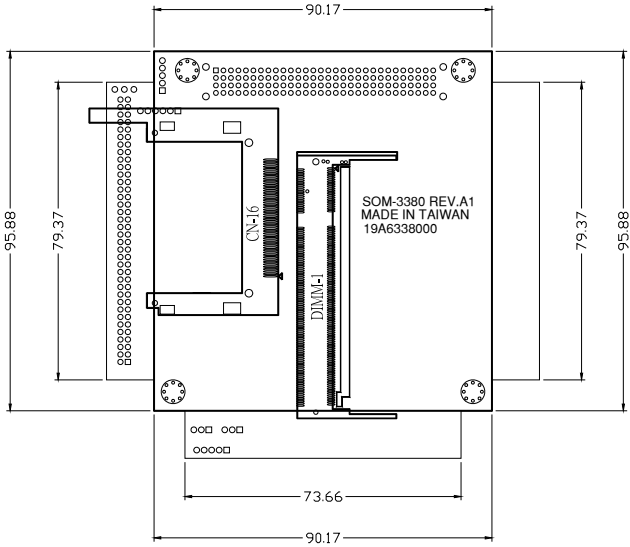

**Figure 2.2: Jumper & Connector (solder side)**

## 2.3 Installing SO-DIMMs

---

The procedure for installing SO-DIMMs is described below. Please follow these steps carefully. The number of pins are different on either side of the breaks, so the module can only fit in one way. SO-DIMMs modules have different pin contacts on each side, and therefore have a higher pin density.

1. Make sure that the two handles of the SO-DIMMs socket are in the “open” position. i.e. The handles remain leaning outward.
2. Slowly slide the SO-DIMMs module along the plastic guides on both ends of the socket.
3. Press the SO-DIMMs module right down into the socket, until you hear a click. This is when the two handles have automatically locked the memory module into the correct position of the socket.

To **remove** the memory module, just push both handles outward, and the module will be ejected from the socket.

## 2.4 IDE, CDROM hard drive connector (CN5)

---

The PCM-3386 provides 1 IDE channel to which you can attach up to two Enhanced Integrated Device Electronics hard disk drives or CDROM to the PCM-3386's internal controller. The PCM-3386's IDE controller uses a PCI interface. This advanced IDE controller supports faster data transfer, PIO mode 3, mode 4 and UDMA/33.

### 2.4.1 Connecting the hard drive

It requires one of two cables (not included in this package), depending on the drive size. 1.8" and 2.5" drives need a 1 x 44-pin to 2 x 44-pin flat-cable connector. 3.5" drives use a 1 x 44-pin to 2 x 40-pin connector.

Wire number 1 on the cable is red or blue, and the other wires are gray.

1. Connect one end of the cable to CN5. Make sure that the red (or blue) wire corresponds to pin 1 on the connector, which is labeled on the board (on the right side).
2. Plug the other end of the cable into the Enhanced IDE hard drive, with pin 1 on the cable corresponding to pin 1 on the hard drive. (See your hard drive's documentation for the location of the connector.)

If desired, connect a second drive as described above.

Unlike floppy drives, IDE hard drives can connect to either end of the cable. If you install two drives, you will need to set one as the master and one as the slave by using jumpers on the drives. If you install only one drive, set it as the master.

## **2.5 Solid State Disk**

---

The PCM-3386 provides a CompactFlash™ card socket for Solid state disk solutions.

### **2.5.1 CompactFlash (CN16)**

The CompactFlash card shares a secondary IDE channel which can be enabled/disabled via the BIOS settings.

## **2.6 Keyboard and PS/2 mouse connector (CN4)**

---

The PCM-3386 board provides a keyboard connector that supports both a keyboard and a PS/2 style mouse. In most cases, especially in embedded applications, a keyboard is not used. If the keyboard is not present, the standard PC/AT BIOS will report an error or fail during power-on self-test (POST) after a reset. The PCM-3386's BIOS standard setup menu allows you to select "All, But Keyboard" under the "Halt On" selection. This allows no-keyboard operation in embedded system applications, without the system halting under POST.

## **2.7 Front Panel Connector (CN6)**

---

Next, you may want to install external switches to monitor and control the PCM-3386. These features are optional: install them only if you need them. The Front Panel connector (CN6) is a 6-pin male, dual in-line header. It provides hardware reset, ATX power ON/OFF switch connector, and Buzzer.

### **2.7.1 Power Switch (pin 1-2 of CN6)**

If your computer case is equipped with an ATX power supply, you should connect the power on/off button on your computer case to CN6. This

connection enables you to turn your computer on and off.

### **2.7.2 Reset switch (pin 3-4 of CN6)**

If you install a reset switch, it should be an open single pole switch. Momentarily pressing the switch will activate a reset. The switch should be rated for 10 mA, 5 V.

## **2.8 Power connectors (CN8,CN10)**

---

### **2.8.1 ATX power connector, +5V (CN8)**

Supplies main power to the PCM-3386 (+5V,+12V) and to devices that require.

### **2.8.2 CPU Fan power supply connector (CN10)**

Provides power supply +5V to CPU cooling fan.

## **2.9 ATX AUX connector (CN13)**

---

### **2.9.1 ATX feature (CN13)**

The PCM-3386 can support an advanced soft power switch function, if an ATX power supply is used.

Important      *Make sure that the ATX power supply can take at least a 500 mA load on the 5 V standby lead (5VSB). If not, you may have difficulty powering on your system.*

## **2.10 Audio interfaces (CN11,CN15)**

---

The PCM-3386 is equipped with a high quality audio interface, which provides 16-bit CD-quality recording and playback as well as OPL3 compatible FM music. It is supported by all major operating systems and is completely compatible with Sound Blaster Pro.

### **2.10.1 Audio connector(Line Out)(CN11)**

The PCM-3386 provides all major audio signals on a 3-pin flat-cable connector, CN11. The audio signals include Microphone in (mono), Line out (stereo). You will need an adapter cable if you use traditional jack connectors for these audio signals.

## **2.10.2 Audio connector(Line In/Mic In)(CN15)**

The PCM-3386 provides all major audio signals on a 5-pin flat-cable connector, CN15. The audio signals include Microphone in (mono), Line in (stereo).

## **2.11 COM port connector (CN17)**

---

The PCM-3386 provides two RS-232 serial ports in one COM port connector. It provides connections for serial devices (a mouse, etc.) or a communication network. You can find the pin assignments for the COM port connector in Appendix B.

## **2.12 CRT/LVDS interface connections (CN14,CN12)**

---

The PCM-3386's VGA interface can drive conventional CRT displays and is capable of driving a wide range of LVDS flat panel displays. The board has three connectors to support these displays: one for standard CRT VGA monitors, one for LVDS type LCD panels.

### **2.12.1 CRT display connector (CN14)**

CN14 is a 12-pin, dual-inline header used for conventional CRT displays. A simple one-to-one adapter can be used to match CN14 to a standard 15-pin D-SUB connector commonly used for VGA. Users can drive a standard progressive scan analog monitor with pixel resolution up to 1600 x 1200 at 85 Hz and up to 2048 x 1536 at 75 Hz. Pin assignments for CRT display connector CN14 are detailed in Appendix B.

### **2.12.2 LVDS connector (CN12)**

The PCM-3386 uses the Intel 852 GM chipset that supports single- or dual-channel LVDS panel up to UXGA panel resolution with frequency range from 25MHz to 112MHz.

The PCM-3386 supports single or dual-channel LVDS panels up to UXGA panel resolution with frequency range from 25MHz to 112MHz. The display mode can be 2 channel (2 x 18bit) LVDS LCD panel displays.

## **2.13 Ethernet configuration (CN9)**

---

The PCM-3386 is equipped with a high performance 32-bit PCI-bus Ethernet interface which is fully compliant with IEEE 802.3U 10/100Mbps CSMA/CD standards. It is supported by all major network operating systems.

### **2.13.1 Network boot**

The Network Boot feature can be utilized by incorporating the Boot ROM image files for the appropriate network operating system. The Boot ROM BIOS files are included in the system BIOS, which is on the utility CD disc.

## **2.14 USB connectors (CN18)**

---

The PCM-3386 board provides up to six USB (Universal Serial Bus) 1.1/2.0 ports. This gives complete Plug and Play, and hot attach/detach for up to 127 external devices. The USB interfaces comply with USB specification Rev. 1.1.

You will need a USB cable if you use USB connectors. The USB interfaces can be disabled in the system BIOS setup.



## Software Configuration

This chapter details the software configuration information. It shows you how to configure the card to match your application requirements. The AWARD System BIOS is covered in Chapter 4.

Sections include:

- Introduction
- Connections for standard LCDs

# Chapter 3 Software Configuration

## 3.1 Introduction

---

The PCM-3386 system BIOS and custom drivers are located in a 512 Kbyte, Flash ROM device, designated U17. A single Flash chip holds the system BIOS, VGA BIOS and network Boot ROM image. The display can be configured via CMOS settings. This method minimizes the number of chips and difficulty of configuration. To set different types of LCD panels, please choose “panel type” from the “integrated peripherals” menu in CMOS setup.

## 3.2 Connections to One Standard LCDs

The following tables illustrate typical LCD connection pinouts for the PCM-3386.

### 3.2.1 LG LM150X06 (1024x768 LVDS TFT LCD)

<i>Table 3.1: Connections to LCD/ Flat Pannel (CN12)</i>			
LTM10C209A		PCM-3386 CN12	
Pin	Name	Pin	Name
1	GND	3	GND
2	CLK	35	SHFCLK
3	GND	34	GND
4	R0	27	P18
5	R1	28	P19
6	R2	29	P20
7	GND	33	GND
8	R3	30	P21
9	R4	31	P22
10	R5	32	P23
11	GND	34	GND
12	G0	19	P10
13	G1	20	P11
14	G2	21	P12



# CHAPTER 4

## **Award BIOS Setup**

This chapter describes how to set BIOS configuration data.

# Chapter 4 Award BIOS Setup

## 4.1 System test and initialization

---

These routines test and initialize board hardware. If the routines encounter an error during the tests, you will either hear a few short beeps or see an error message on the screen. There are two kinds of errors: fatal and non-fatal. The system can usually continue the boot up sequence with non-fatal errors. Non-fatal error messages usually appear on the screen along with the following instructions:

**press <F1> to RESUME**

Write down the message and press the F1 key to continue the bootup sequence.

### 4.1.1 System configuration verification

These routines check the current system configuration against the values stored in the board's CMOS memory. If they do not match, the program outputs an error message. You will then need to run the BIOS setup program to set the configuration information in memory.

There are three situations in which you will need to change the CMOS settings:

1. You are starting your system for the first time
2. You have changed the hardware attached to your system
3. The CMOS memory has lost power and the configuration information has been erased.

The PCM-3386 Series' CMOS memory has an integral lithium battery backup. The battery backup should last ten years in normal service, but when it finally runs down, you will need to replace the complete unit.

## 4.2 Award BIOS setup

---

Award's BIOS ROM has a built-in Setup program that allows users to modify the basic system configuration. This type of information is stored in battery-backed CMOS RAM so that it retains the Setup information when the power is turned off.

### 4.2.1 Entering setup

Power on the computer and press <Del> immediately. This will allow you to enter Setup.



*Figure 4.1: BIOS setup program initial screen*

## 4.2.2 Standard CMOS Features setup

When you choose the Standard CMOS Features option from the Initial Setup Screen menu, the screen shown below is displayed. This standard Setup Menu allows users to configure system components such as date, time, hard disk drive, floppy drive and display. Once a field is highlighted, on-line help information is displayed in the left bottom of the Menu screen.



*Figure 4.2: CMOS Features setup*

### 4.2.3 Advanced BIOS Features setup

By choosing the Advanced BIOS Features Setup option from the Initial Setup Screen menu, the screen below is displayed. This sample screen contains the manufacturer's default values for the PCM-3386 Series.



*Figure 4.3: Advanced BIOS Features setup*

## 4.2.4 Advanced Chipset Features setup

By choosing the Advanced Chipset Features option from the Initial Setup Screen menu, the screen below is displayed. This sample screen contains the manufacturer's default values for the PCM-3386 Series.

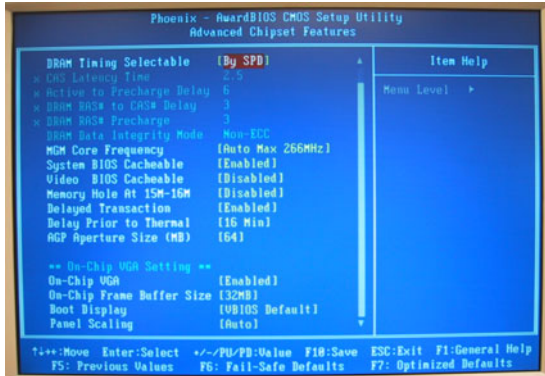

Figure 4.4: Advanced Chipset Features setup

## 4.2.5 Integrated Peripherals

Choosing the Integrated Peripherals option from the Initial Setup Screen menu should produce the screen below. Here we see the manufacturer's default values for the PCM-3386 Series.

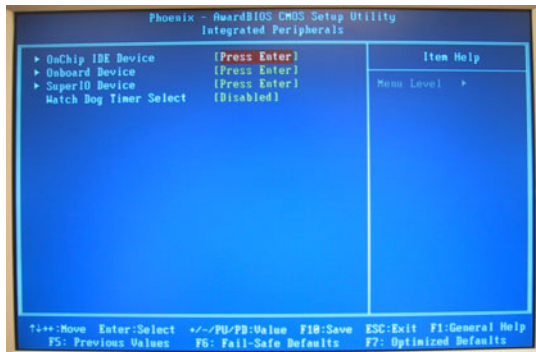

Figure 4.5: Integrated Peripherals

## 4.2.6 Power Management Setup

By choosing the Power Management Setup option from the Initial Setup Screen menu, the screen below is displayed. This sample screen contains the manufacturer's default values for the PCM-3386 Series.



*Figure 4.6: Power Management Setup*

## 4.2.7 PnP/PCI Configurations

By choosing the PnP/PCI Configurations option from the Initial Setup Screen menu, the screen below is displayed. This sample screen contains the manufacturer's default values for the PCM-3386 Series.

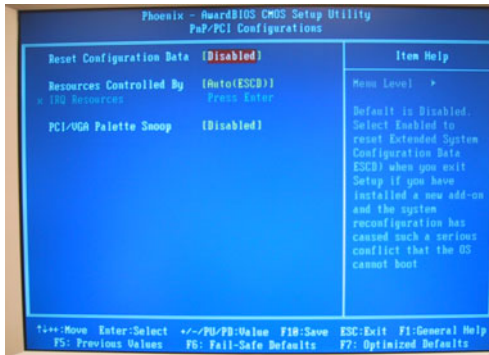

*Figure 4.7: PnP/PCI Configurations*

## 4.2.8 Frequency/Voltage Control

By choosing the Frequency/Voltage Control option from the Initial Setup Screen menu, the screen below is displayed. This sample screen contains the manufacturer's default values for the PCM-3386.

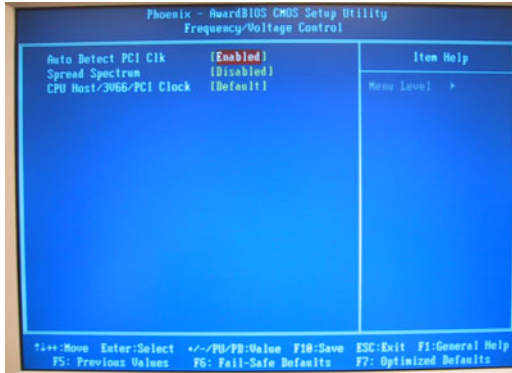

*Figure 4.8: Frequency/Voltage Control*

**Caution** *Incorrect settings in Frequency/Voltage Control may damage the system CPU, video adapter, or other hardware.*

## 4.2.9 Load Optimized Defaults

Load Optimized Defaults loads the default system values directly from ROM. If the stored record created by the Setup program should ever become corrupted (and therefore unusable), these defaults will load automatically when you turn the PCM-3386 Series system on.

## 4.2.10 Set Password

**Note**            *To enable this feature, you should first go to the Advanced BIOS Features menu, choose the Security Option, and select either Setup or System, depending on which aspect you want password protected. Setup requires a password only to enter Setup. System requires the password either to enter Setup or to boot the system.*

*A password may be at most 8 characters long.*

### To Establish Password

1. Choose the Set Password option from the CMOS Setup Utility main menu and press <Enter>.
2. When you see “Enter Password,” enter the desired password and press <Enter>.
3. At the “Confirm Password” prompt, retype the desired password, then press <Enter>

4. Select Save to CMOS and EXIT, type <Y>, then <Enter>.



**Figure 4.9: To Establish Password**

### **To Change Password**

1. Choose the Set Password option from the CMOS Setup Utility main menu and press <Enter>.
2. When you see “Enter Password,” enter the existing password and press <Enter>.
3. You will see “Confirm Password.” Type it again, and press <Enter>.
4. Select Set Password again, and at the “Enter Password” prompt, enter the new password and press <Enter>.
5. At the “Confirm Password” prompt, retype the new password, and press <Enter>.
6. Select Save to CMOS and EXIT, type <Y>, then <Enter>.

### **To Disable Password**

1. Choose the Set Password option from the CMOS Setup Utility main menu and press <Enter>.
2. When you see “Enter Password,” enter the existing password and press <Enter>.
3. You will see “Confirm Password.” Type it again, and press <Enter>.

4. Select Set Password again, and at the “Enter Password” prompt, don’t enter anything; just press <Enter>.
5. At the “Confirm Password” prompt, again don’t type in anything; just press <Enter>.
6. Select Save to CMOS and EXIT, type <Y>, then <Enter>.

#### 4.2.11 Save & Exit Setup

If you select this option and press <Y> then <Enter>, the values entered in the setup utilities will be recorded in the chipset’s CMOS memory. The microprocessor will check this every time you turn your system on and use the settings to configure the system. This record is required for the system to operate.

#### 4.2.12 Exit Without Saving

Selecting this option and pressing <Enter> lets you exit the Setup program without recording any new values or changing old ones.



*Figure 4.10: Exit Without Saving*



## **Chipset Setup**

Introduction

Installation of Chipset drivers

-for Windows 98/2000/XP

Further information

# Chapter 5 Chipset Setup

## 5.1 Introduction

---

The specifications and features are described as follows:

### 5.1.1 Chipset

The PCM-3386 uses a Intel 852GM/ICH4 chipset and 400 MHz FSB.

## 5.2 Installation of the Chipset driver

---

Complete the following steps to install the Chipset driver. Follow the procedures in the flow chart that apply to the operating system that you are using within your PCM-3386.

- Notes:*
- 1. The windows illustrations in this chapter are intended as examples only. Please follow the listed steps, and pay attention to the instructions which appear on your screen.*
  - 2. For convenience, the CD-ROM drive is designated as "D" throughout this chapter.*

### 5.2.1 Installation for Windows 98/ME/2000/XP

To install PCI Graphic driver for Windows 98/2000/XP, please run the set up wizard "Intel(R) Extreme Graphic 2" in CD-ROM. An example of the installation procedure is shown below:

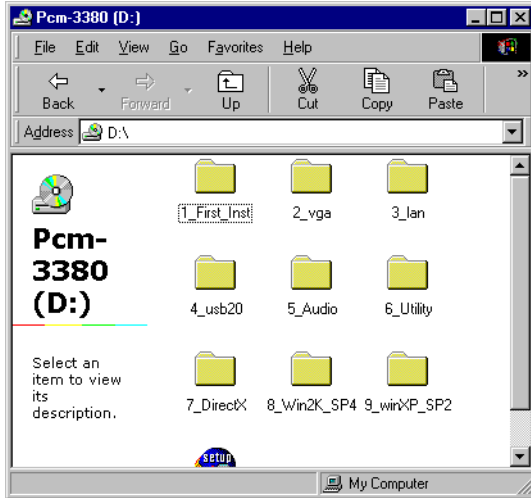

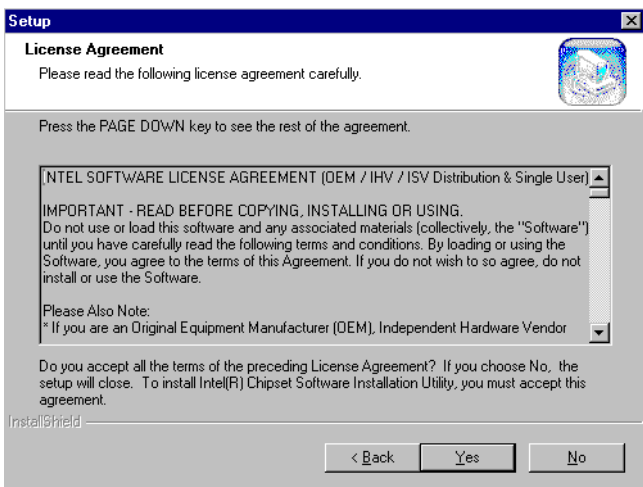
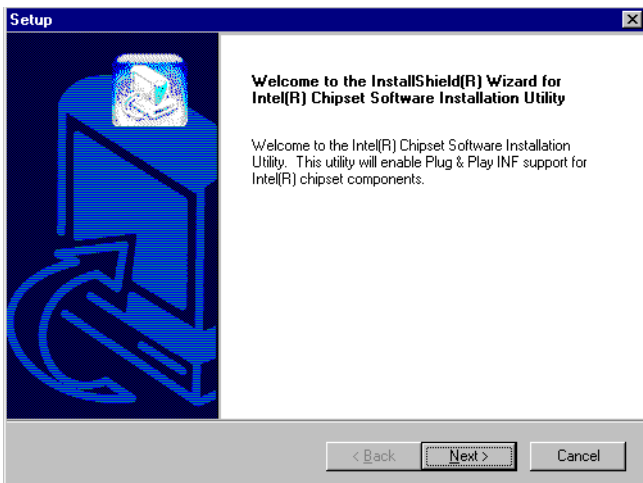

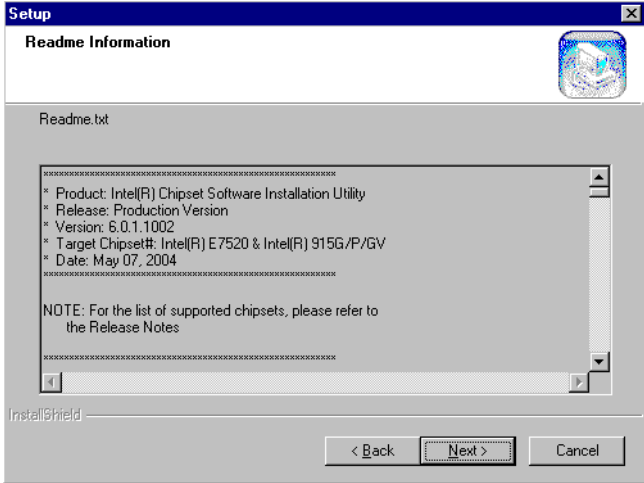

Press “Yes” to reboot.

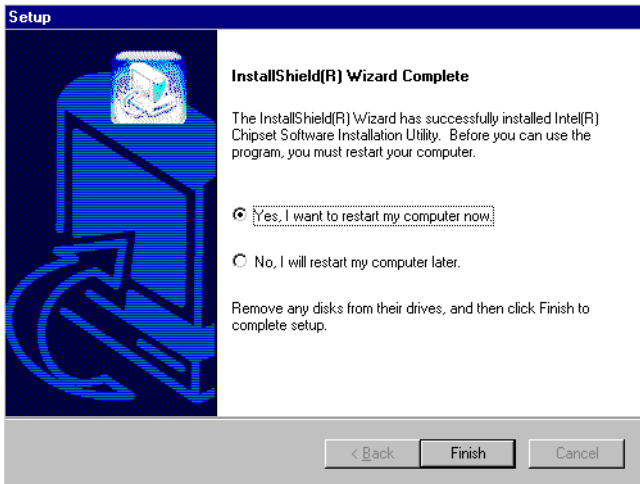

## 5.3 Further Information

---

For further information about the Chipset installation in your PCM-3386, including driver updates, troubleshooting guides and FAQ lists, visit the following web resources:

Advantech websites: [www.advantech.com](http://www.advantech.com)  
[www.advantech.com.tw](http://www.advantech.com.tw)

## **VGA/LCD Graphic**

Introduction

Installation of VGA Graphic drivers

-for Windows 98/2000/XP

Further information

# Chapter 6 VGA Graphic Setup

## 6.1 Introduction

---

The PCM-3386 has an onboard VGA/LCD interface. The specifications and features are described as follows:

### 6.1.1 Chipset

The PCM-3386 uses an Intel 852GM 7009 chipset for its graphic controller. It supports Dual Display(CRT + 36bit LVDS).

### 6.1.2 Display memory

The 852GM chip can support a dynamic frame buffer up to 64 MB shared with system memory. The VGA controller can drive CRT displays up to 1600 x 1200 at 85-Hz, and color panel displays in LVDS model with resolutions equivalent to UGXA panel resolution with frequency range from 25 MHz to 112 MHz.

### 6.1.3 Display types

CRT and panel displays can be used simultaneously. The PCM-3386 can be set in one of three configurations: CRT only, LVDS only, both CRT and LFP (LVDS). The system is initially set to simultaneous display mode - CRT and LFP (LVDS). If you want to enable other display modes, please set it up manually. Set up examples are shown in the following chapters.

### 6.1.4 Dual/Simultaneous Display

The PCM-3386 uses an Intel 852GM controller that is capable of providing simultaneous dual view display of the same content on a flat panel and CRT.

To set up dual view (simultaneous mode) under Windows 9x, Windows ME, Windows NT/2000/XP, follow these steps:

- Step 1. Open the Control panel, and select "Display", "Settings".
- Step 2. Select "Advanced"
- Step 3. Select "Graphic Properties"
- Step 4. Select "Devices" mode and click "OK"



Figure 6.1: Selecting Display Settings

## 6.2 Installation of the PCI Graphic driver

---

Complete the following steps to install the Intel extreme Chipset Graphics Driver Software. Follow the procedures in the flow chart that apply to the operating system that you are using within your PCM-3386.

- Notes:**
1. *The windows illustrations in this chapter are intended as examples only. Please follow the listed steps, and pay attention to the instructions which appear on your screen.*
  2. *For convenience, the CD-ROM drive is designated as "D" throughout this chapter.*

### 6.2.1 Installation for Windows 98/ME/2000/XP

To install Intel extreme Chipset Graphics Driver Software for Windows 98/2000/XP, please run the set up wizard "Intel(R) Extreme Graphic 2" in CD-ROM. Example of installation steps are shown as bellow:



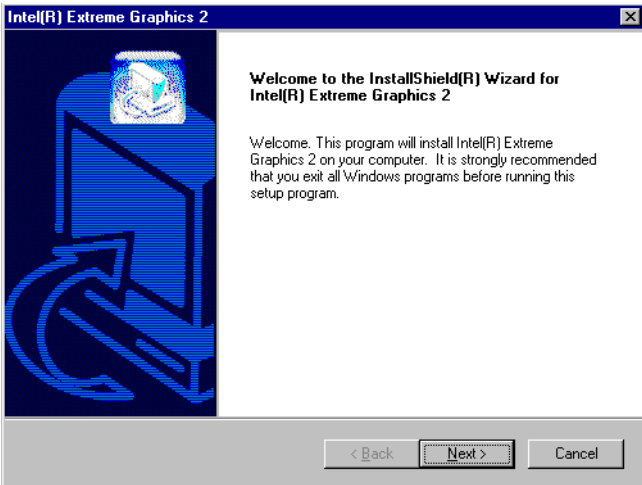
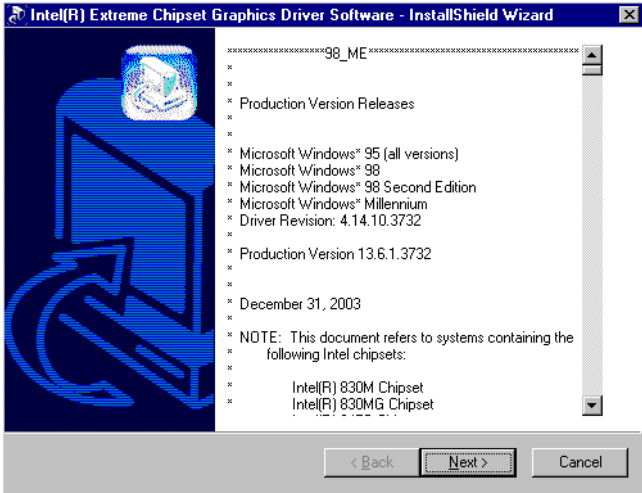

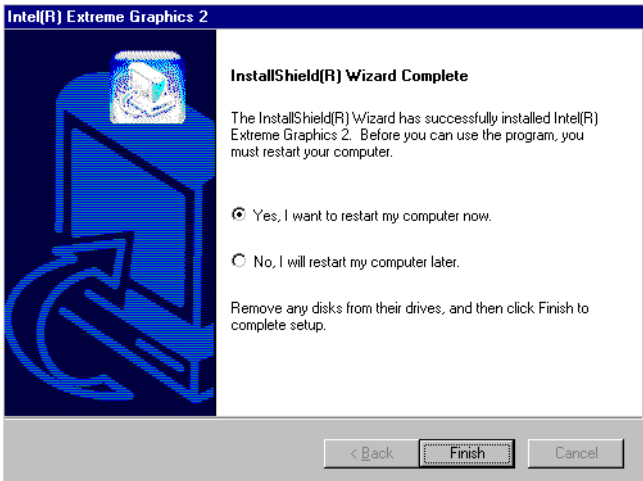
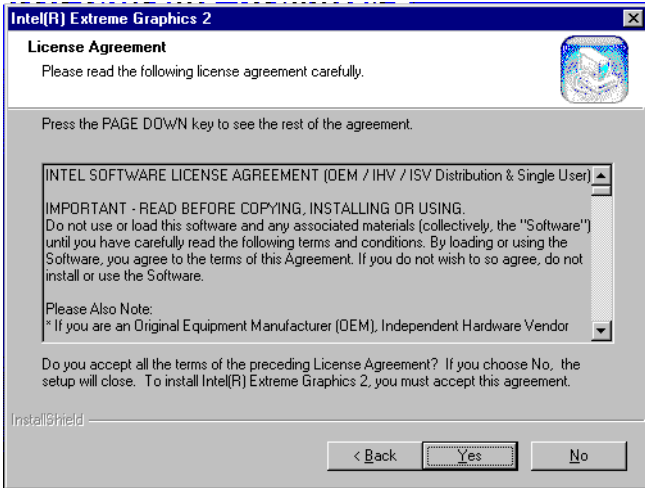

Press “Yes” to reboot.

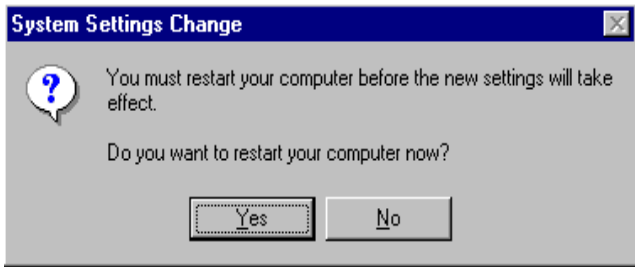

*Notes: Windows 98 Second Edition has some problems with VGA installation. The system will ask user to insert "intel Corporation Installation Disk#1" after restarting the system. To avoid the unnecessary problem, please do not install Windows 98SE.*

### 6.2.2 VGA potential problems

To adjust resolution, please follow the below steps:

1. Click on the right conner and choose Graphics Options.

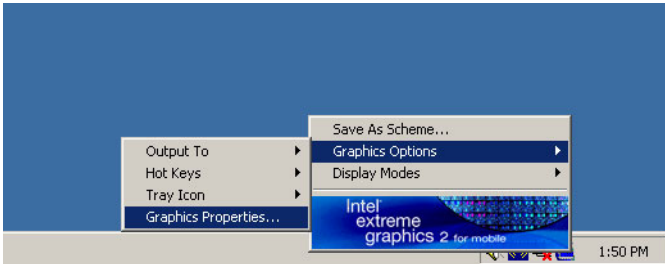

2. Then you will see the following menu.

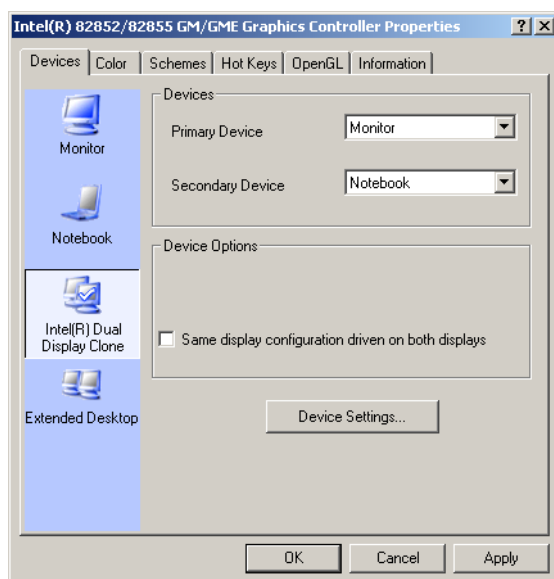

3. Choose monitor icon, then you can adjust resolution.

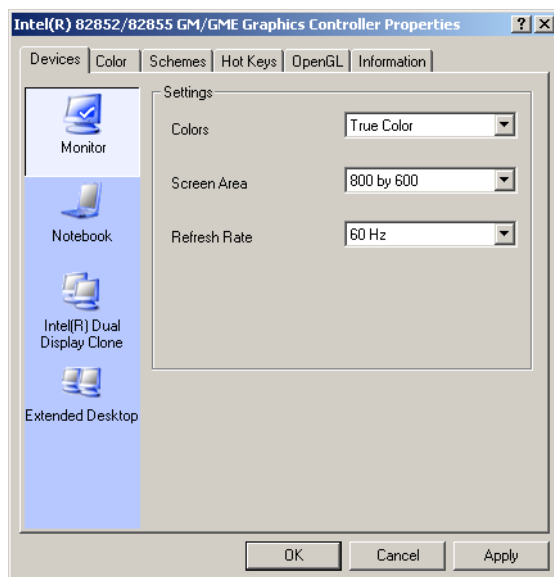

## 6.3 Further Information

---

For further information about the AGP/VGA installation in your PCM-3386, including driver updates, troubleshooting guides and FAQ lists, visit the following web resources:

Advantech websites: [www.advantech.com](http://www.advantech.com)  
[www.advantech.com.tw](http://www.advantech.com.tw)



## **Audio Setup**

The PCM-3386 is equipped with an audio interface that records and plays back CD-quality audio. This chapter provides instructions for installing the software drivers included on the audio driver diskettes.

# Chapter 7 Audio Setup

## 7.1 Introduction

---

The PCM-3386's on-board audio interface provides high-quality stereo sound and FM music synthesis (ESFM) by using the Intel ICH4 audio controller. The audio interface can record, compress, and play back voice, sound, and music with built-in mixer control.

## 7.2 Driver installation

---

### 7.2.1 Before you begin

Please read the instructions in this chapter carefully before you attempt installation. The audio drivers for the PCM-3386 board are located on the audio driver CD. Run the supplied SETUP program to install the drivers;

*Note:*

- 1. The files on the software installation diskette are compressed. Do not attempt to install the drivers by copying the files manually. You must use the supplied SETUP program to install the drivers.*

## 7.2.2 Windows 9x/2000/Me/XP drivers

Step 1. To install Audio driver for Windows 98/2000/XP, please run the set up wizard "InstallShield Wizard for Realtek AC'97 Audio" in CD-ROM. Example of installation steps is shown as below.

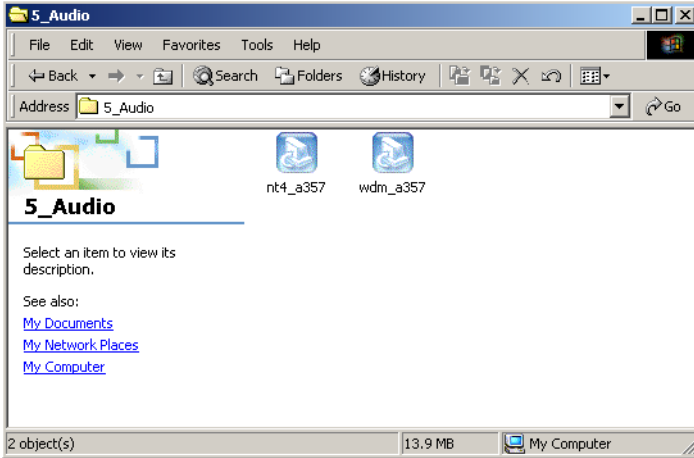

Step 2. Click "Next" to install the Realtek AC'97 Audio

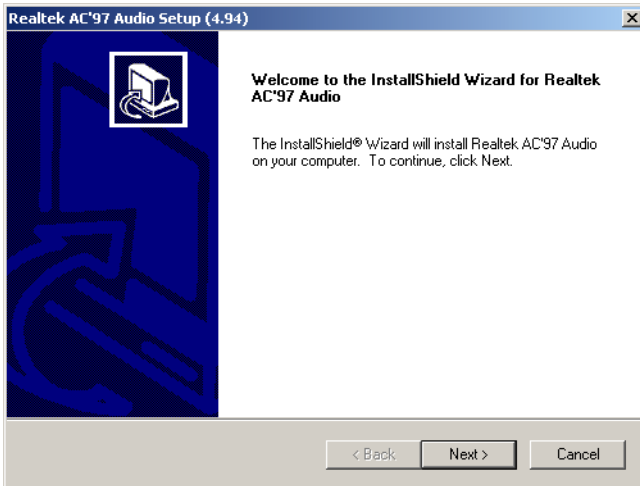

Step 3. Click “Yes” to continue the installation

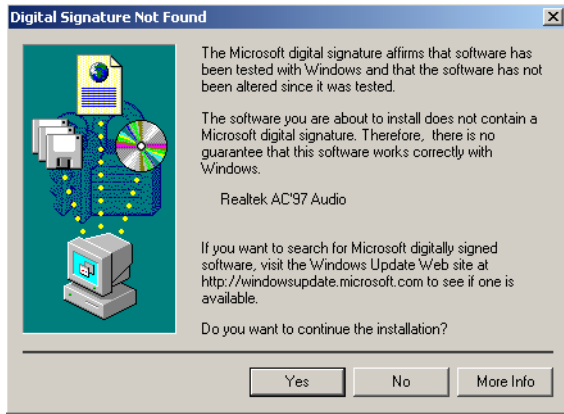

Step 4. In the following Hardware Update Wizard window, click "Finish" for Windows to complete audio driver installation.

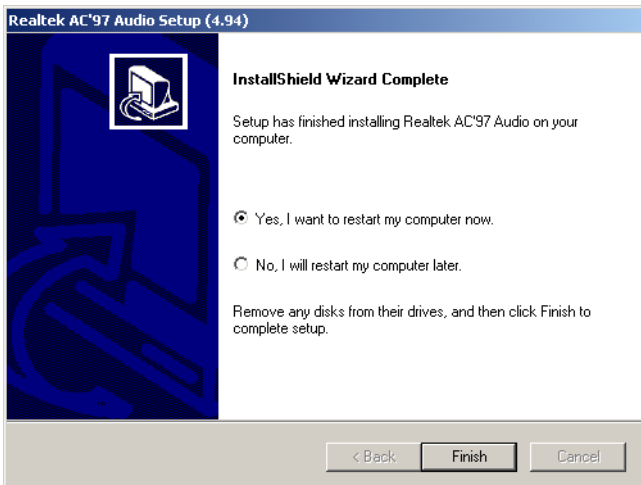

## **LAN Configuration**

- Introduction
- Features
- Installation of Ethernet Driver for
  - Windows 2000 Drivers Setup Steps
  - Windows NT Drivers Setup Steps
  - Windows Wake-on-LAN Setup

# Chapter 8 PCI Bus Ethernet Interface

## 8.1 Introduction

---

The PCM-3386 is equipped with a high-performance 32-bit Ethernet chipset which is fully compliant with IEEE 802.3 100 Mbps CSMA/CD standards. It is supported by major network operating systems. It is also both 100Base-T and 10Base-T compatible.

## 8.2 Features

---

- Intel 82562 10/100Base-T Ethernet LAN controller
- Optional Intel 82540 10/100/1000 Base-T Ethernet LAN controller
- Supports Wake-on-LAN remote control function.
- PCI Bus Master complies with PCI Rev. 2.1
- Complies with 100Base-TX, and 10Base-T applications.
- Single RJ-45 connector gives auto-detection of 10 Mbps or 100 Mbps network data transfer rates and connected cable types.
- ACPI Rev. 2.0, and Device Class Power Management Rev. 1.0.

## 8.3 Installation of Ethernet Driver

---

Before installing the Ethernet driver, note the procedures below. You must know which operating system you are using in your PCM-3386, and then refer to the corresponding installation procedure. Then just follow the steps described. You will quickly and successfully complete the installation, even if you are not familiar with instructions for Windows.

**Note:** *The windows illustrations in this chapter are examples only. You must follow the flow chart instructions and pay attention to the instructions which then appear on your screen.*

### 8.3.1 Installation for Windows 2000

**Note:** The CD-ROM drive is designated as "D" throughout this section.

1. Click "Setup" icon in path "D:\3386\LAN\"

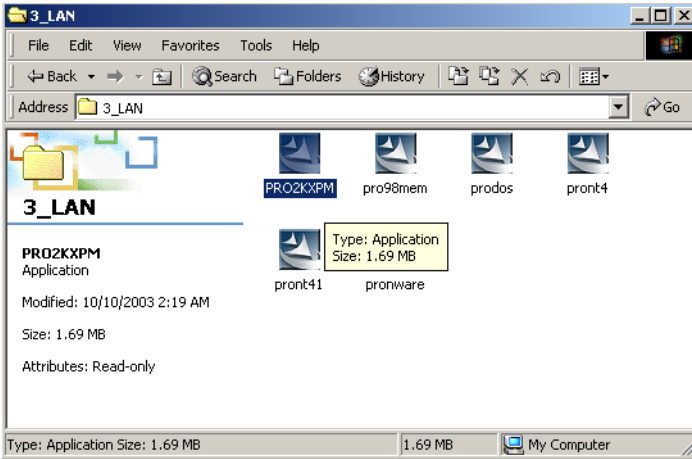

2. Choose "Accept" item and click "Next" to go next step.



3. Click "Next".

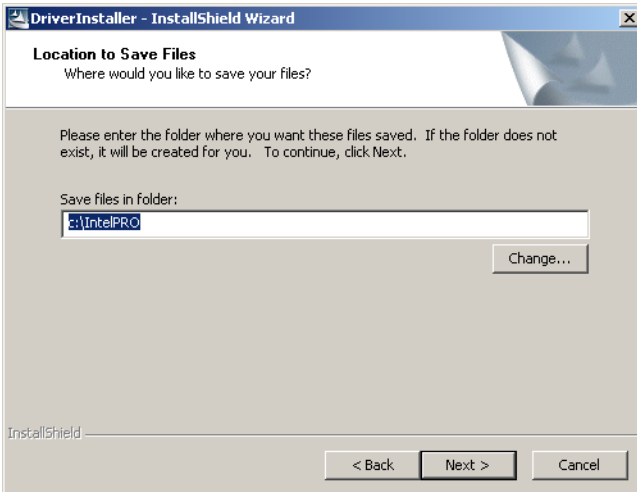

4. Click "Install" to begin the installation.



5. Click "Exit" to exit the wizard.



### 8.3.2 Installation for Windows NT

1. Select "Start", "Settings", "Control Panel" and double click "Network" icon.



2. Then this menu will show on the screen. And click "Yes" to install network driver.

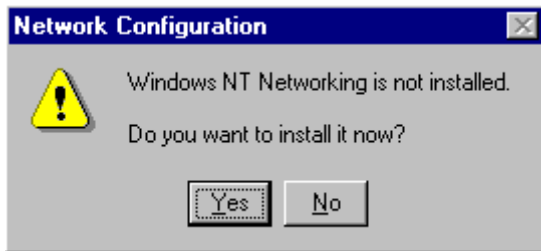

3. Select "Wired to the network" and click "Next"

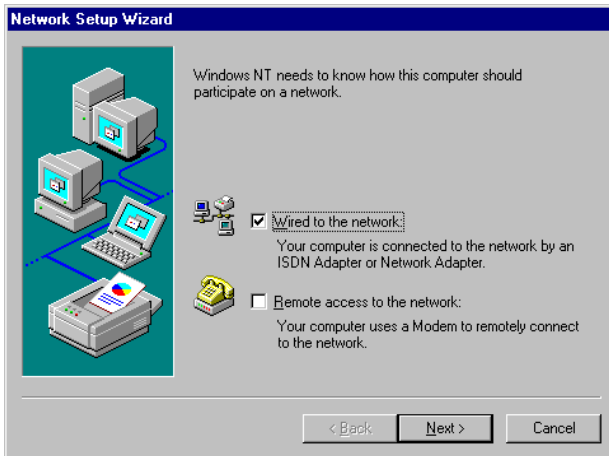

4. Click "Start Search" to search for a Network Adapter. Then click "Next" to go to the next step

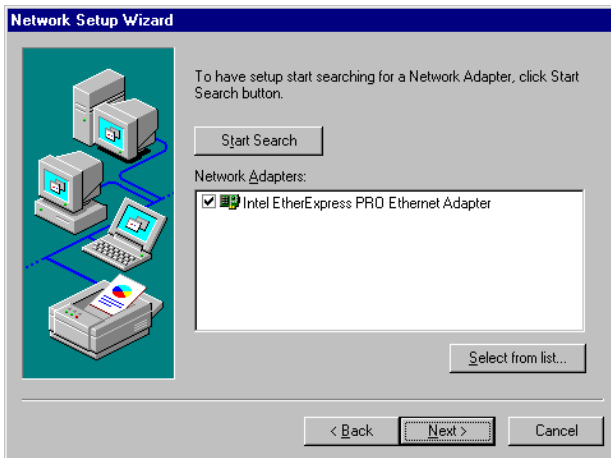

5. Base on current network environment to modify the Network Protocol then Click "Next"

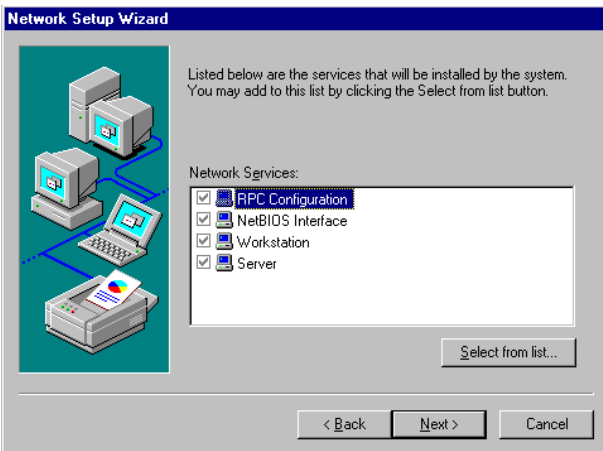
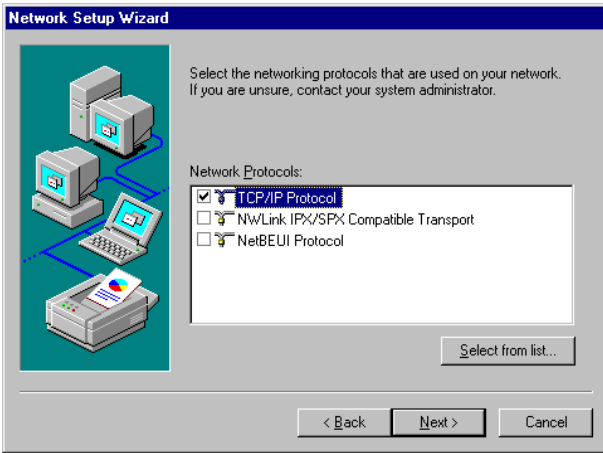

6. Click "Next" to go to next step

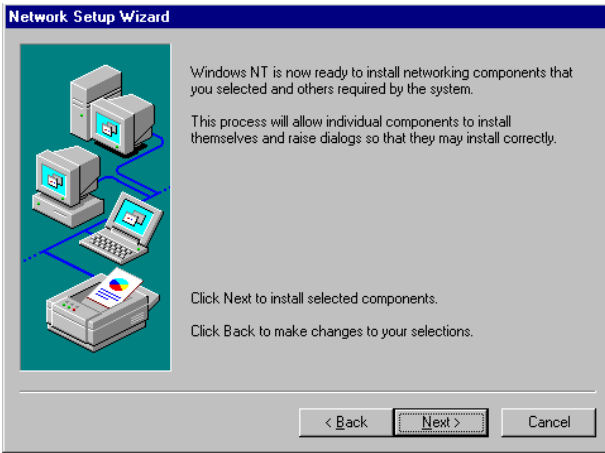

7. Click "Next" to install the Network Adapter driver.

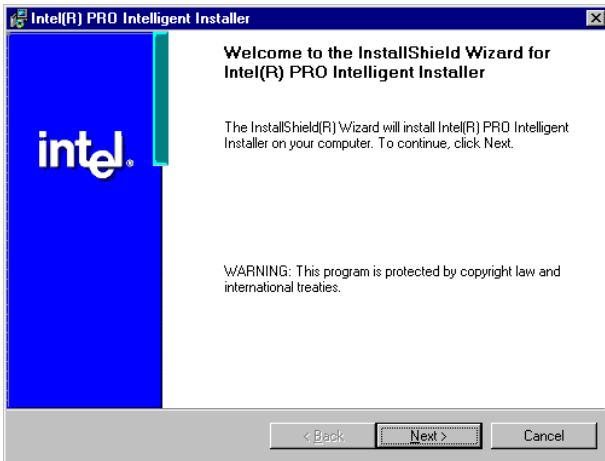

8. Check the License Agreement first then select "I accept the terms in the license agreement" and click "Next".

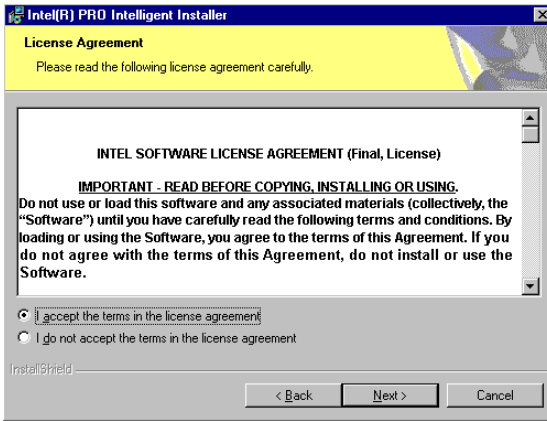

9. Select "Typical" and Click "Next".

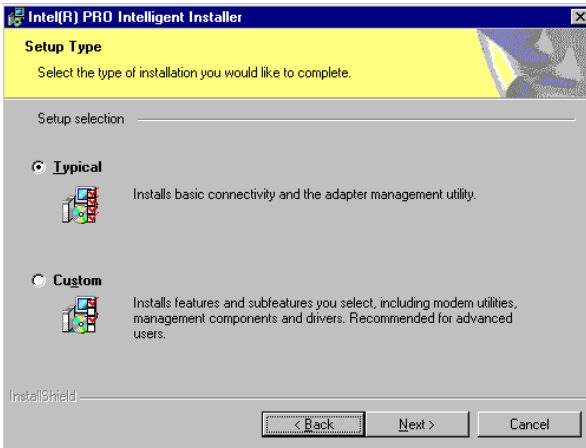

10. Click "Install" to start to install driver.

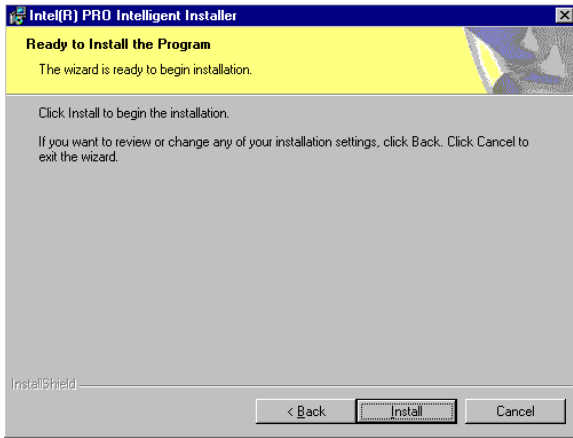

11. Click "Finish" to finish install driver.

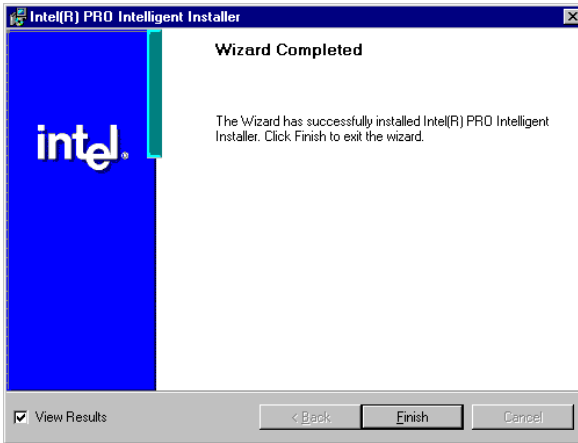

## 8.4 Further information

---

Intel website: [www.intel.com](http://www.intel.com)

Advantech websites: [www.advantech.com](http://www.advantech.com)

[www.advantech.com.tw](http://www.advantech.com.tw)



## **USB Setup**

Introduction

Installation of USB drivers

-for Windows 98/2000/XP

Further information

# Chapter 9 USB Setup

## 9.1 Introduction

---

The PCM-3386 support 6 ports USB2.0/1.1.

## 9.2 Installation of the PCI USB driver

---

- Notes:*
- 1. The windows illustrations in this chapter are intended as examples only. Please follow the listed steps, and pay attention to the instructions which appear on your screen.*
  - 2. For convenience, the CD-ROM drive is designated as "D" throughout this chapter.*

### 9.2.1 Installation for Windows 98/ME/2000/XP

The USB drivers for the PCM-3386 board are located on the USB driver CD. Example of installation steps are shown below:

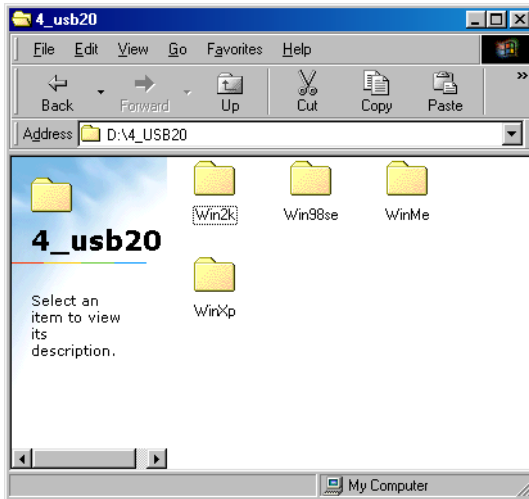

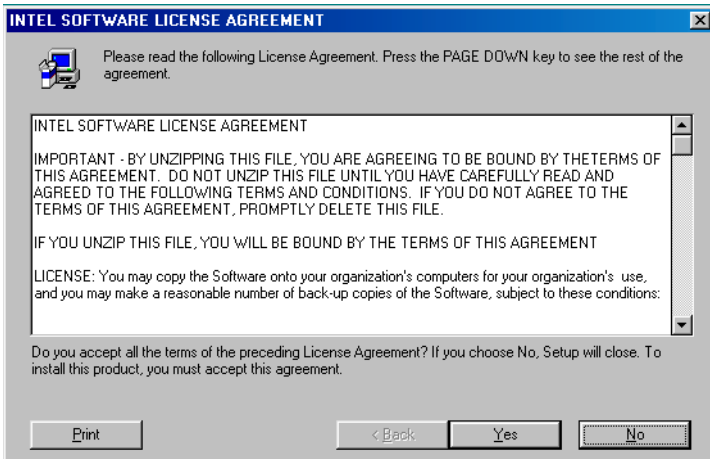

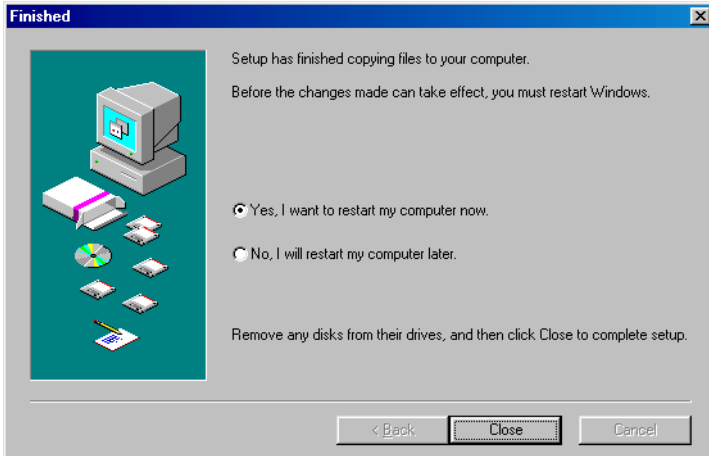

**Notes:** *Windows 98 Second Edition has some problems with USB installation. The user can install the USB driver without any problem, however, the system asks user to provide the driver after the USB device is actually inserted into the system. To avoid the unnecessary problem, please do not install Windows 98SE.*

## 9.2.2 Installation for windows 2000

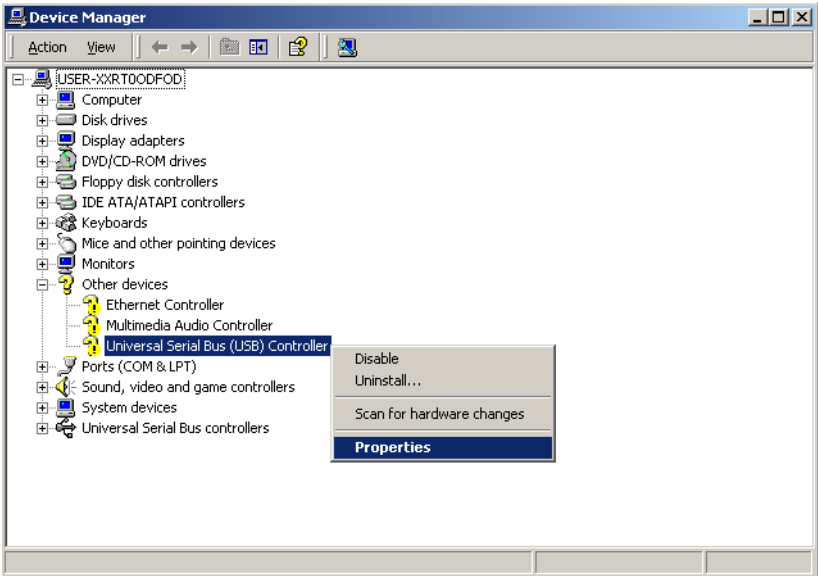

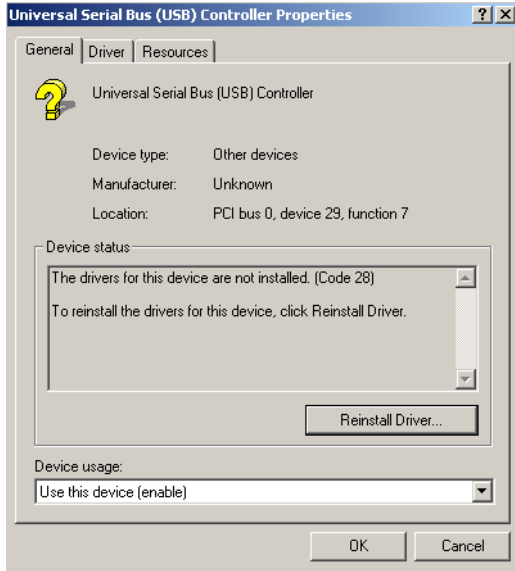

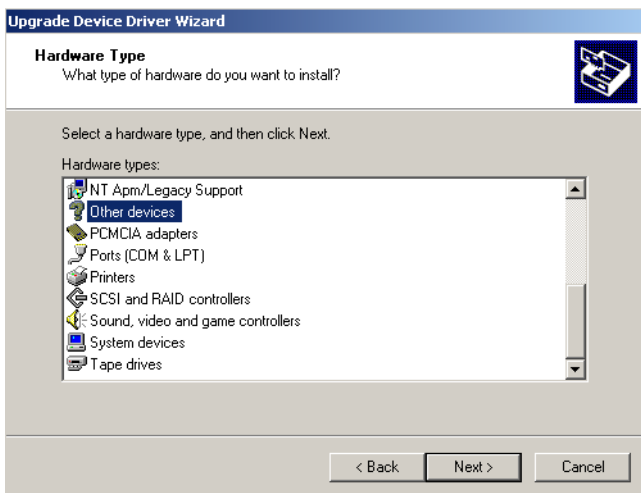

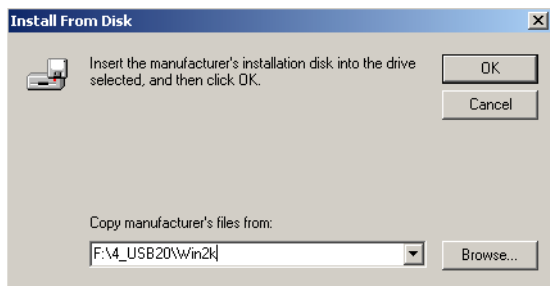
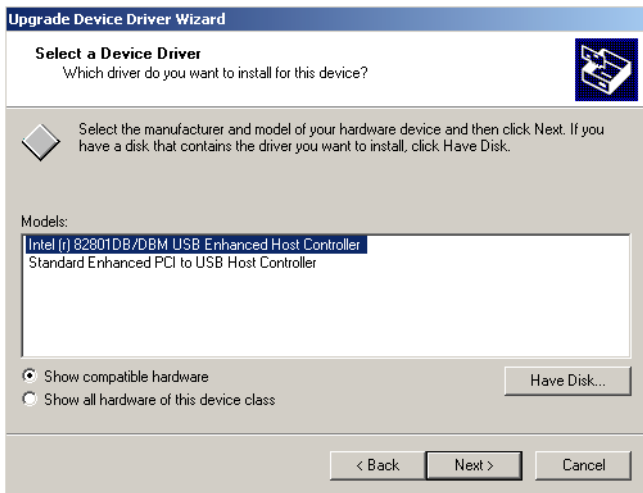

## Upgrade Device Driver Wizard

### Select a Device Driver

Which driver do you want to install for this device?



Select the manufacturer and model of your hardware device and then click Next. If you have a disk that contains the driver you want to install, click Have Disk.

Manufacturers:

(Standard USB Hub)  
Intel  
NEC

Models:

Intel PCI to USB Enhanced Host Controller

Have Disk...

< Back

Next >

Cancel

## Upgrade Device Driver Wizard

### Start Device Driver Installation

The device driver will be installed with the default settings.



The wizard is ready to install the driver for the following hardware device:



Intel PCI to USB Enhanced Host Controller

Windows will use default settings to install the software for this hardware device. To install the software for your new hardware, click Next.

< Back

Next >

Cancel



### 9.3 Further Information

---

For further information about the USB installation in your PCM-3386, including driver updates, troubleshooting guides and FAQ lists, visit the following web resources:

Advantech websites: [www.advantech.com](http://www.advantech.com)  
[www.advantech.com.tw](http://www.advantech.com.tw)

## **Programming the Watchdog Timer**

The PCM-3386 is equipped with a watchdog timer that resets the CPU or generates an interrupt if processing comes to a standstill for any reason. This feature ensures system reliability in industrial standalone or unmanned environments.

# Appendix A Programming Watchdog Timer

## A.1 Watchdog programming

---

Below is a sample of programming code for controlling the Watchdog Timer function.

-----  
Enter the extended function mode, interruptible double-write

```
MOV DX,2EH
MOV AL,87H
OUT DX,AL
OUT DX,AL
```

-----  
Configure logical device 8, configuration register CRF6

```
MOV DX,2EH
MOV AL,07H ; point to Logical Device Number Reg.
OUT DX,AL
MOV DX,2FH
MOV AL,08H ; select logical device 8
OUT DX,AL ;
MOV DX,2EH
MOV AL,30H ;Set watchdog activate or inactivate
OUT DX,AL
MOV DX,2FH
MOV AL,01H ; 01:activate 00:inactivate
OUT DX,AL ;
MOV DX,2EH
MOV AL,F5H ; Setting counter unit is second
OUT DX,AL
```

```
MOV DX,2FH
MOV AL,00H
OUT DX,AL;
MOV DX,2EH
MOV AL,F6H
OUT DX,AL
MOV DX,2FH
MOV AL,05H ; Set 5 seconds
OUT DX,AL
;-----
; Exit extended function mode |
;-----
MOV DX,2EH
MOV AL,AAH
OUT DX,AL
```



## Pin Assignments

This appendix provides specialized information regarding:

- LCD Inverter Connector
- Battery Connector
- Front Panel Connector
- Power Connector
- LAN Connector
- Fan Connector(5V Only)
- Audio Connector(Line Out)
- KB/MS Connector
- 2ch LVDS Connector
- IDE 44pin connector
- LPT Connector
- ATX Ctrl Connector
- Audio Connector
- CRT Connector
- USB Connector
- COM Port Connector

# Appendix B Pin Assignments

## B.1 LCD Inverter Connector (CN1)

---

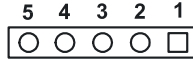

---

*Table B.1: LCD Inverter Connector(CN1)*

---

Pin	Signal
1	+12V
2	BKLTEN
3	GND
4	VBR
5	VCC

## B.2 Battery Connector (CN2)

---



---

*Table B.2: Battery Connector (CN2)*

---

Pin	Signal
1	+3V
2	GND

### B.3 Front Panel connector (CN6)

---

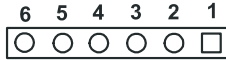
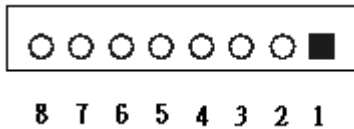

*Table B.3: Front Panel connector (CN6)*

Pin	Signal
1	PS_IN-
2	PS_IN+
3	RESET_IN-
4	RESET_IN+
5	BUZZER-
6	BUZZER+

### B.4 Power Connector(CN8)

---

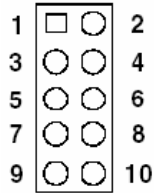

*Table B.4: Power Connector (CN8)*

Pin	Signal
1	VCC
2	VCC
3	VCC
4	GND
5	GND
6	GND
7	GND
8	VCC_12V

## B.5 LAN Connector (CN9)

---



*Table B.5: LAN Connector(CN9)*

Pin	Signal	Pin	Signal
1	LAN Vcc	2	LED2-
3	Rx+	4	Rx-
5	LED1-	6	LAN GND
7	N.C.	8	LAN GND
9	Tx+	10	Tx-

## B.6 Fan Connector(5V Only) (CN10)

---

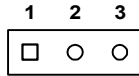

*Table B.6: Fan Connector(5V Only) (CN10)*

Pin	Signal
1	Vcc
2	GND

## B.7 Audio Connector(Line Out) (CN11)

---



---

*Table B.7: Audio Connector(Line Out)(CN11)*

---

Pin	Signal
1	LineOut_R
2	GND
3	LineOut_L

---

## B.8 KB/MS Connector (CN4)

---

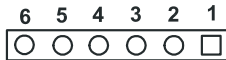

---

*Table B.8: KB/MS connector (CN4)*

---

Pin	Signal
1	KB CLOCK
2	KB DATA
3	MS CLOCK
4	GND
5	KB_VCC
6	MS DATA

---

## B.9 2ch LVDS Connector (CN12)

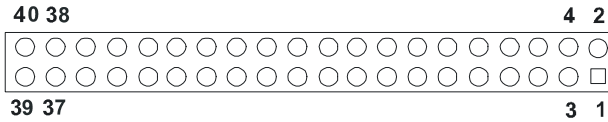

**Table B.9: 2ch LVDS Connector (CN12)**

Pin	Signal	Pin	Signal
1	VDD_Safe	2	VDD_Safe
3	GND	4	GND
5	VDD_Safe	6	VDD_Safe
7	1st LVDS YA-[0,1,2,3]	8	2nd LVDS YA-[0,1,2,3]
9	1st LVDS YA+[0,1,2,3]	10	2nd LVDS YA+[0,1,2,3]
11	GND	12	GND
13	1st LVDS YA-[0,1,2,3]	14	2nd LVDS YA-[0,1,2,3]
15	1st LVDS YA+[0,1,2,3]	16	2nd LVDS YA+[0,1,2,3]
17	GND	18	GND
19	1st LVDS YA-[0,1,2,3]	20	2nd LVDS YA-[0,1,2,3]
21	1st LVDS YA+[0,1,2,3]	22	2nd LVDS YA+[0,1,2,3]
23	GND	24	GND
25	1st LVDS Clk-	26	2nd LVDS Clk-
27	1st LVDS Clk	28	2nd LVDS Clk+
29	GND	30	GND
31	LVDS_DCLK	32	LVDS_DDAT
33	GND	34	GND
35	1st LVDS YA-[0,1,2,3]	36	2nd LVDS YA-[0,1,2,3]
37	1st LVDS YA+[0,1,2,3]	38	2nd LVDS YA+[0,1,2,3]
39	N.C.	40	N.C.

## B.10 IDE 44pin Connector (CN5)

*Table B.10: IDE 44pin connector (CN5)*

Pin	Signal	Pin	Signal
1	RESET#	2	GND
3	IDE_D[7:0}	4	IDE_D[8:15}
5	IDE_D[7:0}	6	IDE_D[8:15}
7	IDE_D[7:0}	8	IDE_D[8:15}
9	IDE_D[7:0}	10	IDE_D[8:15}
11	IDE_D[7:0}	12	IDE_D[8:15}
13	IDE_D[7:0}	14	IDE_D[8:15}
15	IDE_D[7:0}	16	IDE_D[8:15}
17	IDE_D[7:0}	18	IDE_D[8:15}
19	GND	20	N.C.
21	IDE_DREQ	22	GND
23	IDE_IOW#	24	GND
25	IDE_IOR#	26	GND
27	IDE_IORDY	28	CSEL
29	IDE_DACK#	30	GND
31	IDE_IRQ	32	N.C.
33	IDE_A[2:0]	34	IDE_PDIAG#
35	IDE_A[2:0]	36	IDE_A[2:0]
37	IDE_CS[0,1]#	38	IDE_CS[0,1]#
39	IDE_DASP#	40	GND
41	VCC	42	VCC
43	GND	44	N.C.

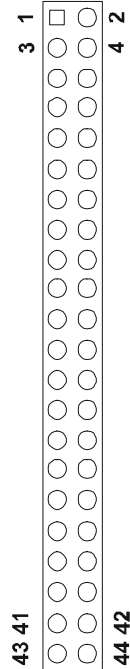

## B.11 LPT Connector (CN19)

*Table B.11: LPT Connector (CN19)*

Pin	Signal	Pin	Signal
1	LPT_STB#_O	2	LPT_AFD#
3	LPT_PPD[0,1,2,3,4,5,6,7]	4	LPT_ERR#
5	LPT_PPD[0,1,2,3,4,5,6,7]	6	LPT_INIT#
7	LPT_PPD[0,1,2,3,4,5,6,7]	8	LPT_SLIN#
9	LPT_PPD[0,1,2,3,4,5,6,7]	10	GND
11	LPT_PPD[0,1,2,3,4,5,6,7]	12	GND
13	LPT_PPD[0,1,2,3,4,5,6,7]	14	GND
15	LPT_PPD[0,1,2,3,4,5,6,7]	16	GND
17	LPT_PPD[0,1,2,3,4,5,6,7]	18	GND
19	LPT_ACK#	20	GND
21	LPT_BUSY	22	GND
23	LPT_PE	24	GND
25	LPT_SLCT	26	GND

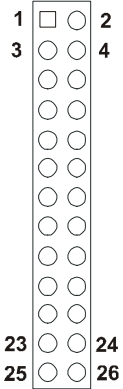

## B.12 ATX AUX Connector (CN13)

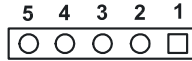

*Table B.12: ATX Ctrl Connector (CN13)*

Pin	Signal
1	VccSB
2	N.C.
3	PS_ON#

## B.13 Audio Line-in/Mic Connector (CN15)

---

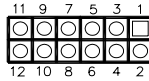

*Table B.13: Audio Connector (CN15)*

Pin	Signal
1	LineIn_R
2	GND
3	LineIn_L
4	GND
5	Mic_In

## B.14 CRT Connector (CN14)

---

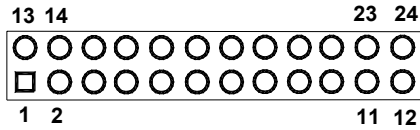

*Table B.14: CRT Connector (CN14)*

Pin	Signal	Pin	Signal
1	GND	3	VGA_G
2	VGA_R	4	VGA_B
5	GND	6	
7	VGA_DDAT	8	VGA_DCLK
9	GND	10	VGA_HS
11	VGA_VS	12	GND

## B.15 USB Connector (CN18)

---

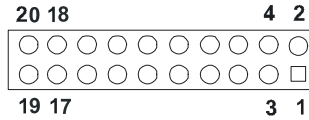

**Table B.15: USB Connector (CN18)**

Pin	Signal	Pin	Signal
1	VCC_USBP1	2	VCC_USBP1
3	USB_PP0N/P	4	USB_PP1N/P
5	USB_PP0N/P	6	USB_PP1N/P
7	GND	8	GND
9	VCC_USBP2	10	VCC_USBP2
11	USB_PP2N/P	12	USB_PP3N/P
13	USB_PP2N/P	14	USB_PP3N/P
15	GND	16	GND
17	VCC_USBP3	18	VCC_USBP3
19	USB_PP4N/P	20	USB_PP5N/P
21	USB_PP4N/P	22	USB_PP5N/P
23	GND	24	GND

## B.16 COM Port Connector (CN17)

---



**Table B.16: COM Port Connector (CN17)**

Pin	Signal	Pin	Signal
1	COM1_DCD#	2	COM1_DSR#
3	COM1_RX#	4	COM1_RTS#
5	COM1_TX#	6	COM1_CTS#
7	COM1_DTR#	8	COM1_RI
9	GND	10	GND
11	COM2_DCD#	12	COM2_DSR#
13	COM2_RX#	14	COM2_RTS#
15	COM2_TX#	16	COM2_CTS#
17	COM2_DTR#	18	COM2_RI
19	GND	20	GND



## **System Assignments**

This Appendix contains information of a detailed nature: It includes:

- System I/O ports
- 1st MB memory map
- DMA channel assignments
- Interrupt assignments

# Appendix C System Assignments

## C.1 System I/O Ports

---

*Table C.1: System I/O Ports*

---

Addr. range (Hex)	Device
000-01F	DMA controller
020-021	Interrupt controller 1, master
040-05F	8254 timer
060-06F	8042 (keyboard controller)
070-07F	Real-time clock, non-maskable interrupt (NMI) mask
080-09F	DMA page register
0A0-0BF	Interrupt controller 2
0C0-0DF	DMA controller
0F0	Clear math co-processor
0F1	Reset math co-processor
0F8-0FF	Math co-processor
1F0-1F8	Fixed disk
170- 178	Fixed disk (2nd IDE)
200-207	Reserved (Game I/O)
278-27F	Parallel printer port 2 (LPT 3)
2E8-2EF	Series port 4
2F8-2FF	Serial port 2
300-31F	Prototype card
360-36F	Reserved
378-37F	Parallel printer port 1 (LPT 2)
380-38F	SDLC, bisynchronous 2
3A0-3AF	Bisynchronous 1
3B0-3BF	Monochrome display and printer adapter (LPT1)
3C0-3CF	Reserved
3D0-3DF	Color/graphics monitor adapter
3E8-3EF	Series port 3
3F0-3F7	Diskette controller
3F8-3FF	Serial port 1

---

\* PNP audio I/O map range from 220 ~ 250H (16 bytes)  
MPU-401 select from 300 ~ 330H (2 bytes)

## C.2 1st MB memory map

---

*Table C.2: 1st MB memory map*

Addr. range (Hex)	Device
F0000h - FFFFFh	System ROM
*CC000h - EFFFFh	Unused (reserved for Ethernet ROM)
C0000h - CBFFFh	Expansion ROM (for VGA BIOS)
B8000h - BFFFFh	CGA/EGA/VGA text
B0000h - B7FFFh	Unused
A0000h - AFFFFh	EGA/VGA graphics
00000h - 9FFFFh	Base memory

\* If Ethernet boot ROM is disabled (Ethernet ROM occupies about 16 KB)

\* E0000 - EFFFF is reserved for BIOS POST

## C.3 DMA channel assignments

---

*Table C.3: DMA channel assignments*

Channel	Function
0	Available
1	Reserved (audio)
2	Floppy disk (8-bit transfer)
3	Available (parallel port)
4	Cascade for DMA controller 1
5	Available
6	Available
7	Available

\* Audio DMA select 1, 3, or 5

\*\* Parallel port DMA select 1 (LPT2) or 3 (LPT1)

## C.4 Interrupt assignments

---

*Table C.4: Interrupt assignments*

<b>Interrupt#</b>	<b>Interrupt source</b>
IRQ 0	Interval timer
IRQ 1	Keyboard
IRQ 2	Interrupt from controller 2 (cascade)
IRQ 3	COM2
IRQ 4	COM1
IRQ 5	COM4
IRQ 6	FDD
IRQ 7	LPT1
IRQ 8	RTC
IRQ 9	Reserved (audio)
IRQ 10	COM3
IRQ 11	Reserved for watchdog timer
IRQ 12	PS/2 mouse
IRQ 13	INT from co-processor
IRQ 14	Primary IDE
IRQ 15	Secondary IDE for CFC

\* Ethernet interface IRQ select: 9, 11, 15

\* PNP audio IRQ select: 9, 11, 15

\* PNP USB IRQ select: 9, 11, 15

\* PNP ACPI IRQ select: 9, 11, 15

Appendix

**D**

## **Mechanical Drawings**

# Appendix D Mechanical Drawings

## D.1 Mechanical Drawings

---

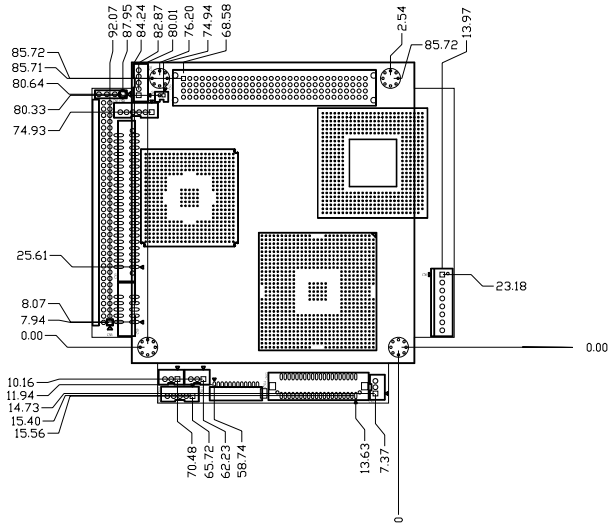

*Figure D.1: PCM-3386 Mech Drawing (component side)*

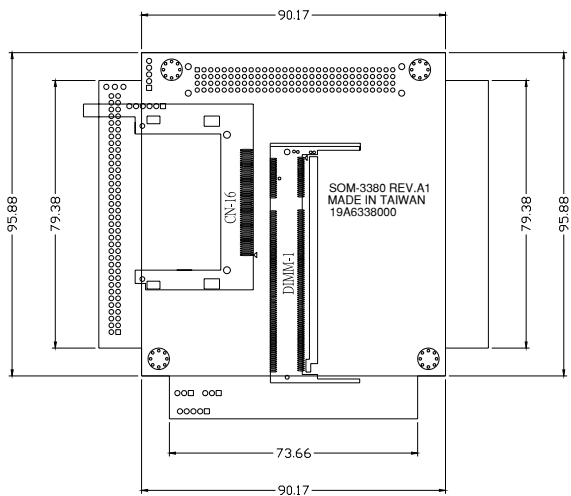

**Figure D.2: PCM-3386 Mech Drawing (solder side)**

