

PCM-3362

Intel® Atom™ N450 PC/104-Plus SBC, CRT, LVDS, LAN, USB, COM, SATA, On-board Flash

NEW



Features

- Intel® Atom™ N450 1.66 GHz Processor and DDR2 667 SDRAM up to 2 GB
- Supports extended temperature -40 ~ 85° C
- Standard 96 x 90 mm dimension and PC/104-Plus expansion connector
- On board 2 GB flash (4 GB optional)
- Supports embedded software APIs and Utilities

Software APIs:



Utilities:



Specifications

Processor System	CPU	Intel Atom N450 1.66 GHz
	Front Side Bus	667 MHz
	Frequency	1.66 GHz
	L2 Cache	512 KB
	System Chipset	Intel Atom N450 + ICH8M
	BIOS	AMI 16 Mbit
Memory	Technology	DDR2 667 MHz
	Max. Capacity	2 GB
	Socket	1 x 200-pin SODIMM
Display	Chipset	Intel Atom N450 1.66 GHz
	VRAM	Shared system memory up to 224 MB
	Graphic Engine	Intel Gen 3.5 DX9, MPEG2 Decode in HW Embedded Gen3.5+ GFX Core
	LVDS	Single channel 18-bit LVDS up to WXGA 1366 x 768
	CRT	Supports up to SXGA 1400 x 1060 @ 60 Hz
	Dual Display	CRT+LVDS
Ethernet	Speed	10/100/1000 Mbps
	Controller	Intel 82567V
	Connector	Pin header
Watchdog Timer		Output System reset Programmable 1 ~ 255 sec
Storage	SATA	1
	On board Flash	2 GB
Internal I/O	USB	4 x USB 2.0
	Serial	2 RS-232, 1 RS-422/485
	KB/Mouse	1
	GPIO	8-bit general purpose input/output
	I²C	1
Expansion	PC/104-Plus slot	1
Power	Power Type	AT/ATX
	Power Supply Voltage	5V only to boot up (12 V is optional for LCD inverter and add on card)
	Power Consumption (Typical)	+5 V @ 2 A, +12 V @ 5mA
	Power Consumption (Max, test in HCT)	+5 V @ 2.37 A, +12 V @ 7mA
	Battery	Lithium 3 V / 210 mAH
Environment	Operation	0 ~ 60° C (32 ~ 140° F) (operation humidity: 40° C @ 85% RH non-condensing)
	Non-Operation	-40° C ~ 85° C and 60° C @ 95% RH non-condensing
Physical Characteristics	Dimensions (L x W)	96 x 90 mm (3.8" x 3.5")
	Weight	0.162 kg (0.357 lb) (with heat-sink)

Board Diagram

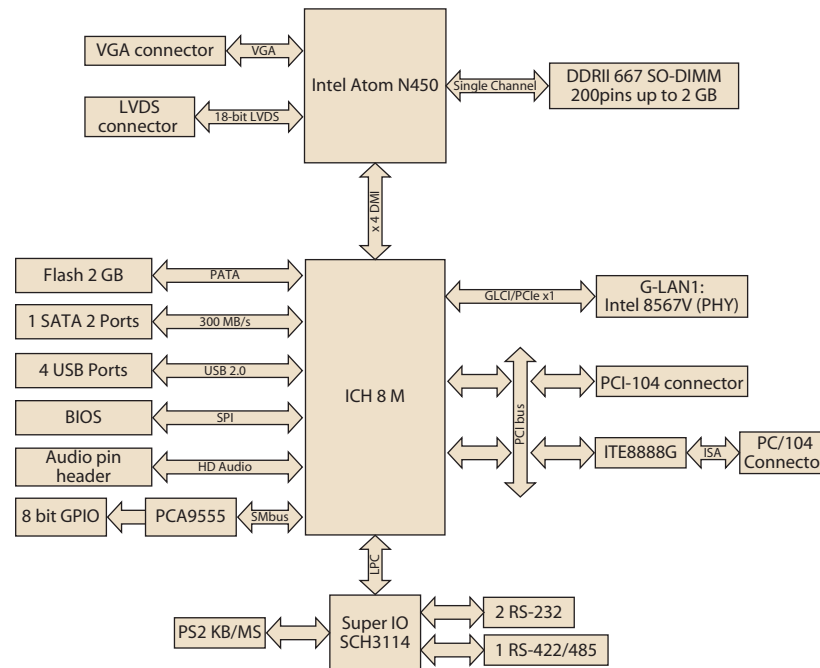

Ordering Information

Part No.	CPU	Chipset	On board flash	CRT	Memory	LVDS	LAN	USB2.0	RS-232	RS-422/485	Thermal Solution	Operating Temp.	Embedded OS
PCM-3362N-S6A1E	Atom N450	ICH8M	2 GB	Yes	SO-SIMM	18-bit	1 GbE	4	2	1	Passive	0 ~ 60° C	Optional
PCM-3362Z-1GS6A1E	Atom N450	ICH8M	2 GB	Yes	1 GB bundle	18-bit	1 GbE	4	2	1	Passive	-20 ~ 80° C	Optional
PCM-3362Z2-1GS6A1E	Atom N450	ICH8M	2 GB	Yes	1 GB bundle	18-bit	1 GbE	4	2	1	Passive	-40 ~ 85° C	Optional

Note: Wide temp version has been bundled with extended temperature grade memory module

Packing List

Part No.	Description	Quantity
	PCM-3362 SBC	
	Startup Manual	
	Utility CD	
1700000898	VGA cable D-SUB 15P(F)/12P-1.25 mm15 cm	x1
1700003491	AT power cable 1 x 8P-2.0/B4P-5.08 x 2 15 cm	x1
1700060202	Cable 6P-6P-6P PS/2 KB & Mouse 20 cm	x1
1703040157	RS-422/485 W/D-SUB COM 4P 15 cm	x1
1703060053	PS2 Cable 6P (MINI-DIN)-6P (Wafer 2.0 mm) 6 cm	x1
1700002332	ATX power cable 20P-13P/8P/3P/3P 13 cm	x1
1703100260	USB cable 2port 2.0 mm pitch w/ bracket 26 cm	x1
1700071000	SATA data cable 7p 100 cm	x1
1703150102	SATA power cable B4P-5.08/SATA 15P 10 cm	x1
1701200220	RS-232 x 2 ports 2.0 mm 22 cm	x1
1700017863	LAN cable RJ45/2 x 5P-2.0 15 cm	x1
9660104000	PC/104 screw and copper post package	x1

Optional Items

Part No.	Description
1960047106T001	Heat spreader (79.66 x 77.98 x 10.32 mm) of PCM-3362
1653130421	PCI-104 connector 120pin (Long pin)
165313222B	PC/104 connector 64pin (Long pin)
165312022B	PC/104 connector 40pin (Long pin)

Embedded OS/API

Embedded OS/API	Description
WinCE 6.0	TBD
Win XPE	2070009030: XPE WES2009 Luna Pier V4.0 ENG 2070009031: XPE WES2009 Luna Pier V4.0 MUI24
Software API	205E362000: SUSI 3.0 SW API for PCM-3362 B:20091015 XP

Value-Added Software Services

Software API: An interface that defines the ways by which an application program may request services from libraries and/or operating systems. Provides not only the underlying drivers required but also a rich set of user-friendly, intelligent and integrated interfaces, which speeds development, enhances security and offers add-on value for Advantech platforms. It plays the role of catalyst between developer and solution, and makes Advantech embedded platforms easier and simpler to adopt and operate with customer applications.

Software APIs

Control



GPIO

General Purpose Input/Output is a flexible parallel interface that allows a variety of custom connections. It allows users to monitor the level of signal input or set the output status to switch on/off a device. Our API also provides Programmable GPIO, which allows developers to dynamically set the GPIO input or output status.



SMBus

SMBus is the System Management Bus defined by Intel® Corporation in 1995. It is used in personal computers and servers for low-speed system management communications. The SMBus API allows a developer to interface a embedded system environment and transfer serial messages using the SMBus protocols, allowing multiple simultaneous device control.



I2C

I2C is a bi-directional two wire bus that was developed by Philips for use in their televisions in the 1980s. The I2C API allows a developer to interface with an embedded system environment and transfer serial messages using the I2C protocols, allowing multiple simultaneous device control.

Display



Brightness Control

The Brightness Control API allows a developer to interface with an embedded device to easily control brightness.



Backlight

The Backlight API allows a developer to control the backlight (screen) on/off in an embedded device.

Monitor



Watchdog

A watchdog timer (WDT) is a device that performs a specific operation after a certain period of time if something goes wrong and the system does not recover on its own. A watchdog timer can be programmed to perform a warm boot (restarting the system) after a certain number of seconds.



Hardware Monitor

The Hardware Monitor (HWM) API is a system health supervision API that inspects certain condition indexes, such as fan speed, temperature and voltage.



Hardware Control

The Hardware Control API allows developers to set the PWM (Pulse Width Modulation) value to adjust fan speed or other devices; it can also be used to adjust the LCD brightness.

Power Saving



CPU Speed

Make use of Intel SpeedStep technology to reduce power consumption. The system will automatically adjust the CPU Speed depending on system loading.



System Throttling

Refers to a series of methods for reducing power consumption in computers by lowering the clock frequency. These APIs allow the user to lower the clock from 87.5% to 12.5%.

Software Utilities

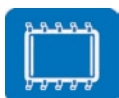

BIOS Flash

The BIOS Flash utility allows customers to update the flash ROM BIOS version, or use it to back up current BIOS by copying it from the flash chip to a file on customers' disk. The BIOS Flash utility also provides a command line version and API for fast implementation into customized applications.



Embedded Security ID

The embedded application is the most important property of a system integrator. It contains valuable intellectual property, design knowledge and innovation, but it is easily copied! The Embedded Security ID utility provides reliable security functions for customers to secure their application data within embedded BIOS.



Monitoring

The Monitoring utility allows the customer to monitor system health, including voltage, CPU and system temperature and fan speed. These items are important to a device; if critical errors happen and are not solved immediately, permanent damage may be caused.



eSOS

The eSOS is a small OS stored in BIOS ROM. It will boot up in case of a main OS crash. It will diagnose the hardware status, and then send an e-mail to a designated administrator. The eSOS also provides remote connection: Telnet server and FTP server, allowing the administrator to rescue the system.



Flash Lock

Flash Lock is a mechanism that binds the board and CF card (SQFlash) together. The user can "Lock" SQFlash via the Flash Lock function and "Unlock" it via BIOS while booting. A locked SQFlash cannot be read by any card reader or boot from other platforms without a BIOS with the "Unlock" feature.