

MIC-3301

6U-sized Rear Transition Board for CompactPCI

1. Introduction

The MIC-3301 is a CompactPCI 6U-sized rear transition board. It provides access to the rear panel for the I/O function on Advantech's CompactPCI CPU board. An on-board 2.5" hard disk drive can be installed on the MIC-3301 by using a mounting bracket shipped with the MIC-3301. The MIC-3301 also supports a CompactFlash™ card for diskless operation. The MIC-3301 is designed only for 6U CompactPCI system with rear-panel slots.

2. Specification

2.1 Standard functions

- ❑ **Serial port:** One RS-232 port
- ❑ **Keyboard connector:** One 6-pin mini-DIN connector on rear panel
- ❑ **Mouse connector:** One 6-pin mini-DIN connector on rear panel
- ❑ **EIDE interface:** Handles two on-board IDE channels, connects up to four IDE drives
- ❑ **FDD interface:** Supports one on-board floppy connector, connects up to two floppy disk drives
- ❑ **CompactFlash™ interface:** Supports one on-board CompactFlash™ socket

2.2 Mechanical and environmental specifications

- ❑ **Board size:** 233.35 x 80 mm (6U), two-slot (8TE) wide
- ❑ **Max. power requirements:** +5 V (4.75 ~ 5.25 V) @ 1 A
- ❑ **Operating temperature:** 0 ~ 60 °C (32 ~ 140 °F)
- ❑ **Storage temperature:** -20 ~ 70 °C (-4 ~ 158 °F)
- ❑ **Humidity (operating and storage):** 5 ~ 95% (non-condensing)
- ❑ **Board weight:** 0.4 Kg
- ❑ **Shock:** 20 G (operating); 50 G (storage/transit)
- ❑ **Random vibration:** 1.5 Grms

3. Board Layout

Table 3-1: MIC-3301 connector and jumper descriptions

Number	Function
JP1	CompactFlash™ master/slave selection
CN8	Floppy disk connector
CN9	PS/2 mouse connector
CN10	COM1 port
CN11	44-pin primary IDE connector
CN12	40-pin secondary IDE connector
CN13	CompactFlash™ socket
CN21	PS/2 keyboard connector
CN24	40-pin primary IDE connector

Note:

The CompactFlash™ interface (CN13) uses a primary IDE channel. Users need to set it as master or slave via jumper JP1 when another device is connected on the primary IDE channel as well.

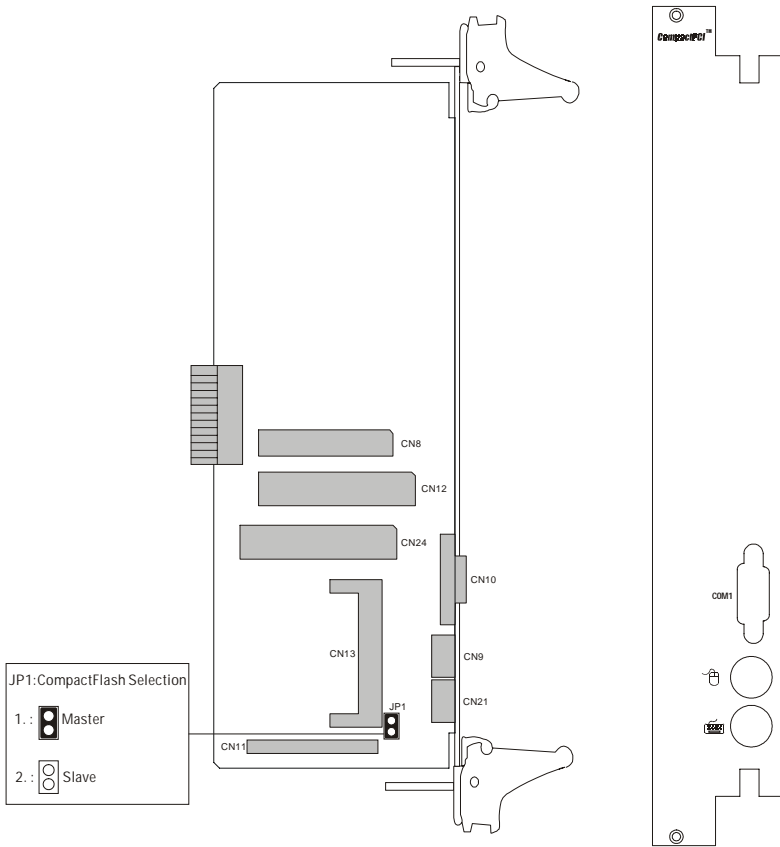

Figure 3-1: MIC-3301 connector and jumper locations

4. HDD Installation

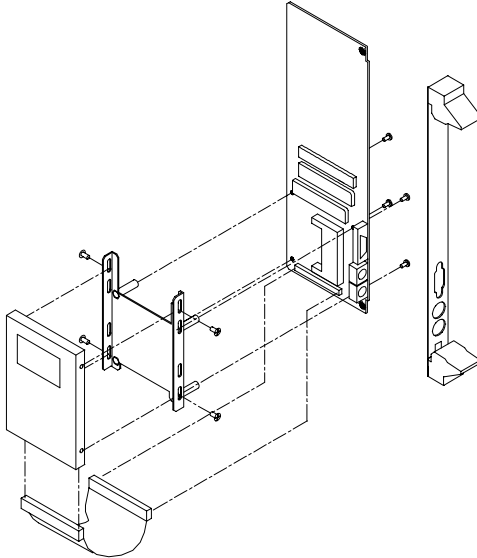

Figure 4-1: Install a 2.5" HDD on MIC-3301

Note:

CN11 and CN24 are all primary IDE channels but in different connector form factors. While connecting IDE drives on both (CN11 and CN24) connectors, please remember to set one as the master and the other one as the slave.

5. J3 Pin Assignment

Table 5-1: MIC-3301 J3 Connector Pin Assignment

Pin	Row A	Row B	Row C	Row D	Row E
19	HDBD3	HDBD6	HDBD2	HDBD10	HDBD14
18	HDBD8	HDBD5	HDBD1	HDBD11	HDBD15
17	HDBD9	HDBD4	HDBD0	HDBD12	HDBD13
16	HDBD7	#ICSOB	#IIORB	#ICS1B	HDRDY8
15	HDBDRQ	#IDACKB	HDBSA2	HDBIRQ	#IIOWB
14	NRTS1	NDSR1	HDBSA1	GND	HDBSA0
13	NR1I	NCTS1	NTX1	NRX1	NRLSD1
12	ID0	ID2	ID4	ID7	NDTR1
11	ID1	ID3	ID8	ID6	ID12
10	ID5	ID9	ID10	ID11	ID13
9	ID15	ID14	#HDRQ	#HCS3	#HIOR
8	HIRQ	#HACK	VCC	HDA2	#HIOW
7	N/A	GND	#HRST1	HRDY	#HCS1
6	N/A	VCC	GND	HDA0	HDA1
5	VCC	N/A	N/A	N/A	N/A
4	KDAT	KCLK	MDAT	MCLK	GND
3	#DSKCHG	#MOA	#STEP	#HEAD	#TRAK0
2	#DSA	#MOB	#RWC	#RDATA	#WP
1	#INDEX	#DSB	#DIR	#WE	#WD

: Low active

Note:

The MIC-3301 does not support DMA/66 HDD.

Part No. 2006330110
Printed in Taiwan

Automation with PCs
ADVANTECH®

2nd Edition
March 2000