

MIC-3032/8

6U 8-slot enclosure with CT bus and
rear I/O for ***CompactPCI™***

Copyright Notice

This document is copyrighted, 2000. All rights are reserved. The original manufacturer reserves the right to make improvements to the products described in this manual at any time without notice.

No part of this manual may be reproduced, copied, translated or transmitted in any form or by any means without the prior written permission of the original manufacturer. Information provided in this manual is intended to be accurate and reliable. However, the original manufacturer assumes no responsibility for its use, nor for any infringements upon the rights of third parties which may result from its use.

Acknowledgements

PICMG™, CompactPCI™ and the PICMG™, CompactPCI™ logos are trademarks of the PCI Industrial Computers Manufacturers Group

All other product names or trademarks are properties of their respective owners.

CE Notification

The MIC-3032/8, developed by Advantech Co., Ltd., has passed the CE test for environment specifications when shielded cables are used for external wiring. We recommend the use of shielded cables.

Part No. 2008303200
Printed in Taiwan

1st Edition
January 2000

Preface and Table of Contents

Product warranty

Advantech warrants to you, the original purchaser, that each of its products will be free from defects in materials and workmanship for one year from the date of purchase.

This warranty does not apply to any products which have been repaired or altered by persons other than repair personnel authorized by Advantech, or which have been subject to misuse, abuse, accident or improper installation. Advantech assumes no liability under the terms of this warranty as a consequence of such events.

Because of Advantech's high quality-control standards and rigorous testing, most of our customers never need to use our repair service. If an Advantech product is defective, it will be repaired or replaced at no charge during the warranty period. For out-of-warranty repairs, you will be billed according to the cost of replacement materials, service time and freight. Please consult your dealer for more details.

If you think you have a defective product, follow these steps:

1. Collect all the information about the problem encountered. For example, CPU speed, Advantech products used, other hardware and software used, etc. Note anything abnormal and list any on-screen messages you get when the problem occurs.
2. Call your dealer and describe the problem. Please have your manual, product, and any helpful information readily available.
3. If your product is diagnosed as defective, obtain an RMA (return merchandise authorization) number from your dealer. This allows us to process your return more quickly.
4. Carefully pack the defective product, a fully-completed Repair and Replacement Order Card and a photocopy proof of purchase date (such as your sales receipt) in a shippable container. A product returned without proof of the purchase date is not eligible for warranty service.
5. Write the RMA number visibly on the outside of the package and ship it prepaid to your dealer.

Packing List

Before installation, ensure that the following materials have been received:

- One MIC-3032/8 CompactPCI enclosure with backplane
- One box of accessories
- One warranty certificate
- MIC-3920/MIC-3921 user's manual
- PC Sentry user's manual
- This user's manual

If any of these items are missing or damaged, contact your distributor or sales representative immediately.

Technical Support and Sales Assistance

If you have any technical questions about the MIC-3032/8 or any other Advantech products, please visit our support website at:

- <http://www.advantech.com.tw/support>

For more information about Advantech's products and sales information, please visit:

- <http://www.advantech.com>

Contents

1. General Information	1
1.1 Introduction	2
1.2 Features	3
1.3 Specifications	4
1.3.1 General	4
1.3.2 Hot-swap Fans	4
1.3.3 Power Supply	5
1.4 Dimensions	6
2. Installation	7
2.1 Initial Inspection	8
2.2 The MIC-3032/8 Illustration	9
2.3 Installation Procedures	11
2.3.1 Card Installation and Removal	11
2.3.2 Before Operating the System	13
2.3.3 Installing Peripherals	13
2.3.4 Installing a 5.25" Device	14
2.3.5 Installing a 3.5" Floppy Disk Drive	15
2.3.6 Replacing the Hot-swap Fan and Air Filter	16

Figures

Figure 1-1: MIC-3032/8 dimensions	6
Figure 2-1: Front view of MIC-3032/8	9
Figure 2-2: Rear view of MIC-3032/8	10
Figure 2-3: Installing a card into the chassis	12
Figure 2-4: Attaching the mounting brackets to a 5.25" device	14
Figure 2-5: Attaching the mounting brackets to a 3.5" floppy disk drive	15
Figure 2-6: Recommended device bay configuration	16

CHAPTER

1

General Information

1.1 Introduction

The MIC-3032/8 is an 8-slot CompactPCI enclosure for rack or panel mounting. This 9U high enclosure provides eight 6U card slots, and has a drive bay which can accommodate devices and peripherals such as floppy disk drives and hard disk drives. The MIC-3032/8 has three cooling fans to provide forced cooling air in the system. These three fans are individually hot-swappable, and users can directly replace any of the fans without interrupting the system's operation. The MIC-3032/8 provides versatile power supply options and are available in three versions:

- MIC-3032/8-9A: CompactPCI 8-slot enclosure with ATX 400 W AC power supply
- MIC-3032/8-9D: CompactPCI 8-slot enclosure with ATX 400 W DC power supply
- MIC-3032/8-9R: CompactPCI 8-slot enclosure with 300 W redundant power supply

The MIC-3032/8 is integrated with a backplane and an alarm module. Please refer to the backplane and alarm module manuals for more detailed information.

1.2 Features

- Eight 6U card slots
- Supports front and rear I/O
- Supports H.110 CT bus
- Drive bay accommodates up to 4 devices, secured by a lockable door
- Versatile power supply options
- Hot-swap compliant backplane
- Hot-swap fans
- Integrated intelligent fault detection and alarm module

1.3 Specifications

1.3.1 General

- **Construction:** Aluminum frame and galvanized sheet steel
- **Drive bay:** Accommodates up to three 5.25"/3.5" drives and one 3.5" floppy disk drive, front removable
- 12-slot space (48 TE), incl. 7 CompactPCI slots and one system slot
- "Hot swappable" platform complies with PICMG 2.1 R 1.0 Hot Swap Specification
- **Dimensions** (W x H x D, mounting flanges not included):
9U: 440 x 400 x 342 mm (17.3" x 16" x 13.5")
- **Weight:** 16 kg
- **Operating temperature:** 0 ~ 50° C (32 ~ 122° F)
- **Storage temperature:** -20° C ~ 60° C (-4 ~ 158° F)
- **Relative humidity:** 10 ~ 95% @ 40° C, non-condensing
- **Operating altitude:** 0 ~ 3,048 meters (0 ~ 10,000 feet)
- **Storage/transit altitude:** 0 ~ 12,190 meters (40,000 feet)
- **Shock:** 10 G (operating); 30 G (storage/transit)
- **Random vibration:** 1.0 Grms (operating)

1.3.2 Hot-swap Fans

- **Air flow:** Three 86-CFM fans, providing 258 CFM in total
- **Power consumption:** 0.45 A @ 12 V per fan, 1.3 A total
- **Rated fan speed:** 2170 rpm
- **Life expectancy:** 50,000 hours @ 25° C

1.3.3 Power Supply

MIC-3032/8-9A (ATX AC power supply)

- **Input:** 90 ~ 135 or 180 ~ 265 V_{AC} @ 47 ~ 63 Hz, switchable
- **Output:** +3.3 V @ 20 A, +5 V @ 42 A, +12 V @ 14 A, -12 V @ 1.0 A
- **Minimum load:** +3.3 V @ 0.3 A, +5V @ 2.5 A
- **Max output:** 400 W total, 160 W for 5 V and 3.3 V
- **MTBF:** 100,000 hours @ 70% load
- **Safety:** UL/CUL/CE

MIC-3032/8-9D (ATX DC power supply)

- **Input:** -38 ~ -72 V_{DC}
- **Output:** +3.3 V @ 20 A, +5 V @ 30 A, +12 V @ 14 A, -12 V @ 1.0 A
- **Minimum load:** +3.3 V @ 0.1 A, +5 V @ 2 A, +12 V @ 1 A
- **Max output:** 250 W total, 170 W for 5 V and 3.3 V
- **MTBF:** 50,000 hours @ 70% load
- **Safety:** UL/CUL/CE

MIC-3032/8-9R (redundant power supply)

- **Input:** 90 ~ 264 @ 47 ~ 63 Hz, switchable
- **Output:** +3.3 V @ 22 A, +5 V @ 30 A, +12 V @ 13 A, -12 V @ 1.0 A
- **Minimum load:** +3.3 V @ 0.3 A, +5V @ 2 A, +12 V @ 0.5 A
- **Max output:** 300 W + 300 W redundant, 160 W for 5 V and 3.3 V
- **MTBF:** 100,000 hours @ 70% load
- **Safety:** UL/CUL/CE

1.4 Dimensions

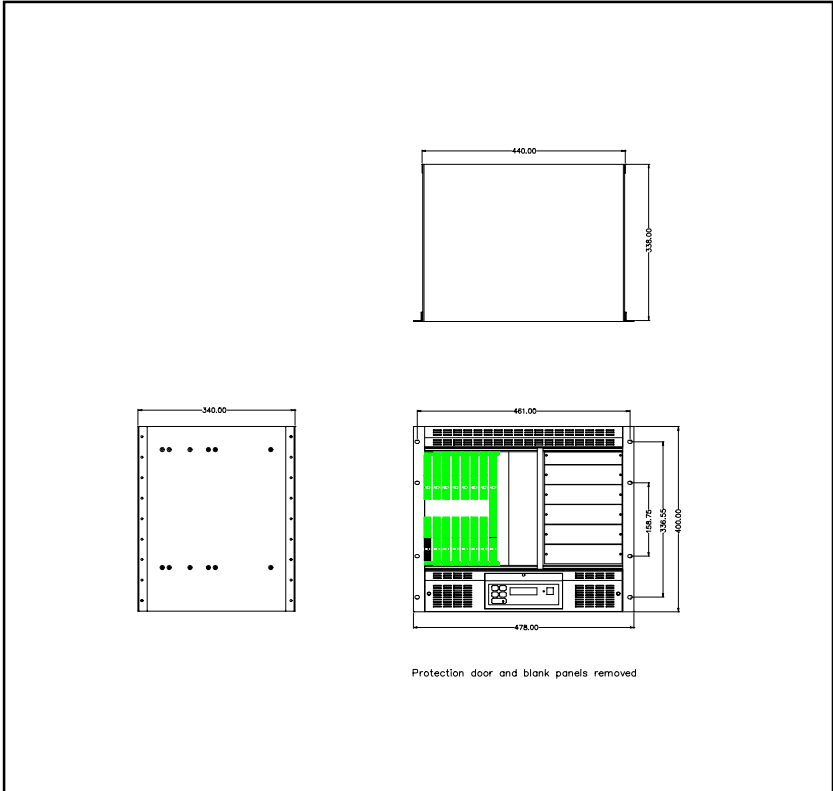

Figure 1-1: MIC-3032/8 dimensions

CHAPTER
2

Installation

2.1 Initial Inspection

We have carefully inspected the MIC-3032/8 mechanically and electrically before shipping. It should be free of marks and scratches and in perfect working order upon receipt.

As you unpack the MIC-3032/8, check it for signs of shipping damage (damaged box, scratches, dents, etc.). If it is damaged or fails to meet specifications, notify our service department or your local representative immediately. Also notify the carrier. Retain the shipping carton and packing material for inspection by the carrier. After inspection, we will make arrangements to repair or replace the unit.

Warning! *We strongly recommend that only qualified, experienced personnel install or remove components. They must exercise extreme caution when doing so.*

2.2 The MIC-3032/8 Illustration

The MIC-3032/8 is designed to be installed and maintained easily. Figure 2-1 and Figure 2-2 illustrate important components on the front and rear side of the enclosure.

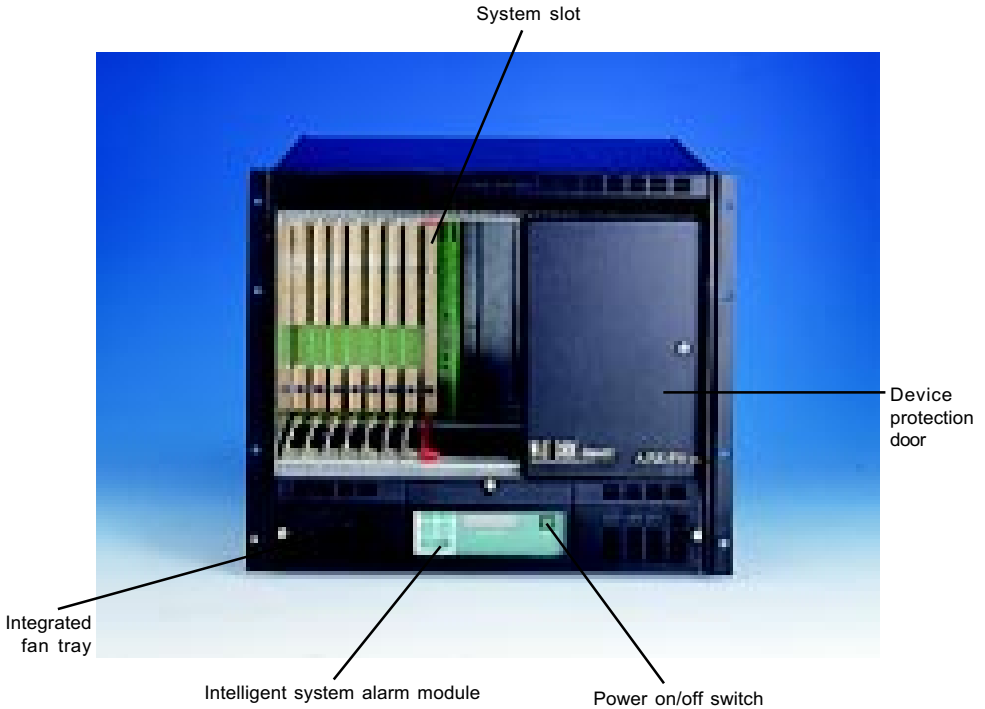

Figure 2-1: Front view of MIC-3032/8

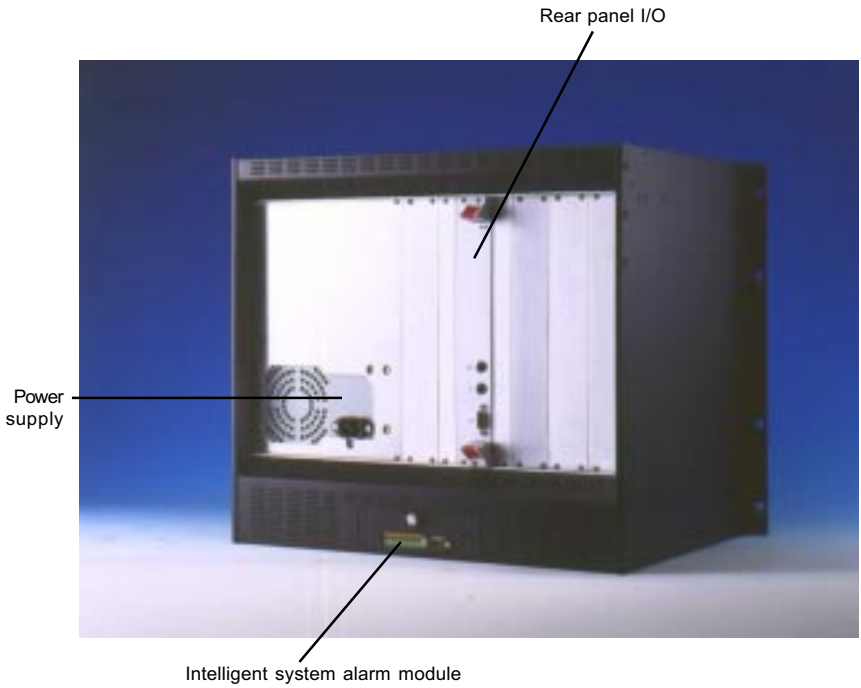

Figure 2-2: Rear view of MIC-3032/8

2.3 Installation Procedures

2.3.1 Card Installation and Removal

The CompactPCI connectors are firm and rigid, and require careful handling while plugging and unplugging. Improper installation of a card can easily damage the backplane of the chassis.

The system card can be installed only in the system slot. The CompactPCI specification allows the system slot to be in any position in the backplane. Do not insert the system card into any other slot, or insert a peripheral card into the system slot. The MIC-3021/8 accepts different backplanes, so the location of the system slot may vary. The system slot is marked by a triangle enclosing the slot number. Please refer to the backplane user's manual.

The insert/eject handles on CompactPCI cards help users to install and remove the cards easily and safely. Follow the procedures below to install a card into a chassis:

To install a card:

1. Hold the card vertically. Be sure that the card is oriented correctly. The components of the card should be pointing to the right-hand side.
2. Be sure that the handles of the card are not latched. Release the handles if they are latched. Handles from different vendors may have different latch designs.

Caution: Keep your fingers away from the latch hinges to prevent your fingers from getting pinched.

3. Insert the card into the chassis by sliding the upper and lower edges of the card into the card guides.
4. Push the card into the slot gently by sliding the card along the card guide until the handles meet the rectangular holes of the cross rails.

Note: *If the card is correctly positioned and has been slid all the way into the chassis, the handles should match the rectangular holes. If not, remove the card from the card guide and repeat step 3 again. Do not try to install a card by forcing it into the chassis.*

5. Pull the upper handle down and lift the lower handle up to push the card into place.
6. Secure the card by locking the handles into place.

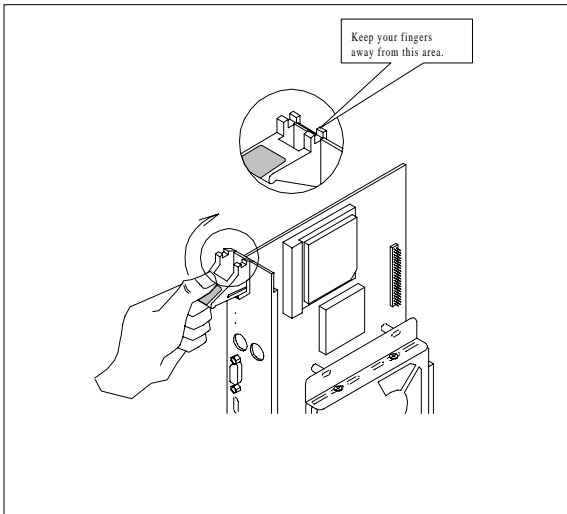

Fig. 2-3: Installing a card into the chassis

To remove a card:

1. Unscrew the screws on the card front panel. Release the locking latches on the handles.
2. Lift the upper handle up and press the lower handle down to release the card from the backplane.
3. Slide the card out.

2.3.2 Before Operating the System

Before operating your system, first check your power supply source. Adjust the switch on the power supply to the correct voltage.

Two mounting flanges are included for users who would like to install the MIC-3032/8 on a 19" rack or on a panel. These flanges can be installed on the front side for rack mounting or on the rear side for panel mounting.

Four rubber stands can be attached to the bottom of the chassis for desktop operation. They are not required for rack mounting.

2.3.3 Installing Peripherals

The device bay of the MIC-3032/8 accepts four devices, including three 5.25"/3.5" devices and one 3.5" floppy disk drive. If the lower two trays in the device bay are not occupied by power supplies, the device bay may accommodate two more devices.

There are two types of mounting brackets shipped with the MIC-3032/8. Three pairs of mounting brackets are designed for mounting 5.25" devices such as hard disk drives or CD-ROM drives. Please refer to Figure 2-4 for an illustration of mounting. However, if users would like to use a 3.5" hard disk drive in the MIC-3032/8, extension brackets (3.5" to 5.25") are required. These extension brackets are commonly available in PC shops, or users can contact an Advantech distributor to order them. For mounting a 3.5" floppy disk drive, a pair of mounting brackets are provided. Users can mount the floppy disk drive on the top tray in the device bay. Please refer to Figure 2-5 for an illustration of mounting. Figure 2-6 shows the recommended device bay configuration.

2.3.4 Installing a 5.25" Device

Follow the procedures below to install a 5.25"/3.5" device:

1. Fasten one pair of mounting brackets to both sides of a 5.25" device (or a 3.5" device with extension brackets). Note that the guide edges of the mounting brackets should be on the lower side.

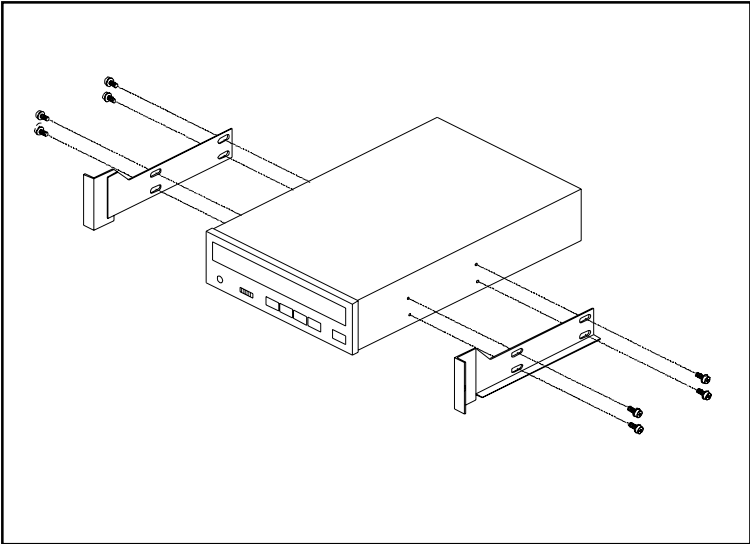

Figure 2-4: Attaching the mounting brackets to a 5.25" device

2. Unfasten and remove the cover plate of the device tray.
3. Insert the device with attached mounting brackets into the device tray.
4. Fasten the mounting brackets to the device bay, and then fasten the cover plate (for internal devices only).
5. Open the back cover of the chassis, and connect the cables to the installed device and to the rear transition board.
6. Close the back cover.

2.3.5 Installing a 3.5" Floppy Disk Drive

A space is reserved for a 3.5" floppy disk drive on the top of the device bay. Follow the procedures below to install a 3.5" floppy disk drive.

1. Fasten one pair of mounting brackets to both sides of a 3.5" floppy disk drive. Note that the guide edges of the mounting brackets should be on the lower side.
2. Unfasten and remove the top cover plate of the device tray.
3. Insert the floppy disk drive with attached mounting brackets into the device tray.
4. Fasten the mounting brackets to the device bay.
5. Open the back cover of the chassis, and connect the cables to the installed device and to the rear transition board.
6. Close the back cover.

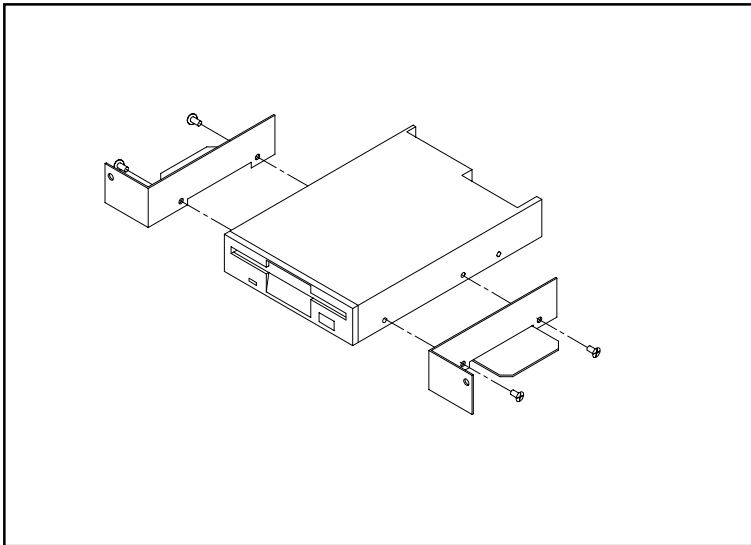

Figure 2-5: Attaching the mounting brackets to a 3.5" floppy disk drive



Figure 2-6: Recommended device bay configuration

2.3.6 Replacing the Hot-swap Fan and Air Filter

The MIC-3032/8 provides three hot-swap fans underneath the card slots. Each fan can be individually replaced. This can be done without turning off the system power or interrupting system operation.

Follow these steps to replace a fan:

1. Unfasten the fan's holder.
2. Slide the fan's holder out.
3. Replace the old fan with a new one.
4. Slide the fan's holder in.
5. Fasten the new fan's holder.

The air filter may become dirty after a period of time. Follow these steps to replace a filter:

1. Remove the filter cover.
2. Replace the dirty filter with a clean one.
3. Reattach the filter cover.

Repeat steps 1 to 3 to replace other filters.

