

FPM-3180

Industrial Flat Panel Monitor with 18.1" LCD in Direct-VGA Port



Features

- 18.1" SXGA TFT LCD with resolution up to 1280 X 1024
- Stainless steel chassis with NEMA4/IP65-compliant aluminum front panel
- Multi-scan function supports SXGA, XGA, SVGA, VGA, VGA-Text, PC-9801, MAC
- Ultra-wide viewing angle with anti-glare feature
- High luminance up to 200 cd/m2
- Auto-recognition of input signal

Introduction

FPM-3180 is an 18-inch color TFT LCD flat panel monitor specially designed for industrial applications. With a viewing size as large as 18.1", it presents an ample display area as well as vivid and sharp images for your HMI. FPM-3180 features Direct-VGA signal transmission, which allows a regular VGA control card to be used on your system. Users can thus upgrade his display without making changes to the existing system. Its On Screen Display function also allows users to adjust the images on screen with ease. The whole chassis is of stainless steel, and the front panel is made of aluminum with NEMA4/IP65 compliance.

Specification

- **Front panel:** Aluminum, NEMA4/IP65 compliant
- **Mounting:** Panel or wallmount
- **Dimensions (W x H x D):** 500 x 406 x 90 mm (19.7" x 16" x 3.5")
- **Gross Weight:** 13.5 Kg (29.8 lbs)
- **I/O port:** keyboard connector, DC power input, power switch, and RS-232 port (Touchscreen version only)
- **Control:** OSD (OnScreen Display) Control Pads on the front side
- **Power Adaptor:** External Power Adapter AC 110 V, +12 V @ 6 A output

Touchscreen (optional)

- **Type:** 8 wire, analog resistive
- **Resolution:** continuous
- **Light transmission:** 75%
- **Operating pressure:** 30 ~ 45 gram for stylus pen, contact bounce < 10 ms (meets ASTM-D-3363-92A Standard, Taber abrasion test)
- **Controller:** RS-232 interface
- **Power Consumption:** +5 V @ 200 mA

- **OS support:** MS-DOS, Windows 3.1, Windows 95, Windows 98, Windows NT, IBM OS2
- **Lifespan:** 100 million touches

LCD Specification	
Display type	SXGA TFT LCD
Display size	18.1"
Max colors	full color (16 million)
Max resolution	1280 X 1024
Dot pitch	0.28 X 0.28 mm
View Angle	160°
Luminance	200 cd/m ² 8 CCFL
Storage Temperature	-20 ~ 60° C
Operating Temperature	0 ~ 50° C
Backlight	8 cold cathode fluorescence lamps (replaceable)
Contrast Ratio	150: 1 (typ)



Industrial Flat Panel Monitor with 18.1" LCD in Direct-VGA Port

Dimensions

Unit: mm

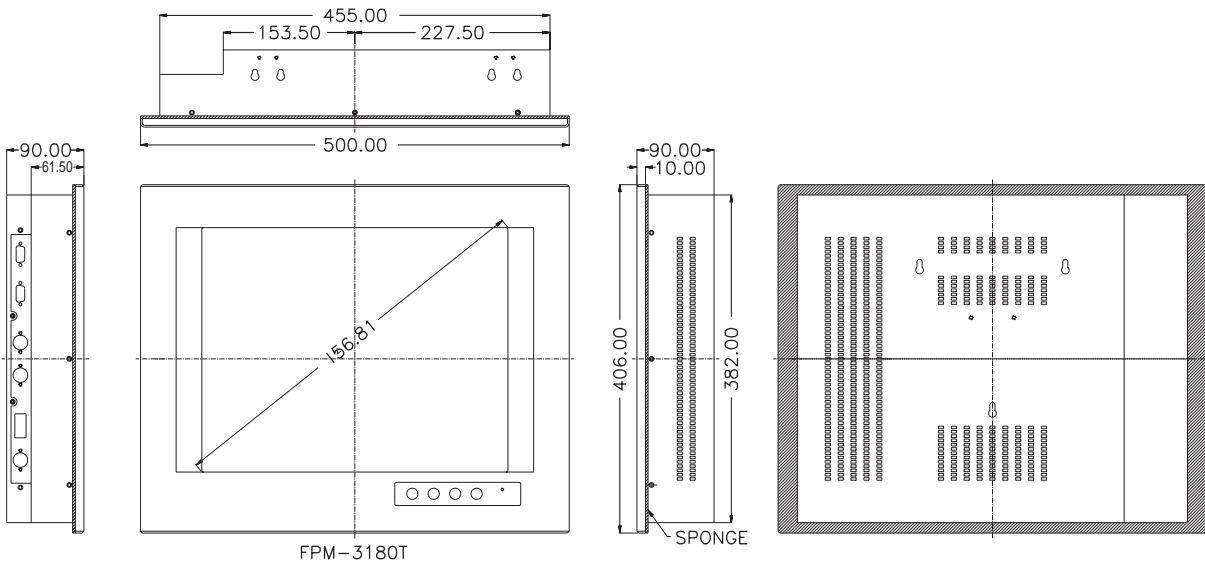

FPM-3180T

Cut out dimension: 461 x 388 mm (18.1" x 15.2")

Installation

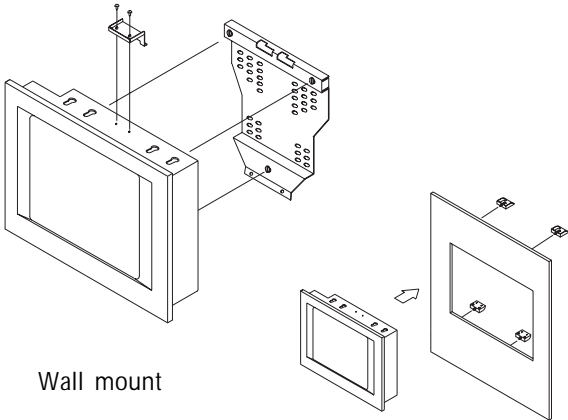

Wall mount

Panel mount

Ordering Information

- FPM-3180TV**
Industrial flat panel monitor with 18.1" TFT LCD display
- FPM-3180TV-T**
FPM-3180TV with touchscreen
- FPM-3180TV-N**
FPM-3180TV with NFI touchscreen