

FPM-3155 Series

Industrial Flat Panel
Monitor with 15" LCD
VGA/Video

Users Manual

Copyright

This document is copyrighted by Advantech Co., Ltd. All rights are reserved. Advantech Co., Ltd. reserves the right to make improvements to the products described in this manual at any time. Specifications are thus subject to change without notice.

No part of this manual may be reproduced, copied, translated, or transmitted in any form or by any means without the prior written permission of Advantech Co., Ltd. Information provided in this manual is intended to be accurate and reliable. However, Advantech Co., Ltd., assumes no responsibility for its use, nor for any infringements upon the rights of third parties which may result from its use.

All brand and product names mentioned herein are trademarks or registered trademarks of their respective holders.

FCC Class B

This equipment has been tested and found to comply with the limits for a Class B digital device, pursuant to Part 15 of the FCC Rules. These limits are designed to provide reasonable protection against harmful interference when the equipment is operated in a residential environment. This equipment generates, uses and can radiate radio frequency energy. If not installed and used in accordance with this user's manual, it may cause harmful interference to radio communications. Note that even when this equipment is installed and used in accordance with this user's manual, there is still no guarantee that interference will not occur. If this equipment is believed to be causing harmful interference to radio or television reception, this can be determined by turning the equipment on and off. If the interference is occurring, the user is encouraged to try to correct the interference by one or more of the following measures:

- Reorient or relocate the receiving antenna
- Increase the separation between the equipment and the receiver
- Connect the equipment to a power outlet on a circuit different from that to which the receiver is connected
- Consult the dealer or an experienced radio/TV technician for help

警告使用者

這是甲類的資訊產品，在居住的環境中使用時，可能會造成射頻干擾，在這種情況下，使用者會被要求採取某些適當的對策。

Packing List

Before installing your equipment, make sure that the following materials have been received:

- FPM-3155 Series flat panel monitor
- Accessory pack, including:
 - AC/DC adapter
 - Power Chord
 - Video signal cable
 - Component bag
 - Screw bag
 - HMI Products, Drivers, Utilities CD
 - FPM-3155 Series User's Manual
 - RS-232 cable (FPM-3155TV-T only)
 - TSCB-9516 drivers installation guide (FPM-3155TV-T only)

If any of these items is missing or damaged, contact your distributor or sales representative immediately.

Additional Information and Assistance

1. Visit the Advantech web site at **www.advantech.com** where you can find the latest information about the product.
2. Contact your distributor, sales representative, or Advantech's customer service center for technical support if you need additional assistance. Please have the following information ready before you call:

- Product name and serial number
- Description of your peripheral attachments
- Description of your software (operating system, version, application software, etc.)
- A complete description of the problem
- The exact wording of any error messages

Safety Instructions

1. Read these safety instructions carefully.
2. Keep this User's Manual for later reference.
3. Disconnect this equipment from any AC outlet before cleaning. Use a damp cloth. Do not use liquid or spray detergents for cleaning.
4. For plug-in equipment, the power outlet socket must be located near the equipment and must be easily accessible.
5. Keep this equipment away from humidity.
6. Put this equipment on a reliable surface during installation. Dropping it or letting it fall may cause damage.
7. The openings on the enclosure are for air convection. Protect the equipment from overheating. **DO NOT COVER THE OPENINGS.**
8. Make sure the voltage of the power source is correct before connecting the equipment to the power outlet.
9. Position the power cord so that people cannot step on it. Do not place anything over the power cord.
10. All cautions and warnings on the equipment should be noted.
11. If the equipment is not used for a long time, disconnect it from the power source to avoid damage by transient overvoltage.
12. Never pour any liquid into an opening. This may cause fire or electrical shock.
13. Never open the equipment. For safety reasons, the equipment should be opened only by qualified service personnel.
14. If one of the following situations arises, get the equipment checked by service personnel:
 - a. The power cord or plug is damaged.
 - b. Liquid has penetrated into the equipment.
 - c. The equipment has been exposed to moisture.
 - d. The equipment does not work well, or you cannot get it to work according to the user's manual.
 - e. The equipment has been dropped and damaged.
 - f. The equipment has obvious signs of breakage.
15. **DO NOT LEAVE THIS EQUIPMENT IN AN UNCONTROLLED ENVIRONMENT WHERE THE STORAGE TEMPERATURE IS BELOW -20° C (-4° F) OR ABOVE 60° C (140° F). THIS MAY DAMAGE THE EQUIPMENT.**

The sound pressure level at the operator's position according to IEC 704-1:1982 is no more than 70dB(A).

DISCLAIMER: This set of instructions is given according to IEC 704-1. Advantech disclaims all responsibility for the accuracy of any statements contained herein.

Wichtige Sicherheitshinweise

1. Bitte lesen sie Sich diese Hinweise sorgfältig durch.
2. Heben Sie diese Anleitung für den späteren Gebrauch auf.
3. Vor jedem Reinigen ist das Gerät vom Stromnetz zu trennen. Verwenden Sie Keine Flüssig-oder Aerosolreiniger. Am besten dient ein angefeuchtetes Tuch zur Reinigung.
4. Die Netzanschlussteckdose soll nahe dem Gerät angebracht und leicht zugänglich sein.
5. Das Gerät ist vor Feuchtigkeit zu schützen.
6. Bei der Aufstellung des Gerätes ist auf sicheren Stand zu achten. Ein Kippen oder Fallen könnte Verletzungen hervorrufen.
7. Die Belüftungsöffnungen dienen zur Luftzirkulation die das Gerät vor überhitzung schützt. Sorgen Sie dafür, daß diese Öffnungen nicht abgedeckt werden.
8. Beachten Sie beim Anschluß an das Stromnetz die Anschlußwerte.
9. Verlegen Sie die Netzanschlusbleitung so, daß niemand darüber fallen kann. Es sollte auch nichts auf der Leitung abgestellt werden.
10. Alle Hinweise und Warnungen die sich am Geräten befinden sind zu beachten.
11. Wird das Gerät über einen längeren Zeitraum nicht benutzt, sollten Sie es vom Stromnetz trennen. Somit wird im Falle einer Überspannung eine Beschädigung vermieden.
12. Durch die Lüftungsöffnungen dürfen niemals Gegenstände oder Flüssigkeiten in das Gerät gelangen. Dies könnte einen Brand bzw. elektrischen Schlag auslösen.
13. Öffnen Sie niemals das Gerät. Das Gerät darf aus Gründen der elektrischen Sicherheit nur von autorisiertem Servicepersonal geöffnet werden.
14. Wenn folgende Situationen auftreten ist das Gerät vom Stromnetz zu trennen und von einer qualifizierten Servicestelle zu überprüfen:
 - a - Netzkabel oder Netzstecker sind beschädigt.
 - b - Flüssigkeit ist in das Gerät eingedrungen.
 - c - Das Gerät war Feuchtigkeit ausgesetzt.
 - d - Wenn das Gerät nicht der Bedienungsanleitung entsprechend funktioniert oder Sie mit Hilfe dieser Anleitung keine Verbesserung erzielen.
 - e - Das Gerät ist gefallen und/oder das Gehäuse ist beschädigt.
 - f - Wenn das Gerät deutliche Anzeichen eines Defektes aufweist.

Der arbeitsplatzbezogene Schalldruckpegel nach DIN 45 635 Teil 1000 beträgt 70dB(A) oder weiger.

DISCLAIMER: This set of instructions is given according to IEC704-1. Advantech disclaims all responsibility for the accuracy of any statements contained herein.

Contents

Packing List	iv
Additional Information and Assistance	iv
Safety Instructions	v
Wichtige Sicherheitshinweise.....	vi
Chapter 1 Introduction	2
1.1 Introduction	2
1.2 Specifications	2
1.3 LCD Specification	3
1.4 Connectors	4
1.5 Dimensions	5
.....	5
Figure 1.1: FPM-3155 Dimensions.....	5
Chapter 2 System Setup	8
2.1 Mounting the Monitor	8
2.1.1 Wall Mounting.....	8
Figure 2-1: Wall Mounting	8
2.1.2 Panel Mounting.....	9
Figure 2-2: Panel Mounting (cut out dimensions: 396 x 296 mm) ...	9
2.1.3 Rack Mounting	10
Figure 2-3: Rack Mounting.....	10
2.2 Desktop, Swingarm mounting	11
2.2.1 Desktop Stand.....	11
Figure 2.4: Desktop Stand for the FPM-3155 series.....	11
2.2.2 Swing-ARM.....	12
Figure 2.5: Swing-ARM for the FPM-3155 series.....	12
Appendix A Touchscreen Driver Installation	14
A.1 Introduction	14
A.2 Touchscreen specifications	14
A.3 Installation of Touchscreen Driver	15
Appendix B Supported Input Timing Modes.....	18
B.1 Supported Input Timing Modes	18
Table B-1: Supported Input formats	18
Appendix C OSD Operation	20
C.1 OSD Operation Keypad	20
Table C-1: Keypad functions	20
C.2 OSD Functions.....	21
Figure C-1 OSD Menu	21
C.3 Feature Descriptions	21

Introduction

This chapter includes:

- Introduction
- Specifications
- LCD Specification
- Connectors
- Dimensions

Chapter 1 Introduction

1.1 Introduction

Advantech's FPM-3155 Series is a 15" color TFT LCD flat panel monitor built specifically for industrial applications. With the optional touchscreen, the FPM-3155 Series is an excellent and user-friendly system control interface.

In addition to its usual application as an LCD panel monitor, the FPM-3155 comes standard with Direct-VGA and Video interface, which not only could directly connect to popular PC VGA cards, but also could connect to devices with video output, like cameras. With the FPM-3155, Advantech is taking a more aggressive initiative to penetrate the industrial HMI market. Its OSD (On Screen Display) function allows you to adjust the display factors and turn the backlight on and off for the front view, functions which become critical as more and more industrial HMI users become aware of the benefits of flat panel monitors. The whole chassis is of stainless steel, and the front panel is of aluminum with NEMA4/IP65 compliance.

The FPM-3155 provides a touch screen version (FPM-3155TV-T) for option. With an 8-wire resistive type touchscreen, the monitor can be immediately transformed into a remote control system.

1.2 Specifications

General

- **Control:** OSD (On Screen Display) control pad on front side
- **Mounting:** Panelmount, wallmount. Supports VESA arm mounting and optional rackmount kit (Part Number: FPM-3150Rack-MT)
- **I/O port:** VGA connector, Video connector, DC power input, power switch, and RS-232 port (Touchscreen version only)
- **Power Adaptor:** External Power Adapter AC 110 V, +12 V @ 5 A output
- **Operating temperature:** 0 ° ~ 50 ° C
- **Storage temp:** -20 ° ~ 60 ° C
- **Storage humidity:** 5% ~ 95% non-condensing
- **Vibration (operating):** 5 ~ 17 Hz, double-amplitude displacement
17 ~ 500 Hz, 1.0 G peak to peak

- **Dimensions:** (W x H x D):428 x 310 x 84 mm (16.9" x 12.2" x 3.3")
- **Weight:**7 Kgs (15.4 lbs)
- CE, FCC, BSMI, CCIB compliant

Touchscreen (Optional)

- **Type:** 8 wire, analog resistive
- **Resolution:** continuous
- **Light transmission:** 72%
- **Operating Pressure:** 30 ~ 45 gram for stylus pen, contact bounce < 10 ms
- **Controller:** RS-232 interface
- **Power Consumption:** +5 V @ 200 mA
- **OS support:** MS-DOS, Windows 3.1/95/98/NT/2000
- **Life span:** 100 million touches

1.3 LCD Specification

- **Display type:** XGA TFT LCD
- **Display size:** 15"
- **Max. colors:** Full Color (16 million)
- **Max. resolution:** 1024 x 768
- **Dot pitch:** 0.297 x 0.297 mm
- **View angle:** 120° (H), 100° (V)
- **Luminance:** 200 cd/m², 2 CCFL
- **Storage temperature:** -20° ~ 60° C
- **Operating temperature:** 0° ~ 50° C
- **Backlight Lifetime:** 25,000 hrs.
- **Contrast Ratio:** 350:1

1.4 Connectors

The following connectors are situated on the left hand side of the FPM-3155 Series:

VGA Port (DB-15)

This DB-15 connector can be connected to the system via the external 15-pin DB-15 connector located on the left side of the system unit.

Video Port (Mini-DIN 4 pin)

Supports NTSC and PAL.

S-Video port

Touchscreen Connector (DB-9) (optional)

This connector will be present only if a touchscreen is installed. It must be connected to the RS-232 port of the PC. The touchscreen cable is included with all orders which include the touchscreen option.

DC 12 V Power in

This connector will be connected to the DC 12V Switching Power Supply.

Extended Cable Transmission (optional)

A 5/20/30/50-meter VGA cable is provided for special applications. Another longer cable is also available. For more detailed information, please contact our dealers.

1.5 Dimensions

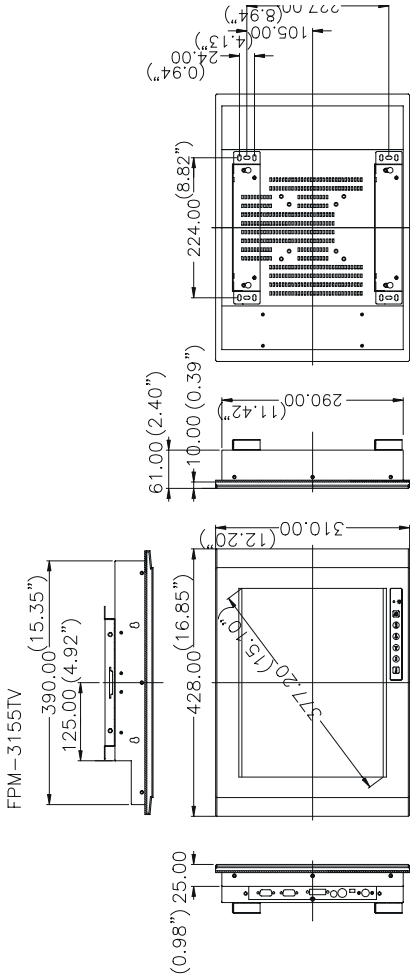

Cutout Dimensions: 396 x 296 mm (15.6" x 11.6")

Figure 1.1: FPM-3155 Dimensions

CHAPTER 2

System Setup

This chapter includes:

- Mounting the Monitor
 - Wall/Panel/Rack Mounting
 - Desktop Stand/Swing-ARM Mounting

Chapter 2 System Setup

2.1 Mounting the Monitor

The FPM-3155 Series can be placed as you require. The versatility of the FPM-3155 mounts enable it to be mounted on your desk or anywhere else.

2.1.1 Wall Mounting

With wall brackets, the FPM-3155 can be mounted directly to a wall.

If you need to install the FPM-3155 in different ways, release the mounting brackets by detaching the four screws on the rear side.

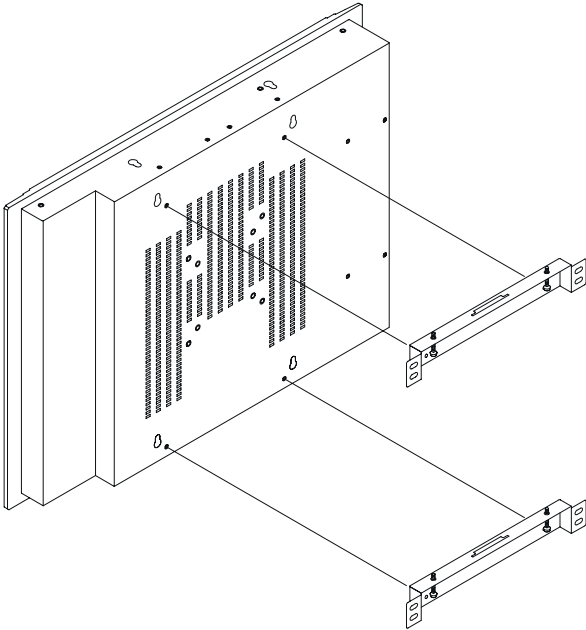

Figure 2-1: Wall Mounting

2.1.2 Panel Mounting

If you need to install the FPM-3155 series on a panel mount, please release the mounting brackets by detaching four screws on rear side and fix them on up and bottom side by screws.

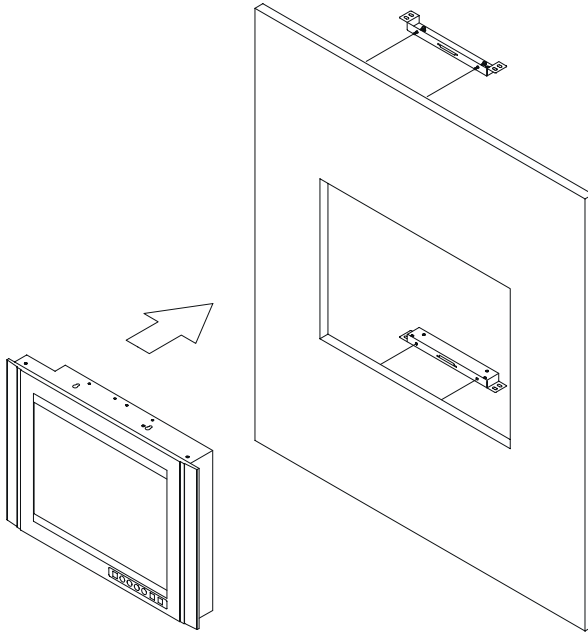

Figure 2-2: Panel Mounting (cut out dimensions: 396 x 296 mm)

2.1.3 Rack Mounting

To install the FPM-3155 on a 19" rack, you need rack mount kit FPM-3150Rack-MT (4 bracket pieces). Assemble the rack mount brackets with 12 screws, then affix the monitor on the rack.

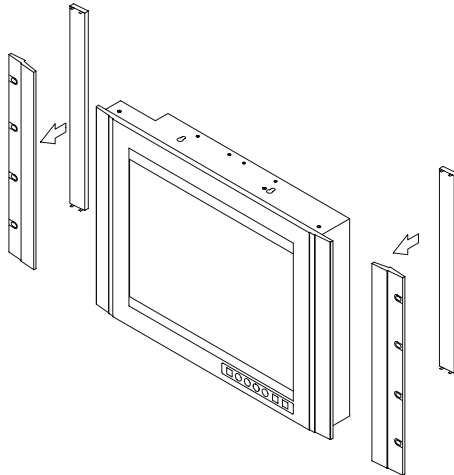

Figure 2-3: Rack Mounting

2.2 Desktop, Swingarm mounting

The FPM-3155 Series can be mounted in other ways. You can place the desktop stand for desktop use or attach it on a swing-arm bracket.

2.2.1 Desktop Stand

The desktop stand bracket is attached to the rear of the FPM-3155. Simply detach the small bracket at the top of the monitor by unscrewing the two screws. The lower bracket now becomes the desktop stand bracket.

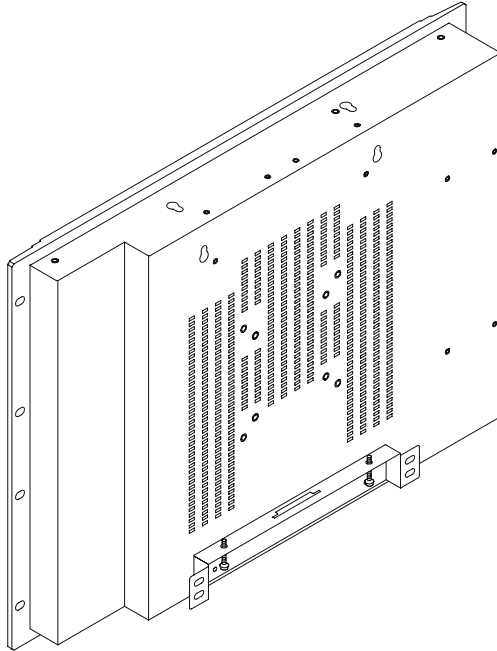

Figure 2.4: Desktop Stand for the FPM-3155 series

2.2.2 Swing-ARM

Detach the mounting brackets on the rear side, then attach the FPM-3155 series onto the Swing-ARM mount (75mm or 100mm square bracket).

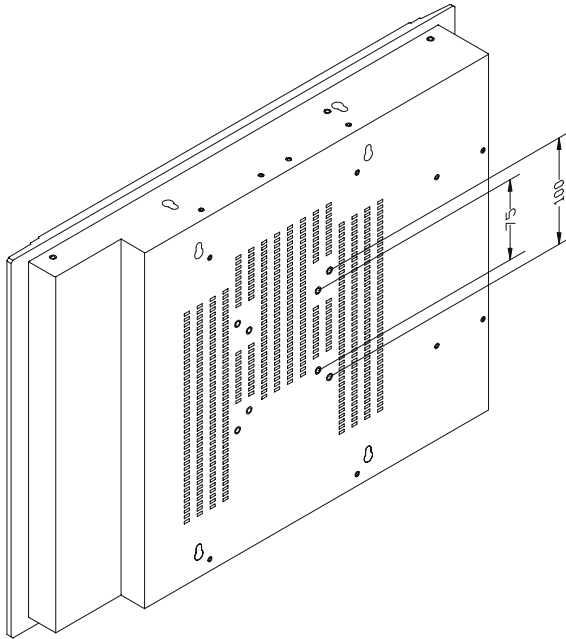

Figure 2.5: Swing-ARM for the FPM-3155 series

Touchscreen Driver Installation

- Introduction
- Specification
- Installation

Appendix A Touchscreen Driver Installation

A.1 Introduction

The FPM-3155 Series' optional touchscreen uses an advanced 8-wire resistive technology. It provides more accurate sensing capacity than other technologies. The touchscreen is specially designed for tough industrial environments, and has been approved to FCC Class A and Class B standards.

A.2 Touchscreen specifications

Electrical

- **Contact bounce:** < 10 ms
- **Operating voltage:** 5 V (typical)
- **Contact current:** 20 mA (max.)
- **Circuit resistance:** Open: > 30 mohms
Closed: < 2000 mohms
- **Sheet resistance variation:** Within one screen: $\pm 5\%$
From screen to screen: $\pm 20\%$

Durability

Test conditions: 4H hardness, 0.04" stylus pen, 350 gram load

- **Point activation:**
Single point, position of stylus controlled to $\pm 0.0005"$
Result: > 1 million activations
- **Linear activation:**
2" diagonal line, position of stylus controlled to $\pm 0.0005"$
Result: > 250,000 cycles
- **Chemical resistance:** Hard coating is highly resistant to most solvents and chemicals

Optical

- **Visible light transmission:** 72% (typical)
- **Reflection:** > 25% @ 550 nm

Sensor board

- Chemical strengthened glass meets “4H” hardness standard (Test condition: ASTM D3363-92A)

Ball drop test

- Touchscreen can withstand a 225g steel ball dropped from a height of 660 mm, without breaking

Environmental

- **Operating pressure:** 30 ~ 45 grams for finger; 10 grams for stylus pen
- **Operating temperature:** 0 ~ 50° C (humidity 20 ~ 90% RH)
- **Storage temperature:** -25 ~ 70° C (humidity 20 ~ 95% RH)

A.3 Installation of Touchscreen Driver

The touchscreen for the FPM-3155 Series provides drivers for use with MS-DOS, Windows 3.1, 95, 98, NT, and 2000. For the detailed touchscreen driver installation procedure, please refer to the “TSCB-9516 Driver Installation Guide” in the accessory box.

Appendix

B

Supported Input Timing Modes

Appendix B Supported Input Timing Modes

B.1 Supported Input Timing Modes

The nineteen kinds of timings below are already programmed in this module. The input synchronous signals are automatically recognized.

Resolution	Vertical Frequencies					
	56Hz	60Hz	70Hz	72Hz	75Hz	85Hz
640x480		Yes		Yes	Yes	Yes
800x600	Yes	Yes	Yes	Yes	Yes	Yes
1024x768		Yes	Yes		Yes	Yes
1280x1024		Yes	Yes		Yes	Yes
1600x1200						

Table B-1: Supported Input formats

- Note 1:** Even if the preset timing is entered, a little adjustment of the functions such as Horizontal period, CLK-delay and display position, are required. The adjusted values are memorized in every preset number.
- Note 2:** This module recognizes the synchronous signals with near preset timing of the frequency of the HS and Vsync, even in the case that the signals other than the preset timing that were entered.
- Note 3:** Because adjustments may not fit, such as differing magnifying ratios or, in the case that you use it except for the display timing that was preset.

Appendix

C

OSD Operation Keypad

Appendix C OSD Operation

C.1 OSD Operation Keypad

The OSD keypad, including six keys and a two color indicator, is designed as the OSD operation interface.

The six keypad functions are in Table C-1.

Auto	Press this button to execute auto adjustment process
Sel	Press to show the OSD screen or select an item to change its setting
◀ ▶	To move between items or increase or decrease setting
Exit	This key has two functions: 1.) To exit from the current setting in OSD function 2.) To switch the input source between RGB, Video and S-Video
On/OFF	Turns display backlight ON and OFF

Table C-1: Keypad functions

Note: The green light means that the COMMON board detects the input signal and ends output signal to LCD panel.

C-2 OSD Function

Each selected value is stored into LCD memory after SEL signal input or time out. The stored values are not affected if the power is turned off. But the selected value is not available in case a selected mode is changed before time out or power is turned off before time out.

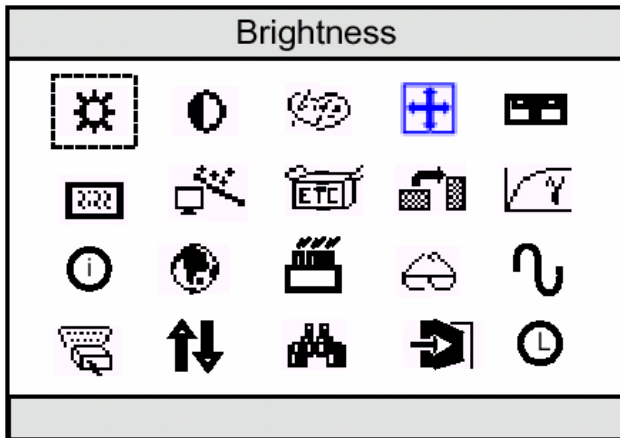

Figure C-1: OSD Menu

C.3 Feature Descriptions

Brightness- Press the ◀ and ▶ keys to adjust the brightness. Note: this menu adjusts the back-light intensity using the PWM feature.

Contrast- Press the ◀ and ▶ keys to adjust the contrast. Note: this menu adjusts the contrast using the digital contrast control.

Language- Press the ▶ key to select the language of your choice.

Advanced Features- Press the ▶ key to access advanced features of this monitor.

Exit- Press the ▶ key to exit the menus.

Digital Color Controls- Press the ► key to adjust the digital controls such as black level, red/green/blue gain, hue & saturation, flesh-tone compensation and color.

Analog Settings- Press the ► key to adjust controls such as brightness, contrast, Horizontal and vertical position, phase, clocks per line and auto configuration.

OSD Settings- Press the ► key to adjust OSD controls such as time out, H and V- position and OSD size.

Misc- Press the ► key to adjust miscellaneous settings such as sharpness control, moire cancellation, scaling enhancement, factory reset, force input and overlap modes.

Digital Brightness- Press the ◀ and ► keys to digitally adjust the brightness.

Black Level- Press the ◀ and ► keys to adjust digital black level control.

Red Level- Press the ◀ and ► keys to adjust the digital red level.

Green Level- Press the ◀ and ► keys to adjust the digital green level.

Hue- Press the ◀ and ► keys to digitally adjust the hue.

Saturation- Press the ◀ and ► keys to adjust saturation.

Real Color™ Flesh Tone Adjustment- Press the ◀ and ► keys to digitally compensate for flesh tones.

Color Temperature- Press the ◀ and ► keys to select a color temperature that makes screen white look like paper white.

H-Position- Press the ◀ and ► keys to move the screen left or right along the capture window.

V-Position- Press the ◀ and ► keys to move the screen up or down by moving the analog capture window.

Phase- Press the ◀ and ► keys to adjust the sampling phase of the analog to digital converter.

Clocks- Press the ◀ and ▶ keys to adjust the number of clocks per line in the analog to digital converter.

Auto Config- Press the ▶ key to automatically configure the above settings.

OSD-Timeout- Press the ◀ and ▶ keys to decrease or increase the amount of time that elapses before the menu disappears.

OSDH-Position- Press the ◀ and ▶ keys to adjust the horizontal position of the menu.

OSDV-Position- Press the ◀ and ▶ keys to adjust the Vertical position of the menu.

OSDSize- Press the ◀ and ▶ keys to decrease or increase the size of the menu.

Low Zoom Factor Sharpening- Press the ◀ and ▶ keys to use adaptive Contrast Enhancement to adjust the sharpness when scaling textual images.

High Zoom Factor Sharpening- Press the ▶ key to select a different video filter that sharpens graphical images when scaling from very low resolutions or press Press the ◀ key to select a smoother scaling algorithm.

Moire Cancellation- Press the ◀ and ▶ keys to remove patterns due to non-linearities when scaling from a low resolution to SXGA resolution (or XGA resolution, depending on panel).

Select Source- Press the ◀ and ▶ keys to select the input source you would like to view. Use 'AUTO' to let the monitor do it automatically. (AUTO selects in the following priority: Digital RGB, Analog RGB, S-Video, Composite Video initially. When there is more than one input active, the source remains the previously active source).

Factory Reset- Press the ▶ key to reset all user settings and then confirm user settings. The stored in NVRAM will be lost.

Analog Brightness- Press the ◀ and ▶ keys to adjust analog RGB offset.

Analog Contrast- Press the ◀ and ▶ keys to adjust analog RGB gain.

Red Gain- Press the ◀ and ▶ keys to adjust the red gain.

Green Gain- Press the ◀ and ▶ keys to adjust the green gain.

Blue Gain- Press the ◀ and ▶ keys to adjust the blue gain.

Firmware version- This monitor uses software version X.XX

Overlapped Modes- Press the ◀ and ▶ keys to tell the monitor to use DOS mode timings (720 pxl/line) or EGA/CGA timing (640 pxl/line) when these modes are otherwise indistinguishable.

Switcher OFF/ON- Press the ▶ key to deactivate format detection or press the ◀ key to activate format detection.