



**User Manual**

# **AIMB-252 (910GMLE/915GME)**

**Intel® 910GMLE  $\mu$ FC-BGA 479  
(or 915GME  $\mu$ FC-PGA 478)  
Pentium® M / Celeron® M Mini  
ITX Main Board  
Ver.1.00**

*Trusted ePlatform Services*

**ADVANTECH**

---

# Safety Information

## Electrical safety

- To prevent electrical shock hazard, disconnect the power cable from the electrical outlet before relocating the system.
- When adding or removing devices to or from the system, ensure that the power cables for the devices are unplugged before the signal cables are connected. If possible, disconnect all power cables from the existing system before you add a device.
- Before connecting or removing signal cables from the motherboard, ensure that all power cables are unplugged.
- Seek professional assistance before using an adapter or extension cord. These devices could interrupt the grounding circuit.
- Make sure that your power supply is set to the correct voltage in your area. If you are not sure about the voltage of the electrical outlet you are using, contact your local power company.
- If the power supply is broken, do not try to fix it by yourself. Contact a qualified service technician or your retailer.

## Operation safety

- Before installing the motherboard and adding devices on it, carefully read all the manuals that came with the package.
- Before using the product, make sure all cables are correctly connected and the power cables are not damaged. If you detect any damage, contact your dealer immediately.
- To avoid short circuits, keep paper clips, screws, and staples away from connectors, slots, sockets and circuitry.
- Avoid dust, humidity, and temperature extremes. Do not place the product in any area where it may become wet.
- Place the product on a stable surface.
- If you encounter technical problems with the product, contact a qualified service technician or your retailer.

**Caution!** The symbol of the crossed out wheeled bin indicates that the product (electrical and electronic equipment) should not be placed in municipal waste. Check local regulations for disposal of electronic products.



## Certifications

# FCC

This device complies with the requirements in part 15 of the FCC rules: Operation is subject to the following two conditions:

- This device may not cause harmful interference,
- This device must accept any interference received, including interference that may cause undesired operation.

This equipment has been tested and found to comply with the limits for a Class A digital device, pursuant to Part 15 of the FCC Rules. These limits are designed to provide reasonable protection against harmful interference when the equipment is operated in a commercial environment. This equipment generates, uses, and can radiate radio frequency energy and, if not installed and used in accordance with the instruction manual, may cause harmful interference to radio communications. Operation of this device in a residential area is likely to cause harmful interference in which case the user will be required to correct the interference at his/her own expense. The user is advised that any equipment changes or modifications not expressly approved by the party responsible for compliance would void the compliance to FCC regulations and therefore, the user's authority to operate the equipment.

**Caution!** *There is a danger of a new battery exploding if it is incorrectly installed. Do not attempt to recharge, force open, or heat the battery. Replace the battery only with the same or equivalent type recommended by the manufacturer. Discard used batteries according to the manufacturer's instructions.*



---

## Technical Support

If a problem arises with your system and no solution can be obtained from the user's manual, please contact your place of purchase or local distributor. Alternatively, please try the following help resources for further guidance. Visit the Advantech website for FAQ, technical guide, BIOS updates, driver updates, and other information:

<http://support.advantech.com.tw/Support/default.aspx>

## Packing List

Before you begin installing your single board, please make sure that the following materials have been shipped:

- 1 x AIMB-252 (910GMLE) (or AIMB-252(915GME)) Mini ITX Main board
- 1 x CD-ROM contains the followings:
  - User's manual (this manual in PDF file)
  - Drivers
- 1 x IDE HDD cable (40-pin)
- 2 x COM cable
- 2 x SATA Data cables
- 2 x SATA Power cables
- 1 x Startup Manual
- 1 x CPU cooler
- 1 x I/O Shield

If any of the above items is damaged or missing, please contact your retailer.

# Contents

<b>Chapter 1</b>	<b>Production Introduction.....</b>	<b>1</b>
1.1	Before You Proceed.....	2
1.2	Motherboard Overview.....	2
1.2.1	Placement Direction.....	2
1.2.2	Screw Holes.....	3
1.3	Motherboard Layout.....	4
	Figure 1.1 Motherboard Layout .....	4
1.4	Specifications.....	5
1.5	Board Diagram.....	7
1.6	Ordering Information.....	8
1.7	Riser Card.....	8
1.8	Bracket View.....	8
1.9	Accessories.....	8
1.10	Layout Content List.....	9
	Table 1.1: Slots.....	9
	Table 1.2: Rear Panel Connector.....	9
	Table 1.3: Internal Connector.....	9
	Table 1.4: CMOS1.....	10
	Table 1.5: ATX/AT mode selector(JPSON1).....	10
	Table 1.6: COM1 RS-232/422/485 mode selector (JSETCOM1).....	11
1.11	Central Processing Unit (CPU) (for AIMB-252(915GME) only).....	11
1.11.1	Installing the CPU.....	12
1.11.2	Installing the CPU Heatsink and Fan.....	14
1.11.3	Uninstalling the CPU Heatsink and Fan.....	16
1.12	System Memory.....	16
1.12.1	DIMM Sockets Location.....	16
1.12.2	Memory Configurations.....	17
1.12.3	Installing a DDR2 DIMM.....	18
1.12.4	Removing a DDR2 DIMM.....	19
1.13	Expansion Slots.....	19
1.13.1	Installing an Expansion Card.....	19
1.13.2	Configuring an Expansion Card.....	19
1.13.3	Standard Interrupt Assignments.....	20
	Table 1.7: Standard Interrupt Assignments.....	20
1.13.4	PCI Slots.....	20
1.14	Connectors.....	21
1.14.1	Rear Panel Connectors.....	21
	Table 1.8: Rear Panel Connectors.....	21
	Table 1.9: LEDs.....	21
1.14.2	CPU Fan Connector (CPUFAN1).....	22
1.14.3	System Fan Connector (SYSFAN1).....	23
1.14.4	Serial Port Connector 23 (COM23).....	24
1.14.5	Serial Port Connector 45 (COM45).....	24
1.14.6	Front Headphone Connector (FPAUD1).....	25
1.14.7	Front Panel Connector (JFP1/JFP2/JFP3).....	26
1.14.8	ATX soft power switch (JFP1 / PWR_SW).....	26
1.14.9	Reset (JFP1 / RESET).....	26
1.14.10	HDD LED (JFP2 / HDDLED).....	26
1.14.11	External speaker (JFP2 / SPEAKER).....	26
1.14.12	Power LED and keyboard lock connector (JFP3 / PWR_LED&KEY LOCK).....	27
	Table 1.10:ATX power supply LED status (No support for AT power).....	27

	1.14.13USB 2.0 Connector (USB56, USB78).....	27
	1.14.14ATX Power Connector (EATXPWR1).....	28
	1.14.15LCD Inverter Connector (INV1) & LVDS (INV2) .....	29
	1.14.16LVDS Connector (LVDS1).....	31
	1.14.17LVDS Connector (LVDS2).....	31
	1.14.18Digital I/O Connector (GPIO1).....	32
	1.14.19Serial ATA Connector 1 & 2 (SATA1, SATA2) .....	32
<b>Chapter 2</b>	<b>BIOS Operation .....</b>	<b>33</b>
2.1	BIOS Introduction.....	34
2.2	BIOS Setup .....	34
2.2.1	Main Menu .....	35
2.2.2	Standard CMOS Features .....	36
2.2.3	Advanced BIOS Features .....	37
2.2.4	Advanced Chipset Features .....	38
2.2.5	Integrated Peripherals .....	40
2.2.6	Power Management Setup .....	42
2.2.7	PnP/PCI Configurations.....	44
2.2.8	PC Health Status .....	45
2.2.9	Frequency/voltage Control.....	46
2.2.10	Load Setup Defaults .....	46
2.2.11	Set Password.....	47
2.2.12	Save & Exit Setup.....	49
2.2.13	Quit Without Saving.....	49
<b>Chapter 3</b>	<b>Chipset Software Install Utility .....</b>	<b>51</b>
3.1	Before you Begin .....	52
3.2	Introduction .....	52
3.3	Windows XP Driver Setup.....	53
<b>Chapter 4</b>	<b>VGA Setup .....</b>	<b>55</b>
4.1	Introduction .....	56
4.2	Windows XP Driver Setup.....	56
<b>Chapter 5</b>	<b>LAN Configuration .....</b>	<b>59</b>
5.1	Introduction .....	60
5.2	Features.....	60
5.3	Installation.....	60
5.4	Win XP Driver Setup (Realtek RTL8111C).....	60
<b>Appendix A</b>	<b>Programming the Watchdog.....</b>	<b>63</b>
A.1	Programming the Watchdog Timer .....	64
A.1.1	Watchdog timer overview .....	64
A.1.2	Programming the Watchdog Timer.....	64
	Table A.1: Watchdog Timer Registers.....	66
A.1.3	Example Program .....	67
<b>Appendix B</b>	<b>Pin Assignments.....</b>	<b>71</b>
B.1	IDE Hard Drive Connector (IDE1).....	72

	Table B.1: IDE Hard Drive Connector (IDE1) .....	72
B.2	Parallel Port Connector (LPT1) .....	73
	Table B.2: Parallel Port Connector (LPT1) .....	73
B.3	USB Connector (USB56,USB78) .....	73
	Table B.3: USB5/USB6 Connector (USB56) .....	73
B.4	VGA Connector (VGA1) .....	74
	Table B.4: VGA Connector (VGA1) .....	74
B.5	RS-232 Serial Port (COM1) .....	74
	Table B.5: Rs-232 Serial Port (COM1) .....	74
B.6	RS-232 Serial Port (COM2 ~ COM5) .....	75
	Table B.6: RS-232 Serial Port (COM23) .....	75
	Table B.7: RS-232 Serial Port (COM45) .....	75
B.7	PS/2 Keyboard/ Mouse Connector (KBMS1) .....	76
	Table B.8: PS/2 Keyboard/ Mouse Connector (KBMS1) .....	76
B.8	CPU Fan Power Connector (CPUFAN1) .....	76
	Table B.9: CPU Fan Power Connector (CPUFAN1) .....	76
B.9	Power LED & Keyboard Lock Connector (JFP3) .....	77
	Table B.10: Power LED and Keylock Connector (JFP3) .....	77
B.10	External Speaker Connector (JFP2/ SPEAKER) .....	77
	Table B.11:External Speaker Connector (JFP2/SPEAKER).....	77
B.11	Reset Connector (JFP1/ RESET) .....	78
	Table B.12:Reset Connector (JFP1/ RESET).....	78
B.12	HDD LED Connector (JFP2/ HDDLED) .....	78
	Table B.13:HDD LED Connector (JFP2/ HDDLED).....	78
B.13	ATX Soft Power Switch (JFP1/ PWR_SW) .....	78
	Table B.14:ATX Soft Power Switch (JFP1/ PWR_SW) .....	78
B.14	AC-97 Audio Interface (FPAUD1) .....	79
	Table B.15:AC-97 Audio Interface (FPAUD1).....	79
B.15	SM Bus Connector (JFP2) .....	79
	Table B.16:SM Bus Connector (JFP2).....	79
B.16	GPIO Pin Header (GPIO1) .....	80
	Table B.17:GPIO Pin Header (GPIO1) .....	80
B.17	LVDS Connector (LVDS1/LVDS2) .....	81
	Table B.18:LVDS Connector (LVDS1/2).....	81
B.18	LVDS Power Jumper (JLV1, JLV2) .....	82
	Table B.19:LVDS Power Jumper (JLV1, JLV2) .....	82
B.19	LVDS Invert (INV1, INV2) .....	82
	Table B.20:LVDS Invert (INV1, INV2).....	82
B.20	System I/O Ports .....	83
	Table B.21:System I/O Ports .....	83
B.21	DMA Channel Assignments .....	83
	Table B.22:DMA Channel Assignments.....	83
B.22	Interrupt Assignments .....	84
	Table B.23:Interrupt Assignments.....	84
B.23	1st MB Memory Map .....	84
	Table B.24:1st MB Memory Map .....	84
B.24	PCI Bus Map .....	84
	Table B.25:PCI Bus Map .....	84





# Chapter 1

## Production Introduction

This chapter describes the main board features and the new technologies it supports.

## 1.1 Before You Proceed

Take note of the following precautions before you install motherboard components or change any motherboard settings.

**Caution!**



- *Unplug the power cord from the wall socket before touching any component.*
- *Use a grounded wrist strap or touch a safely grounded object or a metal object, such as the power supply case, before handling components to avoid damaging them due to static electricity*
- *Hold components by the edges to avoid touching the ICs on them.*
- *Whenever you uninstall any component, place it on a grounded antistatic pad or in the bag that came with the component.*
- *Before you install or remove any component, ensure that the ATX power supply is switched off or the power cord is detached from the power supply. Failure to do so may cause severe damage to the motherboard, peripherals, and/or components.*

## 1.2 Motherboard Overview

Before you install the motherboard, study the configuration of your chassis to ensure that the motherboard fits into it. Refer to the chassis documentation before installing the motherboard.

**Warning!**



*Make sure to unplug the power cord before installing or removing the motherboard. Failure to do so can cause you physical injury and damage motherboard components.*

### 1.2.1 Placement Direction

When installing the motherboard, make sure that you place it into the chassis in the correct orientation. The edge with external ports goes to the rear part of the chassis as indicated in the image below.

### 1.2.2 Screw Holes

Place four (4) screws into the holes indicated by circles to secure the motherboard to the chassis.

**Caution!** Do not over tighten the screws! Doing so can damage the motherboard.

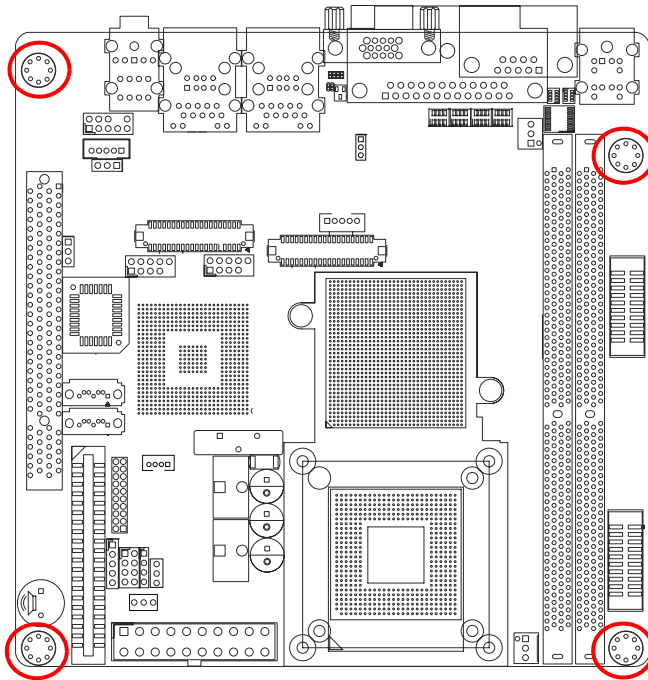

Place this side towards the rear of the chassis.

## 1.3 Motherboard Layout

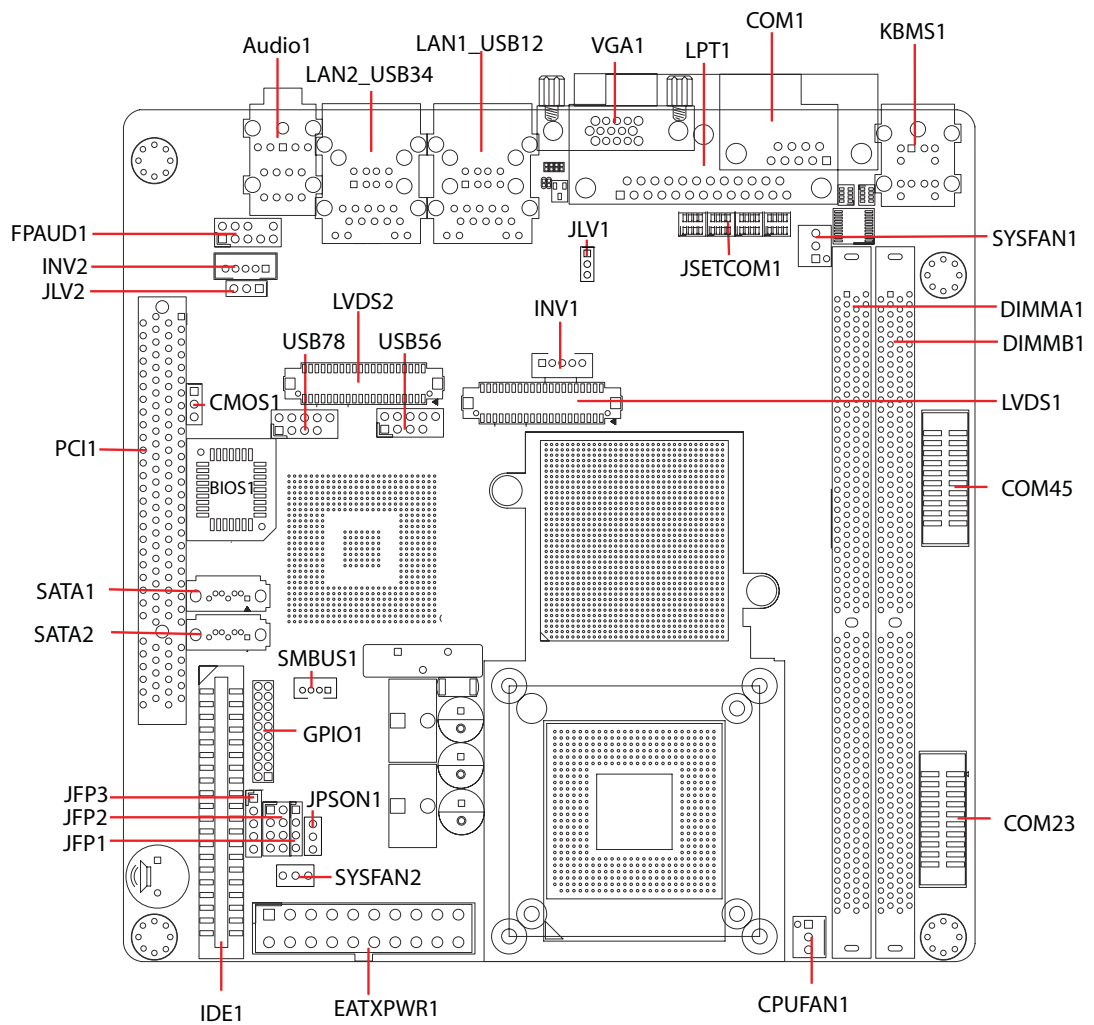

Figure 1.1 Motherboard Layout

## 1.4 Specifications

	CPU (130/90 nm, $\mu$ FC-PGA 478)	Intel Pentium M	Intel Celeron M	Celeron M	Celeron M
Processor Ssystem	Max. Speed	2.0 GHz	1.5 GHz	1 GHz	600 MHz
	Front Side Bus	400/533 MHz	400 MHz	400 MHz	400 Mhz
	L2 Cache	2 MB	1 MB	0 MB	0 MB
	Chipset	Intel 910GMLE*/915GME + ICH6M			
	BIOS	Award 4 Mbit FWH			
Expansion Slot	PCI	32-bit/33 MHz, 1 slot			
	Mini-PCI	-			
	PCIe	-			
Memory	Technology	Dual Channel DDR2 400/533 SDRAM			
	Max. Capacity	2 GB			
	Socket	240-pin DIMM x 2			
Graphics	Controller	Intel 910GMLE/915GME GMCH integrated Graphics Media Accelerator 900			
	VRAM	Intel DVMT 3.0 supports up to 128 MB video memory			
	1st LVDS	Single channel 18-bit/Dual channel 36-bit LVDS			
	2nd LVDS	Single channel 18/24-bit/Dual channel 36/48-bit LVDS, via Chrontel 7308B SDVO transmitter			
	DVI	None			
	Dual Display	VGA + LVDS, LVDS + LVDS			
Ethernet	Interface	10/100/1000Base -T			
	Controller	GbE LAN1: Realtek RTL8111C; GbE LAN2: Realtek RTL8111C			
	Connector	RJ-45 x 2			
SATA	Max Data Transfer Rate	150 MB/s			
	Channel	2			
EIDE	Mode	EIDE (Ultra DMA 100)			
	Channel	1			
SSD	Compact Flash	Supports compact flash type I/II			
Rear I/O	VGA	1			
	Ethernet	1 (for VG version); 2 (for G2 version)			
	USB	4 (USB 2.0 compliant)			
	Audio	MIC-In, Line-Out, Line-in			
	Serial	1 (RS-232/422/485)			
	Parallel	1			
	PS/2	2 (1 x keyboard and 1 x mouse)			

	LVDS & Inverter	2			
Internal Connector	USB	4 (USB 2.0 compliant)			
	Serial	4 (RS-232)			
	IDE	1			
	SATA	2			
	Compact Falsh	1			
	IrDA	-			
	DIO	16-bit GPIO			
Watchdog Timer	Output	Interrupt, system reset			
	Interval	Programmable 1 ~ 255 sec/ min			
Power Requirement	Typical	Intel 915GME and Pentium M 760 2.0 GHz FSB 533 MHz, 2 GB DDR2 SDRAM			
		+5 V	+3.3 V	+12 V	+5 V <sub>SB</sub>
		2.61 A	0.71 A	1.93 A	0.59 A
Environment		Operating			
	Temperature	0 ~ 60° C (32 ~ 140° F)			
Physical Characteristics	Dimensions	170 mm x 170 mm (6.69" x 6.69")			
* Intel 910GMLE only supports FSB 400 processor and DDR2 400 SDRAM					

## 1.5 Board Diagram

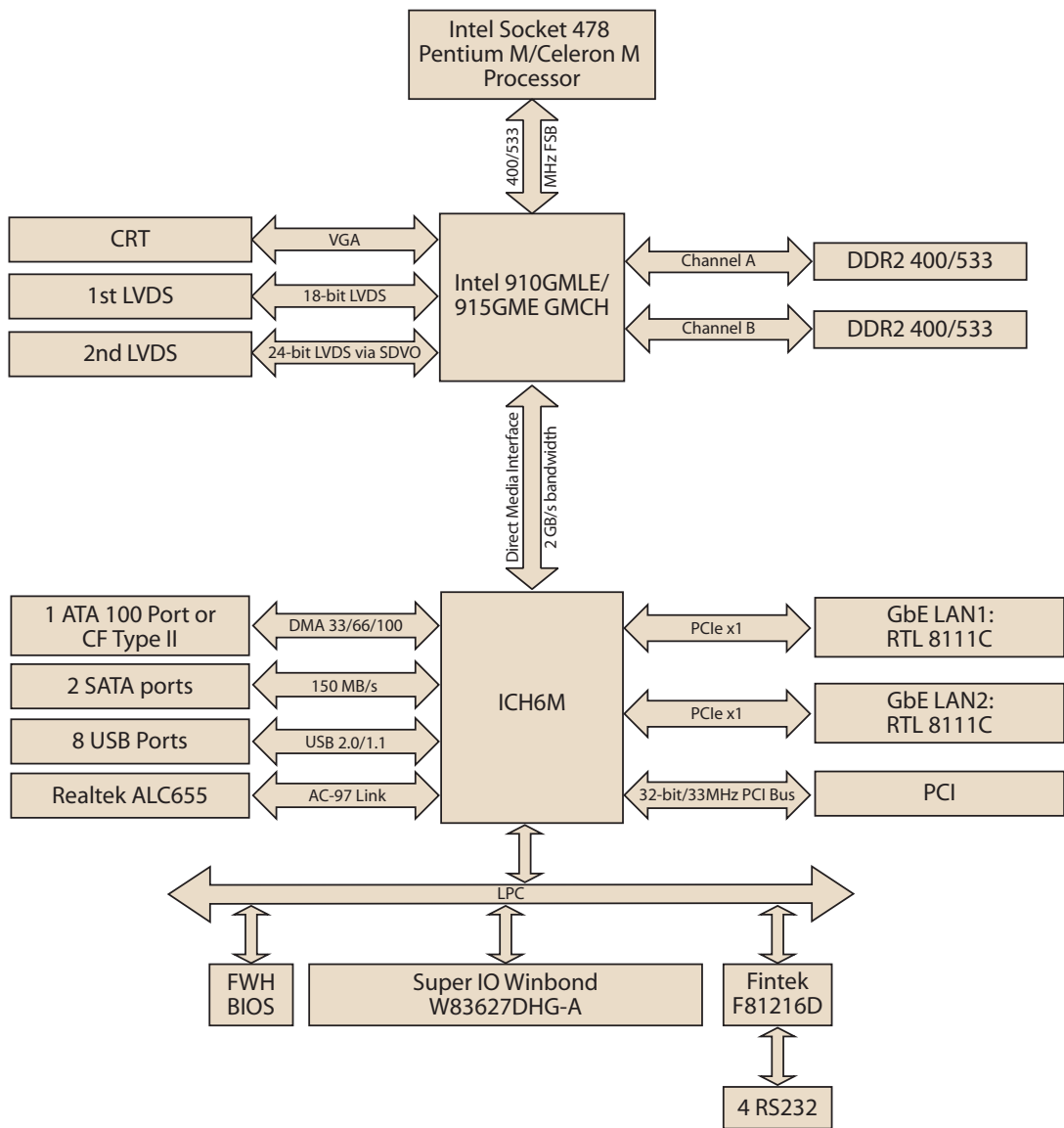

## 1.6 Ordering Information

Part Number	CPU	Chipset	DDR2	GbE	COM	LVDS
AIMB-252VG-M0A1E	Celeron M 600	910GMLE	400	1	5	Single
AIMB-252G2-00A1E	socket type	915GME	400/533	2	5	Single
AIMB-252G2-M0A1E	Celeron M 600	910GMLE	400	2	5	Dual
AIMB-252VG-S0A1E	Celeron M 1Ghz	910GMLE	400	1	5	Single

## 1.7 Riser Card

Part Number	Description
AIMB-RP30P-03A1E	2U riser card with 3 PCI slot expansion

## 1.8 Bracket View



AIMB-252VG-M0A1E

AIMB-252G2-00A1E  
AIMB-252G2-M0A1E

## 1.9 Accessories

Part Number	Description
1700003195	USB cable with four ports, 17.5 cm
1700002204	USB cable with four ports, 27 cm
1700002314	USB cable with four ports, 30.5 cm



## 1.10 Layout Content List

**Table 1.1: Slots**

Label	Function	Note
DIMMA1	240-pin DDR2 DIMM slot	
DIMMB1	240-pin DDR2 DIMM slot	
PCI1	PCI slot	

**Table 1.2: Rear Panel Connector**

Label	Function	Note
KBMS1	PS/2 keyboard and mouse	6-pin Mini-Din
COM1	Serial port connector x 1	D-sub 9-pin, male
LPT1	Parallel port, Parallel port x 1	25-pin port connector
LAN1_USB12	RJ-45 Ethernet connector x 1 USB connector x 2	
LAN2_USB34	RJ-45 Ethernet connector x 1 USB connector x 2	
AUDIO1	Line-in port, Line-out port, Microphone port	6-Channel Audio I/O (3 jacks)

**Table 1.3: Internal Connector**

Label	Function	Note
CPUFAN1	CPU fan connector	3 x 1 wafer, pitch 2.54 mm
SYSFAN1	System fan connector	3 x 1 wafer, pitch 2.54 mm
SYSFAN2	System fan connector	3 x 1 wafer, pitch 2.54 mm
COM23	Serial port connector 2,3	5 x 2 header, pitch 2.0 mm
COM45	Serial port connector 4,5	5 x 2 header, pitch 2.0 mm
FPAUD1	Front headphone connector	5 x 2 header, pitch 2.54 mm
USB56	USB 2.0 connector	5 x 2 header, pitch 2.54 mm
USB78	USB 2.0 connector	5 x 2 header, pitch 2.54 mm
IDE1	Primary IDE connector	20 x 2 header, pitch 2.54 mm
ATX	ATX power connector	10 x 2 header
INV1	LCD Inverter connector	5 x 1 header, pitch 2.00 mm
INV2	LCD Inverter connector	5 x 1 header, pitch 2.00 mm
LVDS1	LVDS connector	HIROSE DF13S-40DP-1.25V
LVDS2	LVDS connector	HIROSE DF13S-40DP-1.25V

**Table 1.3: Internal Connector**

SATA1	Serial ATA connectors	7-pin header
<b>Label</b>	<b>Function</b>	<b>Note</b>
SATA2	Serial ATA connectors	7-pin header
JFP3	Keyboard lock and power LED	Suspend: Fast flash (ATX/AT) System On: on (ATX/AT) System Off: off (AT) System Off: slow flash (ATX)
JFP2	External speaker / SATA HDD LED connector / SM Bus connector	
JFP1	Power switch / reset connector	

**Table 1.4: CMOS1**

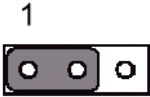
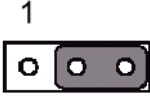
<b>COMS1</b>	<b>Clear CMOS</b>	
*Keep COMS data		1-2 closed
Clear CMOS data		2-3 closed
*Default setting		

**Table 1.5: ATX/AT mode selector(JPSON1)**

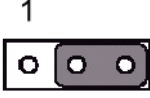
<b>JPSON1</b>	<b>AT(1-2) / ATX(2-3)</b>	
AT Mode		1-2 closed
*ATX Mode		2-3 closed
*Default setting		

**Table 1.6: COM1 RS-232/422/485 mode selector (JSETCOM1)**

JSETCOM1	COM1 RS-232/422/485 jumper setting
----------	------------------------------------

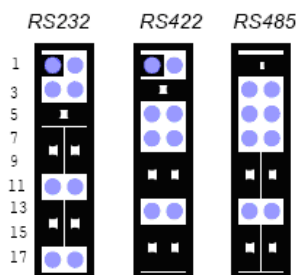

## 1.11 Central Processing Unit (CPU) (for AIMB-252(915GME) only)

The motherboard AIMB-252 (915GME) comes with a surface mount 478-pin Zero Insertion Force (ZIF) socket designed for the Intel® Pentium® M / Celeron® M processor (Supports mPGA478M, Micro-FCPGA).

Take one of the marked corner (with gold triangle) on the CPU. This mark should match a specific corner on the socket to ensure correct installation.

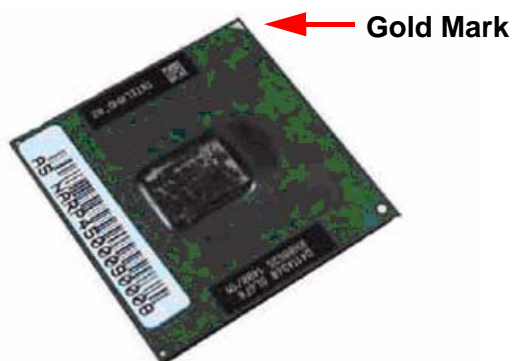

- Note!**
- Make sure the AC power is off before you install the CPU.
  - If installing a dual-core CPU, connect the CPU fan cable to the CPUFAN1 connector to ensure system stability.



**Caution!**



- Intel® socket 478 Pentium M/ Celeron M CPU with 90nm process package should come with installation instructions for the CPU, heatsink, and the retention mechanism. If the instructions in this section do not match the CPU documentation, follow the latter.
- Upon purchase of the motherboard, make sure that the PnP cap is on the socket and the socket contacts are not bent. Contact your retailer immediately if the PnP cap is missing, or if you see any damage to the PnP cap/socket contacts/motherboard components. Your place of purchase or local distributor will shoulder the cost of repair only if the damage is shipment/transit-related.
- Keep the cap after installing the motherboard. Your place of purchase or local distributor will process Return Merchandise Authorization (RMA) requests only if the motherboard comes with the cap on the socket.
- The product warranty does not cover damage to the socket contacts resulting from incorrect CPU installation/removal, or misplacement/loss/ incorrect removal of the PnP cap.

### 1.11.1 Installing the CPU

1. Locate the CPU socket on the motherboard.

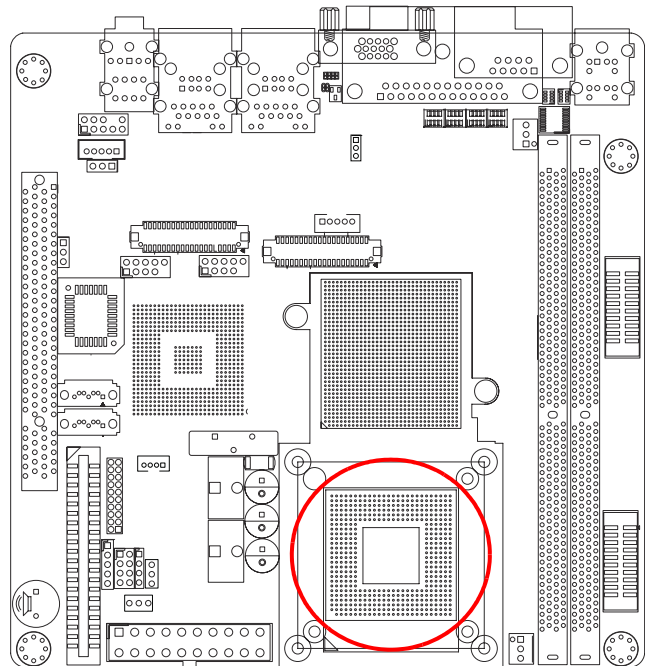

**Note!** Before installing the CPU, make sure that the socket box is facing towards you.



- The processor socket comes with a screw to secure the processor, please unlock the screw first.

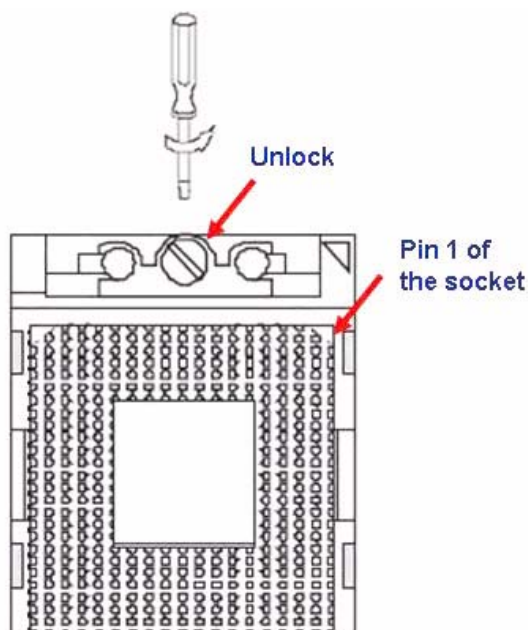

- Position the CPU above the socket and the gold triangular mark on the CPU must align with pin 1 of the CPU socket.
- Carefully insert the CPU into the socket until it fits in place 'Gold mark'.
- Turn the screw to the lock position.

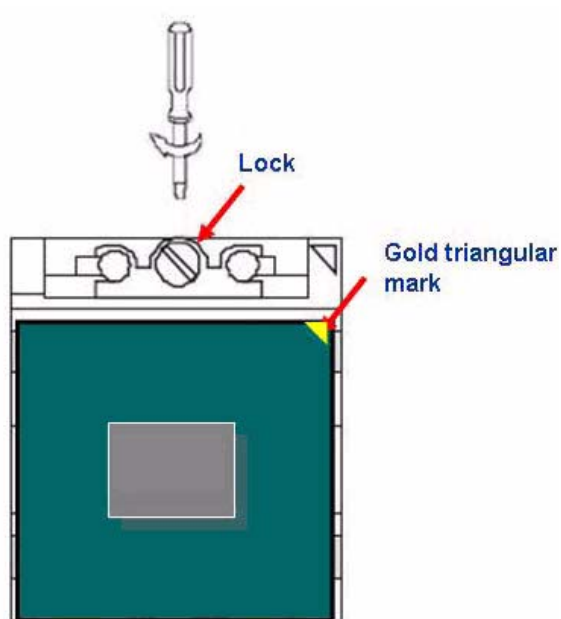

**Warning!** The CPU fits in only one correct orientation. DO NOT force the CPU into the socket to prevent bending the connectors on the socket and damaging the CPU.



**Warning!** After installation, make sure to plug-in the ATX power cable to the motherboard.



### 1.11.2 Installing the CPU Heatsink and Fan

The Intel® Pentium® M / Celeron® M processor (supports mPGA478M, Micro-FCPGA) requires a specially designed heatsink and fan assembly to ensure optimum thermal condition and performance.

**Caution!** If you purchased a separate CPU heatsink and fan assembly, make sure that you have properly applied Thermal Interface Material to the CPU heatsink or CPU before you install the heatsink and fan assembly.



1. Place the heatsink on top of the installed CPU, making sure that the four screws match the holes on the motherboard.

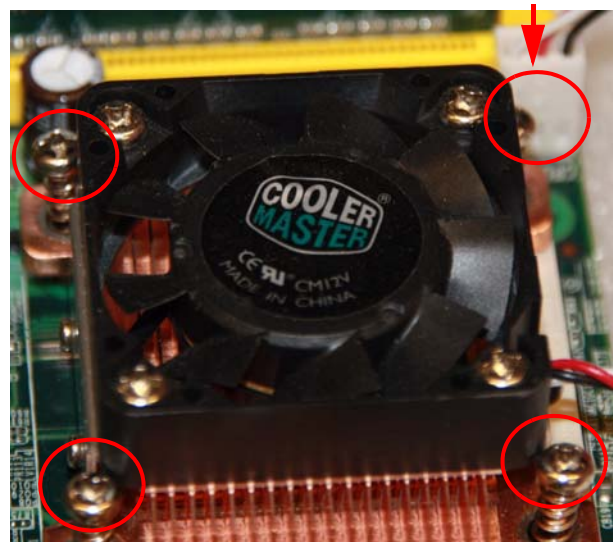
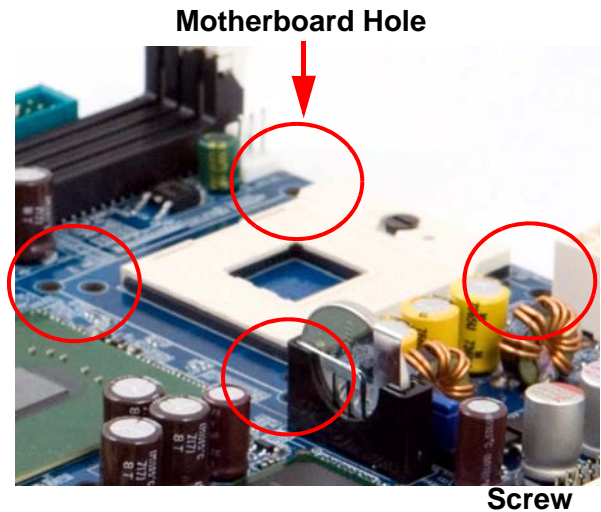

**Note!** Orient the heatsink and fan assembly such that the CPU fan cable is closest to the CPU fan connector.



2. Connect the CPU fan cable to the connector on the motherboard labelled CPUFAN1.

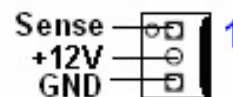
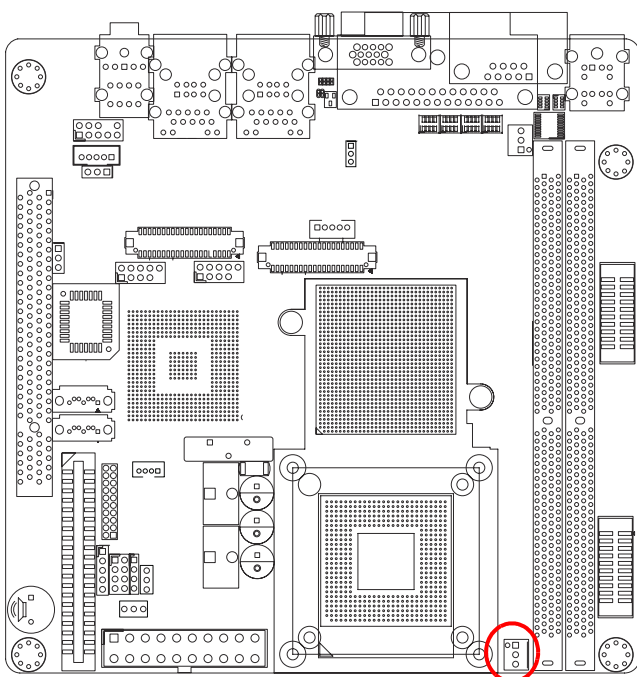

**Caution!** ■ Do not forget to connect the fan cables to the fan connectors. Insufficient air flow inside the system may damage the motherboard components, and hardware monitoring errors can occur if you fail to plug this connector.



- These are not jumpers! DO NOT place jumper caps on the fan connectors.



### 1.11.3 Uninstalling the CPU Heatsink and Fan

1. Disconnect the CPU fan cable from the connector on the motherboard.
2. Rotate each screw counter-clockwise.

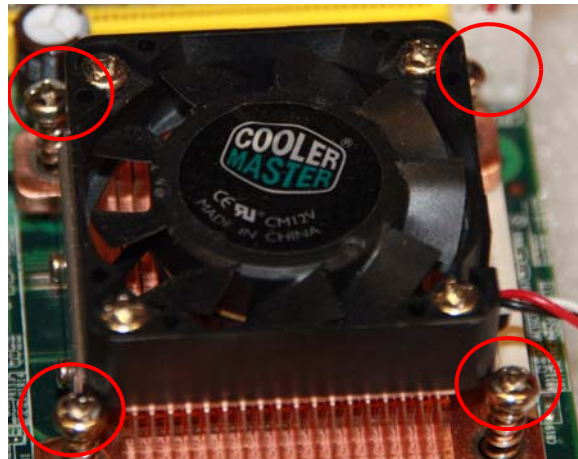

3. Carefully remove the heatsink and fan assembly from the motherboard.

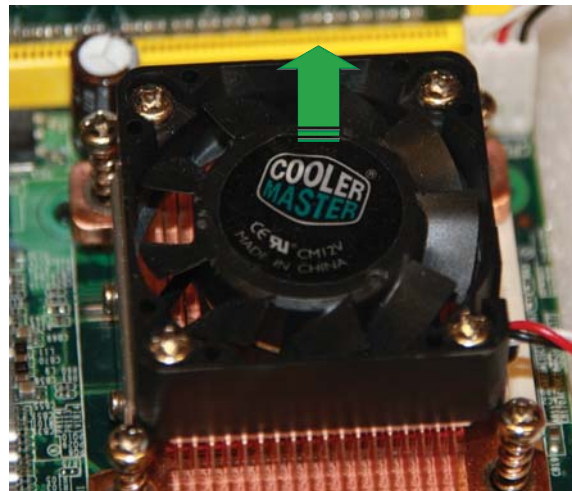

**Note!** Refer to the documentation in the boxed or stand-alone CPU fan package for detailed information on CPU fan installation.



## 1.12 System Memory

### 1.12.1 DIMM Sockets Location

The motherboard comes with two 240-pin Double Data Rate 2 (DDR2) Dual Inline Memory Modules (DIMM) sockets.

A DDR2 module has the same physical dimensions as a DDR DIMM but has a 240-pin footprint compared to the 240-pin DDR DIMM. DDR2 DIMMs are notched differently to prevent installation on a DDR DIMM socket. The following figure illustrates the location of the sockets:



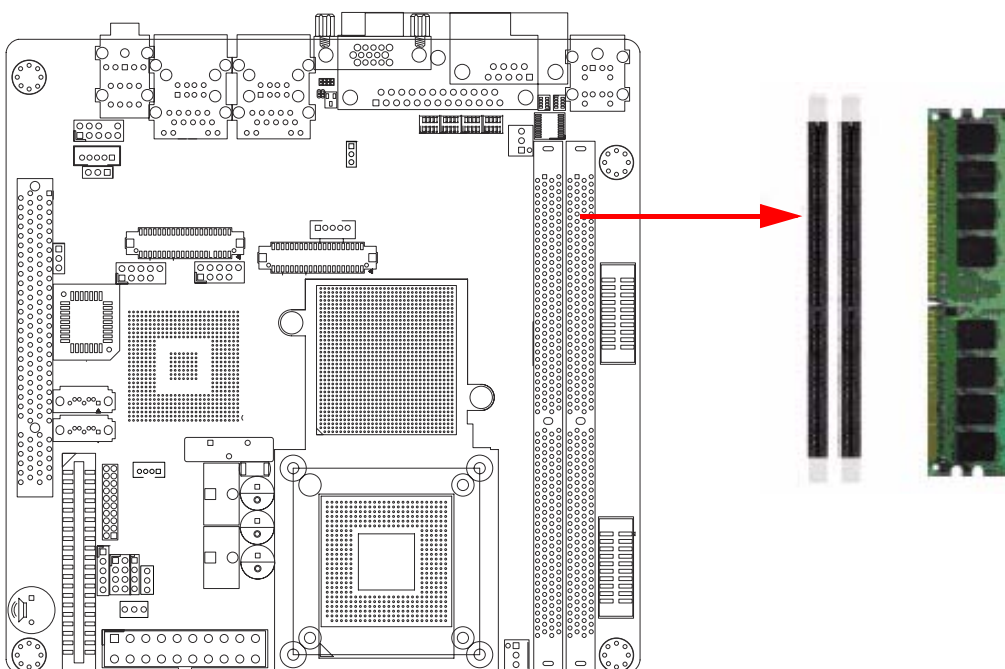

### 1.12.2 Memory Configurations

You can install 128 MB, 256 MB, 512 MB, 1GB and 2GB DDR2 SDRAM DIMMs into the SODIMM sockets using the memory configurations in this section.

#### Note!



- *Installing DDR2 DIMM other than the recommended configurations may cause memory sizing error or system boot failure. Use any of the recommended configurations.*
- *Always install DIMMs with the same CAS latency. For optimum compatibility, it is recommended that you obtain memory modules from the same vendor.*
- *Due to chipset resource allocation, the system may detect less than 1 GB system memory when you installed one 1 GB DDR2 memory modules.*
- *This motherboard does not support memory modules made up of 128 MB chips or double-sided x16 memory modules.*
- *Make sure that the memory frequency matches the CPU FSB (Front Side Bus). Refer to the Memory frequency/CPU FSB synchronization table.*

**Note!** ■ Recommended memory configuration.



### Sockets

Mode	DIMM1	
Single-channel	(1) Install	-
	(2) -	Install

■ CPU FSB/Memory frequency synchronization.

CPU FSB	DDR 2 DIMM Type	Memory Frequency
533 MHz	DDR2 533	533 MHz
	DDR2 400	400 MHz
400 MHz	DDR2 533	400 MHz
	DDR2 400	400 MHz

## 1.12.3 Installing a DDR2 DIMM

**Caution!** Make sure to unplug the power supply before adding or removing DIMMs or other system components. Failure to do so may cause severe damage to both the motherboard and the components.



1. Unlock a DIMM socket by pressing the retaining clips outward
2. Align a DIMM on the socket such that the notch on the DIMM matches the break on the socket.
3. Firmly insert the DIMM into the socket until the retaining clips snap back in place and the DIMM.

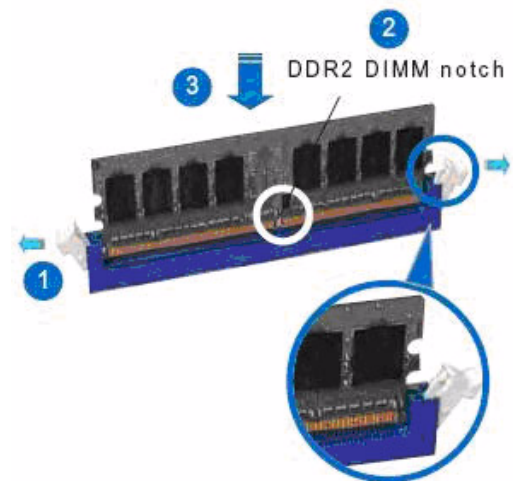

Unlocked retaining clip

**Caution!** ■ A DDR2 DIMM is keyed with a notch so that it fits in only one direction. DO NOT force a DIMM into a socket to avoid damaging the DIMM.



■ The DDR2 DIMM sockets do not support DDR DIMMs. DO NOT install DDR DIMMs to the DDR2 DIMM socket.

### 1.12.4 Removing a DDR2 DIMM

1. Simultaneously press the retaining clips outward to unlock the DIMM.
2. Remove the DIMM from the socket.

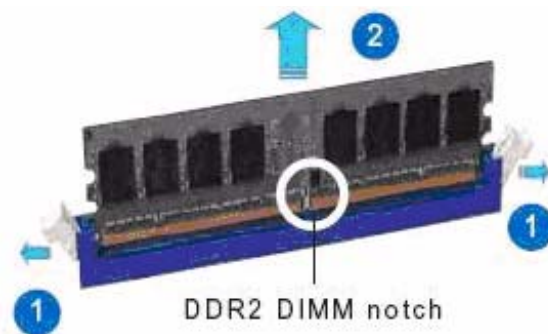

**Caution!** Support the DIMM lightly with your fingers when pressing the ejector tabs. The DIMM might get damaged when it flips out with extra force.



## 1.13 Expansion Slots

In the future, you may need to install expansion cards. The following subsections describe the slots and the expansion cards that they support.

**Warning!** Make sure to unplug the power cord before adding or removing expansion cards. Failure to do so may cause you physical injury and damage motherboard components.



### 1.13.1 Installing an Expansion Card

1. Before installing the expansion card, read the documentation that came with it and make the necessary hardware settings for the card.
2. Remove the system unit cover (if your motherboard is already installed in a chassis).
3. Remove the bracket opposite the slot that you intend to use. Keep the screw for later use.
4. Align the card connector with the slot and press firmly until the card is completely seated on the slot.
5. Secure the card to the chassis with the screw you removed earlier.
6. Replace the system cover.

### 1.13.2 Configuring an Expansion Card

After installing the expansion card, configure it by adjusting the software settings.

1. Turn on the system and change the necessary BIOS settings if any.
2. Assign an IRQ to the card if needed. Refer to the tables on the next page.
3. Install the software drivers for the expansion card.

### 1.13.3 Standard Interrupt Assignments

**Table 1.7: Standard Interrupt Assignments**

IRQ	Priority	Standard Function
0	1	System Timer
1	2	Keyboard Controller
2	-	Redirect to IRQ#9
3	11	COM5
5	13	IRQ holder for PCI steering*
6	14	Floppy Disk Controller
8	3	COM2
9	4	COM1
10	5	COM3
11	6	IRQ holder for PCI steering*
12	7	PS/2 Compatible Mouse Port*
13	8	Numeric Data Processor
14	9	Primary IDE Channel
15	10	COM4

\*These IRQs are usually available for ISA or PCI device.

### 1.13.4 PCI Slots

AIMB-252 has one PCI slots. The PCI slots support cards such as a LAN card, SCSI card, USB card, and other cards that comply with PCI specifications. The figure shows a LAN card installed on a PCI slot.

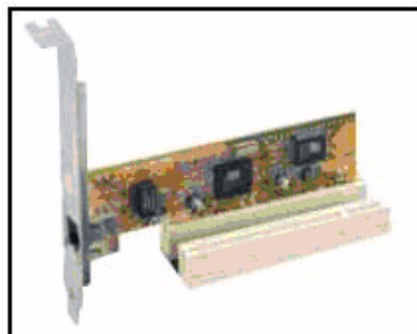

## 1.14 Connectors

### 1.14.1 Rear Panel Connectors

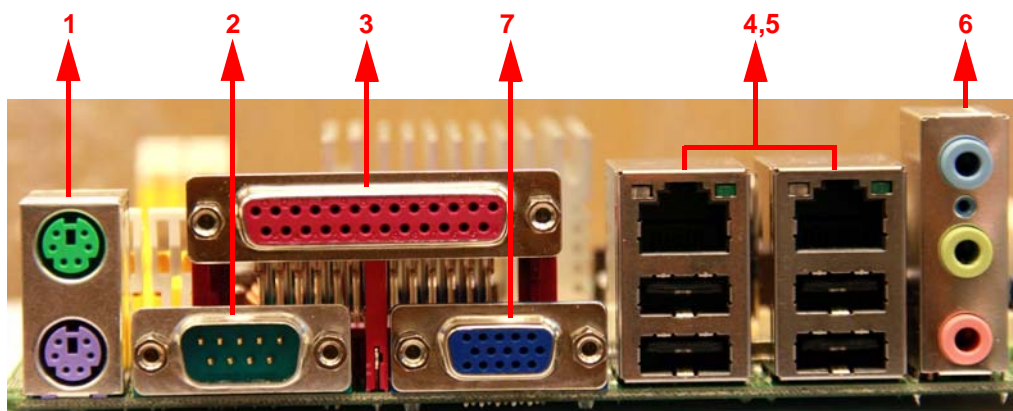

**Table 1.8: Rear Panel Connectors**

No	Label	Function	Description
1	KBMS1	PS/2 mouse connector	The standard PS/2 mouse DIN connector is for a PS/2 mouse.
2	COM1	Serial port connector x 1	D-sub 9-pin, male
3	Parallel port	Parallel port	
4,5	LAN1_USB12/ LAN2_USB34	LAN (RJ-45) connector	This port allows Gigabit connection to a Local Area Network (LAN) through a network hub. Refer to the table below for the LAN port LED indications. The optional 10/100 Mbps LAN controller allows 10/100 Mbps connection to a Local Area Network (LAN) through a network hub.
<p>The diagram shows a close-up of a LAN port with two LEDs above it. The left LED is labeled 'SPEED LED' and the right LED is labeled 'ACT/LINK LED'. Below the diagram is the text 'LAN port'.</p>			
6	Audio1	3 ports audio connector	Mic-in, Line-in, Line-out
7	VGA	VGA port	

**Table 1.9: LEDs**

ACT / LINK LED		SPEED LED	
Status	Description	Status	Description
OFF	No link	OFF	10 Mbps connection
Green	Linked	ORANGE	100 Mbps connection
Blinking	Data activity	GREEN	1 Gbps connection

## 1.14.2 CPU Fan Connector (CPUFAN1)

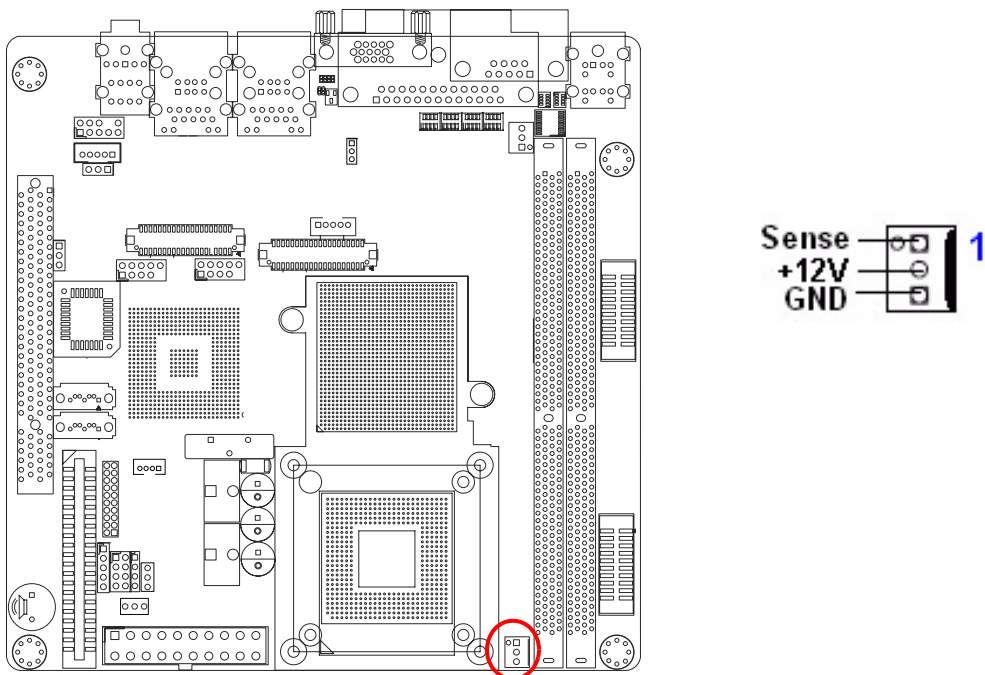

- Caution!** ■ Do not forget to connect the fan cables to the fan connectors. Insufficient air flow inside the system may damage the motherboard components, and hardware monitoring errors can occur if you fail to plug this connector.
- These are not jumpers! DO NOT place jumper caps on the fan connectors.



### 1.14.3 System Fan Connector (SYSFAN1)

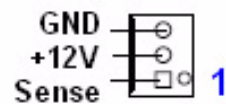
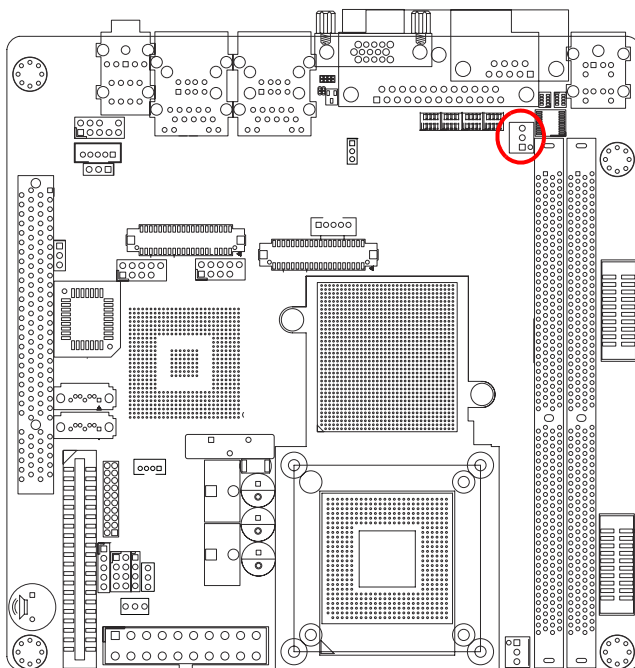

- Caution!** 
- Do not forget to connect the fan cables to the fan connectors. Insufficient air flow inside the system may damage the motherboard components, and hardware monitoring errors can occur if you fail to plug this connector.
  - These are not jumpers! DO NOT place jumper caps on the fan connectors.



### 1.14.4 Serial Port Connector 23 (COM23)

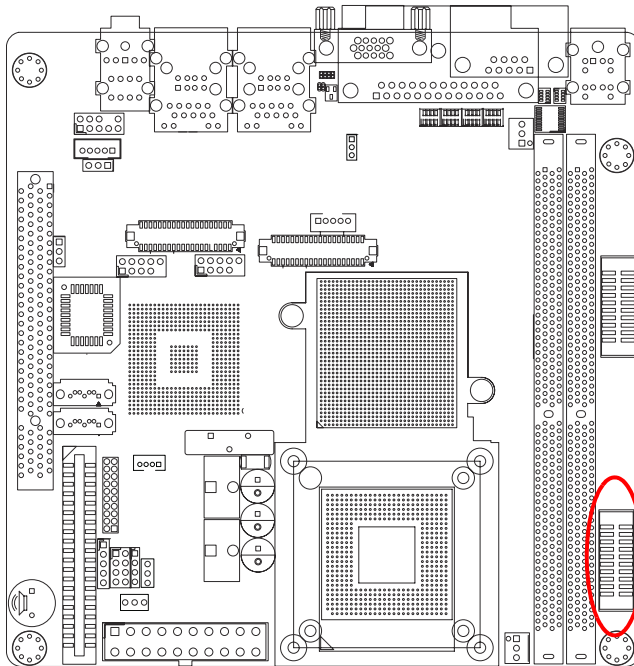

1

DDCD2_N	□	○	DDSR2_N
RRXD2	○	○	RRTS2_N
TTXD2	○	○	CCTS2_N
DDTR2_N	○	○	RII2_M
GND	○	○	GND
DDCD3_N	○	○	DDSR3_N
RRXD3	○	○	RRTS3_N
TTXD3	○	○	CCTS3_N
DDTR3_N	○	○	RII3_N
GND	○	○	GND

### 1.14.5 Serial Port Connector 45 (COM45)

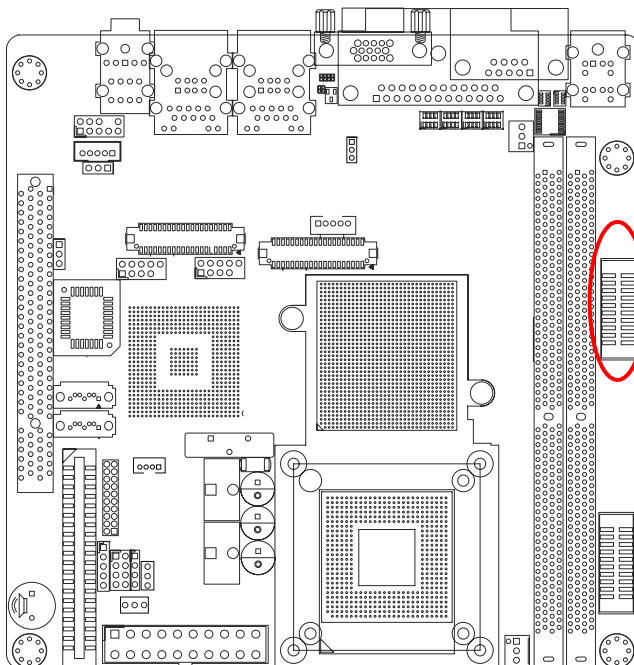

1

DDCD4_N	□	○	DDSR4_N
RRXD4	○	○	RRTS4_N
TTXD4	○	○	CCTS4_N
DDTR4_N	○	○	RII4_M
GND	○	○	GND
DDCD5_N	○	○	DDSR5_N
RRXD5	○	○	RRTS5_N
TTXD5	○	○	CCTS5_N
DDTR5_N	○	○	RII5_N
GND	○	○	GND



### 1.14.6 Front Headphone Connector (FPAUD1)

This connector is for a chassis-mounted front panel audio I/O module that supports either HD Audio or legacy AC'97 (optional) audio standard. Connect one end of the front panel audio I/O module cable to this connector.

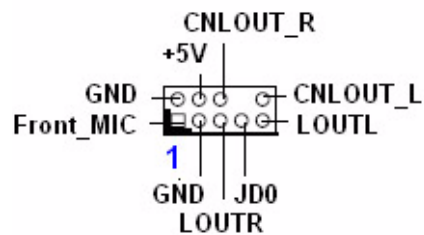
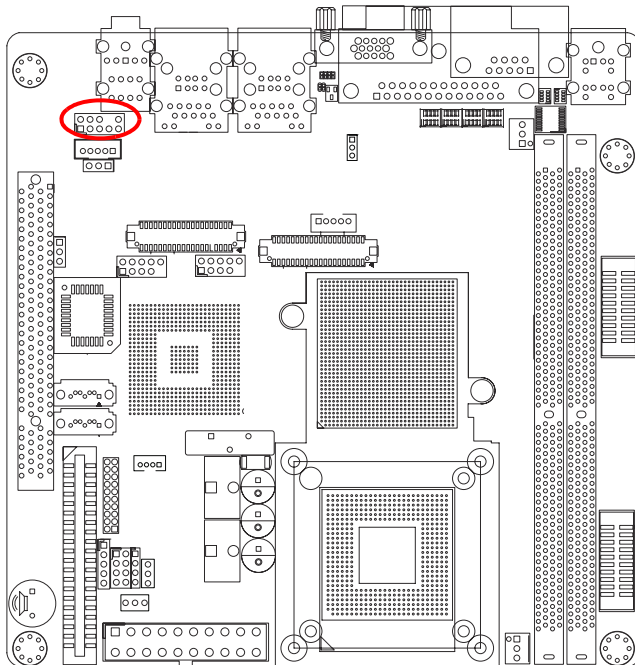

**Note!** For motherboards with the optional HD Audio feature, we recommend that you connect a high-definition front panel audio module to this connector to avail of the motherboard's high definition audio capability.



## 1.14.7 Front Panel Connector (JFP1/JFP2/JFP3)

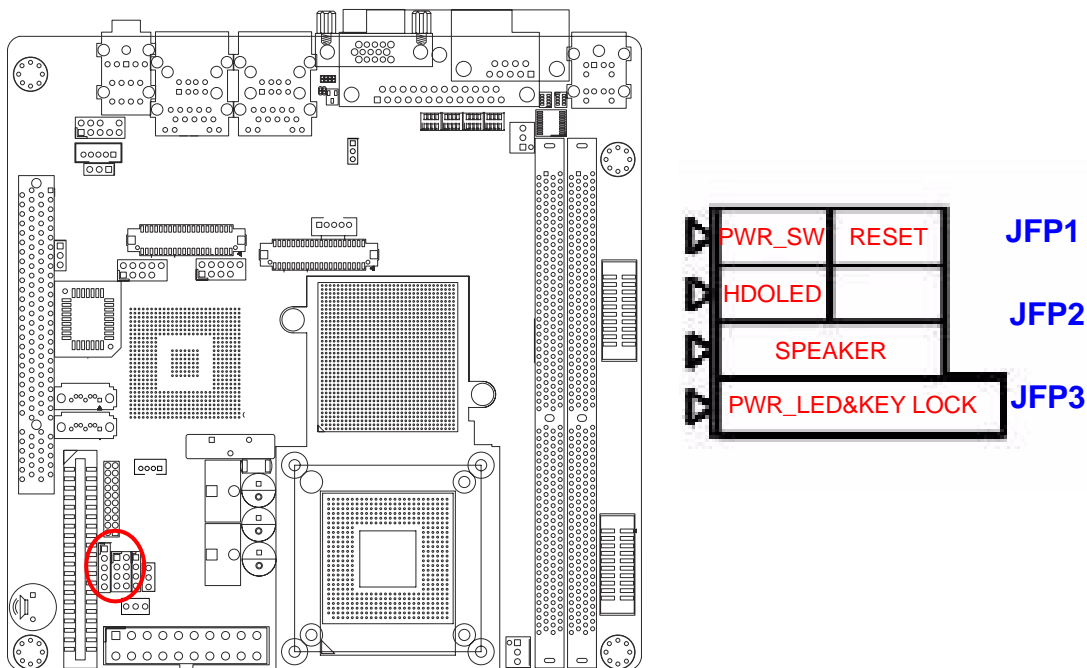

There are several external switches to monitor and control the AIMB-252.

### 1.14.8 ATX soft power switch (JFP1 / PWR\_SW)

If your computer case is equipped with an ATX power supply, you should connect the power on/off button on your computer case to (JFP1/PWR\_SW). This connection enables you to turn your computer on and off.

### 1.14.9 Reset (JFP1 / RESET)

Many computer cases offer the convenience of a reset button. Connect the wire for the reset button.

### 1.14.10 HDD LED (JFP2 / HDDLED)

You can connect an LED to connector (JFP2/HDDLED) to indicate when the HDD is active.

### 1.14.11 External speaker (JFP2 / SPEAKER)

(JFP2 / SPEAKER) is a 4-pin connector for an external speaker. If there is no external speaker, the AIMB-252 provides an onboard buzzer as an alternative. To enable the buzzer, set pins 3-4 as closed.

### 1.14.12 Power LED and keyboard lock connector (JFP3 / PWR\_LED&KEY LOCK)

(JFP3 / PWR\_LED&KEY LOCK) is a 5-pin connector for the power on LED and Key Lock function. Refer to Appendix B for detailed information on the pin assignments. The Power LED cable should be connected to pin 1-3. The key lock button cable should be connected to pin 4-5.

There are 3 modes for the power supply connection. The first is “ATX power mode”, system is on/off by a tentative power button. The second is “AT Power Mode”, system is on/off by the switch of the Power supply. The third is another “AT Power Mode” which is using the front panel power switch. The power LED status is indicated as following table:

**Table 1.10: ATX power supply LED status (No support for AT power)**

Power Mode	LED (ATX Power Mode) (On/Off by tentative button)	LED (AT Power Mode) (On/Off by switching power supply)	LED (AT Power Mode) (On/Off by front panel switch)
PS0N1 (On Back plane) Jumper Setting	2-3 pin closed	1-2 pin closed	Connect 1-2 pin cable with switch
System On	On	On	On
System Status	Fast flashes	Fast flashes	Fast flashes
System Off	Slow flashes	Off	Off

### 1.14.13 USB 2.0 Connector (USB56, USB78)

These connectors are for USB 2.0 ports. Connect the USB/GAME module cable to any of these connectors, then install the module to a slot opening at the back of the system chassis. These USB connectors comply with USB 2.0 specification that supports up to 480 Mbps connection speed.

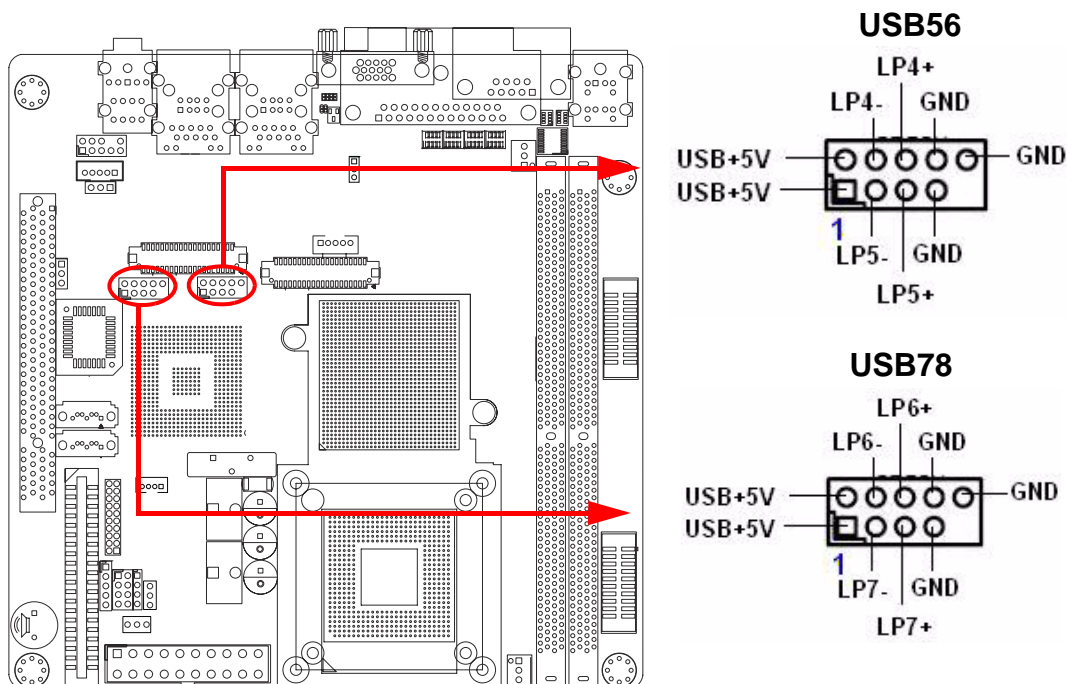

**Caution!** Never connect a 1394 cable to the USB connectors. Doing so will damage the motherboard!



**Note!** The USB module is purchased separately.



### 1.14.14 ATX Power Connector (EATXPWR1)

This connector is for an ATX Micro-Fit power supply. The plugs from the power supply are designed to fit these connectors in only one orientation. Find the proper orientation and push down firmly until the connectors completely fit.

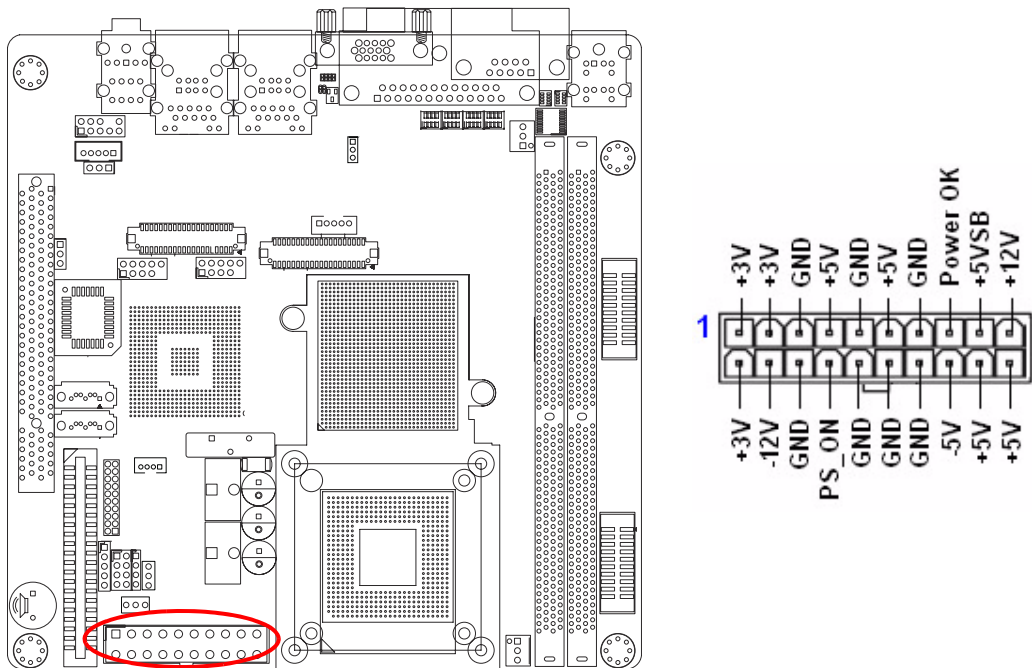

#### Important notes on the Motherboard Power Requirements

- Note!**
- Make sure that your ATX 12 V power supply can provide 6 A on the +12 V lead and at least 1A on the +5-volt standby lead (+5 VSB). The minimum recommended wattage is 180 W for a fully configured system. The system can become unstable and might experience difficulty powering up if the power supply is inadequate.
  - You must install a PSU with a higher power rating if you intend to install additional devices.

### 1.14.15 LCD Inverter Connector (INV1) & LVDS (INV2)

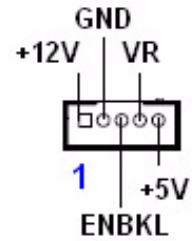
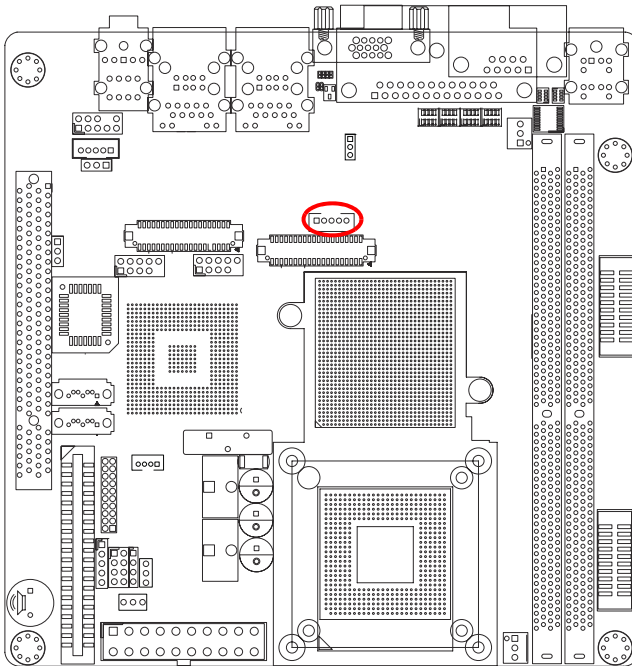

**Note!** ■ Signal Description



**Signal**

VR

ENBKL

**Signal Description**

$V_{adj}=0.75 V$

(Recommended:  $4.7K \Omega$  ,  $> 1/16 W$ )

LCD backlight ON/OFF control signal

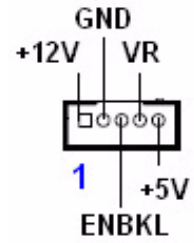
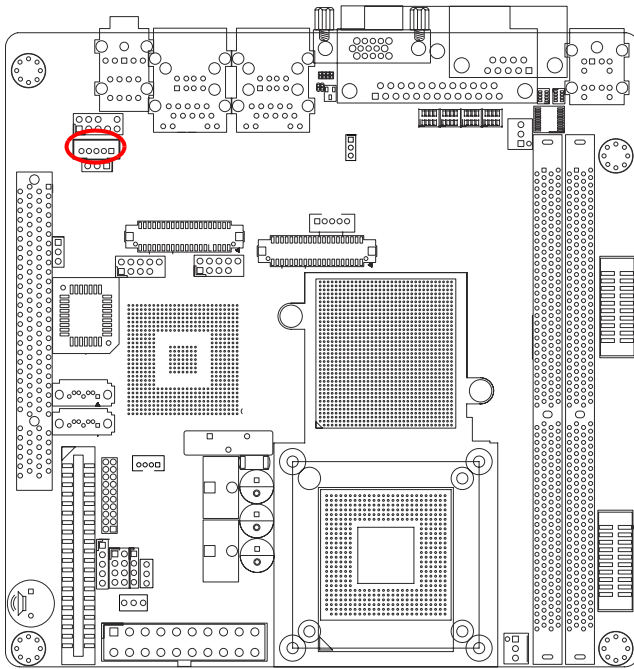

**Note!** ■ Signal Description



**Signal**

VR

**Signal Description**

$V_{adj}=0.75\text{ V} \sim 4.25\text{ V}$

(Recommended:  $4.7\text{K } \Omega$  ,  $> 1/16\text{ W}$ )

ENBKL

LCD backlight ON/OFF control signal



### 1.14.16 LVDS Connector (LVDS1)

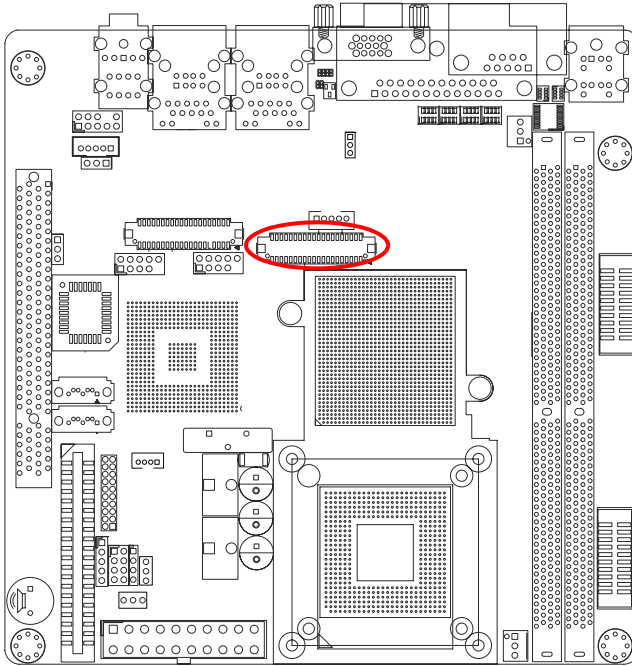

**1**

VDDSAFE_1	<input type="checkbox"/>	<input type="radio"/>	VDDSAFE_2
GND_1	<input type="radio"/>	<input type="radio"/>	GND_7
VDDSAFE_3	<input type="radio"/>	<input type="radio"/>	VDDSAFE_4
OD0-	<input type="radio"/>	<input type="radio"/>	ED0-
OD0+	<input type="radio"/>	<input type="radio"/>	ED0+
GND_2	<input type="radio"/>	<input type="radio"/>	GND_8
OD1-	<input type="radio"/>	<input type="radio"/>	ED1-
OD1+	<input type="radio"/>	<input type="radio"/>	ED1+
GND_3	<input type="radio"/>	<input type="radio"/>	GND_9
OD2-	<input type="radio"/>	<input type="radio"/>	ED2-
OD2+	<input type="radio"/>	<input type="radio"/>	ED2+
GND_4	<input type="radio"/>	<input type="radio"/>	GND_10
OCK-	<input type="radio"/>	<input type="radio"/>	ECK-
OCK+	<input type="radio"/>	<input type="radio"/>	ECK+
GND_5	<input type="radio"/>	<input type="radio"/>	GND_11
DDC_CLK	<input type="radio"/>	<input type="radio"/>	DDC_DAT
GND_6	<input type="radio"/>	<input type="radio"/>	GND_12
NC	<input type="radio"/>	<input type="radio"/>	NC
NC	<input type="radio"/>	<input type="radio"/>	NC
HPLG	<input type="radio"/>	<input type="radio"/>	VCON

### 1.14.17 LVDS Connector (LVDS2)

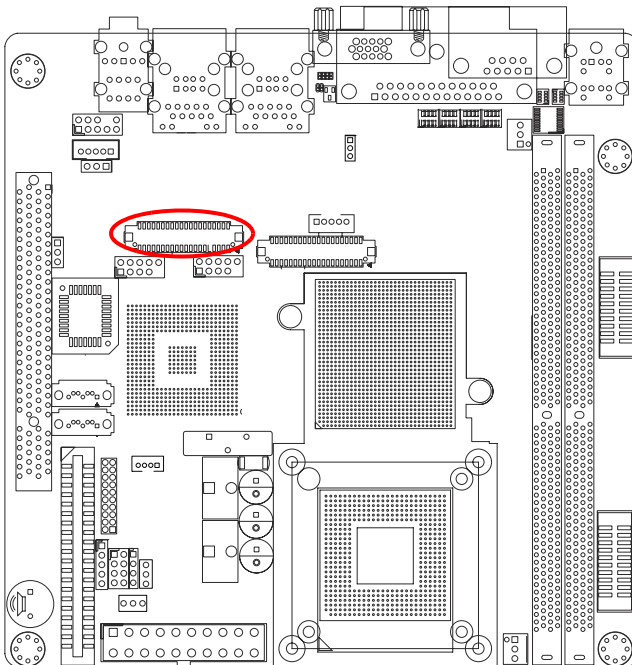

**1**

VDDSAFE_1	<input type="checkbox"/>	<input type="radio"/>	VDDSAFE_2
GND_1	<input type="radio"/>	<input type="radio"/>	GND_7
VDDSAFE_3	<input type="radio"/>	<input type="radio"/>	VDDSAFE_4
OD0-	<input type="radio"/>	<input type="radio"/>	ED0-
OD0+	<input type="radio"/>	<input type="radio"/>	ED0+
GND_2	<input type="radio"/>	<input type="radio"/>	GND_8
OD1-	<input type="radio"/>	<input type="radio"/>	ED1-
OD1+	<input type="radio"/>	<input type="radio"/>	ED1+
GND_3	<input type="radio"/>	<input type="radio"/>	GND_9
OD2-	<input type="radio"/>	<input type="radio"/>	ED2-
OD2+	<input type="radio"/>	<input type="radio"/>	ED2+
GND_4	<input type="radio"/>	<input type="radio"/>	GND_10
OCK-	<input type="radio"/>	<input type="radio"/>	ECK-
OCK+	<input type="radio"/>	<input type="radio"/>	ECK+
GND_5	<input type="radio"/>	<input type="radio"/>	GND_11
DDC_CLK	<input type="radio"/>	<input type="radio"/>	DDC_DAT
GND_6	<input type="radio"/>	<input type="radio"/>	GND_12
OD3-	<input type="radio"/>	<input type="radio"/>	ED3-
OD3+	<input type="radio"/>	<input type="radio"/>	ED3+
HPLG	<input type="radio"/>	<input type="radio"/>	VCON

## 1.14.18 Digital I/O Connector (GPIO1)

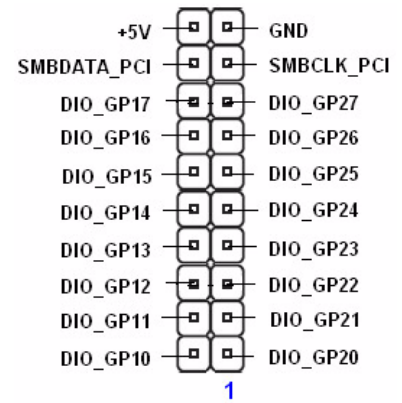
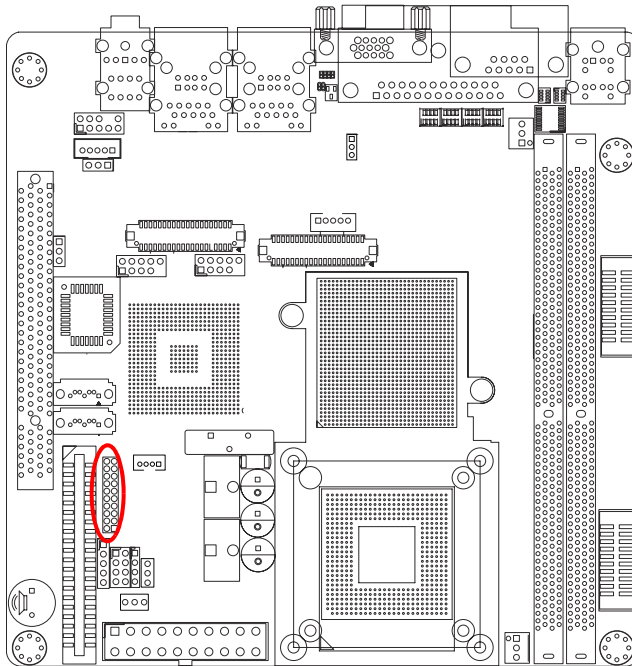

## 1.14.19 Serial ATA Connector 1 & 2 (SATA1, SATA2)

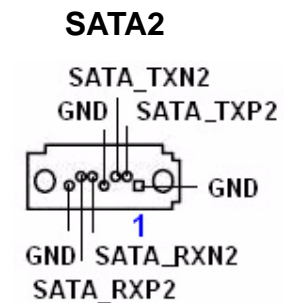
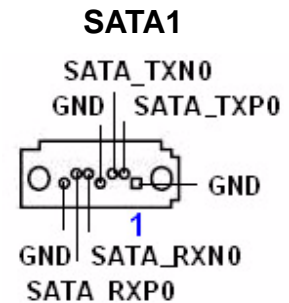
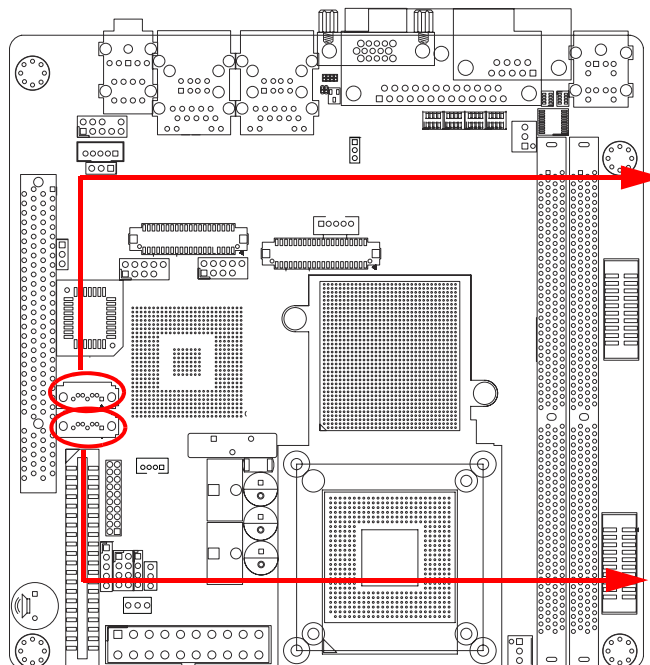

- Note!**
- Install the Windows® 2000 Service Pack 4 or the Windows® XP Service Pack1 before using Serial ATA.
  - When using the connectors in Standard IDE mode, connect the primary (boot) hard disk drive to the SATA1 connector.



# Chapter 2

BIOS Operation

## 2.1 BIOS Introduction

Advantech provide full-featured AwardBIOS 6.0 and delivers the superior performance, compatibility and functionality that manufactures of Industry PC and Embedded boards, it's many options and extensions let you customize your products to a wide range of designs and target markets.

The modular, adaptable AwardBIOS 6.0 supports the broadest range of third-party peripherals and all popular chipsets, plus Intel, AMD, nVidia, VIA, and compatible CPUs from 386 through Pentium and AMD Geode, K7 and K8 (including multiple processor platforms), and VIA Eden C3 and C7 CPU.

You can use Advantech's utilities to select and install features to suit your designs for customers need.

## 2.2 BIOS Setup

The AIMB-252 Series system has build-in AwardBIOS with a CMOS SETUP utility which allows user to configure required settings or to activate certain system features.

The CMOS SETUP saves the configuration in the CMOS RAM of the motherboard. When the power is turned off, the battery on the board supplies the necessary power to the CMOS RAM.

When the power is turned on, press the <Del> button during the BIOS POST (Power-On Self Test) will take you to the CMOS SETUP screen.

---

### CONTROL KEYS

---

< ↑ >< ↓ >< ← >< → >	Move to select item
<Enter>	Select Item
<Esc>	Main Menu - Quit and not save changes into CMOS Sub Menu - Exit current page and return to Main Menu
<Page Up/+>	Increase the numeric value or make changes
<Page Down/->	Decrease the numeric value or make changes
<F1>	General help, for Setup Sub Menu
<F2>	Item Help
<F5>	Load Previous Values
<F7>	Load Optimized Default
<F10>	Save all CMOS changes

---

## 2.2.1 Main Menu

Press <Del> to enter AwardBIOS CMOS Setup Utility, the Main Menu will appear on the screen. Use arrow keys to select among the items and press <Enter> to accept or enter the sub-menu.

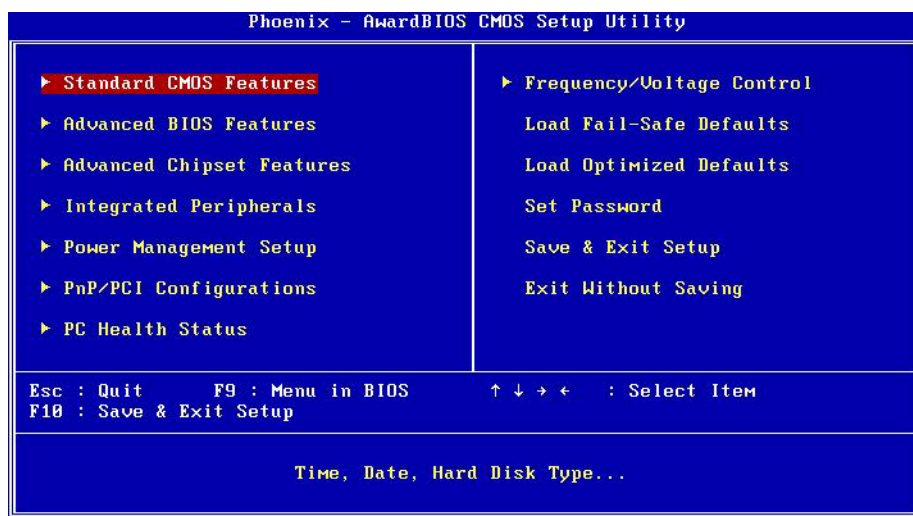

- **Standard CMOS Features**  
This setup page includes all the items in standard compatible BIOS.
- **Advanced BIOS Features**  
This setup page includes all the items of Award BIOS enhanced features.
- **Advanced Chipset Features**  
This setup page includes all the items of Chipset configuration features.
- **Integrated Peripherals**  
This setup page includes all onboard peripheral devices.
- **Power Management Setup**  
This setup page includes all the items of Power Management features.
- **PnP/PCI Configurations**  
This setup page includes PnP OS and PCI device configuration.
- **PC Health Status**  
This setup page includes the system auto detect CPU and system temperature, voltage, fan speed.
- **Frequency/Voltage Control**  
This setup page includes CPU host clock control, frequency ratio and voltage.
- **Load Optimized Defaults**  
This setup page includes Load system optimized value, and the system would be in best performance configuration.
- **Set Password**  
Establish, change or disable password.
- **Save & Exit Setup**  
Save CMOS value settings to CMOS and exit BIOS setup.
- **Exit Without Saving**  
Abandon all CMOS value changes and exit BIOS setup.

## 2.2.2 Standard CMOS Features

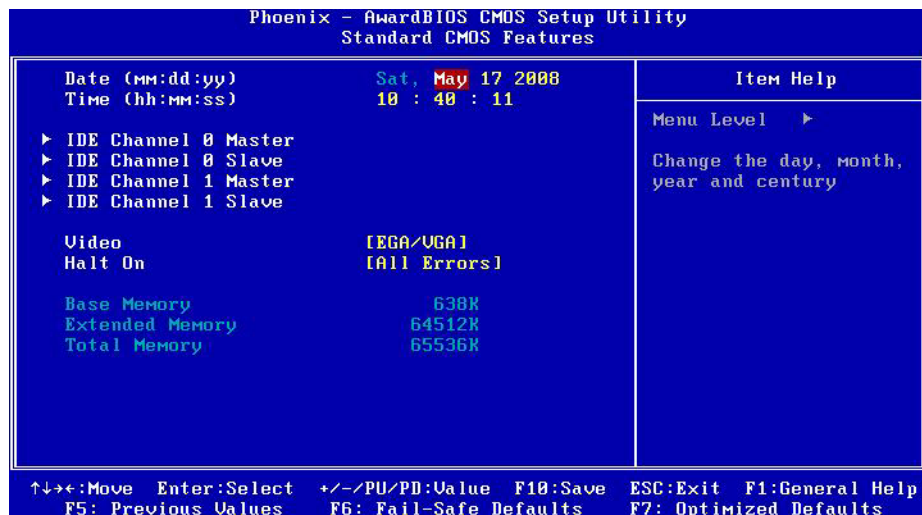

- **Date**  
The date format is <week>, <month>, <day>, <year>.
 

Week	From Sun to Sat, determined and display by BIOS only
Month	From Jan to Dec.
Day	From 1 to 31
Year	From 1999 through 2098
- **Time**  
The times format in <hour> <minute> <second>, base on the 24-hour time
- **IDE Channel 0/1, Master/Slave**  
IDE HDD Auto-Detection Press "Enter" for automatic device detection.
- **Halt on**  
The item determines whether the computer will stop if an error is detected during power up.
 

No Errors	The system boot will not stop for any error
All Errors	Whenever the BIOS detects a non-fatal error the system will be stopped.
All, But Keyboard	The system boot will not stop for a keyboard error; it will stop for all other errors. (Default value)
All, But Diskette	The system boot will not stop for a disk error; it will stop for all other errors.
All, But Disk/Key	The system boot will not stop for a keyboard or disk error; it will stop for al other errors.
- **Base Memory**  
The POST of the BIOS will determine the amount of base (or conventional) memory installed in the system.
- **Extended Memory**  
The POST of the BIOS will determine the amount of extended memory (above 1MB in CPU's memory address map) installed in the system.
- **Total Memory**  
This item displays the total system memory size.

## 2.2.3 Advanced BIOS Features

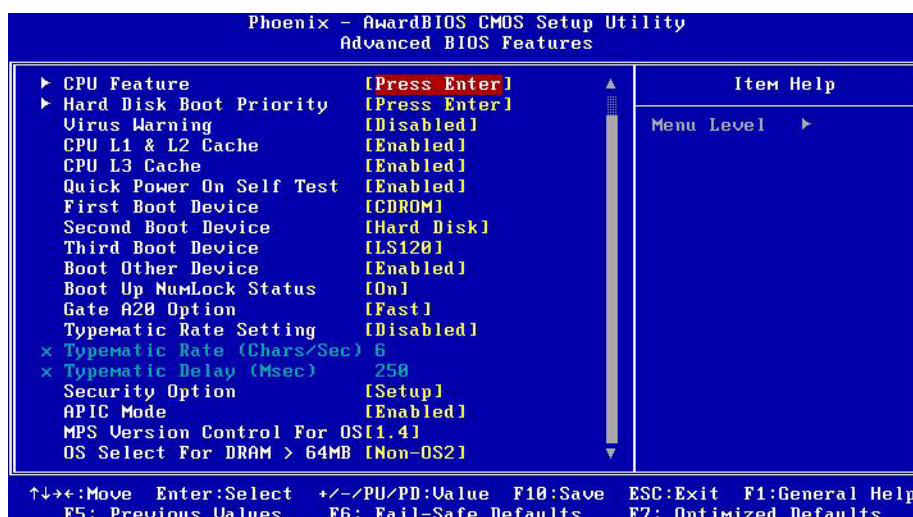

- **CPU Feature**

This item allows user to adjust CPU features, CPU ratio, VID and Thermal and special feature like XD flag.

- **Hard Disk Boot Priority**

This item allows user to select boot sequence for system device HDD, SCSI, RAID.

- **Virus Warning [Disabled]**

Enables or disables the virus warning.

- **CPU L1 & L2 Cache [Enabled]**

This item allows user to enable CPU L1 and L2 cache.

- **Quick Power On Self Test [Enabled]**

This field speeds up the Power-On Self Test (POST) routine by skipping retesting a second, third and fourth time. Setup setting default is enabled.

- **First / Second / Third / Other Boot Drive**

Hard Disk	Select boot device priority by Hard Disk.
CDROM	Select boot device priority by CDROM.
USB-FDD	Select boot device priority by USB-FDD.
USB-ZIP	Select boot device priority by USB-ZIP.
USB-CDROM	Select boot device priority by USB-CDROM.
LAN	Select boot device priority by LAN.
Disabled	Disable this boot function.

- **Swap Floppy Drive[Disabled]**

This item enables users to swap floppy "A" and "B" identified without change hardware cable connection.

- **Boot Up Floppy Seek [Disabled]**

When enabled, the BIOS will seek the floppy "A" drive one time

- **Boot Up NumLock Status [Enabled]**

This item enables users to activate the Number Lock function upon system boot

- **Gate A20 Option [Fast]**

This item enables users to switch A20 control by port 92 or not.

- **Typematic Rate Setting**

This item enables users to set the two typematic controls items.

This field controls the speed at

- Typematic Rate (Chars/Sec)

This item controls the speed at system registers repeated keystrokes.

Eight settings are 6, 8, 10, 12, 15, 20, 24 and 30.

- Typematic Delay (Msec)

This item sets the time interval for displaying the first and second characters.

Four delay rate options are 250, 500, 750 and 1000.

- **Security Option [Setup]**

System	System can not boot and can not access to Setup page if the correct password is not entered at the prompt.
Setup	System will boot, but access to Setup if the correct password is not entered at the prompt. (Default value)

- **APIC Mode [Enabled]**

This item allows user to enabled of disabled “Advanced Programmable Interrupt Controller”. APIC is implemented in the motherboard and must be supported by the operating system, and it extends the number of IRQ's available.

## 2.2.4 Advanced Chipset Features

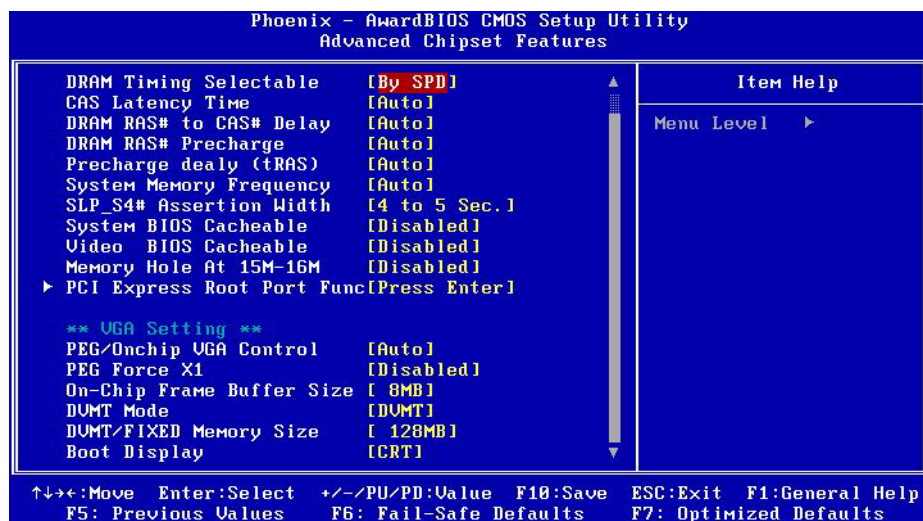

**Note!**  This “Advanced Chipset Features” option controls the configuration of the board’s chipset, this page is developed by Chipset independent, for control chipset register setting and fine tune system performance. It is strongly recommended only technical users make changes to the default settings.

- **DRAM Timing Selectable [By SPD]**

This item enables users to set the optimal timings for items 2 through 5, system default setting of “By SPD” to follow the SPD information and ensure the system running in stable and optimal performance.

- **CAS Latency Time [Auto]**

This item enables users to set the timing delay in clock cycles before SDRAM start a read command after receiving it.

- **DRAM RAS# to CAS# Delay [Auto]**  
 This item enables users to set the timing of the transition from RAS (row address strobe) to CAS (column address strobe) as both rows and column are separately addressed shortly after DRAM is refreshed.
- **DRAM RAS# Precharge [Auto]**  
 This item enables users to set the DRAM RAS# precharge timing, system default is setting to “Auto” to reference the data from SPD ROM.
- **Prechage delay (tRAS) [Auto]**  
 This item allows user to adjust memory precharge time.
- **System Memory Frequency [Auto]**  
 This item allows user to adjust memory frequency to improvement performance.  
     SLP\_S4# Assertion Width {1 to 5 sec}
- **System BIOS Cacheable [Enabled]**  
 This item allows the system BIOS to be cached to allow faster execution and better performance.
- **Video BIOS Cacheable [Disabled]**  
 This item allows the video BIOS to be cached to allow faster execution and better performance.
- **Memory Hole At 15 M-16 M [Disabled]**  
 This item reserves 15 MB-16 MB memory address space to ISA expansion cards that specifically require the setting. Memory from 1 5MB-16 MB will be unavailable to the system because of the expansion cards can only access memory at this area.
- **PCI Express Root Port Function [Press Enter]**  
 This item allows the user to adjust PCIE port on,off or auto.
- **VGA setting**  
 PEG/Onchip VGA Control  
 Use this field to select PEG or Onchip VGA. The default is AUTO.
- **On-Chip Frame Buffer Size [8 MB]**  
 This item allows the user to adjust on-chip graphics of memory buffer.
- **DVMT Mode [DVMT]**  
 This item allows the user to adjust Intel's Dynamic Video Memory Technology (DVMT).Bios provide three option to choose (DVMT, FIXED and Both).
- **DVMT/FIXED Memory Size [128 MB]**  
 This item allows the user to adjust DVMT/FIXED graphics memory size.
- **Boot Display [Auto]**  
 This item allows the user to decide that display mode.
- **LVDS Panel Type [1024 \* 768]**  
 This item allows the user to adjust panel resolution.



## 2.2.5 Integrated Peripherals

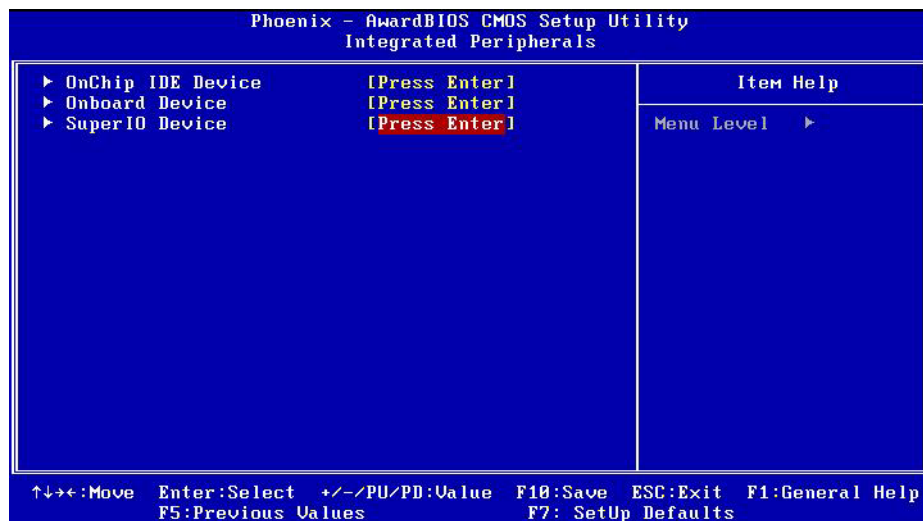

**Note!** This “Integrated Peripherals” option controls the configuration of the board’s chipset, includes IDE, ATA, SATA, USB, AC97, MC97 and Super IO and Sensor devices, this page is developed by Chipset independent.



- **OnChip IDE Device**  
This item enables users to set the OnChip IDE device status, includes enable IDE devices and setting PIO and DMA access mode, and some of new chipset also support for SATA device (Serial-ATA)
- **Onboard Device**  
This item enables users to set the Onboard device status, includes enable USB, AC97, MC97 and LAN devices.
- **Super IO Device**  
This item enables users to set the Super IO device status, includes enable Floppy, COM, LPT, IR and control GPIO and Power fail status.

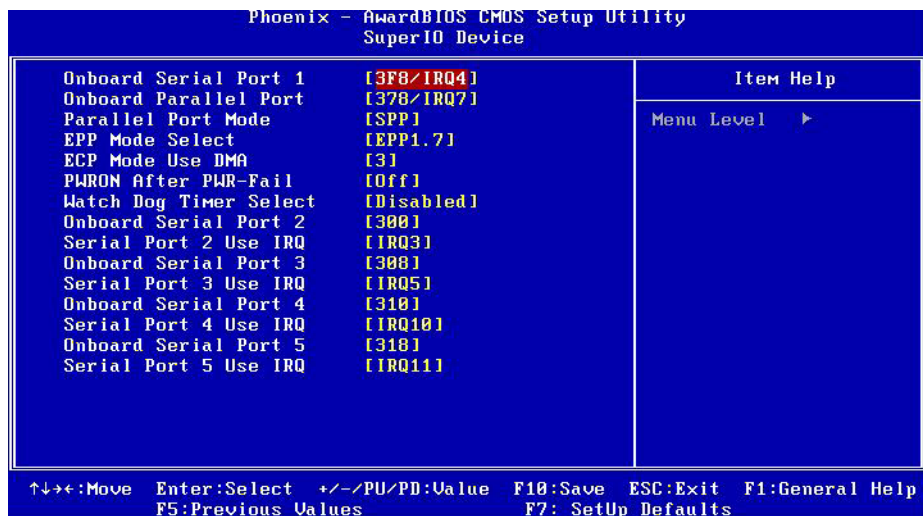



- **Onboard Serial port 1 [3F8 / IRQ4]**  
This item allows user to adjust serial port 1 of address and IRQ.
- **Onboard Parallel Port [378/IRQ7]**  
This item allows user to adjust parallel port of address and irq.
- **Parallel Port Mode [ECP+EPP]**  
This item allows user to adjust parallel port mode.
- **EPP Mode Select [EPP1.9]**  
This field allows you to select EPP port type 1.7 or 1.9. The choices are “EPP1.9” and “EPP1.7”.
- **ECP Mode Use DMA [3]**  
This item allows user to adjust ECP DMA resource.
- **Power on after power fail**  
Use this to set up the system after power failure. The .Off. setting keeps the system powered off after power failure. The .On. setting boots up the system after failure.
- **Watch Dog Timer Select [Disabled]**  
When disabled, the Watchdog Timer will be disabled. It will not monitor the time taken for each task performed by the operating system.  
When set to any time period from 10 Sec to 4 Min, the Watchdog Timer will be enabled after that time period passes, every time the system boots up
- **Onboard Serial Port 3 [4F8]**  
This item allows user to adjust serial port 3 of address.
- **Serial Port 3 Use IRQ [IRQ5]**  
This item allows user to adjust serial port 3 of IRQ.
- **Onboard Serial Port 4 [4E8]**  
This item allows user to adjust serial port 4 of address.
- **Serial Port 4 Use IRQ [IRQ10]**  
This item allows user to adjust serial port 4 of IRQ.
- **Onboard Serial Port 5 [4F0]**  
This item allows user to adjust serial port 5 of address.
- **Serial Port 5 Use IRQ [IRQ11]**  
This item allows user to adjust serial port 5 of IRQ.

## 2.2.6 Power Management Setup

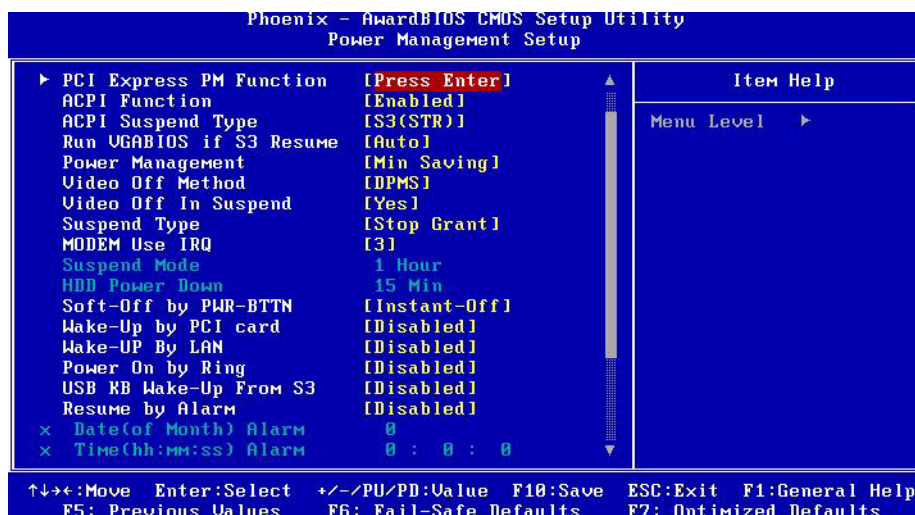

**Note!** This “Power management Setup” option configure system to most effectively saving energy while operating in a manner consistent with your computer use style.



- **PCI Express PM Function**  
This allow you to control Power On by onboard LAN chip feature.
- **ACPI Function [Enabled]**  
This item defines the ACPI (Advanced Configuration and Power Management) feature that makes hardware status information available to the operating system, and communicate PC and system devices for improving the power management.
- **ACPI Suspend Type [S1 (POS)]**  
This item allows user to select sleep state when suspend.
 

S1(POS)	The suspend mode is equivalent to a software power down;
S3(STR)	The system shuts down with the exception of a refresh current to the system memory.
- **Run VGA BIOS if S3 Resume [Auto]**  
This item allows system to reinitialize VGA BIOS after system resume from ACPI S3 mode.
- **Power Management [User Define]**  
This item allows user to select system power saving mode.
 

Min Saving	Minimum power management. Suspend Mode=1 hr.
Max Saving	Maximum power management. Suspend Mode=1 min.
User Define	Allows user to set each mode individually. Suspend Mode= Disabled or 1 min ~1 hr.

- **Video Off Method [DPMS]**  
This item allows user to determine the manner in which the monitor is blanked.
 

V/H SYNC+Blank	This option will cause system to turn off vertical and horizontal synchronization ports and write blanks to the video buffer.
Blank Screen	This option only writes blanks to the video buffer.
DPMS	Initial display power management signaling.
- **Video Off In Suspend [Yes]**  
This item allows user to turn off Video during system enter suspend mode.
- **Suspend Type [Stop Grant]**  
This item allows user to determine the suspend type.
- **Modem use IRQ [3]**  
This item allows user to determine the IRQ which the MODEM can use.
- **Suspend Mode [Disabled]**  
This item allows user to determine the time of system inactivity, all devices except the CPU will be shut off.
- **HDD Power Down Mode [Disabled]**  
This item allows user to determine the time of system inactivity, the hard disk drive will be powered down.
- **Soft-Off by PWR-BTTN [Instant-Off]**  
This item allows user to define function of power button.
 

Instant-Off	Press power button then Power off instantly.
Delay 4 Sec	Press power button 4 sec. to Power off.
- **Wake up by PCI card**  
This item allows user to Wake up the system by PCI card. The choices are "Enabled" and "Disabled".
- **Wake up by LAN [Enabled]**  
This item allows user to Wake up the system by LAN. The choices are "Enabled" and "Disabled".
- **Wake up by ring [Enabled]**  
This item allows you to wake up the system via COM port from the remote host. The choices: "Enabled", "Disabled".
- **USB KB Wake\_Up From S3 [Disabled]**  
This item allows user to set USB keyboard wake up system from S3 Enable or Disable.
- **Resume by Alarm [Disabled]**  
The choices are "Enabled" and "Disabled". Fields that follow below indicate date of current month and time of alarm settings, if enabled.
- **Primary IDE 0 (1) and Secondary IDE 0 (1) [Disabled]**  
When Enabled, the system will resume from suspend mode if Primary IDE 0 (1) or Secondary IDE 0 (1) becomes active. The choices are "Enabled" and "Disabled".
- **FDD, COM, LPT PORT [Disabled]**  
When Enabled, the system will resume from suspend mode if the FDD, interface, COM port, or LPT port is active. The choices are "Enabled" and "Disabled".
- **PCI PIRQ [A-D]# [Disabled]**  
When Enabled, the system resumes from suspend mode if an interrupt occurs. The choices are "Enabled" and "Disabled".

## 2.2.7 PnP/PCI Configurations

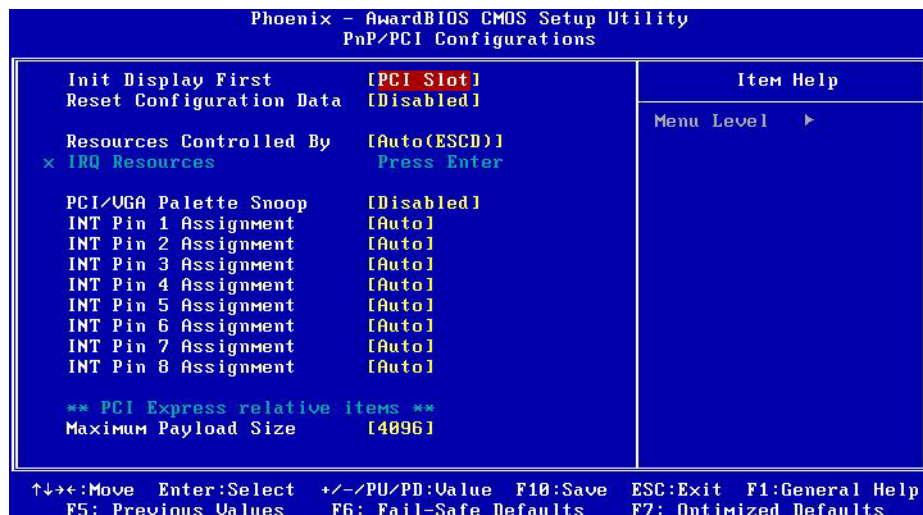

- **Init Display first [PCI slot]**  
Choose the first display interface to initiate while booting. The choice is "PCI Slot" or "Onboard."
- **Reset Configuration Data [Disabled]**  
The default is Disabled. Select Enabled to reset Extended System Configuration Data (ESCD) if you have installed a new add-on card, and system configuration is in such a state that the OS cannot boot.
- **Resources Controlled By [Auto(ESCD)]**  
The commands here are "Auto(ESCD)" or "Manual". Choosing "Manual" requires you to choose resources from the following sub-menu. "Auto(ESCD)" automatically configures all of the boot and Plug and Play devices, but you must be using Windows 95 or above.
- **PCI / VGA Palette Snoop [Disabled]**  
This is set to "Disabled" by default.
- **Maximum Payload Size [4096]**  
This allows you to set the maximum TLP payload size for PCI Express devices. The options are [128 bytes], [256 bytes], [512 bytes], [1024 bytes], [2048 bytes], and [4096 bytes].

## 2.2.8 PC Health Status

Phoenix - AwardBIOS CMOS Setup Utility		Item Help
PC Health Status		Menu Level ▶
CPU Warning Temperature	[Disabled]	
Current System1 Temp.	34°C/ 93°F	
Current CPU Temp.	46°C/114°F	
Current System2 Temp.	24°C/ 75°F	
Current System1 Speed.	0 RPM	
Current CPUFAN Speed.	0 RPM	
Current System2 Speed.	0 RPM	
+12V	11.77 V	
+5 V	5.04 V	
+3.3V	3.28 V	
VCORE	0.99 V	
VBAT(V)	3.28 V	
5USB(V)	4.92 V	
Shutdown Temperature	[Disabled]	

- **CPU Warning Temperature**  
This item will prevent the CPU from overheating. The choices are “Disabled”, “60C/140F”, “63C/145F”, “66C/151F”, “70C/158F”, “75C/167F”, “80C/176F”, “85C/185F”, “90C/194F”, and “95C/205F”.
- **Current System Temperature**  
This shows you the current temperature of system.
- **Current CPU Temperature**  
This shows the current CPU temperature.
- **VCORE and Other Voltages**  
This shows the voltage of VCORE, +1.5 V, +3.3, +5 V, VBAT (V), and 5 VSB (V).
- **Shutdown Temperature**  
The system will shut down automatically when the CPU temperature is over the selected setting. This function can prevent CPU damage caused by overheating.

## 2.2.9 Frequency/voltage Control

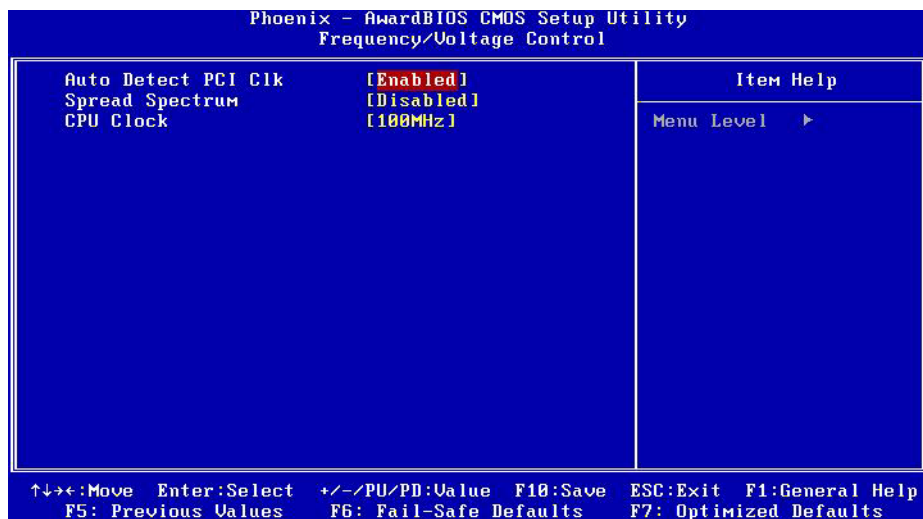

- **Auto Detect PCI Clk [Enabled]**  
When enabled, the BIOS will monitor PCI slots and turn off clock signals to all unoccupied and inactive slots.  
When disabled, the BIOS will not monitor PCI slots. All clock signals will remain active even to unoccupied or inactive slots.
- **Spread Spectrum [Disabled]**  
This item enables users to set the spread spectrum modulation.
- **CPU Clock**  
It shows CPU Clock frequency

## 2.2.10 Load Setup Defaults

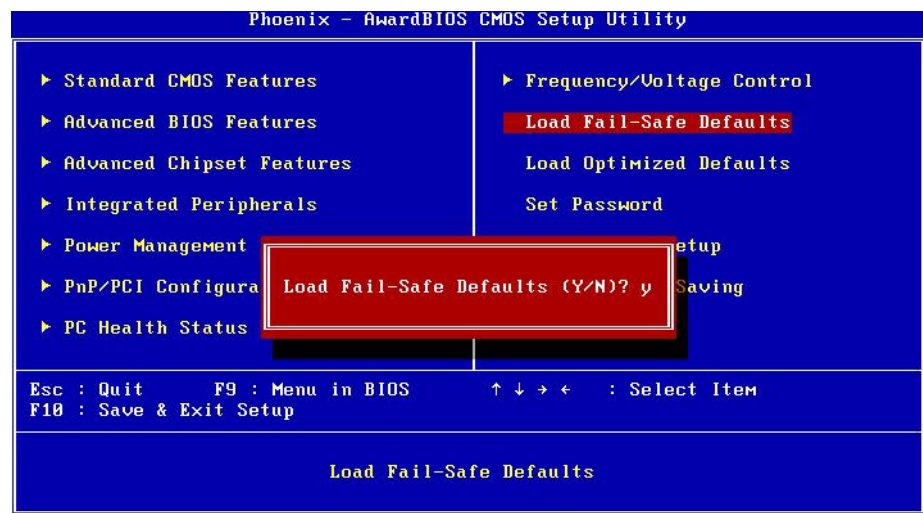

**Note!** *Load Setup Defaults loads the default system values directly from ROM. If the stored record created by the Setup program should ever become corrupted (and therefore unusable).*



*These defaults will load automatically when you turn the AIMB-252 Series system on.*



## 2.2.11 Set Password

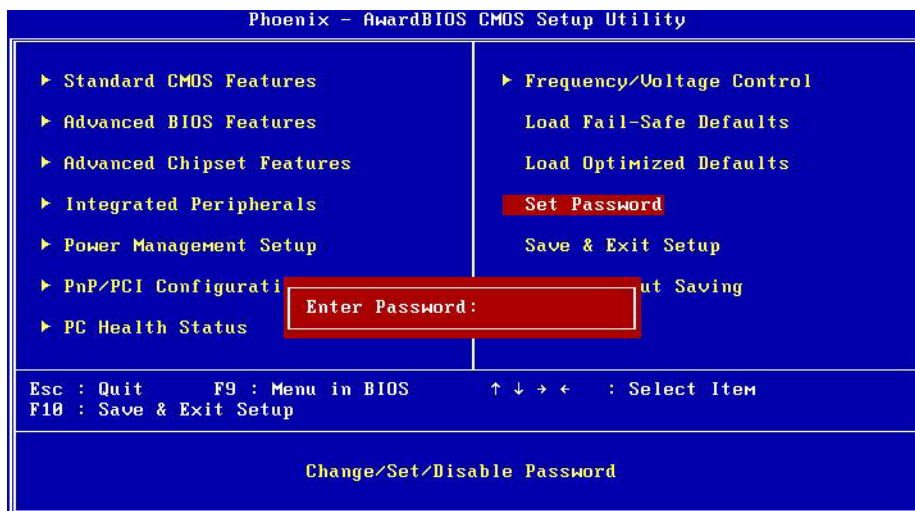

**Note!**  To enable this feature, you should first go to the Advanced BIOS Features menu, choose the Security Option, and select either Setup or System, depending on which aspect you want password protected. Setup requires a password only to enter Setup. System requires the password either to enter Setup or to boot the system. A password may be at most 8 characters long.

### To Establish Password

1. Choose the Set Password option from the CMOS Setup Utility main menu and press <Enter>.
2. When you see “Enter Password”, enter the desired password and press <Enter>.
3. At the “Confirm Password” prompt, retype the desired password, then press <Enter>.
4. Select Save to CMOS and EXIT, type <Y>, then <Enter>.

### To Change Password

1. Choose the Set Password option from the CMOS Setup Utility main menu and press <Enter>.
2. When you see “Enter Password”, enter the existing password and press <Enter>.
3. You will see “Confirm Password”. Type it again, and press <Enter>.
4. Select Set Password again, and at the “Enter Password” prompt, enter the new password and press <Enter>.
5. At the “Confirm Password” prompt, retype the new password, and press <Enter>.
6. Select Save to CMOS and EXIT, type <Y>, then <Enter>.

---

### **To Disable Password**

1. Choose the Set Password option from the CMOS Setup Utility main menu and press <Enter>.
2. When you see “Enter Password”, enter the existing password and press <Enter>.
3. You will see “Confirm Password”. Type it again, and press <Enter>.
4. Select Set Password again, and at the “Enter Password” prompt, please don't enter anything; just press <Enter>.
5. At the “Confirm Password” prompt, again, don't type in anything; just press <Enter>.
6. Select Save to CMOS and EXIT, type <Y>, then <Enter>.



## 2.2.12 Save & Exit Setup

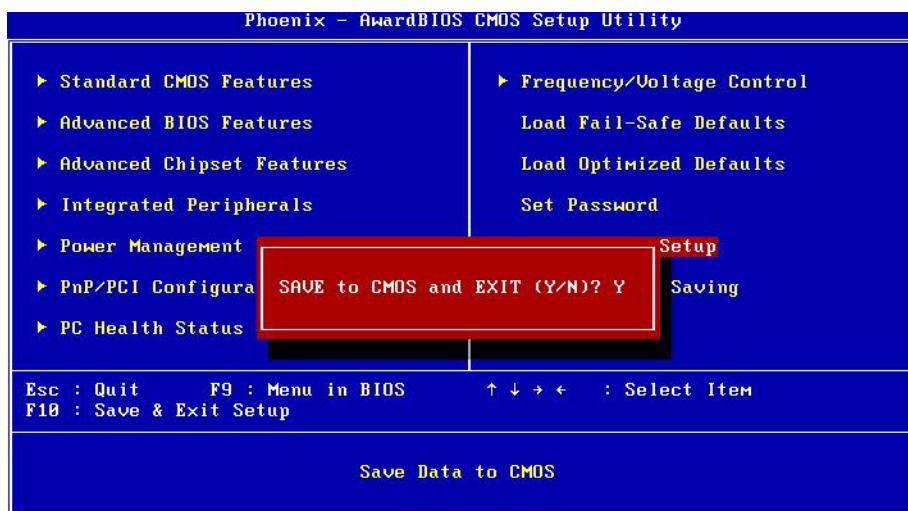

**Note!** Type "Y" will quit the BIOS Setup Utility and save user setup value to CMOS.



Type "N" will return to BIOS Setup Utility.

## 2.2.13 Quit Without Saving

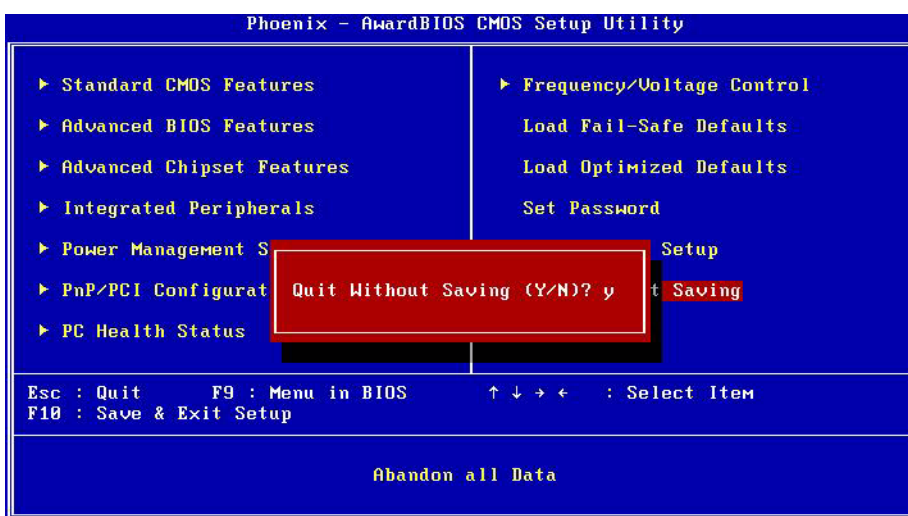

**Note!** Type "Y" will quit the BIOS Setup Utility without saving to CMOS.



Type "N" will return to BIOS Setup Utility.



# Chapter 3

Chipset Software  
Install Utility

## 3.1 Before you Begin

To facilitate the installation of the enhanced display device drivers and utility software, you should read the instructions in this chapter carefully before you attempt installation. The device drivers for the AIMB-252 board are located on the software installation CD. The auto-run function of the driver CD will guide and link you to the utilities and device drivers under a Windows system. The Intel® Chipset Software Installation Utility is not required on any systems running Windows NT 4.0. Updates are provided via Service Packs from Microsoft\*.

**Note!** *The files on the software installation CD are compressed. Do not attempt to install the drivers by copying the files manually. You must use the supplied SETUP program to install the drivers*



Before you begin, it is important to note that most display drivers need to have the relevant software application already installed in the system prior to installing the enhanced display drivers. In addition, many of the installation procedures assume that you are familiar with both the relevant software applications and operating system commands. Review the relevant operating system commands and the pertinent sections of your application software's user's manual before performing the installation.

## 3.2 Introduction

The Intel® Chipset Software Installation utility installs to the target system the Windows INF files that outline to the operating system how the chipset components will be configured. This is needed for the proper functioning of the following features:

- Core PCI and ISA PnP services
- IDE Ultra ATA 100/66/33 and Serial ATA interface support
- USB 1.1/2.0 support
- Identification of Intel® chipset components in the Device Manager
- Integrates superior video features. These include filtered sealing of 720 pixel DVD content, and MPEG-2 motion compensation for software DVD

**Note!** *This utility is used for the following versions of Windows system, and it has to be installed before installing all the other drivers:*



*Windows 2000*

*Windows NT*

*Windows XP*

### 3.3 Windows XP Driver Setup

Insert the driver CD into your system's CD-ROM drive. You can see the driver folders items. Move the mouse cursor over the folder "INF". In INF folder, you can click "setup.exe" to complete the implement of the driver.

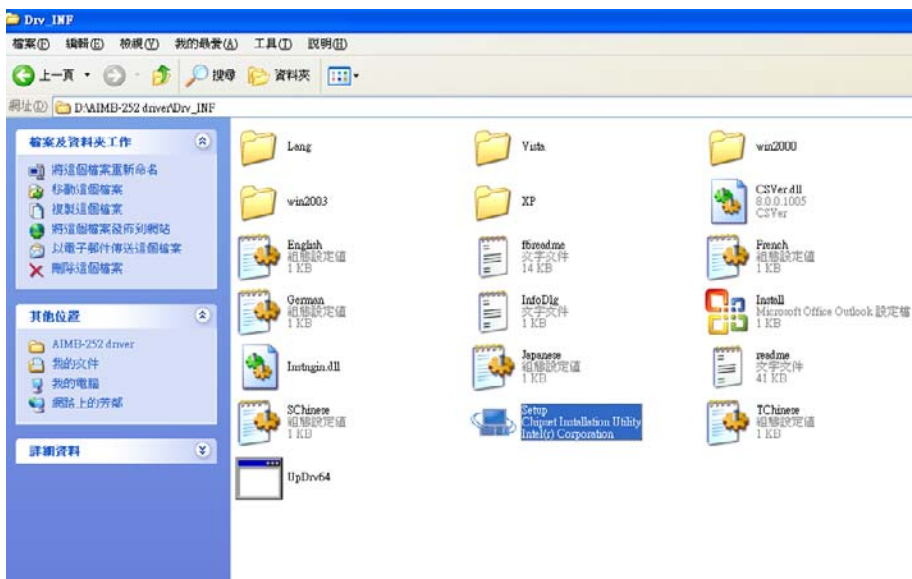
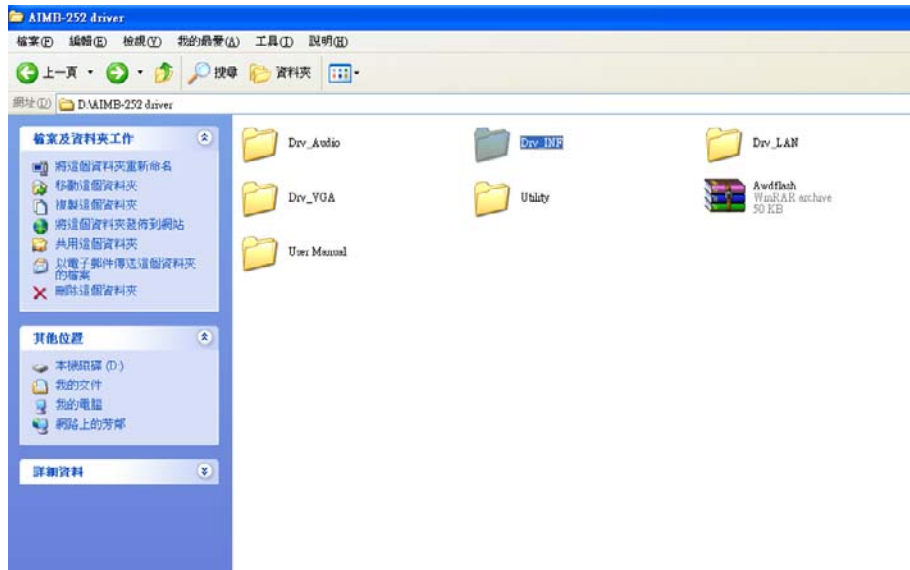



# Chapter 4

## VGA Setup

## 4.1 Introduction

The Intel 915GME/910GMLE integrated graphics controller provides an analog display port. You need to install the VGA driver to enable the function.

**Intel Graphics Media Accelerator 900:** Incorporating the latest Microsoft\* DirectX\*9 support capabilities, it allows software developers to create lifelike environments and characters. Dual independent display, enhanced display modes for widescreen flat panels, and optimized 3D support deliver an intense and realistic visual experience without requiring a separate graphics card. @ 75 Hz refresh rate).

- LVDS Interface:LVDS1: single channel 18-bit/dual channel 36-bit, LVDS2: single channel 24-bit/dual channel 48-bit. LVDS2 is only available in AIMB-252G2-M0A1E sku,(detail please see 4.3 Dual display supporting table) supporting up to WUXGA(1600X1200) panel resolution

## 4.2 Windows XP Driver Setup

**Note!** Before installing this driver, make sure the CSI utility has been installed in your system. See Chapter 3 for information on installing the CSI utility.



Insert the driver CD into your system's CD-ROM drive. In a few seconds, the software installation main menu appears, as shown in the following figure.

The following installation procedure is for Windows XP. For other operating systems, please do a manual installation.

Move the mouse cursor over the folder "Drv\_VGA". In Drv\_VGA folder, you can click Installshield Wizard under Windows\win2k\_xp142550 to automatic complete the implement of the driver.

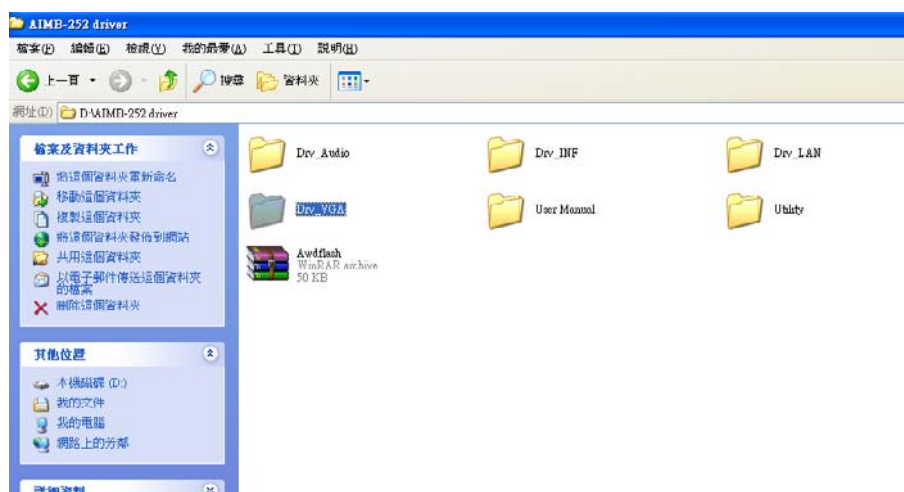



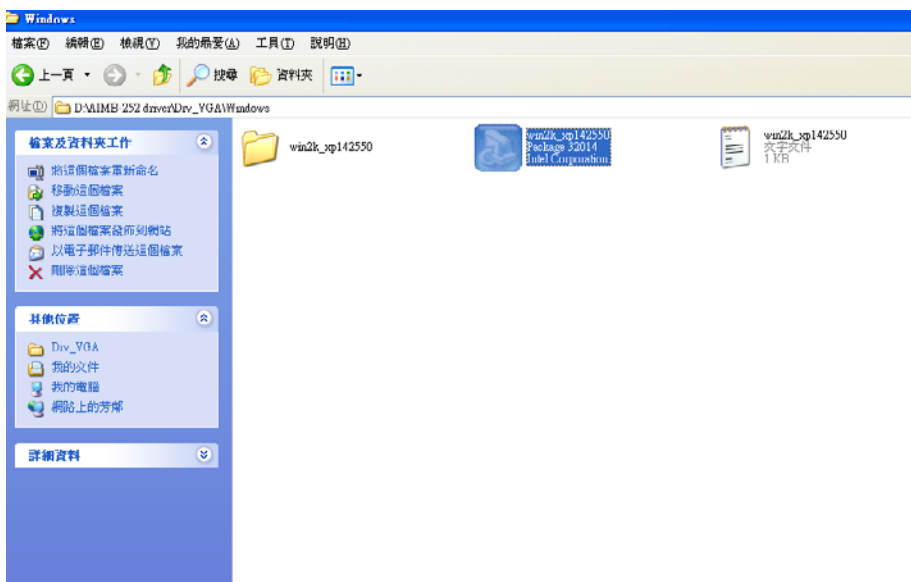
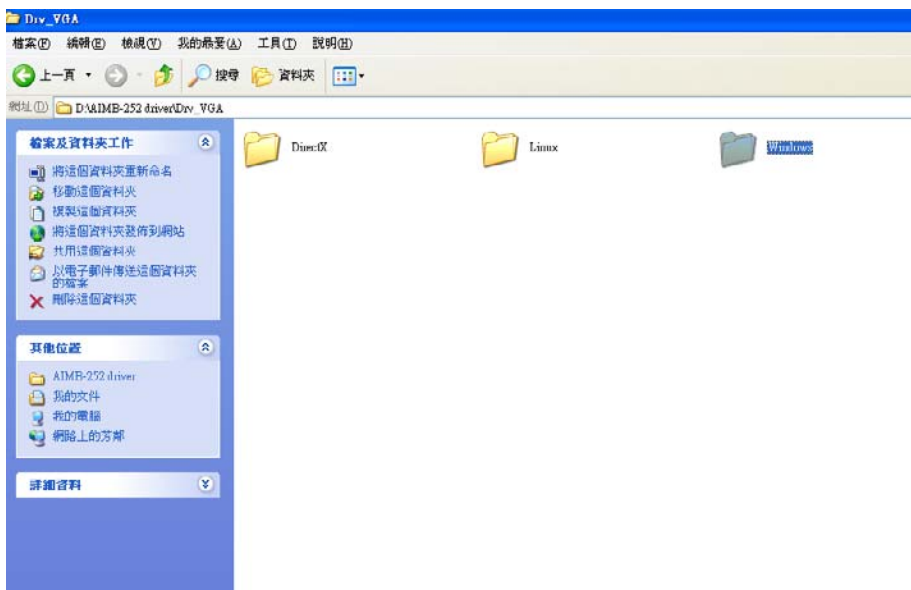

<b>BMP</b>	<b>Driver Information</b> Ver: 6.14.10.4764		<b>Panel Type</b> LVDS1: 800 * 600 LVDS2: 1280 * 1024	
	Primary Secondary	CRT	LVDS1	LVDS2
Only Display	CRT	OK	-	-
	LVDS1	-	OK	-
	LVDS2	-	-	OK
Twin Display	CRT	-	OK	OK
	LVDS1	X	-	X
	LVDS2	X	X	-
Extend Display	CRT	-	OK	OK
	LVDS1	X	-	OK
	LVDS2	X	OK	-
Clone Display	CRT	-	OK	OK
	LVDS1	X	-	X-
	LVDS2	X	X	-

<b>Driver: IEGD</b> <b>VBIOS: BMP</b>	<b>Drive rInformation</b> Ver: 8.0		<b>Panel Type</b> LVDS1: 800 * 600 LVDS2: 1280 * 1024	
	Primary Secondary	CRT	LVDS1	LVDS2
Only Display	CRT	OK	-	-
	LVDS1	-	OK	-
	LVDS2	-	-	OK
Twin Display	CRT	-	X (No item)	OK
	LVDS1	X (No item)	-	OK
	LVDS2	X (No item)	X (No item)	-
Extend Display	CRT	-	X (No item)	X (No item)
	LVDS1	OK	-	X (No item)
	LVDS2	OK	OK	-
Clone Display	CRT	-	X (No item)	X (No item)
	LVDS1	OK	-	X (No item)
	LVDS2	OK	OK	-

# Chapter 5

## LAN Configuration

## 5.1 Introduction

The AIMB-252 features single/dual Gigabit Ethernet network interface. With the Realtek RTL8111C GbE controller designed-in, AIMB-252 implements the PCI Express host interface (PCI-E X1) in LAN connection with the maximum throughput of 2Gbps for heavy-duty industrial network application.

## 5.2 Features

Integrated 10/100/100 BASE-T transceiver

1. 10/100/1000 BASE-T triple-speed MAC
2. High-speed RISC core with 24-KB cache
3. On-chip voltage regulation
4. Supporting Wake-on-LAN (WOL) function
5. PCI Express X1 host interface

## 5.3 Installation

**Note!** Before installing the LAN drivers, make sure the CSI utility has been installed on your system. See Chapter 3 for information on installing the CSI utility.



The AIMB-252's Realtek RTL8111C Gigabit integrated controller supports all major network operating systems. However, the installation procedure varies with different operating systems. In the following sections, refer to the one that provides driver setup procedure for the operating system you are using.

## 5.4 Win XP Driver Setup (Realtek RTL8111C)

Insert the driver CD into your system's CD-ROM drive. Select the Drv\_LAN folder then click the proper Lan driver for the OS.

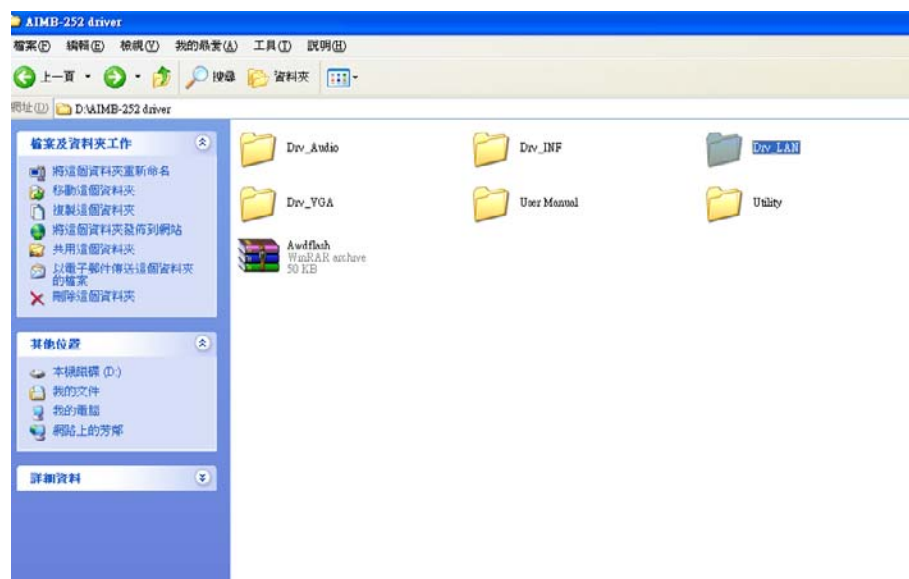

Based on different OS, choose proper LAN driver to install.

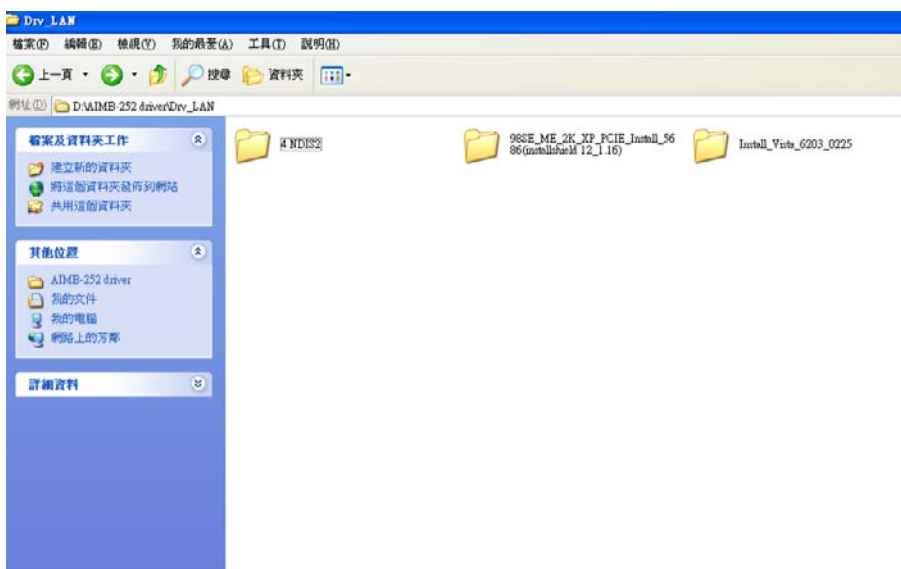
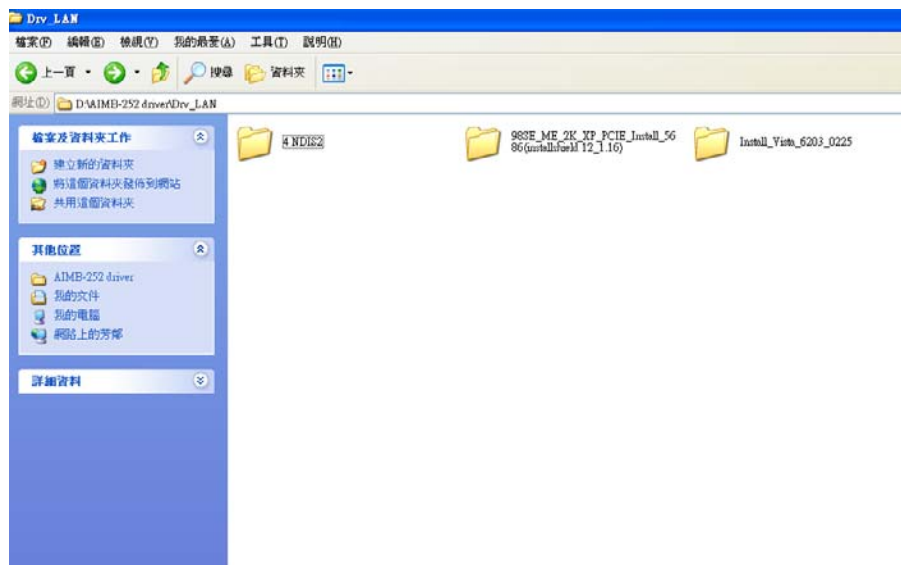



# Appendix **A**

Programming the  
Watchdog

---

## A.1 Programming the Watchdog Timer

The AIMB-252's watchdog timer can be used to monitor system software operation and take corrective action if the software fails to function after the programmed period. This section describes the operation of the watchdog timer and how to program it.

### A.1.1 Watchdog timer overview

The watchdog timer is built into the super I/O controller W83627DHG-A. It provides the following functions for user programming:

- Can be enabled and disabled by user's program.
- Timer can be set from 1 to 255 seconds or 1 to 255 minutes.
- Generates an interrupt or resets signal if the software fails to reset the timer after time-out.

### A.1.2 Programming the Watchdog Timer

The I/O port address of the watchdog timer is 2E(hex) and 2F(hex).

2E (hex) is the address port. 2F(hex) is the data port.

You must first assign the address of register by writing address value into address port 2E(hex), then write/read data to/from the assigned register through data port 2F (hex).



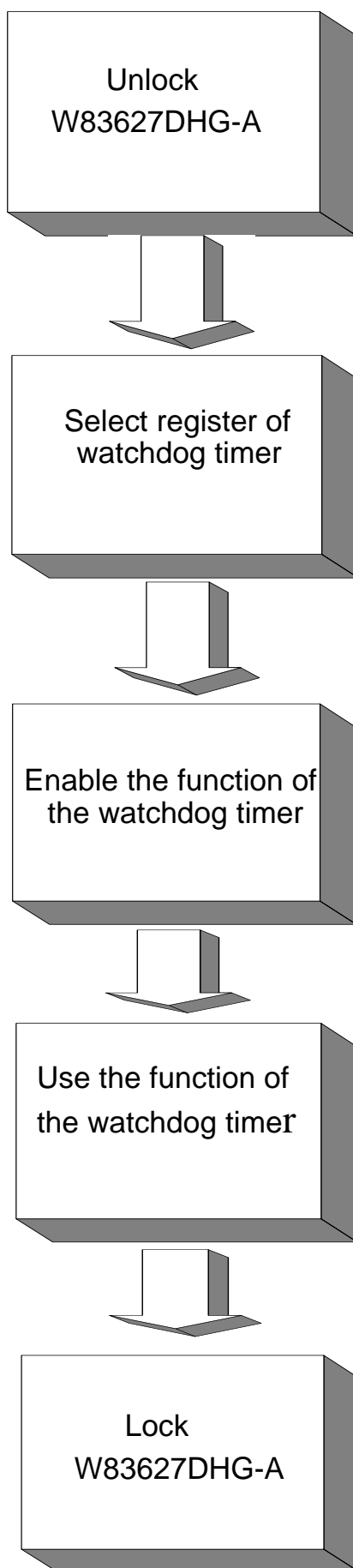

**Table A.1: Watchdog Timer Registers**

<b>Address of register (2E) Attribute</b>		
<b>Read/Write</b>	<b>Value (2F) and description</b>	
87 (hex)	-	Write this address to I/O address port 2E (hex) twice to unlock the W83627HF
07 (hex)	write	Write 08 (hex) to select register of watchdog timer.
30 (hex)	write	Write 01 (hex) to enable the function of the watchdog timer. Disabled is set as default.
F5 (hex)	write	Set seconds or minutes as units for the timer.
Write 0 to bit 3: set second as counting unit. [default]		
Write 1 to bit 3: set minute as counting unit.		
F6 (hex)	write	0: stop timer [default] 01~FF (hex): The amount of the count, in seconds or minutes, depends on the value set in register F5 (hex). This number decides how long the watchdog timer waits for strobe before generating an interrupt or reset signal. Writing a new value to this register can reset the timer to count with the new value.
F7 (hex)	read/write	Bit 6: Write 1 to enable keyboard to reset the timer, 0 to disable.[default] Bit 5: Write 1 to generate a timeout signal immediately and automatically return to 0. [default=0] Bit 4: Read status of watchdog timer, 1 means timer is "time out".
AA (hex)	-	Write this address to I/O port 2E (hex) to lock the watchdog timer.

### A.1.3 Example Program

1. Enable watchdog timer and set 10 sec. as timeout interval

```

;-----
Mov dx,2eh ; Unlock W83627DHG-A
Mov al,87h
Out dx,al
Out dx,al
;-----
Mov al,07h ; Select registers of watchdog timer
Out dx,al
Inc dx
Mov al,08h
Out dx,al
;-----
Dec dx ; Enable the function of watchdog timer
Mov al,30h
Out dx,al
Inc dx
Mov al,01h
Out dx,al
;-----
Dec dx ; Set second as counting unit
Mov al,0f5h
Out dx,al
Inc dx
In al,dx
And al,not 08h
Out dx,al
;-----
Dec dx ; Set timeout interval as 10 seconds and start counting
Mov al,0f6h
Out dx,al
Inc dx
Mov al,10
Out dx,al
;-----
Dec dx ; lock W83627DHG-A
Mov al,0aah
Out dx,al

```

2. Enable watchdog timer and set 5 minutes as timeout interval

```

;-----
Mov dx,2eh ; unlock W83627DHG-A
Mov al,87h
Out dx,al
Out dx,al

```

```

;-----
Mov al,07h ; Select registers of watchdog timer
Out dx,al
Inc dx
Mov al,08h
Out dx,al
;-----
Dec dx ; Enable the function of watchdog timer
Mov al,30h
Out dx,al
Inc dx
Mov al,01h
Out dx,al
;-----
Dec dx ; Set minute as counting unit
Mov al,0f5h
Out dx,al
Inc dx
In al,dx
Or al,08h
Out dx,al
;-----
Dec dx ; Set timeout interval as 5 minutes and start counting
Mov al,0f6h
Out dx,al
Inc dx
Mov al,5
Out dx,al
;-----
Dec dx ; lock W83627DHG-A
Mov al,0aah
Out dx,al
3. Enable watchdog timer to be reset by mouse
;-----
Mov dx,2eh ; unlock W83627DHG-A
Mov al,87h
Out dx,al
Out dx,al
;-----
Mov al,07h ; Select registers of watchdog timer
Out dx,al
Inc dx
Mov al,08h
Out dx,al
;-----

```

```

Dec dx ; Enable the function of watchdog timer
Mov al,30h
Out dx,al
Inc dx
Mov al,01h
Out dx,al
;-----
Dec dx ; Enable watchdog timer to be reset by mouse
Mov al,0f7h
Out dx,al
Inc dx
In al,dx
Or al,80h
Out dx,al
;-----
Dec dx ; lock W83627DHG-A
Mov al,0aah
Out dx,al
4. Enable watchdog timer to be reset by keyboard
;-----
Mov dx,2eh ; unlock W83627DHG-A
Mov al,87h
Out dx,al
Out dx,al
;-----
Mov al,07h ; Select registers of watchdog timer
Out dx,al
Inc dx
Mov al,08h
Out dx,al
;-----
Dec dx ; Enable the function of watchdog timer
Mov al,30h
Out dx,al
Inc dx
Mov al,01h
Out dx,al
;-----
Dec dx ; Enable watchdog timer to be strobed reset by keyboard
Mov al,0f7h
Out dx,al
Inc dx
In al,dx
Or al,40h
Out dx,al

```

```

;-----
Dec dx ; lock W83627DHG-A
Mov al,0aah
Out dx,al
5. Generate a time-out signal without timer counting
;-----
Mov dx,2eh ; unlock W83627DHG-A
Mov al,87h
Out dx,al
Out dx,al
;-----
Mov al,07h ; Select registers of watchdog timer
Out dx,al
Inc dx
Mov al,08h
Out dx,al
;-----
Dec dx ; Enable the function of watchdog timer
Mov al,30h
Out dx,al
Inc dx
Mov al,01h
Out dx,al
;-----
Dec dx ; Generate a time-out signal
Mov al,0f7h
Out dx,al ;Write 1 to bit 5 of F7 register
Inc dx
In al,dx
Or al,20h
Out dx,al
;-----
Dec dx ; lock W83627DHG-A
Mov al,0aah
Out dx,al

```

# Appendix **B**

## Pin Assignments

## B.1 IDE Hard Drive Connector (IDE1)

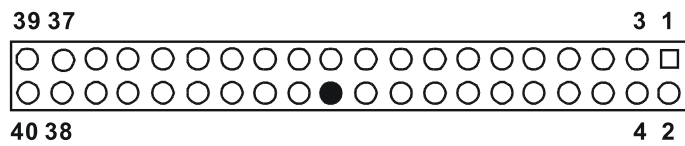

**Table B.1: IDE Hard Drive Connector (IDE1)**

Pin	Signal	Pin	Signal
1	IDE RESET*	2	GND
3	DATA 7	4	DATA 8
5	DATA 6	6	DATA 9
7	DATA 5	8	DATA 10
9	DATA 4	10	DATA 11
11	DATA 3	12	DATA 12
13	DATA 2	14	DATA 13
15	DATA 1	16	DATA 14
17	DATA 0	18	DATA 15
19	GND	20	N/C
21	DISK DMA REQUEST	22	GND
23	IO WRITE	24	GND
25	IO READ	26	GND
27	IO CHANNEL READY	28	CSEL
29	HDACKO*	30	GND
31	IDE IRQ	32	NC
33	ADDR 1	34	PDIAG
35	ADDR 0	36	ADDR 2
37	HARD DISK SELECT 0*	38	HARD DISK SELECT 1*
39	IDE ACTIVE*	40	GND

\* low active



## B.2 Parallel Port Connector (LPT1)

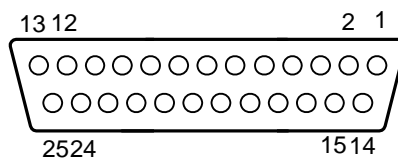
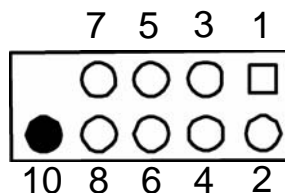

**Table B.2: Parallel Port Connector (LPT1)**

Pin	Signal	Pin	Signal
1	STROBE*	14	AUTOFD*
2	D0	15	ERR
3	D1	16	INIT*
4	D2	17	SLCTINI*
5	D3	18	GND
6	D4	19	GND
7	D5	20	GND
8	D6	21	GND
9	D7	22	GND
10	ACK*	23	GND
11	BUSY	24	GND
12	PE	25	GND
13	SLCT		

\* low active

## B.3 USB Connector (USB56,USB78)



**Table B.3: USB5/USB6 Connector (USB56)**

Pin	USB1 Signal	Pin	USB2 Signal
1	+5 V	2	+5 V
3	LP5-	4	LP5+
5	LP5+	6	LP5-
7	GND	8	GND
9	NC	10	GND

## B.4 VGA Connector (VGA1)

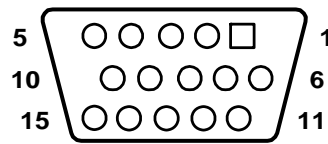

**Table B.4: VGA Connector (VGA1)**

Pin	Signal	Pin	Signal
1	RED	9	VCC
2	GREEN	10	GND
3	BLUE	11	N/C
4	N/C	12	SDAT
5	GND	13	H-SYNC
6	GND	14	V-SYNC
7	GND	15	SCLK
8	GND		

## B.5 RS-232 Serial Port (COM1)

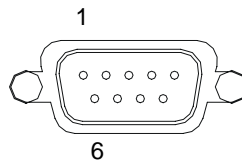

**Table B.5: Rs-232 Serial Port (COM1)**

Pin	Signal
1	DCD
2	SIN
3	SOUT
4	DTR
5	GND
6	DSR
7	RTS
8	CTS
9	RI

## B.6 RS-232 Serial Port (COM2 ~ COM5)

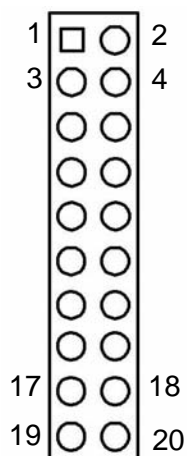

**Table B.6: RS-232 Serial Port (COM23)**

Pin	Signal	Pin	Signal
1	DCCD2_N	2	DDSR2_N
3	RRXD2	4	RRTS2_N
5	TTXD2	6	CCTS2_N
7	DDTR2_N	8	RRI2_N
9	GND	10	GND
11	DCCD3_N	12	DDSR3_N
13	RRXD3	14	RRTS3_N
15	TTXD3	16	CCTS3_N
17	DDTR3_N	18	RRI3_N
19	GND	20	GND

**Table B.7: RS-232 Serial Port (COM45)**

Pin	Signal	Pin	Signal
1	DCCD4_N	2	DDSR4_N
3	RRXD4	4	RRTS4_N
5	TTXD4	6	CCTS4_N
7	DDTR4_N	8	RRI4_N
9	GND	10	GND
11	DCCD5_N	12	DDSR5_N
13	RRXD5	14	RRTS5_N
15	TTXD5	16	CCTS5_N
17	DDTR5_N	18	RRI5_N
19	GND	20	GND

## B.7 PS/2 Keyboard/ Mouse Connector (KBMS1)

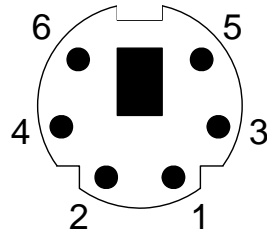
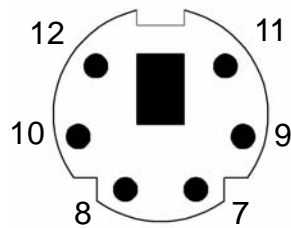

**Table B.8: PS/2 Keyboard/ Mouse Connector (KBMS1)**

Pin	Signal	Pin	Signal
1	KB DATA	2	NC
7	MS DATA	6	NC
3	GND	8	NC
4	VCC	9	GND
5	KB CLOCK	10	VCC
11	MS CLOCK	12	NC

## B.8 CPU Fan Power Connector (CPUFAN1)

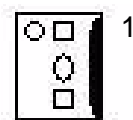
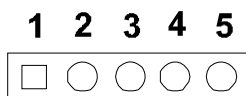

**Table B.9: CPU Fan Power Connector (CPUFAN1)**

Pin	Signal
1	FAXIO
2	+12 V
3	GND
4	NC

## B.9 Power LED & Keyboard Lock Connector (JFP3)

You can use an LED to indicate when the single board computer is on. Pin 1 of JFP3 supplies the LED's power, and Pin 3 is the ground.

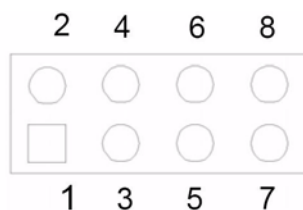

**Table B.10: Power LED and Keylock Connector (JFP3)**

Pin	Function
1	LED power (+5 V)
2	NC
3	GND
4	KEYLOCK#
5	GND

## B.10 External Speaker Connector (JFP2/ SPEAKER)

The single board computer has its own buzzer. You can also connect it to the external speaker on your computer chassis.



**Table B.11: External Speaker Connector (JFP2/SPEAKER)**

Pin	Signal	Pin	Signal
1	SPK+	2	HDDLED+
3	NC	4	HDDLED-
5	SPK_IN	6	SMB_DAATA
7	SPK-	8	SMB_CLK

## B.11 Reset Connector (JFP1/ RESET)

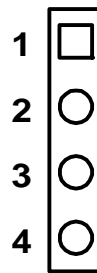

**Table B.12: Reset Connector (JFP1/ RESET)**

Pin	Signal
1	PWR_BTN#
2	GND
3	RESET
4	GND

## B.12 HDD LED Connector (JFP2/ HDDLED)

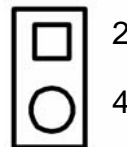

**Table B.13: HDD LED Connector (JFP2/ HDDLED)**

Pin	Signal
2	HDDLED+
4	HDDLED-

## B.13 ATX Soft Power Switch (JFP1/ PWR\_SW)



**Table B.14: ATX Soft Power Switch (JFP1/ PWR\_SW)**

Pin	Signal
1	PWR-BTN
2	GND

## B.14 AC-97 Audio Interface (FPAUD1)

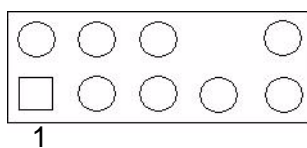

**Table B.15: AC-97 Audio Interface (FPAUD1)**

1 MIC-IN	2 GND
3 MIC_VCC	4 VCC
5 LRR	6 LOUT_R
7 JDO	8 NC
9 LRL	10 LOUT_L

## B.15 SM Bus Connector (JFP2)

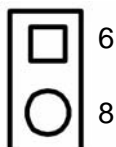

**Table B.16: SM Bus Connector (JFP2)**

Pin	Signal
6	SMB_DATA
8	SMB_CLK

## B.16 GPIO Pin Header (GPIO1)

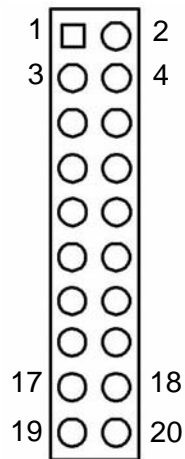
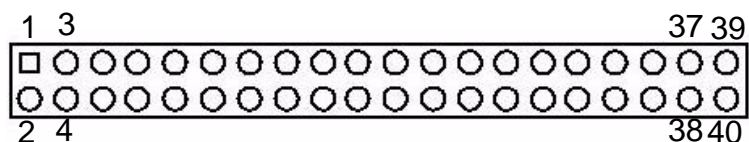

**Table B.17: GPIO Pin Header (GPIO1)**

Pin	Signal	Pin	Signal
1	DIO_GP20	2	DIO_GP10
3	DIO_GP21	4	DIO_GP11
5	DIO_GP22	6	DIO_GP12
7	DIO_GP23	8	DIO_GP13
9	DIO_GP24	10	DIO_GP14
11	DIO_GP25	12	DIO_GP15
13	DIO_GP26	14	DIO_GP16
15	DIO_GP27	16	DIO_GP17
17	SMBCLK_PCI	18	SMBDATA_PCI
19	GND	20	VCC5_DIO



## B.17 LVDS Connector (LVDS1/LVDS2)



**Table B.18: LVDS Connector (LVDS1/2)**

Pin	Signal	Pin	Signal
1	VDDSAFE_1	21	VDDSAFE_2
2	GND_1	22	GND_7
3	VDDSAFE_3	23	VDDSAFE_4
4	OD0-	24	ED0-
5	OD0+	25	ED0+
6	GND_2	26	GND_8
7	OD1-	27	ED1-
8	OD1+	28	ED1+
9	GND_3	29	GND_9
10	OD2-	30	ED2-
11	OD2+	31	ED2+
12	GND_4	32	GND_10
13	OCK-	33	ECK-
14	OCK+	34	ECK+
15	GND_5	35	GND_11
16	DDC_CLK	36	DDC_DAT
17	GND_6	37	GND_12
18	OD3-	38	ED3-
19	OD3+	39	ED3+
20	HPLG	40	VCON

## B.18 LVDS Power Jumper (JLV1, JLV2)

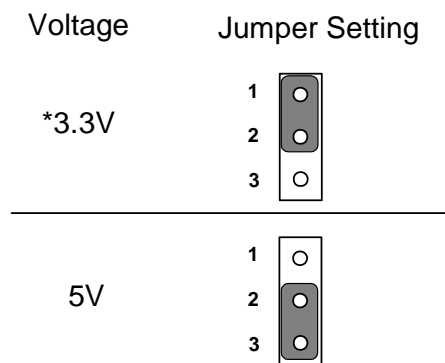

\*default setting

**Table B.19: LVDS Power Jumper (JLV1, JLV2)**

Pin	Signal
1	VCC3
2	VDD_LCD
3	VCC

## B.19 LVDS Invert (INV1, INV2)



**Table B.20: LVDS Invert (INV1, INV2)**

Pin	Signal
1	VCC12
2	GND
3	BKLTEN
4	VBR
5	VCC

## B.20 System I/O Ports

**Table B.21: System I/O Ports**

Addr. range (Hex)	Device
000-01F	DMA controller
020-021	Interrupt controller 1, master
022-023	Chipset address
040-05F	8254 timer
060-06F	8042 (keyboard controller)
070-07F	Real-time clock, non-maskable interrupt (NMI) mask
080-09F	DMA page register
0A0-0BF	Interrupt controller 2
0C0-0DF	DMA controller
0F0	Clear math co-processor
0F1	Reset math co-processor
0F8-0FF	Math co-processor
1F0-1F8	Fixed disk
200-207	Game I/O
278-27F	Parallel printer port 2 (LPT3)
290-297	On-board hardware monitor
2F8-2FF	Serial port 2
300-31F	Prototype card
360-36F	Reserved
378-37F	Parallel printer port 1 (LPT2)
380-38F	SDLCm bisynchronous 2
3A0-3AF	Bisynchronous 1
3B0-3BF	Monochrome display and printer adapter (LPT1)
3C0-3CF	Reserved
3D0-3DF	Color/graphics monitor adapter
3F0-3F7	Diskette controller
3F8-3FF	Serial port 1

## B.21 DMA Channel Assignments

**Table B.22: DMA Channel Assignments**

Channel	Function
0	Available
1	Available
2	Floppy disk (8-bit transfer)
3	Available
4	Cascade for DMA controller 1
5	Available
6	Available
7	Available

## B.22 Interrupt Assignments

**Table B.23: Interrupt Assignments**

Priority	Interrupt#	Interrupt Source
1	NMI	Parity error detected
2	IRQ0	Interval timer
3	IRQ1	Keyboard
-	IRQ2	Interrupt from controller 2 (cascade)
4	IRQ8	Real-time clock
5	IRQ9	Cascaded to INT 0A (IRQ 2)
6	IRQ10	Serial communication port 4
7	IRQ11	Serial communication port 5
8	IRQ12	PS/2 mouse
9	IRQ13	INT from co-processor
10	IRQ14	Primary IDE Channel
12	IRQ3	Serial communication port 2
13	IRQ4	Serial communication port 1
14	IRQ5	Serial communication port 3
15	IRQ6	Diskette controller (FDC)
16	IRQ7	Parallel port 1 (print port)

## B.23 1st MB Memory Map

**Table B.24: 1st MB Memory Map**

Addr. range (Hex)	Device
E0000h - FFFFFh	BIOS
CC000h - DFFFFh	Unused
C0000h - CBFFFh	VGA BIOS
A0000h - BFFFFh	Video Memory
00000h - 9FFFFh	Base memory

## B.24 PCI Bus Map

**Table B.25: PCI Bus Map**

Function Signals	Device ID	INT# pin	GNT	REQ
PCI slot 1	AD31	INT B, C, D, A	SNT0	REQ0



*Trusted ePlatform Services*

**ADVANTECH**

**[www.advantech.com](http://www.advantech.com)**

Please verify specifications before quoting. This guide is intended for reference purposes only.

All product specifications are subject to change without notice.

No part of this publication may be reproduced in any form or by any means, electronic, photocopying, recording or otherwise, without prior written permission of the publisher.

All brand and product names are trademarks or registered trademarks of their respective companies.

© Advantech Co., Ltd. 2008