

ACP-4362 / 4360

**4U-High Rackmount Industrial
Chassis with
Six Mobile SATA HDD Trays**

User Manual

Copyright

This documentation and the software included with this product have been copyrighted by Advantech Co., Ltd. in December, 2006. All rights are reserved. Advantech Co., Ltd. reserves the right to make improvements in the products described in this manual at any time without notice.

No part of this manual may be reproduced, copied, translated or transmitted in any form or by any means without the prior written permission of Advantech Co., Ltd. Information provided in this manual is intended to be accurate and reliable. However, Advantech Co., Ltd. assumes no responsibility for its use, or for any infringements of the rights of third parties which may result from its use.

Acknowledgements

Intel®, Pentium® 4, and Celeron® are trademarks of Intel Corporation. The ACP-4362, ACP-4360, AIMB-744, AIMB-762, PCE-5B12, PCE-7B13, PCE-5120, and PCE-7120 are trademarks of Advantech Co., Ltd. All other product names or trademarks are the properties of their respective owners.

On-line Technical Support

For technical support and service, please visit our support website at:
<http://www.advantech.com/support>

Part No. 2002436200
Printed in China

1st Edition
December, 2006

Safety Instructions

1. Read these safety instructions carefully
2. Keep this user manual for later reference.
3. Disconnect this equipment from AC outlet before cleaning. Do not use liquid or spray detergents for cleaning.
4. For pluggable equipment, the power outlet shall be installed near the equipment and shall be easily accessible.
5. Keep this equipment away from humidity.
6. Put this equipment on a reliable surface during installation. Dropping it or letting it fall could cause damage.
7. Do not leave this equipment in an environment unconditioned where the storage temperature under 0° C (32° F) or above 40° C (104° F), it may damage the equipment.
8. The openings on the enclosure are for air convection hence protects the equipment from overheating. **DO NOT COVER THE OPENINGS.**
9. Make sure the voltage of the power source is correct before connecting the equipment to the power outlet.
10. Place the power cord such a way that people can not step on it. Do not place anything over the power cord. The voltage and current rating of the cord should be greater than the voltage and current rating marked on the product.
11. All cautions and warnings on the equipment should be noted.
12. If the equipment is not used for long time, disconnect it from the power source to avoid being damaged by transient over-voltage.
13. Never pour any liquid into ventilation openings. This could cause fire or electrical shock.
14. Never open the equipment. For safety reasons, the equipment should be opened only by qualified service personnel.
15. If any of the following situations arises, get the equipment checked by service personnel:
 - a. The power cord or plug is damaged.
 - b. Liquid has penetrated into the equipment.
 - c. The equipment has been exposed to moisture.

- d. The equipment does not work well or you cannot get it to work according to user manual.
 - e. The equipment has been dropped and damaged.
 - f. The equipment has obvious signs of breakage.
16. CAUTION: The computer is provided with a battery-powered real-time clock circuit. There is a danger of explosion if battery is incorrectly replaced. Replace only with same or equivalent type recommended by the manufacture. Discard used batteries according to the manufacturer's instructions.
17. THE COMPUTER IS PROVIDED WITH CD DRIVES COMPLY WITH APPROPRIATE SAFETY STANDARDS INCLUDING IEC 60825.

<p>CLASS 1 LASER PRODUCT KLASSE 1 LASER PRODUKT</p>

18. This device complies with Part 15 of the FCC rules. Operation is subject to the following two conditions:
- (1) this device may not cause harmful interference, and
 - (2) this device must accept any interference received, including interference that may cause undesired operation.
19. CAUTION: Always completely disconnect the power cord from your chassis whenever you work with the hardware. Do not make connections while the power is on. Sensitive electronic components can be damaged by sudden power surges.
20. CAUTION: Always ground yourself to remove any static charge before touching the motherboard, backplane, or add-on cards. Modern electronic devices are very sensitive to static electric charges. As a safety precaution, use a grounding wrist strap at all times. Place all electronic components on a static-dissipative surface or in a static-shielded bag when they are not in the chassis.
21. CAUTION: Any unverified component could cause unexpected damage. To ensure the correct installation, please always use the components (ex. screws) provided with the accessory box.

A Message to the Customer

Advantech customer services

Each and every Advantech product is built to the most exacting specifications to ensure reliable performance in the harsh and demanding conditions typical of industrial environments. Whether your new Advantech equipment is destined for the laboratory or the factory floor, you can be assured that your product will provide the reliability and ease of operation for which the name Advantech has come to be known. Your satisfaction is our primary concern. Here is a guide to Advantech's customer services.

To ensure you get the full benefit of our services, please follow the instructions below carefully.

Technical support

We want you to get the best performance possible from your products. If you run into technical difficulties, we are here to help. For the most frequently asked questions, you can easily find answers in your product documentation. These answers are normally a lot more detailed than the ones we can give over the phone.

Please consult this manual first. If you still cannot find the answer, gather all the information or questions that apply to your problem, and with the product close at hand, call your dealer. Our dealers are well trained and ready to give you the support you need to get the most from your Advantech products. In fact, most problems reported are minor and can be easily solved over the phone.

In addition, free technical support is available from Advantech engineers every business day. We are always ready to give advice about application requirements or specific information on the installation and operation of any of our products.

Product Warranty

Advantech warrants to you, the original purchaser, that each of its products will be free from defects in materials and workmanship for two years from the date of purchase.

This warranty does not apply to any products which have been repaired or altered by persons other than repair personnel authorized by Advantech, or which have been subject to misuse, abuse, accident or improper installation. Advantech assumes no liability under the terms of this warranty as a consequence of such events.

If an Advantech product is defective, it will be repaired or replaced at no charge during the warranty period. For out-of-warranty repairs, you will be billed according to the cost of replacement materials, service time and freight. Please consult your dealer for more details.

If you think you have a defective product, follow these steps:

1. Collect all the information about the problem encountered, for example, type of PC, CPU speed, Advantech products used, other hardware and software used, etc. Note anything abnormal and list any on-screen messages you get when the problem occurs.
2. Call your dealer and describe the problem. Please have your manual, product, and any helpful information readily available.
3. If your product is diagnosed as defective, obtain an RMA (return material authorization) number from your dealer. This allows us to process your return more quickly.
4. Carefully pack the defective product, a fully-completed Repair and Replacement Order Card and a photocopy proof of purchase date (such as your sales receipt) in a shippable container. A product returned without proof of the purchase date is not eligible for warranty service.
5. Write the RMA number visibly on the outside of the package and ship it prepaid to your dealer.

Initial Inspection

Before you install your backplane, please make sure that the following materials have been shipped:

- ACP-4362 / 4360 Chassis
- User Manual
- Warranty Card
- Accessory box with a package of screws (for fastening the backplane or motherboard, slim-type optical disk drive, other disk drives, ear handles, etc.), a small IDE interface converter for slim-type optical disk drive (ex. CD-ROM drive), a pair of keys, a pc of EMI spring shielding (for backplane version), a pair of ear handles, 15 pcs rubber cushions (backplane version) or 7 pcs (motherboard version), and a cable for connecting the SATA HDD backplane and the optional RAID card.

If any of these items are missing or damaged, contact your distributor or sales representative immediately. We have carefully inspected the ACP-4362 / 4360 mechanically and electrically before shipment. It should be free of marks and scratches and in perfect working order upon receipt. As you unpack the ACP-4362 / 4360, check it for signs of shipping damage. (For example, damaged box, scratches, dents, etc.) If it is damaged or it fails to meet the specifications, notify our service department or your local sales representative immediately. Also, please notify the carrier. Retain the shipping carton and packing material for inspection by the carrier. After inspection, we will make arrangements to repair or replace the unit.

Contents

Chapter 1	General Information	2
1.1	Introduction	2
1.2	Specifications	2
1.3	Power Supply Options	4
	Table 1.1:Power supply options.....	4
1.4	Environmental Specifications	5
	Table 1.2:Environment specifications	5
1.5	Dimension Diagram	6
	Figure 1.1:Dimension diagram	6
Chapter 2	System Setup.....	8
2.1	Removing the Chassis Cover	8
	Figure 2.1:Removing the chassis top cover	8
2.2	Installing the Backplane or Motherboard.....	9
	Figure 2.2:Yellow label indicating copper stub locations....	10
	Figure 2.3:Installing the backplane.....	10
	Figure 2.4:Installing a motherboard.....	11
2.3	Installing CPU Card or Add-on Card.....	12
	Figure 2.5:Installing a full-length card	12
2.4	Hold-down clamp.....	13
	Figure 2.6:Installing rubber cushions and hold-down clamp	13
2.5	Installing Disk Drives.....	14
2.5.1	Installing HDD or FDD or Slim-type Optical Disk Drive	14
	Figure 2.7:Installing 3.5" HDD or FDD	14
	Figure 2.8:Converter for slim-type optical disk drive ..	15
	Figure 2.9:Installing the slim-type optical disk drive ...	15
2.5.2	Installing SATA HDD	16
	Figure 2.10:Pushing up the latch & removing the mobile tray	16
	Figure 2.11:Installing a SATA HDD.....	16
2.6	Attaching the Ears and Handles	17
	Figure 2.12:Attaching the ears and handles.....	17
Chapter 3	Operation	20
3.1	The Front Panel	20
	Figure 3.1:Closed front panel	20
	Figure 3.2:Open front panel.....	20
3.1.1	Switch, Buttons and I/O Interfaces	20
3.1.2	LED indicators for System Status.....	21
	Table 3.1:LED Indicator functions	21

3.1.3	LED Indicators for SATA HDD Power & Status.....	22
	Table 3.2:SATA HDD LED indicator functions for ACP-4362	22
	Table 3.3:SATA HDD LED indicator functions for ACP-4360	22
3.2	The Rear Panel	23
	Figure 3.3:Rear panel of backplane version	23
	Figure 3.4:Rear panel of motherboard version	23
3.3	Replacing the Cooling Fan.....	24
3.3.1	Replacing the 12 cm fan	24
	Figure 3.5:Replacing the cooling fan.....	24
3.3.2	Replacing the fan behind the SATA backplane.....	25
	Figure 3.6:Replacing the fan behind the SATA HDD backplane	25
3.4	Cleaning the Filters	26
	Figure 3.7:Replacing the filters	26
3.5	Replacing the Power Supply	27
3.5.1	Replacing the Single PS/2 Power Supply	27
	Figure 3.8:Replacing the single power supply.....	27
3.5.2	Replacing the Redundant Power Supply Module.....	28
	Figure 3.9:Replacing the power supply module	28
	Figure 3.10:Power cord plugs orientation on the socket	28

Chapter 4 SATA HDD Backplane, Alarm and RAID Application for ACP-436230

4.1	SATA HDD Backplane Layout.....	30
	Figure 4.1:Front side layout of the SATA HDD backplane. 30	
	Figure 4.2:Back side layout of the SATA HDD backplane . 31	
4.2	SATA HDD Backplane Specifications	31
4.2.1	Connectors & Pin Definitions for SATA & RAID Related... 31	
	Table 4.1:Mobile SATA HDD connectors and LEDs on front side	31
	Table 4.2:SATA cable connectors on rear side	32
	Table 4.3:PWR1~PWR3, Power connectors	32
	Table 4.4:CN1, SATA RAID card connector (only for ACP-4362).....	32
	Table 4.5:JP2, Power and status LED connector for mo- bile SATA HDD (only for ACP-4362).....	32
	Table 4.6:JP3, Reserved firmware connector (only for ACP-4362).....	32
4.2.2	Connectors & Pin Definition for Alarm Specifications 33	
	Table 4.7:CN2, Alarm reset connector (only for ACP-4362)... 33	
	Table 4.8:CN3, Second thermal sensor connector (only for ACP-4362)	33
	Table 4.9:CN4, Third thermal sensor connector.....	33
	Table 4.10:CN5, Output connector to LED board (only	

	for ACP-4362)	33
	Table 4.11:CN6, Voltage detection input connector (only for ACP-4362)	33
	Table 4.12:CN7, Power fail input (only for ACP-4362)	33
4.2.3	Jumper and Switch Settings	34
	Figure 4.3:Thermal sensor location	34
	Table 4.13:JP1, Buzzer jumper (only for ACP-4362) ..	34
	Table 4.14:JP4, HDD LED connector (only for ACP-4362) ...	34
	Table 4.15:FAN1~FAN4, Fan connectors (ACP-4360 only has FAN3 & FAN4)	34
	Table 4.16:FAN5, Reserved fan connector detecting speed of the 3rd to 7th fan	34
	Table 4.17:SW2, Thermal sensor number setting (only for ACP-4362).....	35
	Table 4.18:SW1, Fan number setting (only for ACP-4362)	35
	Table 4.19:JP1, Buzzer jumper (only for ACP-4362) ..	35
4.3	SATA HDD Cage.....	36
4.4	RAID Application	36
	Figure 4.4:Connect the RAID card to SATA HDD backplane. 37	

Chapter 5 Alarm Board for ACP-436040

5.1	Alarm Board Layout.....	40
	Figure 5.1:Alarm board layout.....	40
5.2	Alarm Board Specifications	41
	5.2.1 Connectors, Jumper and Pin Definition.....	41
	5.2.2 Switch Settings	43
5.3	Thermal Sensor	45
	Figure 5.2:Thermal sensor location	45
	Figure 5.3:Thermal sensor module	45

Appendix A Exploded Diagram and Parts List48

A.1	Exploded Diagram and Parts List.....	48
	Figure A.1: Exploded diagram.....	48
	Table A.1:Parts list	49

Appendix B Backplane, Motherboard, and RAID Card Options52

B.1	Backplane Options	52
	Table B.1:PICMG 1.3 Backplane options	52
B.2	Motherboard Options	52
	Table B.2:ATX Motherboard options.....	52
B.3	SATA RAID Card Options	53
	Table B.3:SATA RAID card options.....	53

B.4	Recommended Configurations.....	53
	Table B.4:Recommended configurations	53
B.5	Backplane and Motherboard Options for ACP-4360	54

CHAPTER

1

General Information

Chapter 1 General Information

1.1 Introduction

ACP-4362 / 4360 is a 4U-high rackmount industrial computer chassis for high-performance and high-capacity computing platforms. It meets a variety of application needs for filing, printing, e-mails and webserving. This powerful computing server includes full disk array storage for minimizing the system downtime, especially in mission-critical computer telephony applications, industrial automation, and factory management. A wide range of standard computing peripherals can be integrated with the chassis to meet different application needs for operation under harsh conditions 24 hours a day, 7 days a week.

1.2 Specifications

- **Construction:** Heavy-duty steel
- **Disk Drive Capacity:** One slim-type optical disk drive bay and one 3.5" disk drive bay (for FDD or internal HDD)
- **Mobile SATA HDD Storage Device:** Supports up to six 3.5" SATA HDDs. Each mobile SATA HDD tray has a latch for protection and a pair of LEDs for displaying the HDD power and HDD activity status.
- **LED Indicators on Front Panel:** Bi-color LEDs (green/red) for Power, Temperature, and Fan status; single-color LEDs (green) for HDD activity and LAN status. For the SATA storage, each mobile tray has a single-color LED (green) that displays SATA HDD power and a bi-color LED (blue/red) that displays SATA HDD status.
- **Switch and Buttons on Front Panel:** Power switch, System Reset button and Alarm Reset button.
- **Front I/O Interfaces:** Dual USB ports
- **Rear I/O Interfaces:** Reserved five 9-pin D-SUB and one 68-pin SCSI openings for the motherboard version; reserved one 9-pin D-SUB opening for the backplane version
- **Security Protection:** The mobile SATA storage system, power switch, system reset button, alarm reset button and USB ports are all behind the lockable door.

- **Cooling System:** One 12 cm x 12 cm (114 CFM) hot-swappable cooling fan; two 8 cm x 8 cm (47 CFM) fans behind the SATA HDD backplane.
- **Air Filters:** Two easily maintained reusable filters near the front of the system fan and behind the front door.
- **Weight:** 19 kg (41.8 lbs)
- **Dimensions (W x H x D):** 482 x 177 x 500 mm (19" x 7" x 19.7")

1.3 Power Supply Options

Table 1.1: Power supply options

Model Name	PS-400ATX-ZBE	RPS-400ATX-ZE
Watt	400 W (ATX, PFC) (single PS/2)	400 W (ATX, PFC) (1+1 redundant)
Input rating	100 ~ 240 Vac (Full range)	100 ~ 240 Vac (Full range)
Output voltage	+5 V @ 35 A, +3.3 V @ 25 A, +12 V @ 30 A, -5 V @ 0.8 A, -12 V @ 1 A, +5 Vsb @ 2 A	+5 V @ 35 A, +3.3 V @ 25 A, +12 V @ 28 A, -5 V @ 0.5 A, -12 V @ 1.2 A, +5 Vsb @ 2 A
Minimum load	+5 V @ 3 A, +3.3 V @ 1 A, +12 V @ 1 A, +5 Vsb @ 0.1 A	+5 V @ 3 A, +3.3 V @ 1 A, +12 V @ 2 A, +5 Vsb @ 0.1 A
MTBF	91,000 hours @ 25° C	100,000 hours @ 25° C
Safety	UL/TUV/CB/CCC	UL/TUV/CB/CCC
Model Name	PS-500ATX-ZE	PS-700ATX-ZE
Watt	500 W (ATX, PFC) (single PS/2)	700 W (ATX, PFC) (single PS/2+)
Input rating	100 ~ 240 Vac (Full range)	100 ~ 240 Vac (Full range)
Output voltage	+5 V @ 40 A, +3.3 V @ 30 A, +12 V @ 32 A, -5 V @ 0.8 A, -12 V @ 1 A, +5 Vsb @ 2 A	+5 V @ 50 A, +3.3 V @ 45 A, +12 V @ 36 A, -5 V @ 0.8 A, -12 V @ 0.1 A, +5 Vsb @ 2 A
Minimum load	+5 V @ 2.5 A, +3.3 V @ 1 A, +12 V @ 1 A, +5 Vsb @ 0.1 A	+5 V @ 3 A, +3.3 V @ 1 A, +12 V @ 2 A, +5 Vsb @ 0.1 A
MTBF	98,000 hours @ 25° C	72,000 hours @ 25° C
Safety	UL/TUV/CB/CCC	UL/TUV/CB/CCC

1.4 Environmental Specifications

Table 1.2: Environment specifications

Environment	Operating	Non-operating
Temperature	0 to 40°C (32 to 104°F)	-20 to 60°C (-4 to 140°F)
Humidity	10 to 85% @ 40°C, non-condensing	10 to 95% @ 40°C, non-condensing
Vibration	1G rms	2G
Shock	10G with 11 ms duration, half sine wave	30G
Altitude	0 to 3,048 m (0 ~ 10,000 ft)	
Safety	CE compliant	

1.5 Dimension Diagram

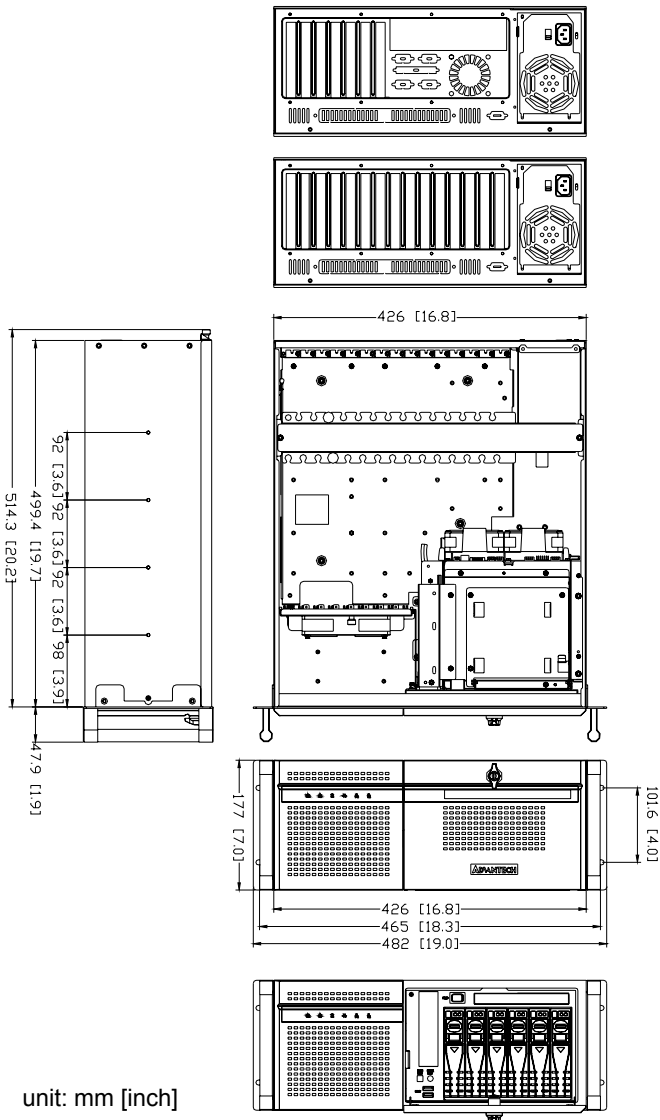

Figure 1.1: Dimension diagram

CHAPTER

2

System Setup

Chapter 2 System Setup

The following procedures instruct users to install the backplane/mother-board, add-on cards, and disk drives into the ACP-4362 / 4360 chassis. Please refer to Appendix A, Exploded Diagram, for all the detailed parts of ACP-4362 / 4360.

Note: *Use caution when installing or operating the components with the chassis open. Be sure to turn off the power, unplug the power cord and ground yourself by touching the metal chassis before you handle any components inside the machine.*

2.1 Removing the Chassis Cover

To remove the cover of ACP-4362 / 4360, please proceed as below.

1. Loosen two thumb screws on the rear of the top cover.
2. Pull the chassis top cover backwards and then lift it up.

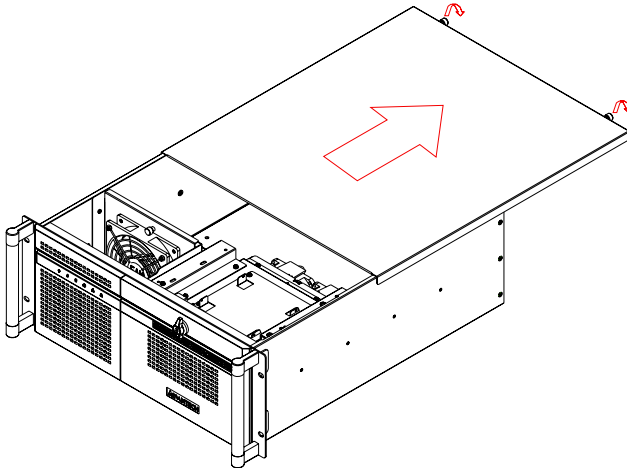

Figure 2.1: Removing the chassis top cover

2.2 Installing the Backplane or Motherboard

The ACP-4362 / 4360 supports either: up to 15-slot backplane, or ATX motherboard. To install the backplane or motherboard, please proceed as follows:

Note: *Use caution when installing a motherboard. It's highly recommended to integrate Advantech motherboard series with ACP-4362 / 4360 chassis to ensure the quality, safety and the air flow design.*

1. Dismantle the hold-down clamp by removing the two screws on both ends.
2. A yellow label is located inside of the chassis bottom. (*see Figure 2.2*) It shows the copper stub locations for attaching the specific backplane or motherboard. Users can find the copper stubs in the accessory box. Be sure to follow the instructions and fasten the backplane or motherboard onto the chassis according to the correct stub locations.
3. While installing a BACKPLANE, fasten it in place and attach the supplied EMI spring shielding with the screws provided. (*see Figure 2.3*)
4. For the PICMG 1.0 BACKPLANE, connect the orange-white wire from connector “HCN1” on the backplane to connector “CN21” on the CPU card.
5. While installing a MOTHERBOARD, attach the motherboard I/O shielding onto the rear plate first. Then fasten the motherboard onto the chassis. (*see Figure 2.4*)
6. Connect the 20-pin (or 24-pin) ATX power connector and the 4-pin +12V power connector from the power supply to the backplane or the motherboard.
7. Connect the 9-pin USB wire, Power switch wire, and the System Reset switch wire from the chassis to the motherboard.
8. Connect the wire of LAN LED from the chassis to the motherboard. Connect the wire of HDD LED from the SATA HDD backplane to the motherboard.

NUT NUMBER		1	2	3	4	5	6	7	8	9	10	11	12	13	14	15	16	17	18	19	20	21	22	23	24	25	26	27	28	29	X	A	M		
BP/MP MODEL																																			
PCA-6113P4R		*	*	*	*	*		*	*	*	*	*	*	*	*				*	*	*	*													
PCA-6114P7		*	*	*	*	*		*	*	*	*	*	*	*	*				*	*	*	*													
PCA-6114P4		*	*	*	*	*		*	*	*	*	*	*	*	*				*	*	*	*													
PCA-6114P10		*	*	*	*	*		*	*	*	*	*	*	*	*				*	*	*	*													
PCA-6114-B		*	*	*	*	*		*	*	*	*	*	*	*	*				*	*	*	*													
PCA-6113P7X		*	*	*	*	*		*	*	*	*	*	*	*	*				*	*	*	*												*	
PCA-6115		*	*	*	*	*		*	*	*	*	*	*	*	*				*	*	*	*													
PCA-6114P12X		*	*	*	*	*		*	*	*	*	*	*	*	*				*	*	*	*												*	
PCE-7B13-64		*	*	*	*	*		*	*	*	*	*	*	*	*				*	*	*	*													
PCE-5B12-64		*	*	*	*	*		*	*	*	*	*	*	*	*				*	*	*	*													
AIMB-740		*	*	*				*	*	*	*	*	*	*	*																				
AIMB-742		*	*	*				*	*	*	*	*	*	*	*																				
AIMB-744		*	*	*				*	*	*	*	*	*	*	*																				
AIMB-750		*	*	*				*	*	*	*	*	*	*	*				*	*	*	*													
AIMB-760		*	*	*				*	*	*	*	*	*	*	*				*	*	*	*													
AIMB-762		*	*	*				*	*	*	*	*	*	*	*				*	*	*	*													
AIMB-764		*	*	*				*	*	*	*	*	*	*	*				*	*	*	*													
AIMB-542																																			
AIMB-554																																			
AIMB-556			*	*				*	*	*	*	*	*	*	*				*	*	*	*													*
AIMB-560			*	*				*	*	*	*	*	*	*	*				*	*	*	*													*
AIMB-562			*	*				*	*	*	*	*	*	*	*				*	*	*	*													*

Be careful to screw the Copper Stub under 10 kgf·cm.

Figure 2.2: Yellow label indicating copper stub locations

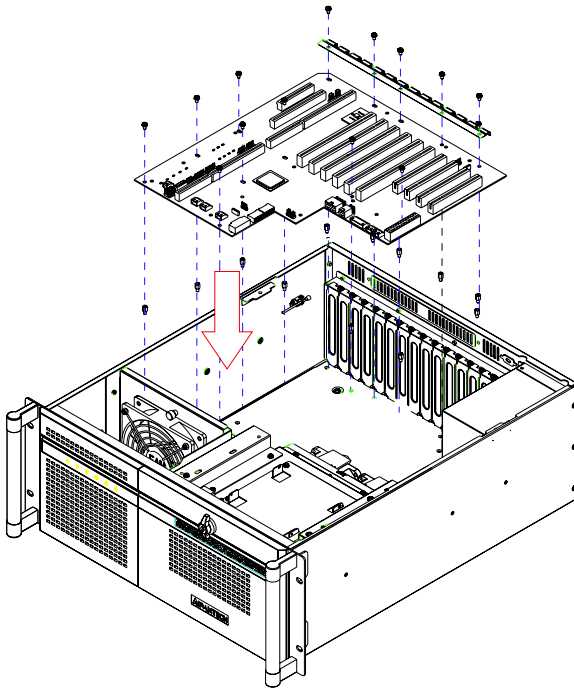

Figure 2.3: Installing the backplane

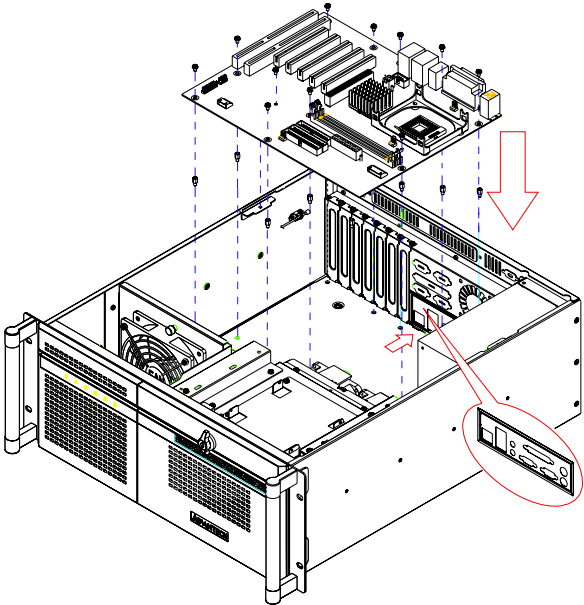

Figure 2.4: Installing a motherboard

2.3 Installing CPU Card or Add-on Card

ACP-4362 / 4360 supports up to 15 cards. To install a CPU card or add-on card, please proceed as follows:

1. Select a vacant PICMG slot for the full-length CPU card, or a PCI/ISA slot for other add-on cards. Then, remove the corresponding I/O bracket attached to the rear plate of the chassis.
2. Insert the CPU card (with CPU, CPU cooler, RAM, and necessary cables installed) or add-on card vertically into the proper slot. For full-length CPU card, please make sure that the card bracket has been inserted properly and the other edge of the card has been inserted into the plastic guiding fillister. Fasten the screws on the top of both brackets of the card. (see *Figure 2.5*).
3. Repeat Step 1 and 2 if there is more than one add-on card to be installed.
4. Connect the 9-pin USB wire, Power switch wire, and the System Reset switch wire from the chassis to the CPU card.
5. Connect the wire of LAN LED from the chassis to the CPU card. Connect the wire of HDD LED from the SATA HDD backplane to the CPU card.
6. For the PICMG 1.0 BACKPLANE, connect the orange-white wire from the connector “CN20” on the CPU card to connector “HCN1” on the backplane. Connect the power switch wire from the chassis to connector “CN21” on the CPU card.

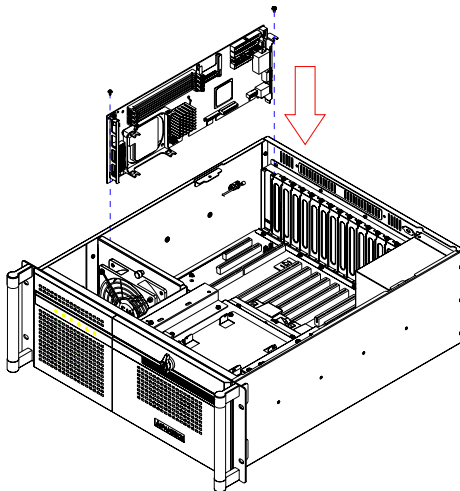

Figure 2.5: Installing a full-length card

2.4 Hold-down clamp

The hold-down clamp protects all the cards from vibration and shock. After installing all the cards, please refer to the following steps to install the rubber cushions and the hold-down clamp.

1. There are two rows of notches on both sides of the hold-down clamp for inserting into rubber cushions provided in the accessory box. One side is for PCI cards, while the other side is for ISA cards. Depending on the card height, the cushions can be inserted upward or downward. After the rubber cushions have been inserted into the notches, they will stabilize the add-on cards to protect them from shock and vibration. (see *Figure 2.6*)
2. Secure the hold-down clamp into its original position.

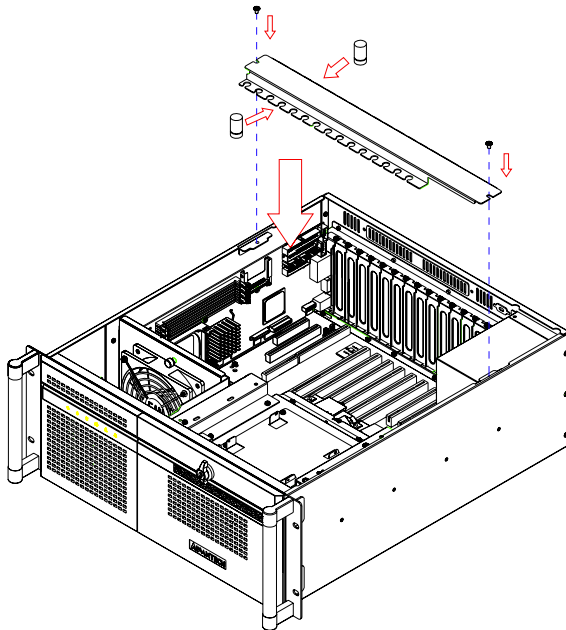

Figure 2.6: Installing rubber cushions and hold-down clamp

2.5 Installing Disk Drives

The APC-4362 / 4360 supports one slim-type optical disk drive, one 3.5" FDD (or internal HDD) and the mobile storage devices for six SATA HDDs. Please refer to the following instructions to install the various disk drives.

2.5.1 Installing HDD or FDD or Slim-type Optical Disk Drive

To install the 3.5" FDD (or internal HDD) or the slim-type optical disk drive, please follow these steps for installation.

1. To install the 3.5" FDD or internal HDD, simply release the two screws on top of the disk drive bracket. Then remove the front cover as well if you want to install the FDD.
2. Insert the disk drive into the proper location in the bracket and secure them with the screws provided. (see *Figure 2.7*)
3. Return the bracket with the disk drive in the original position and fasten it with the screws.

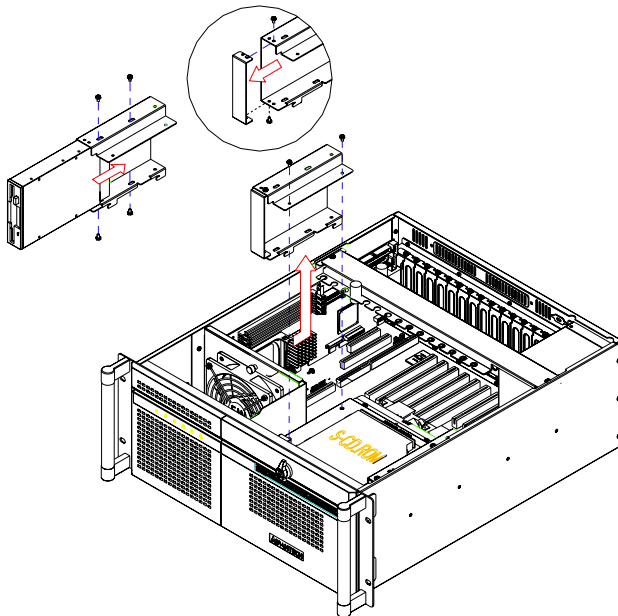

Figure 2.7: Installing 3.5" HDD or FDD

4. To install the slim-type optical disk drive, please connect the small converter (see Figure 2.8) provided in the accessory box to the rear of the optical disk drive and fasten it by the two screws provided.
5. Undo the screws on the slim-type optical disk drive bracket and its front cover. Then fix the optical disk drive to the bracket with the four screws provided. (see Figure 2.9)
6. Return the bracket with the slim-type optical disk drive in the original position and fasten it with the screws.
7. Connect a 40-pin IDE flat cable from the CPU card or the motherboard to the 3.5" internal HDD or the slim-type optical disk drive, or a 34-pin flat cable to a FDD. Then plug the power connector into each disk drive

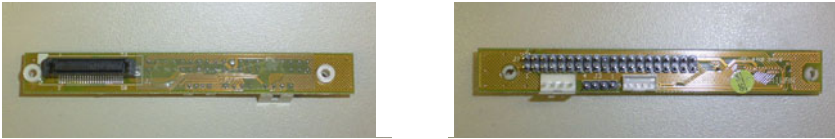

Figure 2.8: Converter for slim-type optical disk drive

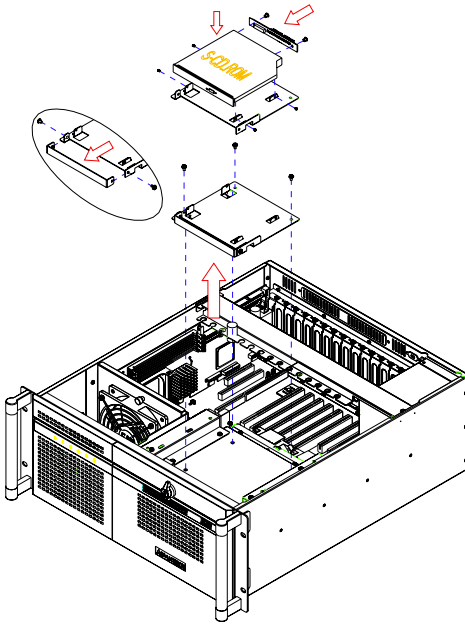

Figure 2.9: Installing the slim-type optical disk drive

2.5.2 Installing SATA HDD

ACP-4362 / 4360 supports either SATA or SATA II HDD. Please follow the installation procedures below to install the SATA HDD into the mobile HDD tray.

1. Open the front door by turning the rotary lock.
2. Push up the latch on the mobile tray to unlock it.
3. Press down the handle of the mobile tray and pull it out as far as it will go. Then completely take out the tray. (See Figure 2.10)
4. Fix a 3.5" SATA HDD to the proper location in the tray by fastening the screws provided. (Refer to Figure 2.11)
5. Return the mobile tray with SATA HDD and push it in by the handle until it is locked into the original position.
6. Push down the latch to lock the tray in place.
7. Repeat Steps 1 to 6 if there is more than one SATA HDD needs to be installed.

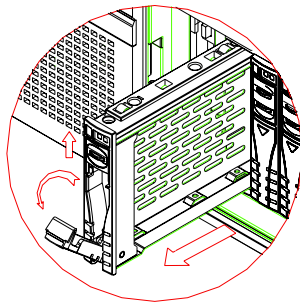

Figure 2.10: Pushing up the latch & removing the mobile tray

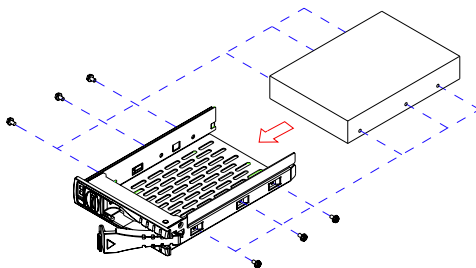

Figure 2.11: Installing a SATA HDD

2.6 Attaching the Ears and Handles

There are a pair of ears and handles in the accessory box. If you need to install the chassis on the rack, refer to Figure 2.12 to fasten them to the front-right and front-left edges with the four screws provided.

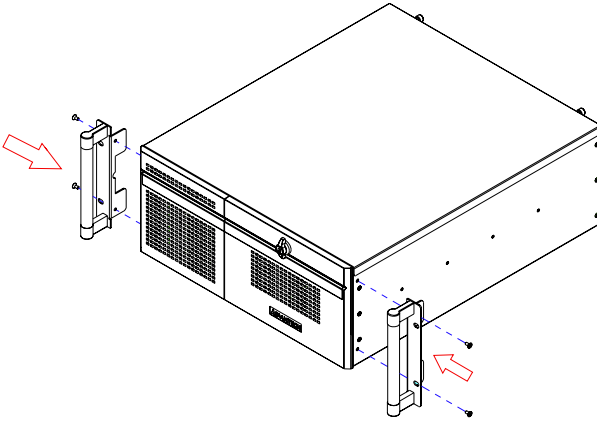

Figure 2.12: Attaching the ears and handles

CHAPTER

3

Operation

Chapter 3 Operation

3.1 The Front Panel

The front panel features the lockable door and six LED indicators. The user can close the door with or without the key with the user-friendly rotary lock. When opening the door, there is a momentary power switch, a System Reset button, an Alarm Reset button, and a dual USB port. Their individual functions are described as below.

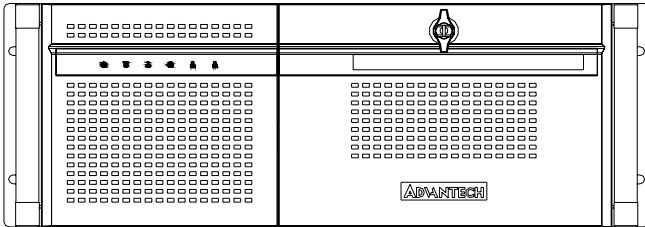

Figure 3.1: Closed front panel

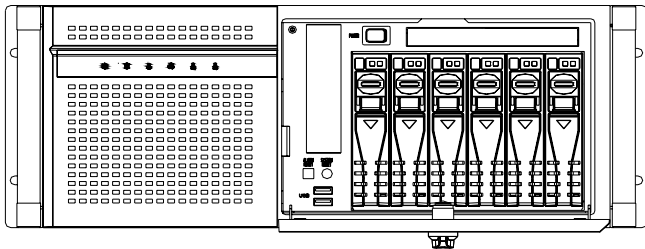

Figure 3.2: Open front panel

3.1.1 Switch, Buttons and I/O Interfaces

Momentary Power switch: Press this switch to turn the system power on or off. Please use system shutdown or press this switch for few seconds to turn off the system ATX power.

System Reset button: Press this button to reboot the system.





Alarm Reset button: Whenever a fault occurs in the system (e.g., fan failure or the chassis is overheated), the audible alarm will be activated. Pressing this button will stop the alarm from beeping.

Dual USB ports: For connecting a wide range of USB devices for data transfer, backup or input.

3.1.2 LED indicators for System Status

Six LEDs are placed on the left side of the front panel to indicate system health and activity. Please refer to Table 3.1 for the LED definition summary.

Table 3.1: LED Indicator functions

LED	Description	Green	Red
Power 	System Power	Normal	Abnormal
Fan 	Cooling Fan status	Normal	Abnormal
Temperature 	Temperature in the Chassis	Normal	Abnormal
Hard Disk 	Hard Disk Drive Activity	Data access	No light
LAN 	LAN1 & LAN2 status	Normal	No light
	Data transmit through LAN	Blinking	

When the system power is on, the power LED is always **Green**.

When the power LED is **RED**, it indicates a redundant power supply module failure. To stop the alarm beep, press the **Alarm Reset** button. Examine the redundant power supply module right away and replace the failed module with a working one.

When the fan LED is **RED**, it indicates a failed cooling fan, and the alarm is also activated. To stop the alarm beep, press the **Alarm Reset** button and then replace the failed fan with a working one immediately.

If the temperature LED is **RED**, the inside of the chassis is overheated (more than 50°C). An audible alarm will be activated. To stop the alarm beep, press the **Alarm Reset** button. Inspect the fan filter and the rear section of the chassis immediately. Make sure the airflow inside the chassis is smooth and not blocked by dust or other particles.

If the LAN1/LAN2 LED stays **GREEN**, it means the network connection works normally. When the data is transmitting through network, the LAN LED turns into blinking. When the LAN1/LAN2 LED fails to light up, inspect the LAN cable and the connection.

Note: AIMB-744 doesn't support the front LAN LED function.

3.1.3 LED Indicators for SATA HDD Power & Status

Each SATA HDD tray has a pair of LED indicators for displaying the SATA HDD power and the activity status. Please refer to Table 3.2 for the LED definition summary. For the alternative model, ACP-4360, the HDD failure and data rebuild status are not indicated while using the 3rdparty's SATA RAID card. (see Table 3.3)

Table 3.2: SATA HDD LED indicator functions for ACP-4362





LED	Description	Green	Blue	Red	Blue & Red
	power of HDD	HDD power on	N/A	N/A	N/A
	Status of HDD	N/A	Data access	HDD failure	Data rebuild or construction

Table 3.3: SATA HDD LED indicator functions for ACP-4360

LED	Description	Green	Blue
	power of HDD	HDD power on	N/A
	Status of HDD	N/A	Data access

When the system power is on and the SATA HDD is connected well, the HDD power LED is **Green**. If it fails to light up, check if you connect the SATA HDD well. Or please ask the technician to inspect the related cables in the chassis.

When the SATA HDD is transmitting some data, the status LED is blinking **BLUE**. When the SATA HDD is failed or damaged, the LED is **RED**. When the data is rebuilt or constructed, the LED turns into blinking **BLUE** and **RED** concurrently. (The LED appears **PINK**.)

3.2 The Rear Panel

On the backplane version, the rear plate includes 15-slot I/O brackets and a reserved 9-pin D-SUB opening. (See *Figure 3.3*). For the motherboard version, the rear plate includes 7-slot I/O brackets, 5 reserved 9-pin D-SUB openings and an 68-pin SCSI opening. (See *Figure 3.4*)

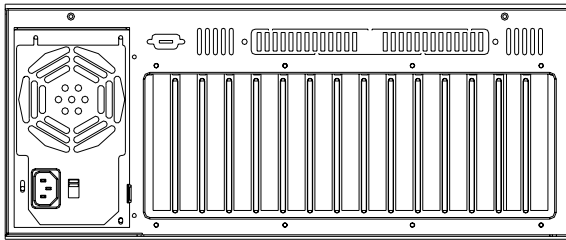

Figure 3.3: Rear panel of backplane version

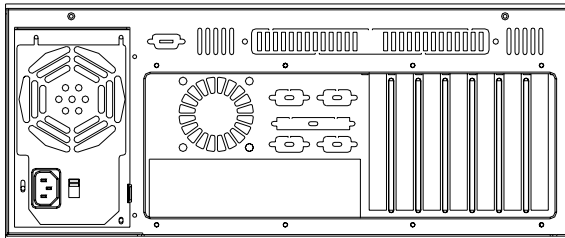

Figure 3.4: Rear panel of motherboard version

There is a ground screw with a washer located on the lower right of the rear panel. This will protect the system in case the electric leakage happens.

3.3 Replacing the Cooling Fan

There is one high-speed cooling fan behind the front panel and two fans behind the SATA HDD cage. All of these fans are easily maintained. The fans provide the system with ample cooling by blowing air toward the rear. Please proceed according to the instructions below.

3.3.1 Replacing the 12 cm fan

1. Remove the top cover.
2. Unplug the fan power connector.
3. Loosen the thumbscrew on top of the fan unit and then gently pull it out.
4. Loosen four screws on the fan bracket and the four screws on the fan guard and replace it with a new one.
5. Fix the new cooling fan on the bracket and fan guard by screwing in the eight screws. (see Figure 3.5)
6. Replace the fan unit into the chassis by tightening the thumbscrew and reconnect the fan power connector.
7. Replace the top cover and fasten it.

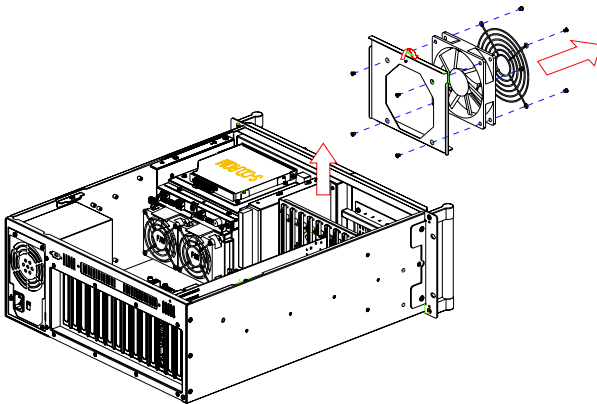

Figure 3.5: Replacing the cooling fan

3.3.2 Replacing the fan behind the SATA backplane

1. Remove the top cover.
2. Pull out the clip on top of the fan unit so that the fan detaches from the fan enclosure.
3. Unplug the fan power connector on the SATA HDD backplane. (see *Figure 3.6*)
4. Plug the power connector of the new fan into the SATA HDD backplane first.
5. Put a new fan into the fan enclosure carefully until it is locked by the tab. Be sure to install it securely in the enclosure.
6. Replace the top cover and fasten it.

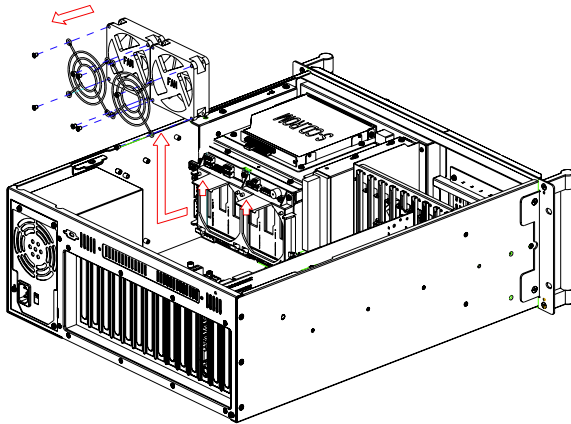

Figure 3.6: Replacing the fan behind the SATA HDD backplane

3.4 Cleaning the Filters

The filter functions to block dust or particles from the work environment and to extend the longevity of the system. It is recommended to clean the filters periodically. There are two reusable and washable filters behind the front door and the front of the fan. To remove and clean the filter, proceed as follows.

1. Open the front door.
2. Pull out the filter behind the front door by pushing the two clips; pull out the fan filter by pushing the hook and then slide it rightwards.
3. Clean the filter with a soft brush and wash the dust away from the filter with fluent water. Then dry it. (see *Figure 3.7*)
4. Replace the filter inside the unit.

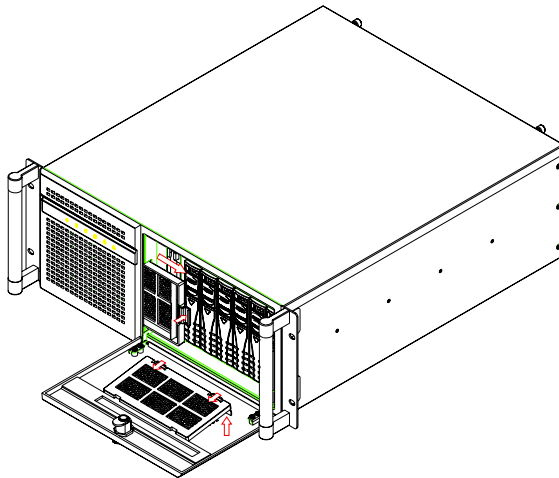

Figure 3.7: Replacing the filters

3.5 Replacing the Power Supply

The ACP-4362 / 4360 supports either a single PS/2, or a redundant power supply. To replace the power supply, please proceed as below.

3.5.1 Replacing the Single PS/2 Power Supply

1. Unplug the power cord from the power supply.
2. Remove the top cover and the hold-down clamp.
3. Unplug the 20-pin (or 24-pin) ATX power connector and 4-pin +12V power connector from the backplane/motherboard, as well as the power connectors from all disk drives.
4. Loosen the six screws on the power supply bracket and then gently pull it up (see Figure 3.8).
5. Replace the power supply with a new one and then fasten it onto the chassis.
6. Plug the 20-pin (or 24-pin) ATX power connector and 4-pin +12V power connector to the backplane/motherboard. Then plug other power connectors to the disk drives and peripherals.
7. Return the hold-down clamp and top cover. Then plug in the power cord.

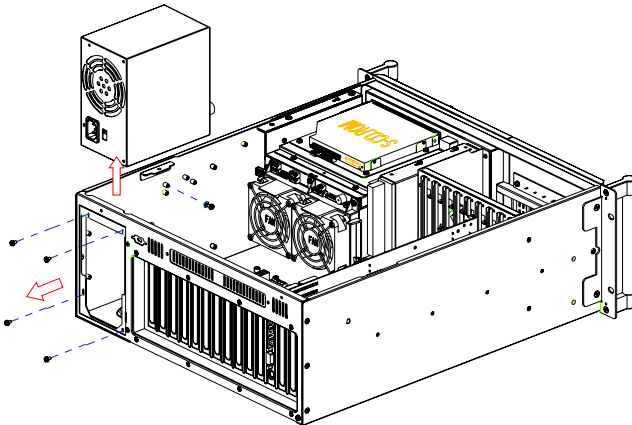

Figure 3.8: Replacing the single power supply

3.5.2 Replacing the Redundant Power Supply Module

1. Turn off the power switch of the failed power supply module.
2. Unplug the power cord from the failed module.
3. Loosen the screw on the failed module and then grab the handle to gently pull it out. (see *Figure 3.9*).
4. Make sure that the new power supply module is the same rating as the currently installed one.
5. Slide the power supply module inward until it locks into the right position.
6. Secure the screw and replace the handle. Then plug in the power cord.

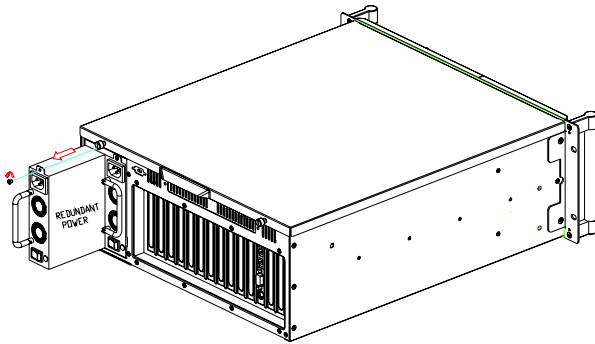

Figure 3.9: Replacing the power supply module

Note: *Note! When you plug two power cords into the same bank of sockets, please align them in the same direction (see *Figure 3.10*).*



Figure 3.10: Power cord plugs orientation on the socket

**SATA HDD Backplane,
Alarm and RAID
Application for
ACP-4362**

Chapter 4 SATA HDD Backplane, Alarm and RAID Application for ACP-4362

There is a SATA HDD backplane fixed behind the SATA storage device. It is more than interface for supporting six mobile SATA HDDs and the RAID card; it also provides system monitoring functions for thermal, fans, power and mobile SATA HDD through the audible alarm or the LED indicators. Please see the details below.

4.1 SATA HDD Backplane Layout

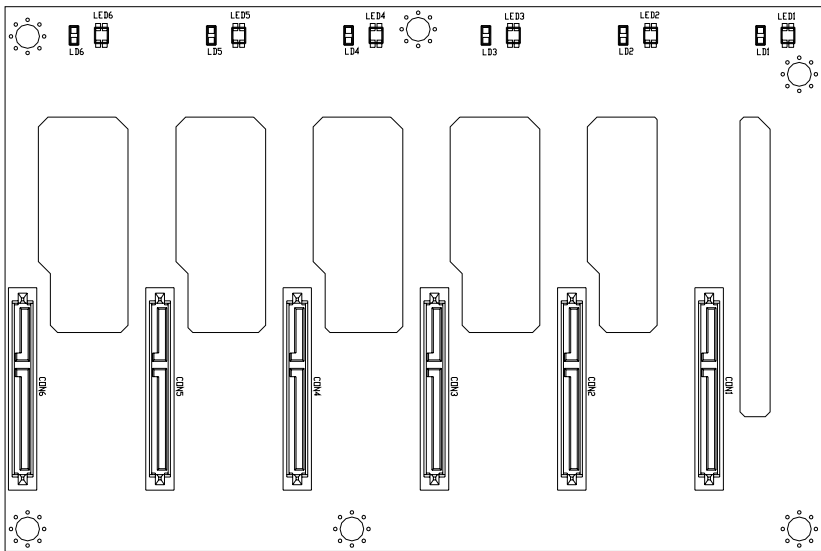

Figure 4.1: Front side layout of the SATA HDD backplane

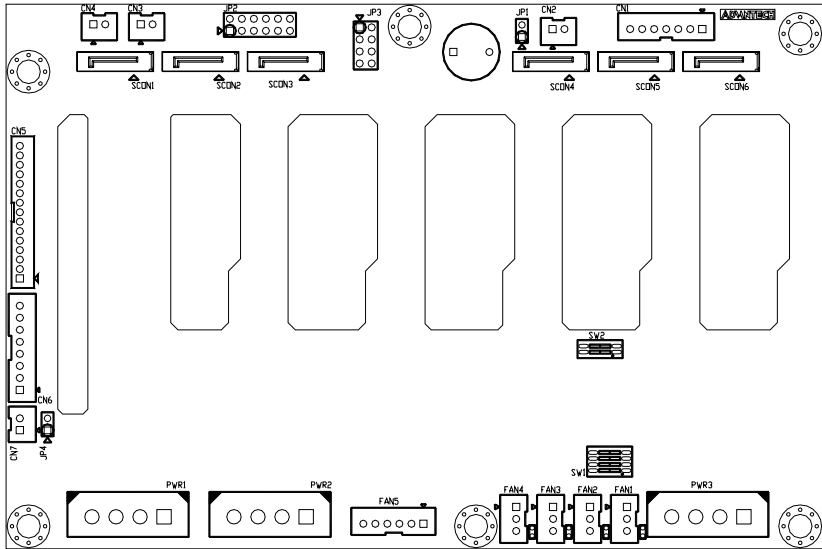

Figure 4.2: Back side layout of the SATA HDD backplane

4.2 SATA HDD Backplane Specifications

4.2.1 Connectors & Pin Definitions for SATA & RAID Related

Table 4.1: Mobile SATA HDD connectors and LEDs on front side

CON1 ~ CON6	SATA HDD connectors
LD1 ~ LD6	SATA HDD1 ~ HDD6 power LED (green)
LED1 ~ LED6	SATA HDD1 ~ HDD6 Bi-Color LED (blue/red) HDD Activity (Blue) HDD Fault (Red) Rebuild (Blink pink) No error: Off Blink (1/sec) Identify: Fast blink (~3/sec)

Table 4.2: SATA cable connectors on rear side

SCON1 ~ SCON6	SATA cable connectors for connecting to SATA RAID card
---------------	--

Table 4.3: PWR1~PWR3, Power connectors

Pin 1	+12V	Pin3	GND
Pin 2	GND	Pin4	VCC

Table 4.4: CN1, SATA RAID card connector (only for ACP-4362)

Pin 1	LED_DATA	Pin 5	GND
Pin 2	LED_CLK	Pin 6	A_SCL
Pin 3	GND	Pin 7	INT
Pin 4	A_SDA		

Table 4.5: JP2, Power and status LED connector for mobile SATA HDD (only for ACP-4362)

Pin 1	LED1	Pin 7	LED4
Pin 2	ACT_LED1	Pin 8	ACT_LED4
Pin 3	LED2	Pin 9	LED5
Pin 4	ACT_LED2	Pin 10	ACT_LED5
Pin 5	LED3	Pin 11	LED6
Pin 6	ACT_LED3	Pin 12	ACT_LED6

Table 4.6: JP3, Reserved firmware connector (only for ACP-4362)

Pin 1	VCC3	Pin 5	N/A
Pin 2	TDO	Pin 6	TMS
Pin 3	TDI	Pin 7	GND
Pin 4	N/A	Pin 8	TCK

4.2.2 Connectors & Pin Definition for Alarm Specifications

Table 4.7: CN2, Alarm reset connector (only for ACP-4362)

Pin 1	ALARM RESET	Pin 2	GND
-------	-------------	-------	-----

Table 4.8: CN3, Second thermal sensor connector (only for ACP-4362)

Pin 1	VTIN	Pin 2	A_G
-------	------	-------	-----

Table 4.9: CN4, Third thermal sensor connector

Pin 1	VTIN	Pin 2	A_G
-------	------	-------	-----

Table 4.10: CN5, Output connector to LED board (only for ACP-4362)

Pin 1	GND	Pin 9	Temperature Good
Pin 2	+5V signal	Pin 10	Temperature Fail
Pin 3	+12V signal	Pin 11	FAN Good
Pin 4	-5V signal	Pin 12	FAN Fail
Pin 5	-12V signal	Pin 13	N/A
Pin 6	HDD_1	Pin 14	+3.3V signal
Pin 7	Power Good	Pin 15	+5Vsb signal
Pin 8	Power Fail		

Table 4.11: CN6, Voltage detection input connector (only for ACP-4362)

Pin 1	+5Vsb	Pin 5	+5V
Pin 2	GND	Pin 6	+3.3V
Pin 3	GND	Pin 7	-12V
Pin 4	-5V	Pin 8	+12V

Table 4.12: CN7, Power fail input (only for ACP-4362)

Pin 1	GND	Pin 2	Power Fail
-------	-----	-------	------------

Table 4.13: JPI, Buzzer jumper (only for ACP-4362)

Pin 1	Buzzer	Pin 2	GND
-------	--------	-------	-----

Table 4.14: JP4, HDD LED connector (only for ACP-4362)

Pin 1	VCC	Pin 2	HLED_ACT
-------	-----	-------	----------

Table 4.15: FAN1~FAN4, Fan connectors (ACP-4360 only has FAN3 & FAN4)

Pin 1	GND	Pin3	FAN_DEC
Pin 2	+12V		

Table 4.16: FAN5, Reserved fan connector detecting speed of the 3rd to 7th fan

Pin 1	FAN_DEC3	Pin 4	FAN_DEC6
Pin 2	FAN_DEC4	Pin 5	FAN_DEC7
Pin 3	FAN_DEC5	Pin 6	GND

4.2.3 Jumper and Switch Settings

Users can set up to 3 thermal sensors, one onboard and two extra optional sensors. The ACP-4362 is configured with an optional thermal sensor near the left rear of the chassis. The default sensor number is 2.

(see Figure 4.3). Table 4.17 shows the sensor number setting. For setting the ACP-4360, refer to Chapter 5.

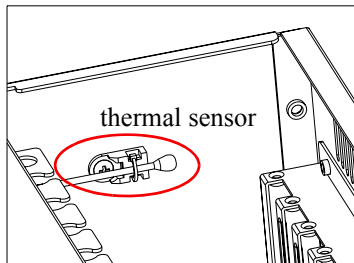

Figure 4.3: Thermal sensor location

Table 4.17: SW2, Thermal sensor number setting (only for ACP-4362)

Sensor Number	SW 2 -1	SW 2 - 2
0	ON	ON
1 (on board)	OFF	ON
2 (on board+CN3) (default)	ON	OFF
3 (on board+CN3+CN4)	OFF	OFF

Table 4.18: SW1, Fan number setting (only for ACP-4362)

Fan Number	SW 1-1	SW 1-2	SW 1-3	SW 1-4
0	ON	ON	ON	ON
1	OFF	ON	ON	ON
2	ON	OFF	ON	ON
3 (default)	OFF	OFF	ON	ON
4	ON	ON	OFF	ON
5	OFF	ON	OFF	ON
6	ON	OFF	OFF	ON
7	OFF	OFF	OFF	ON

Note: Connect the fan connectors in the correct sequence: if two fans are set on SW1, the correct method is to connect them into connectors FAN1 and FAN2. If the two fans are connected to other fan connectors, out of sequence, such as FAN1 and FAN3, or FAN2 and FAN3, or FAN3 and FAN4, instead of FAN1 and FAN2, then the alarm will not function correctly.

Table 4.19: JPI, Buzzer jumper (only for ACP-4362)

Enable (default)	OPEN
Disable	SHORT

4.3 SATA HDD Cage

It's not necessary to take out the SATA HDD cage while you install the SATA HDD or plug/unplug the wires and cables on it. If you do need to take it out, be careful to release all the relevant wires/cables and fans behind the SATA HDD cage, 3.5" disk drive and the slim-type optical disk drive, as well as the mobile trays. When in doubt, please consult with an experienced technician.

Note: Please be sure all the wires and cables have been plugged in well before you install any SATA HDD.

4.4 RAID Application

RAID stands for "Redundant Array of Independent/Inexpensive Disks." The ACP-4362 can be integrated with a SATA RAID card, like the Areca SATA RAID card to set up a Disk Array with hot swappable HDD functions. The alternative model, ACP-4360, does not indicate the data rebuild status, or if the HDD fails. However, ACP-4360 offers more flexible support for 3rd party SATA RAID cards.

When you install a SATA RAID card as a RAID system, please refer to the following steps.

1. Open the chassis top cover.
2. Insert the SATA RAID card into the vacant PCI-X or PCIe slot depending on the interface of the RAID card.
3. Find the provided cable in the accessory box and connect it from the add-on SATA RAID card (J5) to the SATA HDD backplane (CN1). (see Figure 4.4)
4. Connect the SATA cables from the SATA RAID card to the SATA HDD backplane so that the mobile SATA HDDs can execute the RAID applications and the hot swappable function.
5. Follow the detailed instructions for the SATA RAID card manual to implement your RAID system.

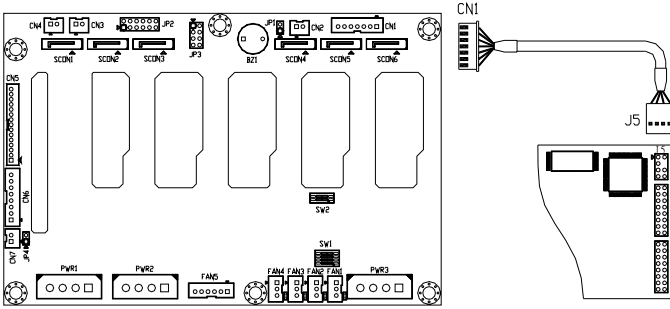

Figure 4.4: Connect the RAID card to SATA HDD backplane

Note: The SATA HDD backplane provides system detection and audible alarm functions, so be sure to disable the alert beep of the RAID card by changing the BIOS setting or through the RAID console application. Please check the detail of the RAID card manual.

CHAPTER

5

**Alarm Board for
ACP-4360**

Chapter 5 Alarm Board for ACP-4360

The alarm board is located under the system cooling fan. The alarm board makes an audible alarm when:

1. Any power supply module of the redundant power supply fails
2. One of the system cooling fans fails
3. The internal temperature of the chassis is too high

To stop the alarm beep, simply press the Alarm Reset button on the front panel and then take the necessary action to fix it.

5.1 Alarm Board Layout

The layout and detailed specification of the alarm board are given below:

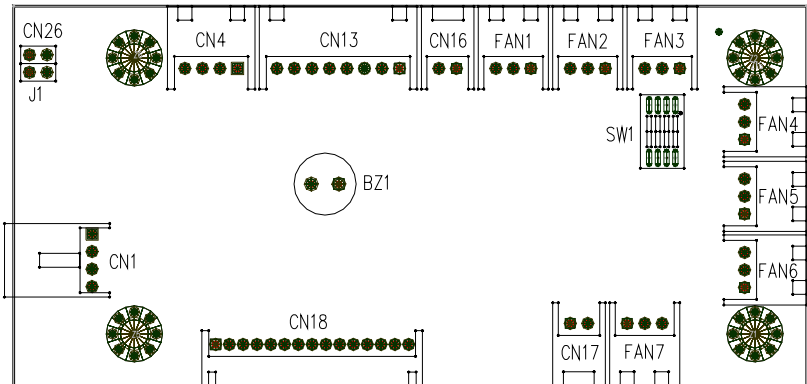

Figure 5.1: Alarm board layout

5.2 Alarm Board Specifications

Input Power: +5V, +12V

Input Signals:

- 7 fan connectors
- One “thermal sensor” connector (supports up to 8 thermal sensors in series)
- One “power good” input
- One “alarm reset” input
- One “voltage signal” connector (connect from the backplane, supporting six voltages: +12V, +5V, +3.3V, +5Vsb)
- One “hard disk LED” connector (connect from the CPU card or the motherboard)

Output Signals:

- One “LED board” connector
- One “buzzer” output

5.2.1 Connectors, Jumper and Pin Definition

Table 5.1: CN1, Auxiliary external power connector, standard mini 4-Pin power connector

Pin 1	+12V	Pin 3	GND
Pin 2	GND	Pin 4	+5V

Table 5.2: CN4, Thermal sensor (LM75) connector

Pin 1	+5V	Pin 3	T_SDAT
Pin 2	T_SCLK	Pin 4	GND

Table 5.3: CN13, Voltage detection input connector

Pin 1	+5Vsb	Pin 5	+5V
Pin 2	GND	Pin 6	+3.3V
Pin 3	GND	Pin 7	-12V
Pin 4	-5V	Pin 8	+12V

Table 5.4: CN16, Power good input connector

Pin 1	Power Good	Pin 2	GND
-------	------------	-------	-----

Table 5.5: CN17, Alarm reset connector

Pin 1	ALARM RESET	Pin 2	GND
-------	-------------	-------	-----

Table 5.6: CN18, Output connector to LED board

Pin 1	GND	Pin 9	Temperature Good
Pin 2	+5V signal	Pin 10	Temperature Fail
Pin 3	+12V signal	Pin 11	FAN Good
Pin 4	-5V signal	Pin 12	FAN Fail
Pin 5	-12V signal	Pin 13	N/A
Pin 6	HDD_1	Pin 14	+3.3Vsb signal
Pin 7	Power Good	Pin 15	+5Vsb signal
Pin 8	Power Fail		

Table 5.7: CN26, External HDD LED connector

Pin 1	HLED_ACT	Pin 2	N/A
-------	----------	-------	-----

Table 5.8: FAN1~FAN7, Fan connectors

Pin 1	GND	Pin3	FAN_DEC
-------	-----	------	---------

Table 5.8: FAN1~FAN7, Fan connectors

Pin 2	+12V		
-------	------	--	--

Table 5.9: J1, External buzzer

Pin 1	Buzzer	Pin 2	+5V
-------	--------	-------	-----

Table 5.10: SW1, Fan number select switch

Pin 1	GND	Pin 5	GND
Pin 2	FAN_SEL1	Pin 6	FAN_SEL3
Pin 3	GND	Pin 7	GND
Pin 4	FAN_SEL2	Pin 8	RESET

5.2.2 Switch Settings

The alarm board is designed to connect with up to 7 fans. User can set the fan number by adjusting the switch, SW1, on the alarm board.

Table 5.11: SW1, Fan number setting

Fan Number	SW 1-1	SW 1-2	SW 1-3	SW 1-4
0	OFF	OFF	OFF	OFF
1	ON	OFF	OFF	OFF
2	OFF	ON	OFF	OFF
3 (default)	ON	ON	OFF	OFF
4	OFF	OFF	ON	OFF
5	ON	OFF	ON	OFF
6	OFF	ON	ON	OFF
7	ON	ON	ON	OFF

Note: *Connect the fan connectors in the correct sequence: if two fans are set on SW1, the correct method is to connect them into connectors FAN1 and FAN2. If the two fans are connected to other fan connectors, out of sequence, such as FAN1 and FAN3 or FAN2 and FAN3 or FAN3 and FAN4, instead of FAN1 and FAN2, then the alarm will not function correctly.*

5.3 Thermal Sensor

The ACP-4360 is configured with a thermal sensor located at the rear plate of the chassis. (see Figure 5.2) Refer to Figure 5.3 for a diagram of the thermal sensor module layout.

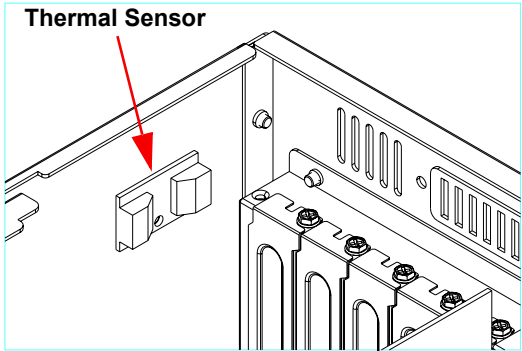

Figure 5.2: Thermal sensor location

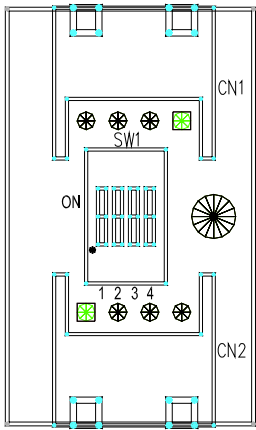

Figure 5.3: Thermal sensor module

Users can set up to 8 thermal sensors. The default sensor I.D. number is 1. Users can refer to Table 5.13 to set the sensor I.D. number by adjusting the switch, SW1, on the sensor module.

Table 5.12: CN1 & CN2, Temperature sensor connector

Pin 1	+5V	Pin 3	T_SDAT
Pin 2	T_SCLK	Pin 4	GND

Table 5.13: SW2, Thermal sensor I.D. number setting

Sensor I.D. No.	SW 1-1	SW 1-2	SW 1-3	SW 1-4
1 (default)	OFF	OFF	OFF	ON
2	OFF	OFF	ON	ON
3	OFF	ON	OFF	ON
4	OFF	ON	ON	ON
5	ON	OFF	OFF	ON
6	ON	OFF	ON	ON
7	ON	ON	OFF	ON
8	ON	ON	ON	ON

Appendix

A

Exploded Diagram and Parts List

Appendix A Exploded Diagram and Parts List

A.1 Exploded Diagram and Parts List

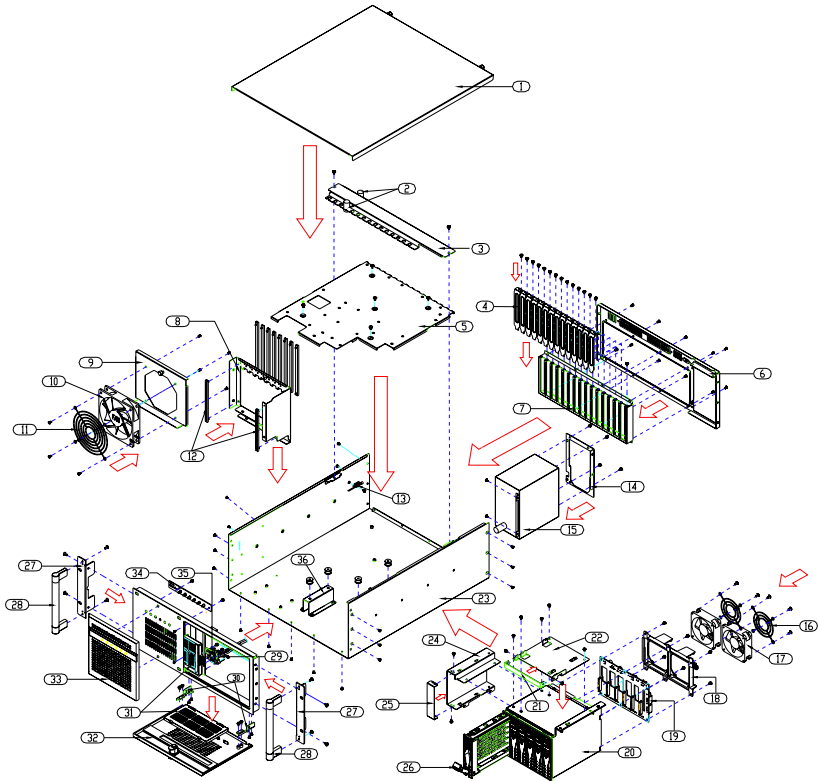

Figure A.1: Exploded diagram

Table A.1: Parts list

1	Top cover	13	Thermal sensor	25	FDD cover
2	Rubber cushion	14	Power supply bracket	26	Mobile HDD tray
3	Hold down clamp	15	Power supply	27	Rackmount ear
4	Adapter bracket	16	8cm fan guard	28	Handle
5	Under plate	17	8cm fan	29	USB port
6	Rear plate	18	Fan enclosure	30	Hinge
7	I/O bracket	19	SATA HDD backplane	31	Filter cover
8	Card guide bracket	20	Mobile HDD cage	32	Front door
9	Fan bracket	21	Slim CD-ROM cover	33	Left front panel
10	12cm fan	22	Slim CD-ROM bracket	34	LED board
11	12cm fan guard	23	Chassis body	35	Switch bracket
12	Guiding fillister	24	FDD bracket	36	Disk mounting bracket

Appendix

B

Backplane, Motherboard, and RAID Card Options

Appendix B Backplane, Motherboard, and RAID Card Options

B.1 Backplane Options

ACP-4362 supports a variety of backplanes. Users can contact a local sales representative for detailed specification and information.

Table B.1: PICMG 1.3 Backplane options

Model Name	Segment	Slots Per Segment				
		SHB*	PCIe x 16	PCIe x 8	PCI-X	PCI
PCE-7B13-64A1E	Single	1	-	2	6	4
PCE-5B12-64A1E	Single	1	1	-	6	4

*SHB: System Host Board

B.2 Motherboard Options

ACP-4362 supports a variety of Advantech ATX motherboards as below. Users can contact a local sales representative for detailed information.

Table B.2: ATX Motherboard options

Model Name	Bus				
	PCI	PCI/ISA	ISA	AGP	SATA
AIMB-744	2 (PCI-X 64-bit) 4 (PCI 32-bit)	-	-	1(8X)	2
AIMB-762	1 (PCIe 16X) 1 (PCIe 4X) 5 (PCI 32-bit)	-	-	-	4

B.3 SATA RAID Card Options

We carefully chose two SATA RAID cards which have been verified and compliant with ACP-4362. User can choose either of them as the RAID solution. Please contact a local sales representative for detailed information.

Table B.3: SATA RAID card options

Model Name	Interface
9680001857	PCI-X 8-port SATA RAID Card
9680001858	PCIe 8-port SATA RAID Card

B.4 Recommended Configurations

The following table details configurations recommended for a complete RAID system. Contact a local sales representative for detailed information.

Table B.4: Recommended configurations

Chassis Model	Backplane	SBC/MB	RAID Card
ACP-4362BP-40ZE ACP-4362BP-50ZE ACP-4362BP-40RE	PCE-5B12-64A1E	PCE-5120	9680001857 9680001858
ACP-4362BP-00XE & PS-700ATX-ZE	PCE-7B13-64A1E	PCE-7210	9680001857 9680001858
ACP-4362MB-40ZE ACP-4362MB-50ZE ACP-4362MB-40RE	-	AIMB-744	9680001857
ACP-4362MB-40ZE ACP-4362MB-50ZE ACP-4362MB-40RE	-	AIMB-762	9680001858

B.5 Backplane and Motherboard Options for ACP-4360

ACP-4360 can support various Advantech PICMG 1.3, or PICMG 1.0 14-slot backplanes, or the AIMB series of ATX motherboards. It also offers more flexible support for third party SATA RAID cards.