

User Manual

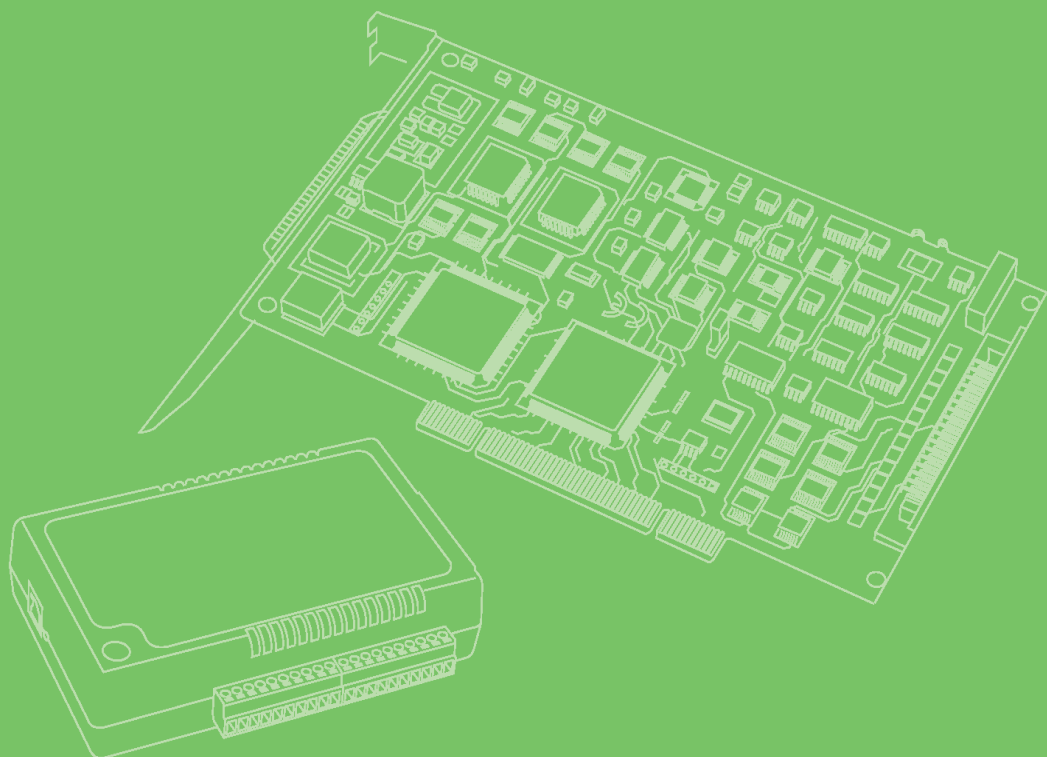

## PCL-841

2-port CAN-bus ISA Card with  
Isolation Protection

**ADVANTECH**  
eAutomation

---

## Copyright

The documentation and the software included with this product are copyrighted 2008 by Advantech Co., Ltd. All rights are reserved. Advantech Co., Ltd. reserves the right to make improvements in the products described in this manual at any time without notice. No part of this manual may be reproduced, copied, translated or transmitted in any form or by any means without the prior written permission of Advantech Co., Ltd. Information provided in this manual is intended to be accurate and reliable. However, Advantech Co., Ltd. assumes no responsibility for its use, nor for any infringements of the rights of third parties, which may result from its use.

## Acknowledgements

Intel and Pentium are trademarks of Intel Corporation.

Microsoft Windows and MS-DOS are registered trademarks of Microsoft Corp.

All other product names or trademarks are properties of their respective owners.

## Product Warranty (2 years)

Advantech warrants to you, the original purchaser, that each of its products will be free from defects in materials and workmanship for two years from the date of purchase.

This warranty does not apply to any products which have been repaired or altered by persons other than repair personnel authorized by Advantech, or which have been subject to misuse, abuse, accident or improper installation. Advantech assumes no liability under the terms of this warranty as a consequence of such events.

Because of Advantech's high quality-control standards and rigorous testing, most of our customers never need to use our repair service. If an Advantech product is defective, it will be repaired or replaced at no charge during the warranty period. For out-of-warranty repairs, you will be billed according to the cost of replacement materials, service time and freight. Please consult your dealer for more details.

If you think you have a defective product, follow these steps:

1. Collect all the information about the problem encountered. (For example, CPU speed, Advantech products used, other hardware and software used, etc.) Note anything abnormal and list any onscreen messages you get when the problem occurs.
2. Call your dealer and describe the problem. Please have your manual, product, and any helpful information readily available.
3. If your product is diagnosed as defective, obtain an RMA (return merchandise authorization) number from your dealer. This allows us to process your return more quickly.
4. Carefully pack the defective product, a fully-completed Repair and Replacement Order Card and a photocopy proof of purchase date (such as your sales receipt) in a shippable container. A product returned without proof of the purchase date is not eligible for warranty service.
5. Write the RMA number visibly on the outside of the package and ship it prepaid to your dealer.

# Declaration of Conformity

## CE

This product has passed the CE test for environmental specifications when shielded cables are used for external wiring. We recommend the use of shielded cables. This kind of cable is available from Advantech. Please contact your local supplier for ordering information.

## CE

This product has passed the CE test for environmental specifications. Test conditions for passing included the equipment being operated within an industrial enclosure. In order to protect the product from being damaged by ESD (Electrostatic Discharge) and EMI leakage, we strongly recommend the use of CE-compliant industrial enclosure products.

## FCC Class B

Note: This equipment has been tested and found to comply with the limits for a Class B digital device, pursuant to part 15 of the FCC Rules. These limits are designed to provide reasonable protection against harmful interference in a residential installation. This equipment generates, uses and can radiate radio frequency energy and, if not installed and used in accordance with the instructions, may cause harmful interference to radio communications. However, there is no guarantee that interference will not occur in a particular installation. If this equipment does cause harmful interference to radio or television reception, which can be determined by turning the equipment off and on, the user is encouraged to try to correct the interference by one or more of the following measures:

- Reorient or relocate the receiving antenna.
- Increase the separation between the equipment and receiver.
- Connect the equipment into an outlet on a circuit different from that to which the receiver is connected.
- Consult the dealer or an experienced radio/TV technician for help.

# Technical Support and Assistance

1. Visit the Advantech web site at [www.advantech.com/support](http://www.advantech.com/support) where you can find the latest information about the product.
2. Contact your distributor, sales representative, or Advantech's customer service center for technical support if you need additional assistance. Please have the following information ready before you call:
  - Product name and serial number
  - Description of your peripheral attachments
  - Description of your software (operating system, version, application software, etc.)
  - A complete description of the problem
  - The exact wording of any error messages

---

## Warnings, Cautions and Notes

**Warning!** Warnings indicate conditions, which if not observed, can cause personal injury!



**Caution!** Cautions are included to help you avoid damaging hardware or losing data. e.g.



*There is a danger of a new battery exploding if it is incorrectly installed. Do not attempt to recharge, force open, or heat the battery. Replace the battery only with the same or equivalent type recommended by the manufacturer. Discard used batteries according to the manufacturer's instructions.*

## Document Feedback

To assist us in making improvements to this manual, we would welcome comments and constructive criticism. Please send all such - in writing to: [support@advantech.com](mailto:support@advantech.com)

## Safety Instructions

1. Read these safety instructions carefully.
2. Keep this User Manual for later reference.
3. Disconnect this equipment from any AC outlet before cleaning. Use a damp cloth. Do not use liquid or spray detergents for cleaning.
4. For plug-in equipment, the power outlet socket must be located near the equipment and must be easily accessible.
5. Keep this equipment away from humidity.
6. Put this equipment on a reliable surface during installation. Dropping it or letting it fall may cause damage.
7. The openings on the enclosure are for air convection. Protect the equipment from overheating. **DO NOT COVER THE OPENINGS.**
8. Make sure the voltage of the power source is correct before connecting the equipment to the power outlet.
9. Position the power cord so that people cannot step on it. Do not place anything over the power cord.
10. All cautions and warnings on the equipment should be noted.
11. If the equipment is not used for a long time, disconnect it from the power source to avoid damage by transient overvoltage.
12. Never pour any liquid into an opening. This may cause fire or electrical shock.
13. Never open the equipment. For safety reasons, the equipment should be opened only by qualified service personnel.
14. If one of the following situations arises, get the equipment checked by service personnel:
  15. The power cord or plug is damaged.
  16. Liquid has penetrated into the equipment.
  17. The equipment has been exposed to moisture.

18. The equipment does not work well, or you cannot get it to work according to the user's manual.
19. The equipment has been dropped and damaged.
20. The equipment has obvious signs of breakage.
21. DO NOT LEAVE THIS EQUIPMENT IN AN ENVIRONMENT WHERE THE STORAGE TEMPERATURE MAY GO BELOW -20° C (-4° F) OR ABOVE 60° C (140° F). THIS COULD DAMAGE THE EQUIPMENT. THE EQUIPMENT SHOULD BE IN A CONTROLLED ENVIRONMENT.
22. CAUTION: DANGER OF EXPLOSION IF BATTERY IS INCORRECTLY REPLACED. REPLACE ONLY WITH THE SAME OR EQUIVALENT TYPE RECOMMENDED BY THE MANUFACTURER, DISCARD USED BATTERIES ACCORDING TO THE MANUFACTURER'S INSTRUCTIONS.
23. The sound pressure level at the operator's position according to IEC 704-1:1982 is no more than 70 dB (A).

## Safety Precaution - Static Electricity

DISCLAIMER: This set of instructions is given according to IEC 704-1. Advantech disclaims all responsibility for the accuracy of any statements contained herein.

**Safety Precaution - Static Electricity**  
Follow these simple precautions to protect yourself from harm and the products from damage.

- To avoid electrical shock, always disconnect the power from your PC chassis before you work on it. Don't touch any components on the CPU card or other cards while the PC is on.
- Disconnect power before making any configuration changes. The sudden rush of power as you connect a jumper or install a card may damage sensitive electronic components.



# Contents

|                   |   |           |
|-------------------|---|-----------|
| <b>Chapter 1</b>  | <b>Overview .....</b>                                     | <b>1</b>  |
| 1.1               | Introduction .....  | 2         |
| 1.2               | Features .....  | 2         |
| 1.3               | Specifications .....                                      | 3         |
| 1.4               | Block Diagram .....                                       | 4         |
| 1.5               | Initial Inspection .....                                  | 5         |
| <b>Chapter 2</b>  | <b>Hardware Installation .....</b>                        | <b>7</b>  |
| 2.1               | Initial Inspection .....                                  | 8         |
| 2.2               | Jumper and Switch Locations .....                         | 8         |
| 2.3               | Card Configuration .....                                  | 9         |
|                   | Table 2.1: Switch and jumper functions.....               | 9         |
|                   | Table 2.2: Memory address configuration (SW1) .....       | 9         |
|                   | Table 2.3: Memory address configuration (SW1) cont'd..... | 10        |
| <b>Chapter 3</b>  | <b>Software Overview .....</b>                            | <b>11</b> |
| 3.1               | Software Overview .....                                   | 12        |
| 3.1.1             | Main Menu .....   | 12        |
| 3.1.2             | Configuration.....  | 13        |
| 3.1.3             | Terminal.....   | 15        |
| <b>Chapter 4</b>  | <b>Wiring .....</b>                                       | <b>17</b> |
| 4.1               | Pin Assignments .....                                     | 18        |
|                   | Figure 4.1 CAN Termination Resistor Installation.....     | 18        |
| 4.2               | CAN Signal Wiring .....                                   | 19        |
|                   | Figure 4.2 CAN Wiring Topology .....                      | 19        |
| <b>Appendix A</b> | <b>Register Structure .....</b>                           | <b>21</b> |
| A.1               | CAN Controller Address Allocation .....                   | 22        |
| A.1.1             | Philips PCX82C200 CAN Controller .....                    | 22        |
| A.1.2             | Register Address Map .....                                | 23        |



# Chapter 1

Overview

---

## 1.1 Introduction

The PCL-841 is a special purpose communication card that brings the Control Area Network to your PC. With the built-in CAN controller, the PCL-841 provides bus arbitration and error detection with automatic transmission repeat function. This drastically avoids data loss and ensures system reliability. The on-board CAN controllers are located at different positions in the memory. You can run both CAN controllers at the same time, independently. The PCL-841 operates at baud rates up to 1 Mbps and can be installed directly into the expansion slot of your PC.

### **Control Area Network**

The CAN (Control Area Network) is a serial bus system especially suited for networking "intelligent" I/O devices as well as sensors and actuators within a machine or plant. Characterized by its multi-master protocol, real-time capability, error correction, high noise immunity, and the existence of many different silicon components, the CAN serial bus system, originally developed by Bosch for use in automobiles, is increasingly being used in industrial automation.

### **Direct Memory Mapping**

The PCL-841 is assigned with memory address, which allows direct access to the CAN controller. This is the simplest and fastest way of programming any board in a PC because the board is regarded as standard RAM.

### **Optical Isolation Protection**

On-board optical isolators protect your PC and equipment against damage from ground loops, increasing system reliability in harsh environments.

## 1.2 Features

- Operates two separate CAN networks at the same time
- High speed transmission up to 1 Mbps
- 16 MHz CAN controller frequency
- Takes a 4 KB address space, 40 base address adjustable (C800H up to EF00H)
- Optical isolation protection of 1000 VDC ensures system reliability
- Wide IRQ selection for each port includes: IRQ 3, 4, 5, 6,7, 9, 10, 11, 12, 15
- LED indicates Transmit/Receive status on each port
- Direct memory mapping enables speedy access to the CAN controllers
- C library and examples included

## 1.3 Specifications

- Ports: 2
- CAN controller: 82C200
- CAN transceiver: 82C250
- Signal support: CAN-L, CAN-H
- Memory address: From C800H to EF00H
- IRQ: 3, 4, 5, 6, 7, 9, 10, 11, 12, 15
- Isolation voltage: 1000 VDC
- Power consumption: +5 V @ 400 mA typical, 950 mA max.
- Connectors: Dual DB-9 male connectors
- Operating temperature: 32 to 122oF (0 to 50oC)
- Dimensions: 7.25" x 4.13" (18.4 x 10.5 cm)
- Shipping weight: 0.9 lb (0.4 kg)

## 1.4 Block Diagram

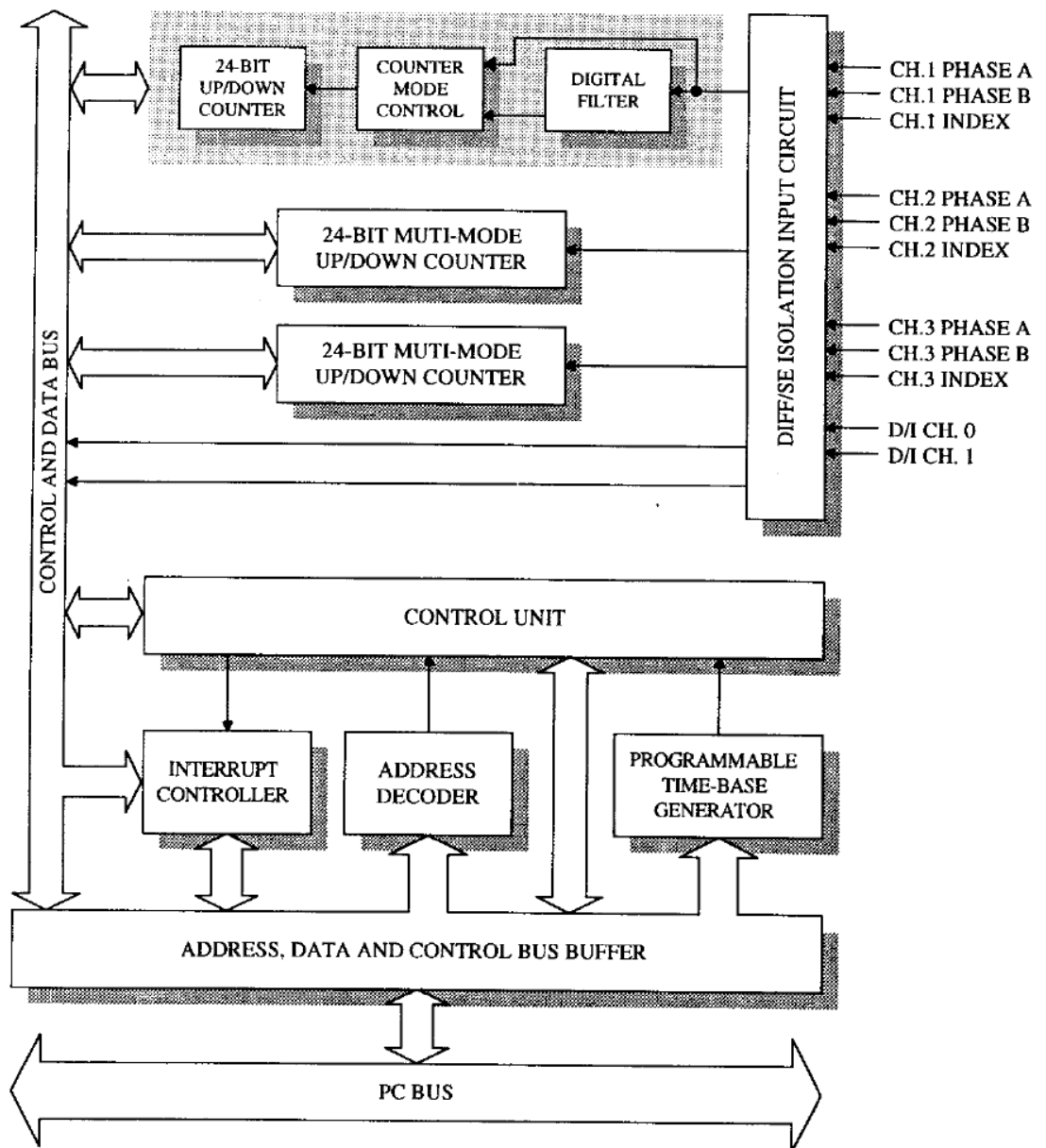

## 1.5 Initial Inspection

After receiving your PCL-841 package, please inspect its contents first. The package should contain the following items:

- PCL-841 encoder card
- Companion CD-ROM (DLL driver included)
- Startup user Manual

The PCL-841 card harbors certain electronic components vulnerable to electrostatic discharge (ESD). ESD could easily damage the integrated circuits and certain components if preventive measures are not carefully paid attention to. ***Before removing the module from the antistatic plastic bag, you should take following precautions to ward off possible ESD damage:***

- Touch the metal part of your computer chassis with your hand to discharge static electricity accumulated on your body. One can also use a grounding strap.
- Make contact between the antistatic bag and ground before opening.

### **After taking out the module, you should first:**

Inspect the module for any possible signs of external damage (loose or damaged components, etc.). If the module is visibly damaged, please notify our service department or our local sales representative immediately.

Avoid using a damaged module with your system.

- Avoid physical contact with materials that could hold static electricity such as plastic, vinyl and Styrofoam.



# Chapter 2

## Hardware Installation

## 2.1 Initial Inspection

You will find the following items inside the shipping package:

- PCL-841 Dual-port CAN Interface Card
- C Driver and DataMonitor Utility Diskette

We have carefully inspected the PCL-841 mechanically and electrically before shipping. It should be free of marks and scratches and in perfect working order upon receipt.

As you unpack the PCL-841, check it for signs of shipping damage (damaged box, scratches, dents, etc.). If it is damaged or it fails to meet specifications, notify our service department or your local representative immediately. Also notify the carrier. Retain the shipping carton and packing material for inspection by the carrier. After inspection we will make arrangements to repair or replace the unit.

When you handle the PCL-841, remove it from its protective packaging by grasping the rear metal panel. Keep the anti-vibration packing. Whenever you remove the card from the PC, store it in this package for protection.

## 2.2 Jumper and Switch Locations

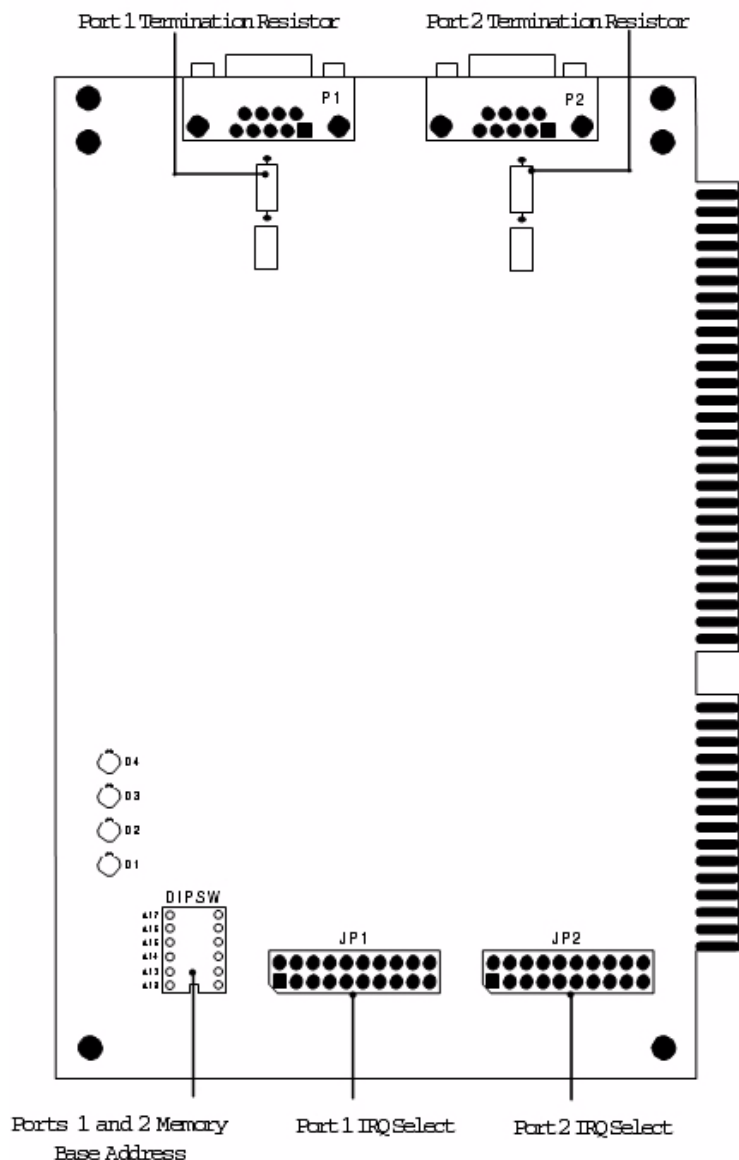

## 2.3 Card Configuration

The PCL-841 has two ports, each with one jumper. The jumpers set the IRQ for the ports, which can be configured separately. A DIP switch sets the memory base address for each port. The following chart shows the function of the jumper and the switch (see the previous page for jumper and switch locations).

**Table 2.1: Switch and jumper functions**

| CAN Controllers     |                |
|---------------------|----------------|
| JP1                 | Port 1         |
| JP2                 | Port 2         |
| Memory Base Address |                |
| SW1                 | Port 1, Port 2 |

### Default Settings

Port 1 is set for COM1 (IRQ=12, Memory address=DA00:0000).

Port 2 is set for COM2 (IRQ=15, Memory address=DA00:0200).

If you need to change these settings, see the following sections. Otherwise, you can simply install the card. Note that you will need to disable your CPU card's on-board COM ports, if any, or set them to alternate addresses/IRQs.

### Interrupt (IRQ) Setup (JP1 and JP2)

Jumpers JP1 and JP2 set the interrupts for Port 1 and Port 2, respectively. You can choose any IRQ from 3 to 15, except 8, 13 and 14. When you choose IRQs, make sure they are not used for other cards in the system. The following figures show the card's default settings.

JP1: Port 1 IRQ Default JP2: Port 2 IRQ Default

### Memory Base Address (SW1)

The memory base address for the PCL-841, which requires 4 KB of address space, is made up of the memory segment and its associated offset. The address for the memory segment is set through SW1, a six-position DIP switch. You can choose any base address from C800 to EF00. The following table shows the DIP switch settings and the corresponding base addresses.

**Table 2.2: Memory address configuration (SW1)**

| Address/DIP switch | A12 | A13 | A14 | A15 | A16 | A17 |
|--------------------|-----|-----|-----|-----|-----|-----|
| C800H              | on  | on  | on  | off | on  | on  |
| C900H              | off | on  | on  | off | on  | on  |
| CA00H              | on  | off | on  | off | on  | on  |
| CB00H              | off | off | on  | off | on  | on  |
| CC00H              | on  | on  | off | off | on  | on  |
| CD00H              | off | on  | off | off | on  | on  |
| CE00H              | on  | off | off | off | on  | on  |
| CF00H              | off | off | off | off | on  | on  |

**Table 2.3: Memory address configuration (SW1) cont'd**

| Address/DIP switch | A12 | A13 | A14 | A15 | A16 | A17 |
|--------------------|-----|-----|-----|-----|-----|-----|
| D000H              | on  | on  | on  | on  | off | on  |
| D100H              | off | on  | on  | on  | off | on  |
| D200H              | on  | off | on  | on  | off | on  |
| D300H              | off | off | on  | on  | off | on  |
| D400H              | on  | on  | off | on  | off | on  |
| D500H              | off | on  | off | on  | off | on  |
| D600H              | on  | off | off | on  | off | on  |
| D700H              | off | off | off | on  | off | on  |
| D800H              | on  | on  | on  | off | off | on  |
| D900H              | off | on  | on  | off | off | on  |
| DA00H              | on  | off | on  | off | off | on  |
| DB00H              | off | off | on  | off | off | on  |
| DC00H              | on  | on  | off | off | off | on  |
| DD00H              | off | on  | off | off | off | on  |
| DE00H              | on  | off | off | off | off | on  |
| DF00H              | off | off | off | off | off | on  |
| E000H              | on  | on  | on  | on  | on  | off |
| E100H              | off | on  | on  | on  | on  | off |
| E200H              | on  | off | on  | on  | on  | off |
| E300H              | off | off | on  | on  | on  | off |
| E400H              | on  | on  | off | on  | on  | off |
| E500H              | off | on  | off | on  | on  | off |
| E600H              | on  | off | off | on  | on  | off |
| E700H              | off | off | off | on  | on  | off |
| E800H              | on  | on  | on  | off | on  | off |
| E900H              | off | on  | on  | off | on  | off |
| EA00H              | on  | off | on  | off | on  | off |
| EB00H              | off | off | on  | off | on  | off |
| EC00H              | on  | on  | off | off | on  | off |
| ED00H              | off | on  | off | off | on  | off |
| EE00H              | on  | off | off | off | on  | off |
| EF00H              | off | off | off | off | on  | off |

**Memory Area**

Once the memory segment for the base address is selected, the offset will be automatically assigned for Port 1, Port 2, and hardware reset. The following table shows the base addresses of the CAN controllers.

| Base address (hex)      | CAN Controller          |
|-------------------------|-------------------------|
| base:0000h - base:00FFh | Basic- Port 1           |
| base:0100h - base:01FFh | HW reset Basic - Port 1 |
| base:0200h - base:02FFh | Basic- Port 2           |
| base:0300h - base:03FFh | HW reset Basic - Port 2 |
| base:0400h - base:0FFFh | Not used                |

# Chapter 3

## Software Overview

## 3.1 Software Overview

The PCL-841 comes with a utility disk with the following software capabilities:

- CAN controller configuration
- CAN transmission monitoring
- Terminal emulation

### 3.1.1 Main Menu

Run DataMonitor at the DOS prompt. DataMonitor's main menu screen will appear as shown below:



The main screen consists of:

- A. Menu bar: Lists the available functions. From the main menu you can select Configuration, Monitoring, and Terminal.
- B. Monitor screen: Shows monitored data, including message index, CAN device ID, data length, and data.
- C. Status fields: Display the status of the two ports and the status register of the CAN controllers.
- D. Online help/message bar: Shows various key commands and states the function of the currently highlighted item.

### 3.1.2 Configuration

Before you transmit a CAN object, you must configure the CAN controller by selecting the <Config> menu with the cursor keys and pressing <Enter>. The Configuration function determines the ports to be used and their communication parameters.



The parameters below need to be configured for each CAN controller:

**Address segment:** The base address (address segment) of the PCL-841 is normally adjusted during the installation process. The selection of the address segment needs to be the same as that of the hardware configuration.

**Port:** Select the port you want to configure.

**Baud rate:** The baud rate must be coordinated with the CAN network. Choose the appropriate one from the list of baud rates.

**Acceptance code:** Specifies the value of the 8 most significant bits of the identifier (ID10 ... ID 3)

**Acceptance mask:** Specifies the bit positions which are "relevant" for filtering.

**Note:** The acceptance code and acceptance mask are configured through eight digits (1 digit per bit) using 0 or 1.

| Value | Definition   |
|-------|--|
| 0     | This bit position will accept only a "relevant" message. |
| 1     | This bit position will not screen messages.              |

Example: Acc Code = 11111111

Acc Mask =11111111

The shown acceptance filter will accept every received message.

Interrupt: Sets the interrupt for each port. Be sure that this setting matches the IRQ already selected for the PCL-841, which accepts values between IRQ3 to IRQ15, except 8 and 13.

Running mode: During the normal configuration and communication process, select Normal Mode. When the system fails, you can hit <Enter> to reset the CAN controller. Hit <Enter> again to return to Normal Mode to further execute your configuration.

### Monitor

Select the port to be monitored from the <Monitor> pull-down menu. Press F3 to start and stop the monitoring process.

### Monitor Screen

The monitored data for a selected port appears in the monitor screen (see area B in the diagram under Main Menu section.)

If the CAN controller is configured correctly and the transmission has been successfully completed, every CAN object will be shown in order of appearance.

### Status Fields

Status fields at the right of the screen display the status of the two ports:

```
Port1
PORT1 Mode :NORMAL
State      :00001100
Accept code:00000000
Accept mask:11111111
BT0       :03
BT1       :1C
Out control:11111010
```

```
Port2
PORT2 Mode :NORMAL
State      :00001100
Accept code:00000000
Accept mask:11111111
BT0       :03
BT1       :1C
Out control:11111010
```

The status fields show information including the Mode (Normal or Reset), Acceptance Code, Acceptance Mask, BTR0, BTR1, Output Control Register, and Status Register. The normal value of the Status Register is:

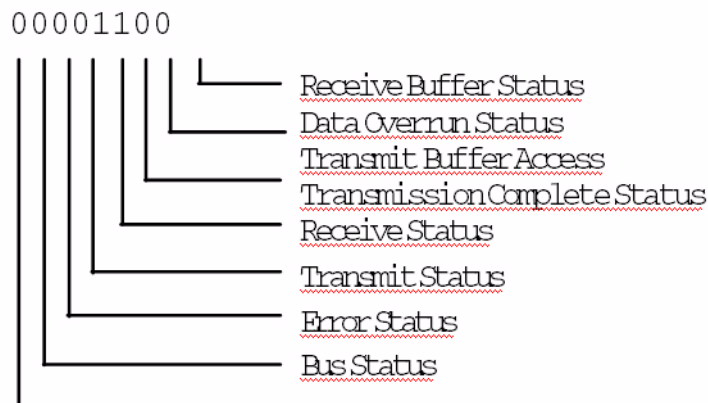

The registers can only be read if the CAN controller is in Normal mode. If the CAN controller operates correctly and the transmission has been completed successfully, the status register will show as the normal value: 00001100. If the Error Status and/or the Bus Status is 1, you have selected the wrong baud rate or the CAN cable is damaged. Also check the correct bus terminator.

### 3.1.3 Terminal

This function provides a direct way to:

1. Send data over the CAN network.
2. Test CAN transmission.

Select <Terminal> from the menu bar for the following screen:



---

### **Transmitting Data**

To transmit data, the PCL-841 must be connected to a CAN network with at least one node and the configuration for the card must be complete.

First, select <Terminal> to edit the data. Enter the port, the object ID and the data bytes as hexadecimal value. Press <Enter> to begin data transmission. If the CAN controller is configured correctly and the transmission has been successfully completed, every CAN object will be shown in order of appearance at the left side of the screen.

### **Testing Data Transmission**

To test CAN transmission without actually sending, connect Port 1 to Port 2 on the PCL-841. Select <Terminal> and enter port 1 as transmitting port. Port 2 will therefore be designated as receiving port.

Note: To send Data Frame (Transmit), enter "0" for RTR. If you want to send Remote Frame (Request), enter "1" for RTR.

# Chapter 4

Wiring

## 4.1 Pin Assignments

The following figure shows the pin assignments for the card's DB-9 connectors.

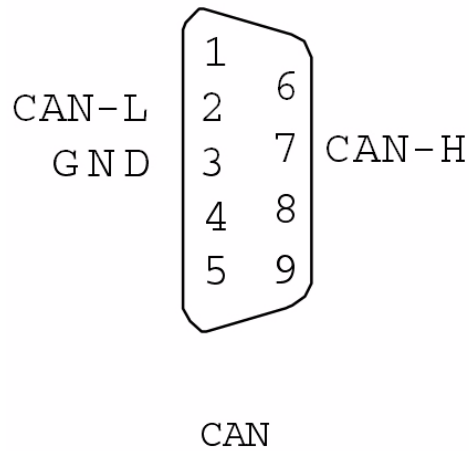

### Termination Resistor Setup

Terminal resistors are factory installed to allow for impedance matching. These resistors can be enabled by utilizing jumpers number 9 and 10 (shown below). Jumper 9 enables the terminal resistor for port one, while jumper number 10 enables the terminal resistor for port two. The value of the resistor should equal the characteristic impedance of the signal wires (approximately 120  $\Omega$ ).

The following figure shows resistor placements.

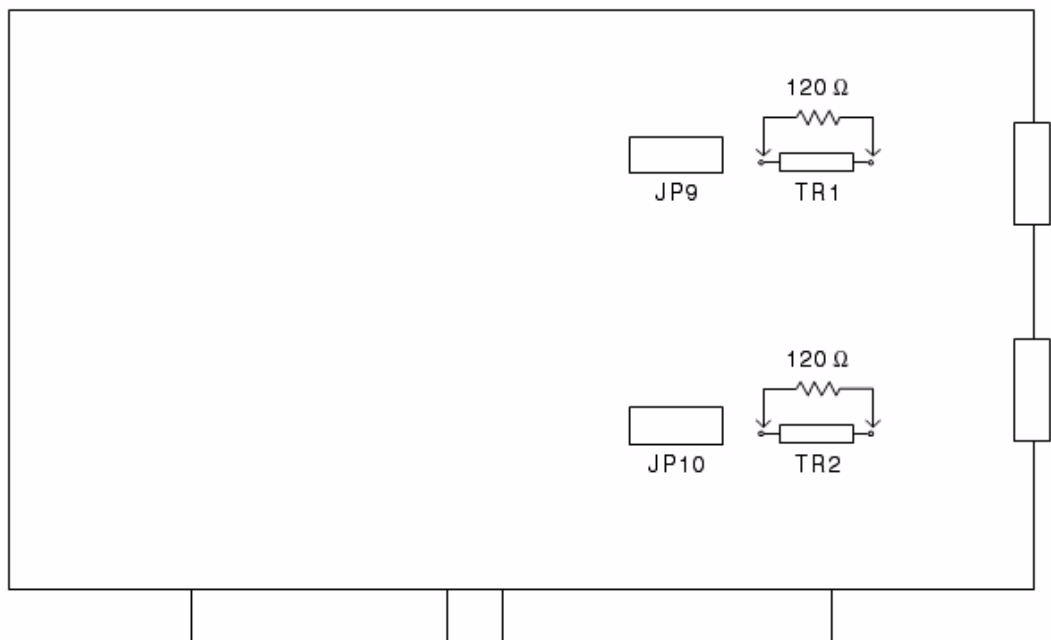

**Figure 4.1 CAN Termination Resistor Installation**

## 4.2 CAN Signal Wiring

The CAN standard supports half-duplex communication. This means that just two wires are used to transmit and receive data.

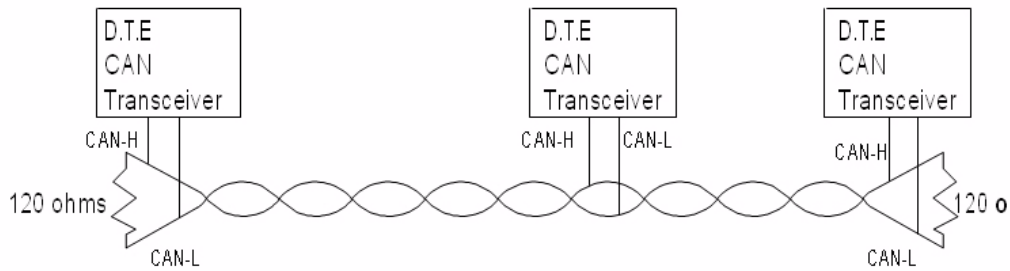

**Figure 4.2 CAN Wiring Topology**

Wiring connections are as follows:

| <b>PCL-841 DTE (male DB-9) Terminal DTE</b> |        |        |
|---|--------|--------|
| Pin   | Signal | Signal |
| 7   | CAN-H  | CAN-H  |
| 3   | GND    | GND    |
| 2   | CAN-L  | CAN-L  |



# Appendix **A**

## Register Structure

# A.1 CAN Controller Address Allocation

## A.1.1 Philips PCX82C200 CAN Controller

ADDRESS

|   |                 |
|---|-----------------|
| 0 | CONTROL         |
| 1 | COMMAND         |
| 2 | STATUS          |
| 3 | INTERRUPT       |
| 4 | ACCEPTANCE CODE |
| 5 | ACCEPTANCE MASK |
| 6 | BUS TIMING 0    |
| 7 | BUS TIMING 1    |
| 8 | OUTPUT CONTROL  |
| 9 | TEST            |

} control segment

|    |                           |
|----|---------------------------|
| 10 | IDENTIFIER                |
| 11 | RTR.BIT, DATA LENGTH CODE |
| 12 | BYTE 1                    |
| 13 | BYTE 2                    |
| 14 | BYTE 3                    |
| 15 | BYTE 4                    |
| 16 | BYTE 5                    |
| 17 | BYTE 6                    |
| 18 | BYTE 7                    |
| 19 | BYTE 8                    |

} descriptor

} data field } transmit buffer

|    |                           |
|----|---------------------------|
| 20 | IDENTIFIER                |
| 21 | RTR.BIT, DATA LENGTH CODE |
| 22 | BYTE 1                    |
| 23 | BYTE 2                    |
| 24 | BYTE 3                    |
| 25 | BYTE 4                    |
| 26 | BYTE 5                    |
| 27 | BYTE 6                    |
| 28 | BYTE 7                    |
| 29 | BYTE 8                    |

receive buffers

## A.1.2 Register Address Map

| #                         | TITLE                    | ADDR  | 7          | 6            | 5                     | 4                        | 3                            | 2                         | 1                        | 0                     |
|---------------------------|--------------------------|-------|------------|--------------|-----------------------|--------------------------|------------------------------|---------------------------|--------------------------|-----------------------|
| <b>Control Segment</b>    |                          |       |            |              |                       |                          |                              |                           |                          |                       |
| 1                         | Control Register         | 0     | Test Mode  | Sync         | Reserved              | Overrun Interrupt Enable | Error Interrupt Enable       | Transmit Interrupt Enable | Receive Interrupt Enable | Reset Request         |
| 2                         | Command Register         | 1     | Reserved   | Reserved     | Reserved              | Goto Sleep               | Clear Overrun Status         | Release Receive Buffer    | Abort Transmission       | Transmission Request  |
| 3                         | Status Register          | 2     | Bus Status | Error Status | Transmit Status       | Receive Status           | Transmission Complete Status | Transmit Buffer Access    | Data Overrun             | Receive Buffer Status |
| 4                         | Interrupt Register       | 3     | Reserved   | Reserved     | Reserved              | Wake-Up Interrupt        | Overrun Interrupt            | Error Interrupt           | Transmit Interrupt       | Receive Interrupt     |
| 5                         | Acceptance Code Register | 4     | AC.7       | AC.6         | AC.5                  | AC.4                     | AC.3                         | AC.2                      | AC.1                     | AC.0                  |
| 6                         | Acceptance Mask Register | 5     | AM.7       | AM.6         | AM.5                  | AM.4                     | AM.3                         | AM.2                      | AM.1                     | AM.0                  |
| 7                         | Bus Timing Register 0    | 6     | SJW.1      | SJW.0        | BRP.5                 | BRP.4                    | BRP.3                        | BRP.2                     | BRP.1                    | BRP.0                 |
| 8                         | Bus Timing Register 1    | 7     | SAM        | TSEG2.2      | TSEG2.1               | TSEG2.0                  | TSEG1.3                      | TSEG1.2                   | TSEG1.1                  | TSEG1.0               |
| 9                         | Output Control Register  | 8     | OCTP1      | OCTN1        | OCPOL1                | OCTP0                    | OCTN0                        | OCPOL0                    | OCMODE1                  | OCMODE0               |
| 10                        | Test Register (note 1)   | 9     | Reserved   | Reserved     | Map Internal Register | Connect RX Buffer 0 CPU  | Connect TX Buffer CPU        | Access Internal Bus       | Normal RAM Connct        | Float Output Driver   |
| <b>Transmit Buffer</b>    |                          |       |            |              |                       |                          |                              |                           |                          |                       |
| 11                        | Identifier               | 10    | ID.10      | ID.9         | ID.8                  | ID.7                     | ID.6                         | ID.5                      | ID.4                     | ID.3                  |
|                           | RTR, Data Length Code    | 11    | ID.2       | ID.1         | ID.0                  | RTR                      | DLC.3                        | DLC.2                     | DLC.1                    | DLC.0                 |
|                           | Bytes 1-8                | 12-19 | Data       | Data         | Data                  | Data                     | Data                         | Data                      | Data                     | Data                  |
| <b>Receive Buffer 0/1</b> |                          |       |            |              |                       |                          |                              |                           |                          |                       |
| 12                        | Identifier               | 20    | ID.10      | ID.9         | ID.8                  | ID.7                     | ID.6                         | ID.5                      | ID.4                     | ID.3                  |
|                           | RTR, Data Length Code    | 21    | ID.2       | ID.1         | ID.0                  | RTR                      | DLC.3                        | DLC.2                     | DLC.1                    | DLC.0                 |
|                           | Bytes 1-8                | 22-29 | Data       | Data         | Data                  | Data                     | Data                         | Data                      | Data                     | Data                  |





# ADVANTECH

## *eAutomation*

[www.advantech.com](http://www.advantech.com)

Please verify specifications before quoting. This guide is intended for reference purposes only.

All product specifications are subject to change without notice.

No part of this publication may be reproduced in any form or by any means, electronic, photocopying, recording or otherwise, without prior written permission of the publisher.

All brand and product names are trademarks or registered trademarks of their respective companies.

© Advantech Co., Ltd. 2007