



CE EMC

TEST REPORT

For

Softlogic Digital Controller

Model: BAS-2520

Trade Name: ADVANTECH

Issued for

Advantech Co., Ltd.

**No. 1, Alley 20, Lane 26, Rueiguang Road, Neihu District,
Taipei 114, Taiwan, R.O.C.**

Issued by

Compliance Certification Services Inc.

No. 81-1, Lane 210, Bade Rd., 2, Luchu Hsiang,

Taoyuan Hsien, (338) Taiwan, R.O.C.

TEL: 886-3-324-0332

FAX: 886-3-324-5235



Note: This report shall not be reproduced except in full, without the written approval of Compliance Certification Services Inc. Ltd. This document may be altered or revised by Compliance Certification Services Inc. personnel only, and shall be noted in the revision section of the document.



TABLE OF CONTENTS

1	TEST RESULT CERTIFICATION	3
2	EUT DESCRIPTION.....	4
3	TEST METHODOLOGY.....	5
3.1	EUT SYSTEM OPERATION.....	5
3.2	DECISION OF FINAL TEST MODE.....	5
4	SETUP OF EQUIPMENT UNDER TEST.....	6
5	FACILITIES AND ACCREDITATIONS.....	6
5.1	FACILITIES.....	6
5.2	LABORATORY ACCREDITATIONS AND LISTINGS	7
6	INSTRUMENT AND CALIBRATION.....	8
6.1	MEASURING INSTRUMENT CALIBRATION.....	8
6.2	TEST AND MEASUREMENT EQUIPMENT	8
7	LINE CONDUCTED & RADIATED EMISSION TEST.....	10
7.1	LIMIT	10
7.2	TEST PROCEDURE OF LINE CONDUCTED EMISSION.....	11
7.3	TEST PROCEDURE OF COMMON MODE CONDUCTED EMISSION FOR TELECOMMUNICATION PORT	12
7.4	TEST PROCEDURE OF RADIATED EMISSION.....	13
7.5	TEST RESULTS	15
8	POWER HARMONICS TEST.....	18
9	POWER VOLTAGE FLUCTUATION / FLICKER TEST	20
10	ELECTROSTATIC DISCHARGE (ESD) IMMUNITY TEST	22
11	RADIATED ELECTROMAGNETIC FIELD IMMUNITY TEST	26
12	FAST TRANSIENTS/BURST IMMUNITY TEST.....	29
13	SURGE IMMUNITY TEST.....	31
14	CONDUCTED DISTRBANCE/INDUCED RADIO-FREQUENCY FIELD IMMUNITY TEST ...	33
15	POWER FREQUENCY MAGNETIC FIELD IMMUNITY TEST.....	35
16	VOLTAGE DIPS / SHORT INTERRUPTIONS	37
	APPENDIX I - PHOTOGRAPHS OF TEST SETUP	38



1 TEST RESULT CERTIFICATION

Applicant: Advantech Co., Ltd.
No. 1, Alley 20, Lane 26, Rueiguang Road, Neihu District,
Taipei 114, Taiwan, R.O.C.

Manufacturer: Advantech Co., Ltd.
No. 1, Alley 20, Lane 26, Rueiguang Road, Neihu District,
Taipei 114, Taiwan, R.O.C.

Equipment Under Test: Softlogic Digital Controller

Trade Name: ADVANTECH

Model: BAS-2520

Detailed EUT Description: See Item 2 of this report

Date of Test: July 13, 2004

Applicable Standard	Class/Limit/Criterion	Test Result
EN 55022: 1998	Class A	No non-compliance noted
EN 61000-3-2: 2000	Class A/B/C/D	N/A
EN 61000-3-3: 1995 + A1: 2001	Limit	N/A
EN 55024: 1998, including		
IEC 61000-4-2: 1995 + A2: 2000	Criterion B	No non-compliance noted
IEC 61000-4-3: 1995 + A2: 2000	Criterion A	No non-compliance noted
IEC 61000-4-4: 1995 + A1: 2000	Criterion B	No non-compliance noted
IEC 61000-4-5: 1995 + A1: 2000	Criterion B	No non-compliance noted
IEC 61000-4-6: 1996 + A1: 2000	Criterion A	No non-compliance noted
IEC 61000-4-8: 1993 + A1: 2000	Criterion A	No non-compliance noted
IEC 61000-4-11: 1994 + A1: 2000	Criterion B/C/C	N/A
Deviation from Applicable Standard		
According to applicant's declaration this EUT is a class A product, and to be market in industrial environment only.		

The above equipment was tested by Compliance Certification Services Inc. for compliance with the requirements set forth in the EMC Directive 89/336/EEC and the technical standards mentioned above. The results of testing in this report apply only to the product/system, which was tested. Other similar equipment will not necessarily produce the same results due to production tolerance and measurement uncertainties.

Approved by:

Kurt Chen
Director of Linkou Laboratory
Compliance Certification Services Inc.

Reviewed by:

Jessie Wang
Section Manager of Linkou Laboratory
Compliance Certification Services Inc.



2 EUT DESCRIPTION

Product	Softlogic Digital Controller
Trade Name	ADVANTECH
Model	BAS-2520
Housing Type	Metal Case
EUT Power Rating	24VAC

I/O Port of EUT

I/O Port Type	Q'TY	TESTED WITH
1). DIO Port	2	2
2). RS232 Port	1	1
3). RS485 Port	1	1
4). IDE Port	1	1



3 TEST METHODOLOGY

3.1 EUT SYSTEM OPERATION

1. The EUT connected with I-Port Serial Device to Ethernet Gateway and power adapter (Customer Consigns).
2. The EUT connected with I/O Expansion Module be terminal during all testing.

3.2 DECISION OF FINAL TEST MODE

1. The following test mode was scanned during the preliminary test:

Mode 1

Data transmit control

2. After the preliminary scan, the following test mode was found to produce the highest emission level.

Mode 1

Then, the EUT configuration and cable configuration of the above highest emission mode was chosen for all final test items.



4 SETUP OF EQUIPMENT UNDER TEST

Setup Diagram

See test photographs attached in Appendix 1 for the actual connections between EUT and support equipment.

Support Equipment

No.	Equipment	Model No.	Serial No.	FCC ID	Trade Name	Data Cable	Power Cord
1	I/O Expansion Module	BAS-2020	N/A	FCC DoC	ADVANTECH	IDE Cable: Unshielded, 0.5m DIO Cable: Unshielded, 1.8m x 2	N/A
2	I-Port Serial Device to Ethernet Gateway	ADAM-4577	N/A	FCC DoC	ADVANTECH	RS-232 Cable: Unshielded, 1.8m	Unshielded, 1.8m
3	Power Adapter	N/A	N/A	N/A	N/A	N/A	AC I/P: Unshielded, 1.8m AC O/P: Unshielded, 1m
4	DIO Cable	N/A	N/A	N/A	N/A	Unshielded, 1.8m x 3 with one core	N/A
5	RS-485 Cable	N/A	N/A	N/A	N/A	Unshielded, 0.15m	N/A

Note: All the above equipment/cables were placed in worse case positions to maximize emission signals during emission test.

Grounding: Grounding was in accordance with the manufacturer's requirements and conditions for the intended use.

5 FACILITIES AND ACCREDITATIONS







5.1 FACILITIES

All measurement facilities used to collect the measurement data are located at CCS Taiwan Linkou Lab at No. 81-1, Lane 210, Bade Rd., 2, Luchu Hsiang, Taoyuan Hsien, Taiwan.

The measurement facilities are constructed in conformance with the requirements of CISPR 16-1, ANSI C63.4 and other equivalent standards.

5.2 LABORATORY ACCREDITATIONS AND LISTINGS

The test facilities used to perform Electromagnetic compatibility tests are registered or accredited by the organizations listed in the following table which includes the recognized scope specifically.

Country	Agency	Scope of Accreditation	Logo
USA	NVLAP	EN 55011, EN 55014-1, AS/NZS 1044, CNS 13783-1, EN 55022, CNS 13438, EN 61000-3-2, EN 61000-3-3, ANSI C63.4, FCC OST/MP-5, AS/NZS CISPR 22, IEC 61000-4-2, IEC 61000-4-3, IEC 61000-4-4, IEC 61000-4-5, IEC 61000-4-6, IEC 61000-4-8, IEC 61000-4-11	 Lab. Code 200650-0
USA	FCC	3/10 meter Open Area Test Sites to perform FCC Part 15/18 measurements	 93105, 90471
Japan	VCCI	3/10 meter Open Area Test Sites and conducted test sites to perform radiated/conducted measurements	 R-393/1066/725/879/1868 C-402/747/912
Norway	NEMKO	EN 50081-1/2, EN 50082-1/2, IEC 61000-6-1/2, EN 50091-2, EN 50130-4, EN 55011, EN 55013, EN 55014-1/2, EN 55015, EN 55022, EN 55024, EN 61000-3-2/3, EN 61326-1, IEC 61000-4-2/3/4/5/6/8/11, EN 60601-1-2, EN 300 328-2, EN 300 422-2, EN 301 419-1, EN 301 489-01/03/07/08/09/17, EN 301 419-2/3, EN 300 454-2, EN 301 357-2	 ELA 124a ELA 124b ELA 124c
Taiwan	CNLA	EN 300 328-1, EN 300 328-2, EN 300 220-1, EN 300 220-2, EN 300 220-3, 47 CFR FCC Part 15 Subpart C, EN 61000-3-2, EN 61000-3-3, CNS 13439, CNS 13783-1, CNS 14115, CNS 13438, AS/NZS CISPR 22, CNS 13022-1, IEC 61000-4-2/3/4/5/6/8/11, CNS 13022-2/3	 0 3 6 3 ILAC MRA
Taiwan	BSMI	CNS 13438, CNS 13783-1, CNS 13439, CNS 14115	 SL2-IS-E-0014 / IN-E-0014 /A1-E-0014 /R1-E-0014 /R2-E-0014 /L1-E-0014
Canada	Industry Canada	RSS212, Issue 1	 IC 3991-3 IC 3991-4

Note: No part of this report may be used to claim or imply product endorsement by CNLA, NVLAP or other government agency.



6 INSTRUMENT AND CALIBRATION

6.1 MEASURING INSTRUMENT CALIBRATION

The measuring equipment utilized to perform the tests documented in this report has been calibrated once a year or in accordance with the manufacturer's recommendations, and is traceable under the IEC 17025 to international or national standards. Equipment has been calibrated by accredited calibration laboratories.

6.2 TEST AND MEASUREMENT EQUIPMENT

The following list contains measurement equipment used for testing. The equipment conforms to the requirement of CISPR 16-1, ANSI C63.2 and other required standards.

Calibration of all test and measurement, including any accessories that may effect such calibration, is checked frequently to ensure the accuracy. Adjustments are made and correction factors are applied in accordance with the instructions contained in the respective manual.

Equipment Used for Emission Measurement

Open Area Test Site # 1				
Name of Equipment	Manufacturer	Model	Serial Number	Calibration Due
Spectrum Analyzer	ADVANTEST	R3261C	71720533	N.C.R
EMI Test Receiver	R&S	ESVS10	834468/006	04/16/2005
Pre-Amplifier	Anritsu	MH648A	M18767	08/31/2004
Bilog Antenna	CHASE	CBL6112A	2309	01/30/2005
Turn Table	EMCO	2081-1.21	N/A	N.C.R
Antenna Tower	EMCO	2075-2	9707-2604	N.C.R
Controller	EMCO	2090	N/A	N.C.R
RF Switch	Anritsu	MP59B	M54367	N.C.R
Site NSA	C&C	N/A	N/A	08/15/2004

Note: The measurement uncertainty is less than +/- 3.36dB, which is evaluated as per the NAMAS NIS 81 and CISPR/A/291/CDV.

**Equipment Used for Immunity Measurement**

ESD Test Site (IEC/EN 61000-4-2)				
Name of Equipment	Manufacturer	Model	Serial Number	Calibration Due
ESD Generator	SCHAFFNER	NSG438	170	04/19/2005

Radiated Electromagnetic Field Immunity Test Site (IEC/EN 61000-4-3)				
Name of Equipment	Manufacturer	Model	Serial Number	Calibration Due
S.G.	R&S	SMY02	100094	08/05/2004
Power Meter	R&S	NRVD	837794/029	N.C.R.
Power Sensor	R&S	URV5-Z2	835640/015	N.C.R.
Power Sensor	R&S	URV5-Z2	835640/016	N.C.R.
Power Amplifier	ar	150W1000	300300	N.C.R
Power Antenna	EMCO	93141	9712-1083	N.C.R

Fast Transients/Burst Test Site (IEC/EN 61000-4-4)				
Name of Equipment	Manufacturer	Model	Serial Number	Calibration Due
Fast Transients/Burst Generator	HAEFELY TRENCH	PEFT- JUNIOR	583 333-117	08/19/2004

Surge Immunity Test Site (IEC/EN 61000-4-5)				
Name of Equipment	Manufacturer	Model	Serial Number	Calibration Due
Surge Tester	HAEFELY TRENCH	PSUGER 4010	583 334-71	08/19/2004

CS Test Site (61000-4-6)				
Name of Equipment	Manufacturer	Model	Serial Number	Calibration Due
S.G.	R&S	SMY02	100094	08/05/2004
Power Meter	R&S	NRVD	837794/029	N.C.R.
Power Sensor	R&S	URV5-Z2	835640/015	N.C.R.
Power Sensor	R&S	URV5-Z2	835640/016	N.C.R.
Power Amplifier	ar	500A100A	300299	N.C.R
CDN	Lüthi	801-M3	1879	03/03/2005
CDN	MEB	M2	A3002010	04/27/2005

Power Frequency Magnetic Field Immunity Test Site (IEC/EN 61000-4-8)				
Name of Equipment	Manufacturer	Model	Serial Number	Calibration Due
TRIAX ELF Magnetic Field Meter	F.W.BELL	4090	9711	11/13/2004
Magnetic Field Tester	HAEFELY TRENCH	MAG 100.1	080 938-01	N.C.R



7 LINE CONDUCTED & RADIATED EMISSION TEST

7.1 LIMIT

Maximum permissible level of Line Conducted Emission

Frequency (MHZ)	Class A (dBuV)		Class B (dBuV)	
	Quasi-peak	Average	Quasi-peak	Average
0.15 - 0.5	79	66	66 - 56	56 - 46
0.50 - 5.0	73	60	56	46
5.0 - 30.0	73	60	60	50

Note: The lower limit shall apply at the transition frequency.

Maximum permissible level of Common Mode Conducted Emission (Telecommunication Ports)

CLASS A

Frequency (MHZ)	Voltage Limit (dBuV)		Current Limit (dBuA)	
	Quasi-peak	Average	Quasi-peak	Average
0.15 - 0.5	97 - 87	84 - 74	53 - 43	40 - 30
0.5 - 30.0	87	74	43	30

Note: The lower limit shall apply at the transition frequency.

CLASS B

Frequency (MHZ)	Voltage Limit (dBuV)		Current Limit (dBuA)	
	Quasi-peak	Average	Quasi-peak	Average
0.15 - 0.5	84 - 74	74 - 64	40 - 30	30 - 20
0.5 - 30.0	74	64	30	20

Note: The lower limit shall apply at the transition frequency.

Maximum permissible level of Radiated Emission measured at 10 meter

Frequency (MHZ)	Class A (dBuV/m)	Class B (dBuV/m)
	Quasi-peak	Quasi-peak
30 - 230	40	30
230 - 1000	47	37

Note: The lower limit shall apply at the transition frequency.



7.2 TEST PROCEDURE OF LINE CONDUCTED EMISSION

Procedure of Preliminary Test

- The EUT was set up as per the test configuration to simulate typical usage per the user's manual. When the EUT is a tabletop system, a wooden table with a height of 0.8 meters is used and is placed on the ground plane as per EN 55022 (see Test Facility for the dimensions of the ground plane used). When the EUT is a floor-standing equipment, it is placed on the ground plane which has a 3-12 mm non-conductive covering to insulate the EUT from the ground plane.
- Support equipment, if needed, was placed as per EN 55022.
- All I/O cables were positioned to simulate typical actual usage as per EN 55022.
- The test equipment EUT installed received AC power, 230VAC/50Hz, through a Line Impedance Stabilization Network (LISN), which supplied power source and was grounded to the ground plane.
- All support equipment received power from a second LISN.
- The EUT test program was started. Emissions were measured on each current carrying line of the EUT using an EMI Test Receiver connected to the LISN powering the EUT.
- The Receiver scanned from 150kHz to 30MHz for emissions in each of the test modes.
- During the above scans, the emissions were maximized by cable manipulation.
- The test mode(s) described in Item 3.2 were scanned during the preliminary test.
- After the preliminary scan, we found the test mode described in Item 3.2 producing the highest emission level.
- The EUT configuration and cable configuration of the above highest emission level were recorded for reference of the final test.

Procedure of Final Test

- EUT and support equipment were set up on the test bench as per the configuration with highest emission level in the preliminary test.
- A scan was taken on both power lines, Line 1 and Line 2, recording at least the six highest emissions. Emission frequency and amplitude were recorded into a computer in which correction factors were used to calculate the emission level and compare reading to the applicable limit. If EUT emission level was less -2dB to the Average limit in Q.P. mode, then the emission signal was re-checked using an Average detector.
- The test data of the worst-case condition(s) was recorded.



Data Sample:

Freq. (MHz)	Q.P. Raw (dBuV)	Average Raw (dBuV)	Q.P. Limit (dBuV)	Average Limit (dBuV)	Q.P. Margin (dB)	Average Margin (dB)	Note
x.xx	43.95	---	73.00	60.00	-29.05	---	L1

- Freq. = Emission frequency in MHz
- Raw dBuV = Uncorrected Analyzer/Receiver reading + Insertion loss of LISN, if it > 0.5 dB
- Limit dBuV = Limit stated in standard
- Margin dB = Reading in reference to limit
- Note = Current carrying line of reading
- “---“ = The emission level complied with the Average limits, with at least 2dB margin limits, so no further recheck.

Calculation Formula

Margin (dB) = RAW (dBuV) – Limit (dBuV)

7.3 TEST PROCEDURE OF COMMON MODE CONDUCTED EMISSION FOR TELECOMMUNICATION PORT

- Selecting ISN for unscreened cable or a current probe for screened cable to take measurement.
- The port of the EUT was connected to the remote side support equipment through the ISN/Current Probe and communication in normal condition.
- Making a overall range scan by using the test receiver controlled by controller and record at least six highest emissions for showing in the test report.
- Emission frequency and amplitude were recorded into a computer in which correction factors were used to calculate the emission level and compare reading to the applicable limit.
- In case of measuring on the screened cable, the current limit shall be applied, otherwise the voltage limit should be applied.
- The following test mode(s) were scanned during the preliminary test:

No applicable, because EUT hasn't LAN Port or Modem Port.



Data Sample:

Freq. (MHz)	Q.P. Raw (dBuV)	AV. Raw (dBuV)	Q.P. Limit (dBuV)	AV. Limit (dBuV)	Q.P. Margin (dB)	AV. Margin (dB)	Note
x.xx	43.95	---	87.00	74.00	-43.05	---	---

- Freq.: Emission frequency
- Raw: Uncorrected Analyzer / Receiver reading
- Limit: Limit stated in standard
- Margin: Reading in reference to limit
- Note: Current carrying line of reading
- “-“: The emission level complied with the Average limits, with at least 2 dB margin, so no further recheck.

7.4 TEST PROCEDURE OF RADIATED EMISSION

Procedure of Preliminary Test

- The equipment was set up as per the test configuration to simulate typical usage per the user’s manual. When the EUT is a tabletop system, a wooden turntable with a height of 0.8 meters is used which is placed on the ground plane. When the EUT is a floor-standing equipment, it is placed on the ground plane which has a 3-12 mm non-conductive covering to insulate the EUT from the ground plane.
- Support equipment, if needed, was placed as per EN 55022.
- All I/O cables were positioned to simulate typical usage as per EN 55022.
- The EUT received AC power source, 230VAC/50Hz, from the outlet socket under the turntable. All support equipment received power from another socket under the turntable.
- The antenna was placed at 10 meter away from the EUT as stated in EN 55022. The antenna connected to the Spectrum Analyzer via a cable and at times a pre-amplifier would be used.
- The Analyzer / Receiver quickly scanned from 30MHz to 1000MHz. The EUT test program was started. Emissions were scanned and measured rotating the EUT to 360 degrees and positioning the antenna 1 to 4 meters above the ground plane, in both the vertical and the horizontal polarization, to maximize the emission reading level.
- The test mode(s) described in Item 3.2 were scanned during the preliminary test:
- After the preliminary scan, we found the test mode described in Item 3.2 producing the highest emission level.
- The EUT and cable configuration, antenna position, polarization and turntable position of the above highest emission level were recorded for the final test.



Procedure of Final Test

- EUT and support equipment were set up on the turntable as per the configuration with highest emission level in the preliminary test.
- The Analyzer / Receiver scanned from 30MHz to 1000MHz. Emissions were scanned and measured rotating the EUT to 360 degrees, varying cable placement and positioning the antenna 1 to 4 meters above the ground plane, in both the vertical and the horizontal polarization, to maximize the emission reading level.
- Recorded at least the six highest emissions. Emission frequency, amplitude, antenna position, polarization and turntable position were recorded into a computer in which correction factors were used to calculate the emission level and compare reading to the applicable limit and only Q.P. reading is presented.
- The test data of the worst-case condition(s) was recorded.

Data Sample:

Freq. (MHz)	Raw Data (dBuV)	Corr. Factor (dB/m)	Emiss. Level (dBuV/m)	Limits (dBuV/m)	Margin (dB)
xx.xx	14.00	12.20	26.20	40.00	-13.80

- Freq. = Emission frequency in MHz
- Raw Data (dBuV) = Uncorrected Analyzer / Receiver reading
- Corr. Factor (dB/m) = Antenna factor + Cable loss – Amplifier gain
- Emiss. Level (dBuV/m) = Raw reading converted to dBuV/m and CF added
- Limit (dBuV/m) = Limit stated in standard
- Margin (dB) = Reading in reference to limit
- P = Peak Reading
- Q = Quasi-peak Reading
- A = Average Reading

Calculation Formula

Margin (dB) = Emiss. Level (dBuV/m) – Limits (dBuV/m)
 Emission Level (dBuV/m) = Raw Data (dBuV) + Corr. Factor (dB/m)



7.5 TEST RESULTS

Line Conducted Emission

Model: N/A

Test Mode: N/A

Temperature: N/A

Humidity: N/A

Tested by: N/A

Test Results: N/A

****Note: This EUT has not connection to AC Source direct. No applicable for this test.**



Radiated Emission (A)

Model: BAS-2520

Test Mode: Mode 1

Temperature: 30°C

Humidity: 64% RH

Detector Function: Quasi-peak.

Antenna: Vertical at 10m

Tested by: Ethan Huang

Test Results: Pass

(The chart below shows the highest readings taken from the final data)

Freq. (MHz)	Raw Data (dBuV)	Corr. Factor (dB/m)	Emiss. Level (dBuV/m)	Limits (dBuV/m)	Margin (dB)
110.51	22.0	11.6	33.6	40.0	-6.4
129.83	22.4	12.0	34.4	40.0	-5.6
150.31	16.2	11.0	27.2	40.0	-12.8
190.30	15.8	11.2	27.0	40.0	-13.0
200.07	14.9	10.8	25.7	40.0	-14.3
209.82	14.2	10.6	24.8	40.0	-15.2
229.35	10.9	10.9	21.8	40.0	-18.2



Radiated Emission (B)

Model: BAS-2520

Test Mode: Mode 1

Temperature: 30°C

Humidity: 64% RH

Detector Function: Quasi-peak.

Antenna: Horizontal at 10m

Tested by: Ethan Huang

Test Results: Pass

(The chart below shows the highest readings taken from the final data)

Freq. (MHz)	Raw Data (dBuV)	Corr. Factor (dB/m)	Emiss. Level (dBuV/m)	Limits (dBuV/m)	Margin (dB)
110.54	22.8	11.6	34.4	40.0	-5.6
129.83	25.9	12.0	37.9	40.0	-2.1
150.30	22.6	11.0	33.6	40.0	-6.4
200.09	13.6	10.8	24.4	40.0	-15.6
209.83	15.0	10.6	25.6	40.0	-14.4
230.24	15.4	11.0	26.4	47.0	-20.6
449.61	8.1	19.0	27.1	47.0	-19.9
480.09	6.3	20.3	26.6	47.0	-20.4



8 POWER HARMONICS TEST

Port : AC mains
Basic Standard : EN 61000-3-2 (2000)
Limits : CLASS A ; CLASS B ; CLASS C ; CLASS D
Tested by : N/A
Temperature : N/A
Humidity : N/A

Limit:

Limits for Class A equipment	
Harmonics Order n	Max. permissible harmonics current A
Odd harmonics	
3	2.30
5	1.14
7	0.77
9	0.40
11	0.33
13	0.21
15<=n<=39	0.15x15/n
Even harmonics	
2	1.08
4	0.43
6	0.30
8<=n<=40	0.23x8/n

Limits for Class D equipment		
Harmonics Order n	Max. permissible harmonics current per watt mA/W	Max. permissible harmonics current A
Odd Harmonics only		
3	3.4	2.30
5	1.9	1.14
7	1.0	0.77
9	0.5	0.40
11	0.35	0.33
13	0.30	0.21
15<=n<=39	3.85/n	0.15x15/n

Block Diagram of Test Setup:

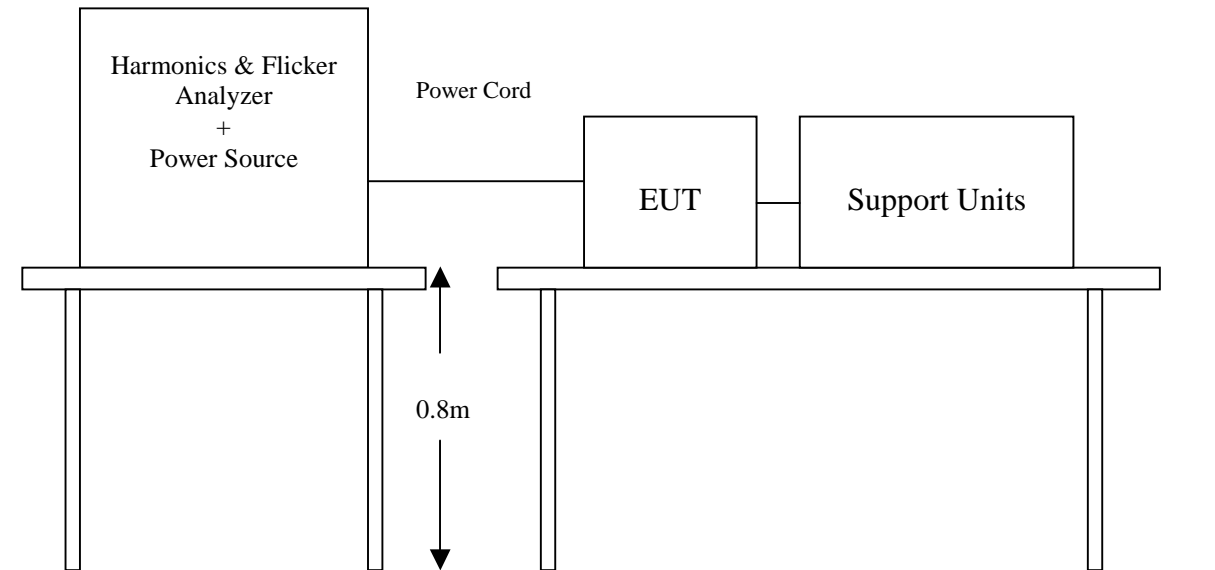

Test Procedure:

- a. The EUT was placed on the top of a wooden table 0.8 meters above the ground and operated to produce the maximum harmonic components under normal operating conditions for each successive harmonic component in turn.
- b. The correspondent test program of test instrument to measure the current harmonics emanated from EUT is chosen. The measure time shall be not less than the time necessary for the EUT to be exercised.

Test Result:

Not applicable, because EUT not connect to AC Main Source direct.

9 POWER VOLTAGE FLUCTUATION / FLICKER TEST

Port : AC mains
Basic Standard : EN 61000-3-3 (1995 + A1: 2001)
Limits : §5 of EN 61000-3-3
Tested by : N/A
Temperature : N/A
Humidity : N/A

Limit:

TEST ITEM	LIMIT	REMARK
P_{st}	1.0	P_{st} means short-term flicker indicator.
P_{lt}	0.65	P_{lt} means long-term flicker indicator.
T_{dt} (ms)	500	T_{dt} means maximum time that dt exceeds 3 %.
d_{max} (%)	4%	d_{max} means maximum relative voltage change.
dc (%)	3.3%	dc means relative steady-state voltage change

Block Diagram of Test Setup:

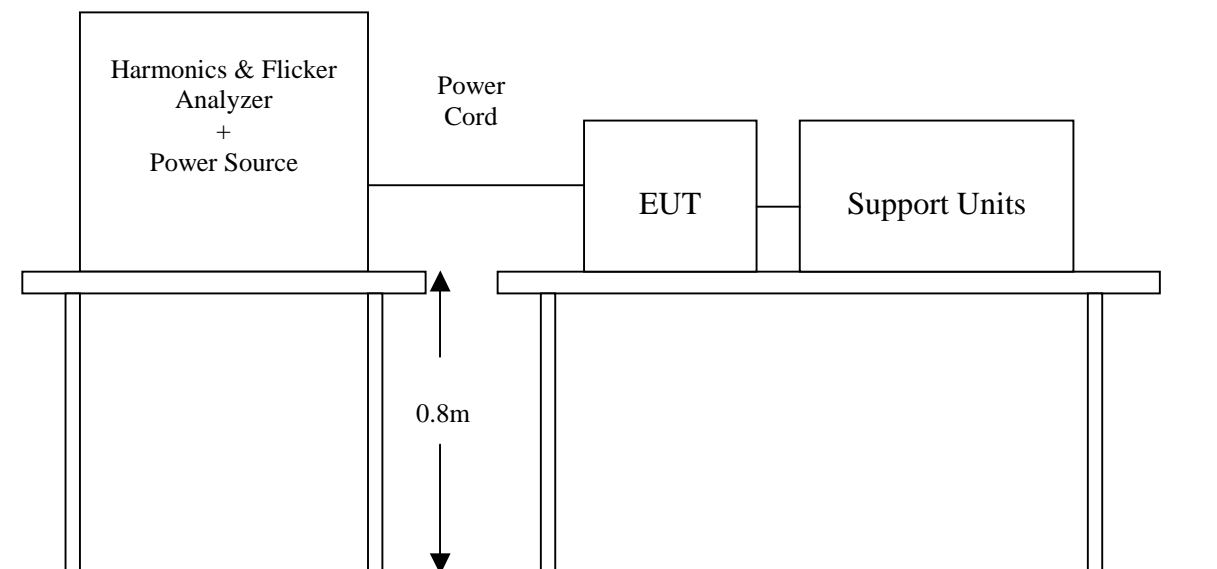



Test Procedure:

- a. The EUT was placed on the top of a wooden table 0.8 meters above the ground and operated to produce the most unfavorable sequence of voltage changes under normal operating conditions.
- b. During the flick measurement, the measure time shall include that part of whole operation cycle in which the EUT produce the most unfavorable sequence of voltage changes. The observation period for short-term flicker indicator is 10 minutes and the observation period for long-term flicker indicator is 2 hours.

Test Result:

Not applicable, because EUT not connect to AC Main Source direct.

10 ELECTROSTATIC DISCHARGE (ESD) IMMUNITY TEST

Port	: Enclosure
Basic Standard	: IEC/EN 61000-4-2
Test Level	: ± 8 kV (Air Discharge) ± 4 kV (Contact Discharge) ± 4 kV (Indirect Discharge)
Performance Criterion	: B (Standard Required)
Tested by	: Bill Cheng
Temperature	: 26°C
Humidity	: 54% RH
Pressure	: 1019mbar

Block Diagram of Test Setup:

(The 470 k ohm resistors are installed per standard requirement.)

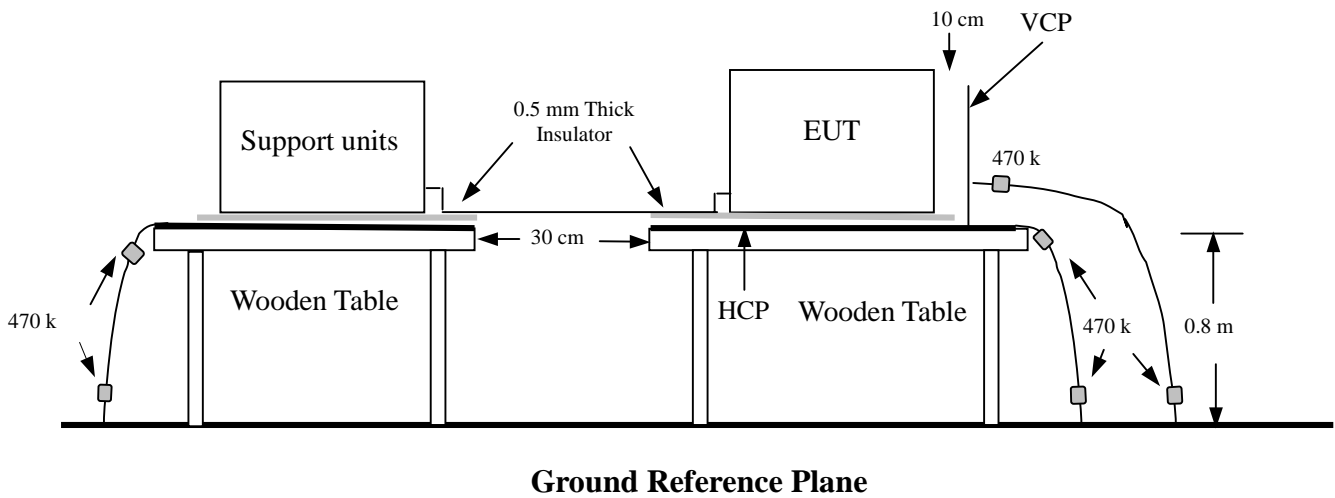

**Test Procedure:**

1. The EUT was located 0.1 m minimum from all side of the HCP.
2. The indirect support units were located 1 m minimum away from the EUT, but direct support unit was/were located at same location as EUT on the HCP and keep at a distance of 10 cm with EUT.
3. As per the requirement of EN 55024; applying direct contact discharge at the sides other than front of EUT at minimum 50 discharges (25 positive and 25 negative) if applicable, can't be applied direct contact discharge side of EUT then the indirect discharge shall be applied. One of the test points shall be subjected to at least 50 indirect discharge (contact) to the front edge of horizontal coupling plane.
4. Other parts of EUT where it is not possible to perform contact discharge then selecting appropriate points of EUT for air discharge, a minimum of 10 single air discharges shall be applied.
5. The application of ESD to the contact of open connectors is not required.
6. The EUT direct connection units also need to be applied ESD at the port of EUT cable connected.
7. Putting a mark on EUT to show tested points. The following test condition was followed during the tests.

Note: As per IEC/EN 61000-4-2, two 470k bleed resistors cable is connected between the EUT and HCP during the test applicable for power ungrounded or battery operating unit only.

The electrostatic discharges were applied as follows:

Amount of discharge	Voltage	Coupling	Result (Pass/Fail)
Mini 10 /Point	± 8 kV	Air Discharge	Pass
Mini 10 /Point	± 4 kV	Contact Discharge	Pass
Mini 25 /Point	± 4 kV	Indirect Discharge HCP	Pass
Mini 25 /Point	± 4 kV	Indirect Discharge VCP (Right)	Pass
Mini 25 /Point	± 4 kV	Indirect Discharge VCP (Left)	Pass
Mini 25 /Point	± 4 kV	Indirect Discharge VCP (Back)	Pass

For the tested points to EUT, please refer to attached page.

(Blue arrow mark for Contact Discharge and red arrow mark for Air Discharge)



Performance & Result:

- Criteria A:** The apparatus continues to operate as intended. No degradation of performance or loss of function is allowed below a performance level specified by the manufacturer, when the apparatus is used as intended. In some cases the performance level may be replaced by a permissible loss of performance.
- Criteria B:** The apparatus continues to operate as intended after the test. No degradation of performance or loss of function is allowed below a performance level specified by the manufacturer, when the apparatus is used as intended. In some cases the performance level may be replaced by a permissible loss of performance. During the test, degradation of performance is however allowed.
- Criteria C:** Temporary loss of function is allowed, provided the functions self recoverable or can be restored by the operation of controls.

<input checked="" type="checkbox"/> PASS <input type="checkbox"/> FAIL
Observation: No function degraded during the tests.

The Tested Points of EUT



11 RADIATED ELECTROMAGNETIC FIELD IMMUNITY TEST

Port	: Enclosure
Basic Standard	: IEC/EN 61000-4-3
Requirements	: 10 V/m / with 80% AM. 1kHz Modulation. (Customer Required)
Performance Criterion	: A (Standard Required)
Tested by	: Bill Cheng
Temperature	: 24°C
Humidity	: 56% RH
Pressure	: 1017mbar

Block Diagram of Test Setup:

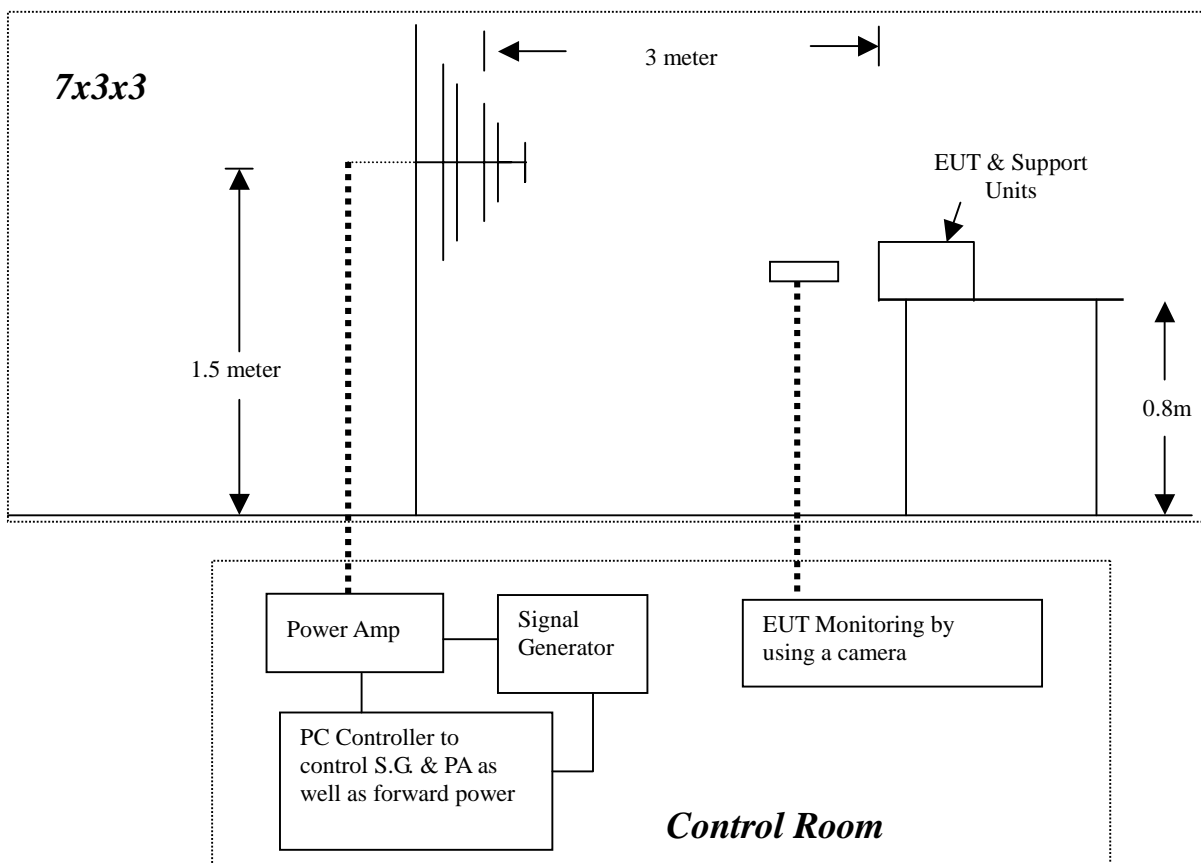



Test Procedure:

1. The EUT was located at the edge of supporting table keep 3 meter away from transmitting antenna, it just the calibrated square area of field uniformity. The support units were located outside of the uniformity area, but the cable(s) connected with EUT were exposed to the calibrated field as per IEC/EN 61000-4-3.
2. Setting the testing parameters of RS test software per IEC/EN 61000-4-3.
3. Performing the pre-test at each side of with double specified level (10V/m) at 4% steps.
4. From the result of pre-test in step 3, choice the worst side of EUT for final test from 80 MHz to 1000 MHz at 1% steps.
5. Recording the test result in following table.
6. It is not necessary to perform test as per annex A of EN 55024 if the EUT doesn't belong to ITE product.

Final test conditions:

Test level : 10V/m
Steps : 1 % of fundamental
Dwell Time : 3 sec

Range (MHz)	Field	Modulation	Polarity	Position	Result (Pass/Fail)
80-1000	10V/m	Yes	H	Right	Pass
80-1000	10V/m	Yes	V	Right	Pass



Performance & Result:

- Criteria A:** The apparatus continues to operate as intended. No degradation of performance or loss of function is allowed below a performance level specified by the manufacturer, when the apparatus is used as intended. In some cases the performance level may be replaced by a permissible loss of performance.
- Criteria B:** The apparatus continues to operate as intended after the test. No degradation of performance or loss of function is allowed below a performance level specified by the manufacturer, when the apparatus is used as intended. In some cases the performance level may be replaced by a permissible loss of performance. During the test, degradation of performance is however allowed.
- Criteria C:** Temporary loss of function is allowed, provided the functions self recoverable or can be restored by the operation of controls.

PASS **FAIL**

Observation: No function degraded during the tests.

12 FAST TRANSIENTS/BURST IMMUNITY TEST

Port	: On Power Supply Line
Basic Standard	: IEC/EN 61000-4-4
Requirements	: ± 2 kV for Power Supply Line (Customer Required)
Performance Criteria	: B (Standard Required)
Tested by	: Bill Cheng
Temperature	: 26°C
Humidity	: 54% RH
Pressure	: 1019mbar

Block Diagram of Test Setup:

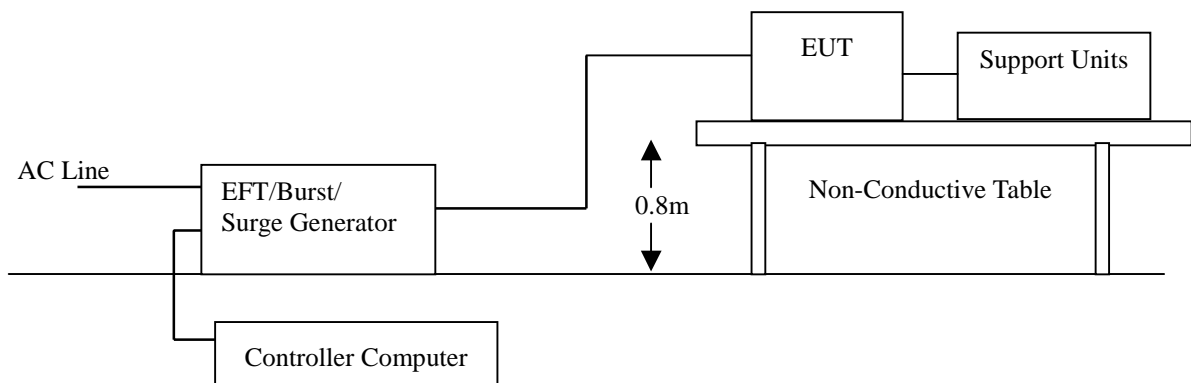

Test Procedure:

1. The EUT and support units were located on a wooden table 0.8 m away from ground reference plane.
2. A 1.0 meter long power cord was attached to EUT during the test.
3. The length of communication cable between communication port and clamp was keeping within 1 meter.
4. Injected test voltage to the EUT ports from minimum to standard request or client request.
5. Recording the test result as shown in following table.



Test conditions:

Impulse Frequency : 5kHz
Tr/Th : 5/50ns
Burst Duration : 15ms
Burst Period : 3Hz

Inject Line	Voltage kV	Inject Method	Result (Pass/Fail)
L	± 2	Direct	Pass
N	± 2	Direct	Pass
L + N	± 2	Direct	Pass

Performance & Result:

- Criteria A:** The apparatus continues to operate as intended. No degradation of performance or loss of function is allowed below a performance level specified by the manufacturer, when the apparatus is used as intended. In some cases the performance level may be replaced by a permissible loss of performance.
- Criteria B:** The apparatus continues to operate as intended after the test. No degradation of performance or loss of function is allowed below a performance level specified by the manufacturer, when the apparatus is used as intended. In some cases the performance level may be replaced by a permissible loss of performance. During the test, degradation of performance is however allowed.
- Criteria C:** Temporary loss of function is allowed, provided the functions self recoverable or can be restored by the operation of controls.

<input checked="" type="checkbox"/> PASS <input type="checkbox"/> FAIL
Observation: No function degraded during the tests.

13 SURGE IMMUNITY TEST

Port : Power Cord
Basic Standard : IEC/EN 61000-4-5
Requirements : ± 1 kV (Line to Line)
Performance Criteria : B (Standard Required)
Tested by : Bill Cheng
Temperature : 26°C
Humidity : 54% RH
Pressure : 1019mbar

Block Diagram of Test Setup:

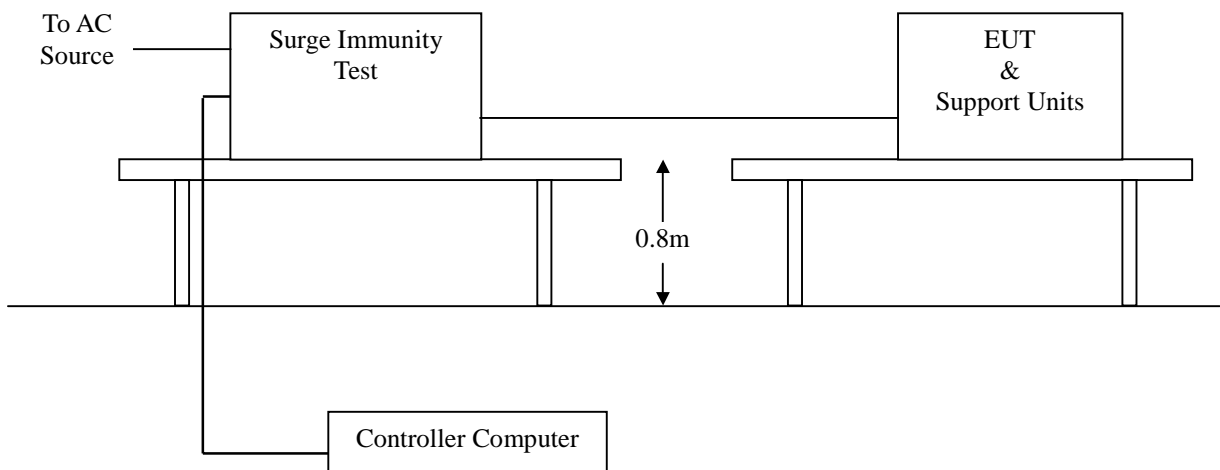

Test Procedure:

1. The EUT and support units were located on a wooden table 0.8 m away from ground floor.
2. Injected test voltage to the EUT ports from minimum to standard request or client request.
3. Recording the test result as shown in following table.



Test conditions:

Voltage Waveform : 1.2/50 us
 Current Waveform : 8/20 us
 Polarity : Positive/Negative
 Phase angle : 0°, 90°, 270°
 Number of Test : 5

Coupling Line	Voltage (kV)	Polarity	Coupling Method	Result (Pass/Fail)
L1-L2	1	Positive	Capacitive	Pass
L1-L2	1	Negative	Capacitive	Pass

Performance & Result:

- Criteria A:** The apparatus continues to operate as intended. No degradation of performance or loss of function is allowed below a performance level specified by the manufacturer, when the apparatus is used as intended. In some cases the performance level may be replaced by a permissible loss of performance.
- Criteria B:** The apparatus continues to operate as intended after the test. No degradation of performance or loss of function is allowed below a performance level specified by the manufacturer, when the apparatus is used as intended. In some cases the performance level may be replaced by a permissible loss of performance. During the test, degradation of performance is however allowed.
- Criteria C:** Temporary loss of function is allowed, provided the functions self recoverable or can be restored by the operation of controls.

<input checked="" type="checkbox"/> PASS <input type="checkbox"/> FAIL
Observation: No function degraded during the tests.

14 CONDUCTED DISTURBANCE/INDUCED RADIO-FREQUENCY FIELD IMMUNITY TEST

Port	: AC Port
Basic Standard	: IEC/EN 61000-4-6
Requirements	: 10 V with 80% AM. 1kHz Modulation. (Customer Required)
Injection Method	: CDN-M2 for Power Cord
Performance Criterion	: A (Standard Required)
Tested by	: Bill Cheng
Temperature	: 24°C
Humidity	: 56% RH
Pressure	: 1017mbar

Block Diagram of Test Setup:

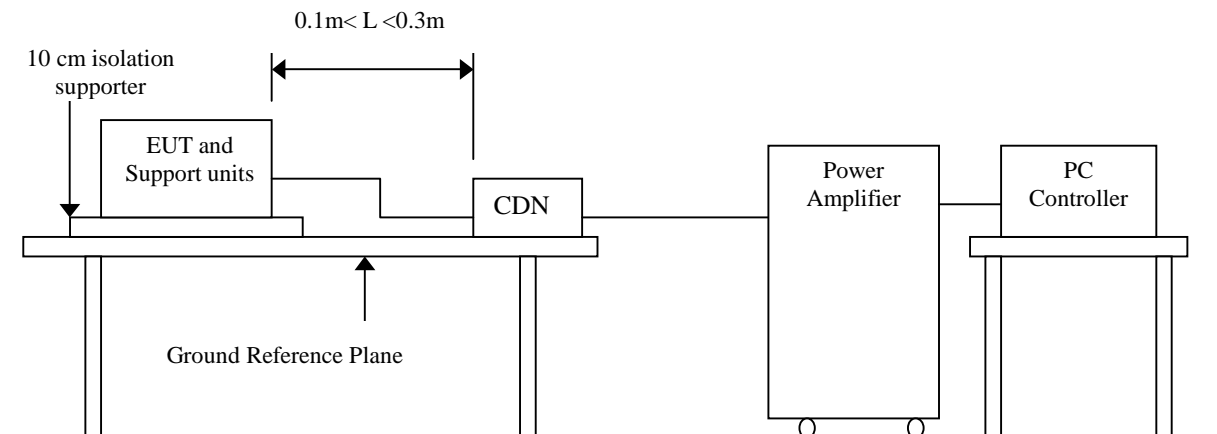

Test Procedure:

1. The EUT and support units were located at a ground reference plane with the interposition of a 0.1 m thickness insulating support and the CDN was located on GRP directly.
2. Setting the testing parameters of CS test software as per IEC/EN 61000-4-6.
3. Recording the test result in following table.



Test conditions:

Frequency Range : 0.15MHz-80MHz

Frequency Step : 1% of fundamental

Dwell Time : 3 sec

Range (MHz)	Field	Modulation	Result (Pass/Fail)
0.15-80	10V	Yes	Pass

Performance & Result:

- Criteria A:** The apparatus continues to operate as intended. No degradation of performance or loss of function is allowed below a performance level specified by the manufacturer, when the apparatus is used as intended. In some cases the performance level may be replaced by a permissible loss of performance.
- Criteria B:** The apparatus continues to operate as intended after the test. No degradation of performance or loss of function is allowed below a performance level specified by the manufacturer, when the apparatus is used as intended. In some cases the performance level may be replaced by a permissible loss of performance. During the test, degradation of performance is however allowed.
- Criteria C:** Temporary loss of function is allowed, provided the functions self recoverable or can be restored by the operation of controls.

<input checked="" type="checkbox"/> PASS <input type="checkbox"/> FAIL
--

<p>Observation: No function degraded during the tests.</p>

15 POWER FREQUENCY MAGNETIC FIELD IMMUNITY TEST

Port	: Enclosure
Basic Standard	: IEC/EN 61000-4-8
Requirements	: 30 A/m (Customer Required)
Performance Criterion	: A (Standard Required)
Tested by	: Bill Cheng
Temperature	: 26°C
Humidity	: 54% RH
Pressure	: 1019mbar

Block Diagram of Test Setup:

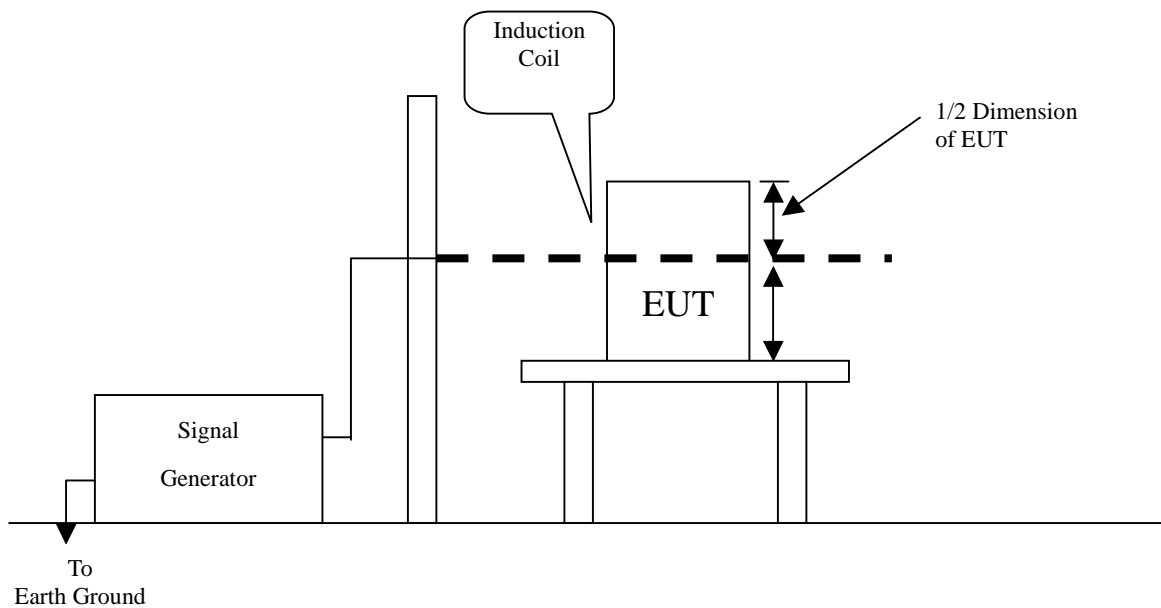

Test Procedure:

1. The EUT and support units were located on Ground Reference Plane with the interposition of a 0.1 m thickness insulation support.
2. Putting the induction coil on horizontal direction. (X direction)
3. Rotating the induction coil by 90° (Y direction)
4. Rotating the induction coil by 90° again (Z direction)
5. Recording the test result as shown in following table.



Test conditions:

Field Strength: 30A/m
Power Freq.: 50Hz
Orientation: X, Y, Z

Orientation	Field	Result (Pass/Fail)	Remark
X	30A/m	Pass	
Y	30A/m	Pass	
Z	30A/m	Pass	

Performance & Result:

- Criteria A:** The apparatus continues to operate as intended. No degradation of performance or loss of function is allowed below a performance level specified by the manufacturer, when the apparatus is used as intended. In some cases the performance level may be replaced by a permissible loss of performance.
- Criteria B:** The apparatus continues to operate as intended after the test. No degradation of performance or loss of function is allowed below a performance level specified by the manufacturer, when the apparatus is used as intended. In some cases the performance level may be replaced by a permissible loss of performance. During the test, degradation of performance is however allowed.
- Criteria C:** Temporary loss of function is allowed, provided the functions self recoverable or can be restored by the operation of controls.

<input checked="" type="checkbox"/> PASS <input type="checkbox"/> FAIL
Observation: No function degraded during the tests.



16 VOLTAGE DIPS / SHORT INTERRUPTIONS

Port : AC mains

Basic Standard : IEC/EN 61000-4-11

Requirement : PHASE ANGLE 0, 45, 90, 135, 180, 225, 270, 315 degrees

Voltage Dips	Test Level % U_T	Reduction (%)	Duration (periods)	Performance Criteria
	<5	>95	0.5	B
	70	30	25	C

Voltage Interceptions	Test Level % U_T	Reduction (%)	Duration (periods)	Performance Criteria
	<5	>95	250	C

Test Interval : Min. 10 sec.

Tested by : N/A

Temperature : N/A

Humidity : N/A

Pressure : N/A

Performance & Result:

Criteria A: The apparatus continues to operate as intended. No degradation of performance or loss of function is allowed below a performance level specified by the manufacturer, when the apparatus is used as intended. In some cases the performance level may be replaced by a permissible loss of performance.

Criteria B: The apparatus continues to operate as intended after the test. No degradation of performance or loss of function is allowed below a performance level specified by the manufacturer, when the apparatus is used as intended. In some cases the performance level may be replaced by a permissible loss of performance. During the test, degradation of performance is however allowed.

Criteria C: Temporary loss of function is allowed, provided the functions self recoverable or can be restored by the operation of controls.

PASS FAIL

Not applicable, because EUT not connect to AC Main Source direct.

APPENDIX I - PHOTOGRAPHS OF TEST SETUP

RADIATED EMISSION TEST (EN 55022)



ELECTROSTATIC DISCHARGE TEST



RADIATED ELECTROMAGNETIC FIELD TEST



FAST TRANSIENTS/BURST TEST



SURGE IMMUNITY TEST



CONDUCTED DISTURBANCE, INDUCED BY RADIO-FREQUENCY FIELDS TEST

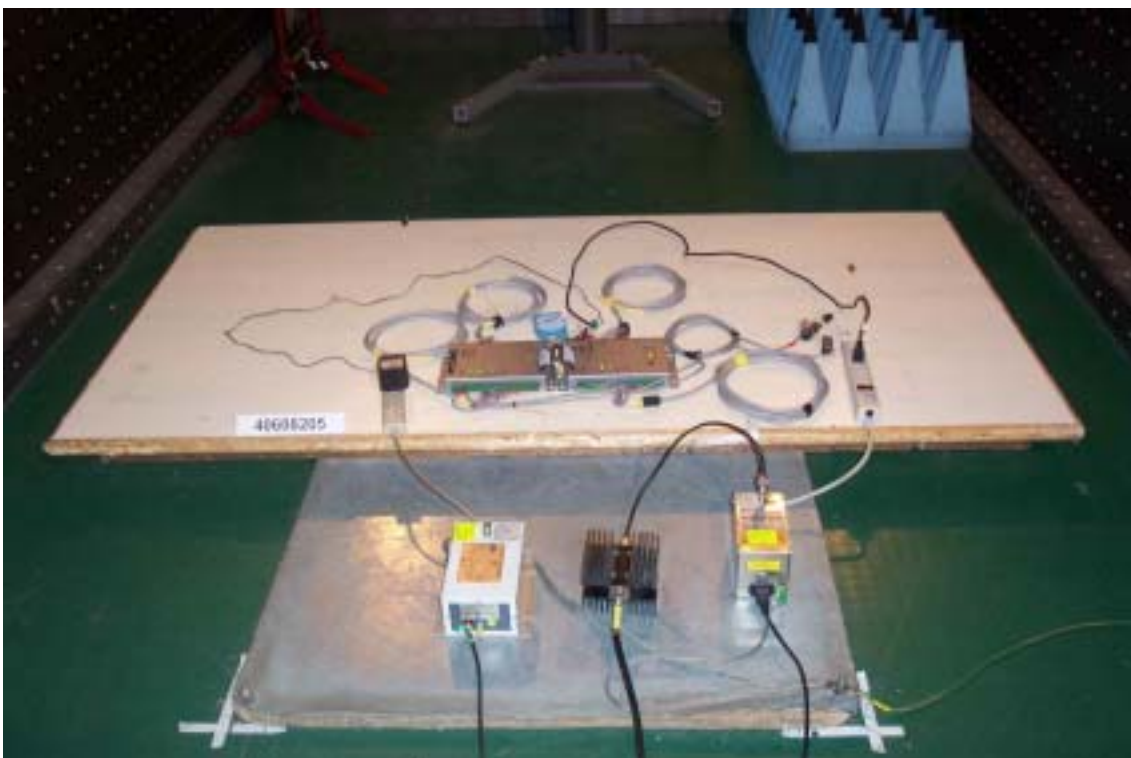

POWER FREQUENCY MAGNETIC FIELD IMMUNITY TEST

