

Introduction

This instruction document is the appendix for heat sink installation for MIC-3377 series. In order to assembly the heat sink well, we create this document for system assemblers or our distributors. This document focuses on installation between flat screws and washers those were out of original description in user's manual.

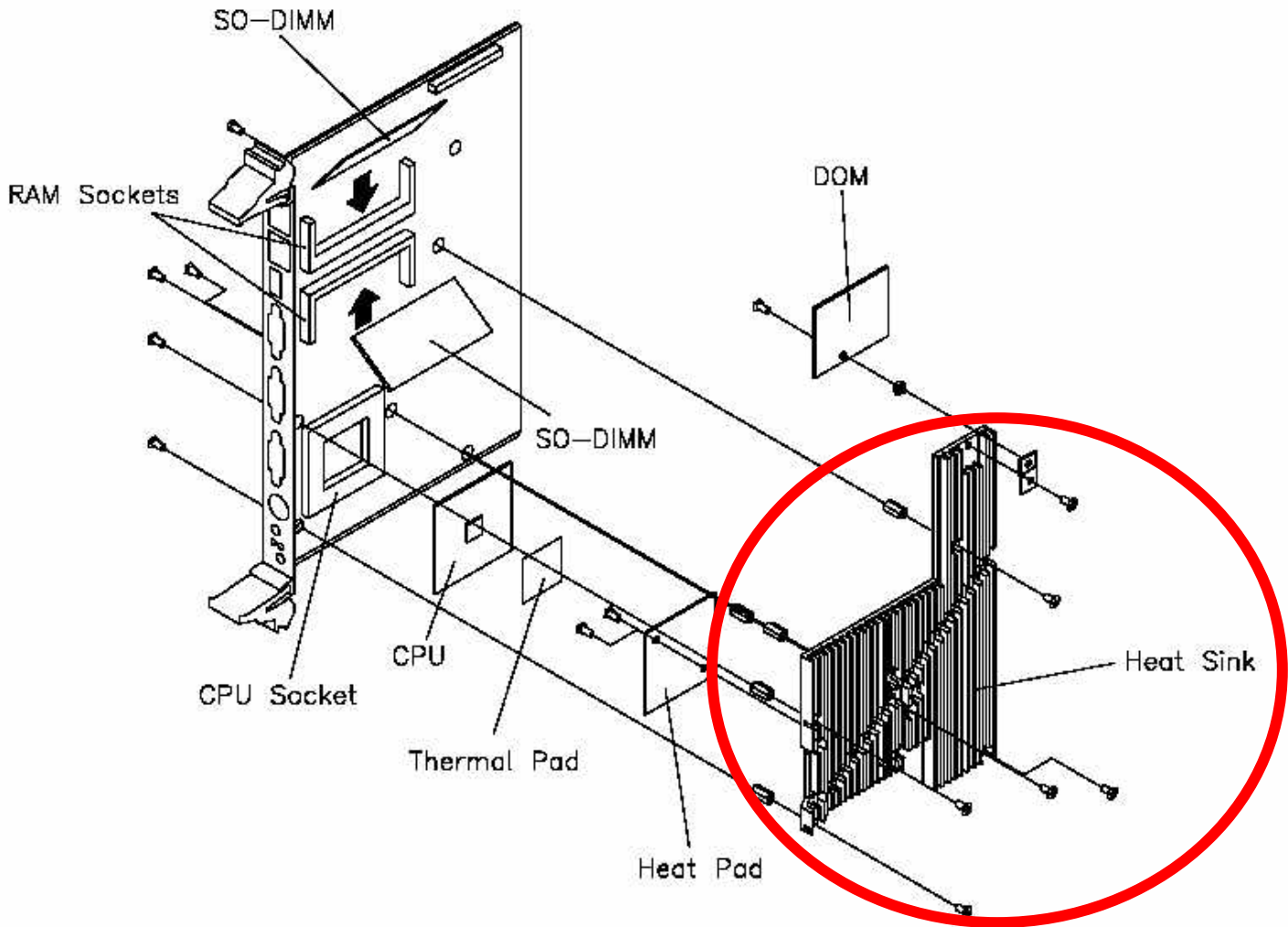

Assembly of components for the heat sink plate

Please refer to the following figures to see all parts in accessory box for the installation.

FLAT M3X8 NI (+)

FLAT WASHER 3.2*8*0.8

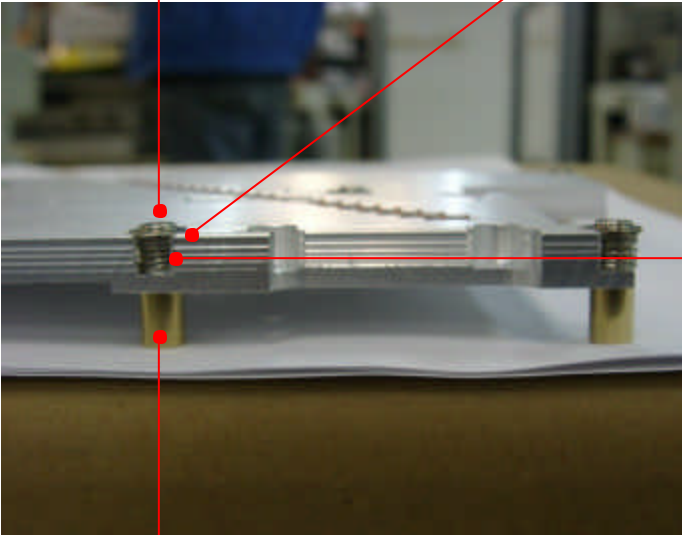

Spring for heat sink

heat sink copper post
for MIC-3377 A1

