



DaqBoard/3000USB™ Series

USB 1-MHz, 16-Bit Data Acquisition Boards

Features

- Designed for OEM and embedded applications
- Custom versions available for OEMs (contact factory)
- 16-bit, 1-MHz A/D converter
- Up to 32 differential or 64 single-ended analog inputs, four of which can accept thermocouples
- Up to four 16-bit, 1-MHz analog outputs
- 24 high-speed digital I/O lines
- Four 32-bit counters with quadrature encoding support
- Low-latency set-point control output mode
- Small, compact design (6" x 5.93")

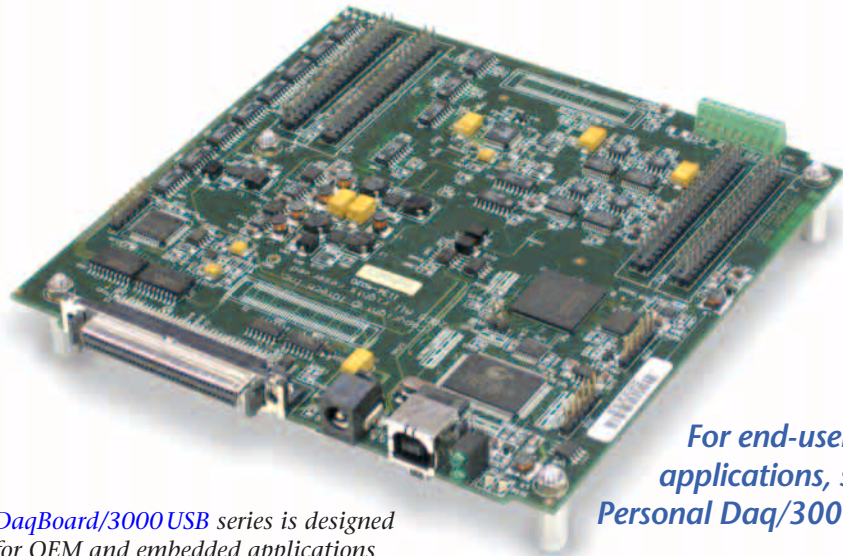

For end-user applications, see **Personal Daq/3000 Series**

DaqBoard/3000USB series is designed for OEM and embedded applications

Software

- **DaqView™ Out-of-the-Box™** software application for effortless data logging and analysis
- Support for Visual Studio® and Visual Studio® .NET, including examples for Visual C++®, Visual C#®, Visual Basic®, and Visual Basic® .NET
- Comprehensive drivers for **DASYLab®**, **LabVIEW®**, and **MATLAB®**
- **DaqCal™** software application for easy user-calibration

The new USB 2.0 **DaqBoard/3000USB** series offers high-speed, multifunction data acquisition in a low-cost, board only design. Each board offers synchronous and concurrent voltage input, temperature input, waveform output, counter input, quadrature encoder input, timer output, and digital I/O. Everything needed to begin acquiring, viewing, and storing data is included with the **DaqBoard/3000USB**, including comprehensive software support.

The **DaqBoard/3000USB** series feature a 16-bit/1-MHz A/D converter, up to 64 analog inputs, up to four 16-bit/1-MHz analog outputs, 24 high-speed digital I/O, 2 timer outputs, and four 32-bit counters. All analog I/O, digital I/O, and counter/timer I/O can operate synchronously and simultaneously, guaranteeing deterministic I/O among all signal types.

Unique to the **DaqBoard/3000USB** series is a low-latency, highly deterministic control output mode that operates independent of the PC. In this mode digital, analog, and timer

Model	Analog Inputs	Analog Outputs	Digital I/O	Counters	Timers
DaqBoard/3005USB	16SE/8DE	0	24	4	2
DaqBoard/3001USB	16SE/8DE	4	24	4	2
DaqBoard/3035USB	64SE/32DE	0	24	4	2
DaqBoard/3031USB	64SE/32DE	4	24	4	2

Note: Up to 4 of the analog inputs can be used to measure thermocouples

DaqBoard/3000USB Physical Dimensions

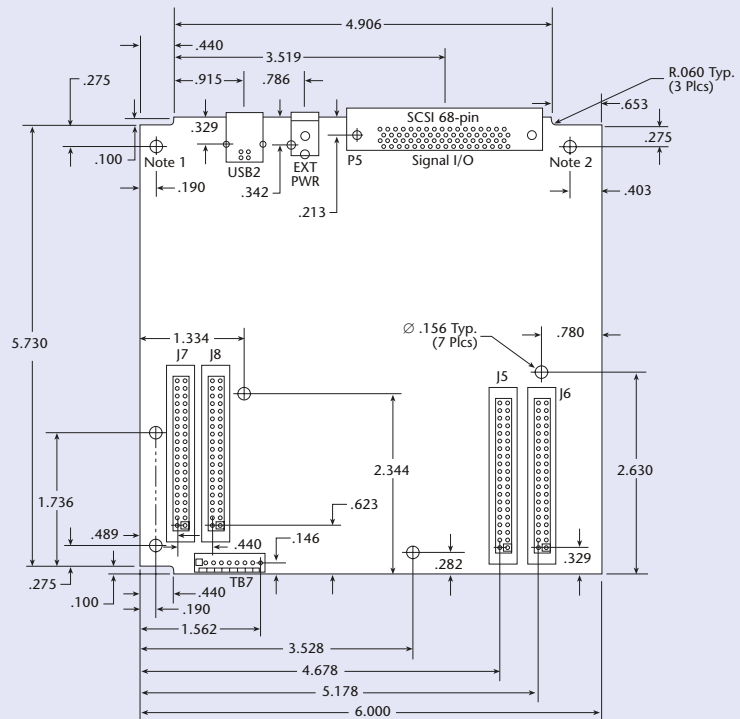

In general, all standoffs should be used to mount the board to a metal frame.
 Note 1: The standoff at this location connects to the USB chassis for shunting electrostatic discharge.
 Note 2: The standoff at this location connects to the DaqBoard/3000USB board's internal chassis plane for shunting electrostatic discharge.



DaqBoard/3000USB™ Series

General Information

outputs can respond to analog, digital and counter inputs as fast as 2 μ s; at least 1,000 times faster than other products that rely on the PC for decision making.

Other Hardware Features Include:

- Encoder measurements up to 20 MHz, including Z-channel zeroing
- Frequency and pulse-width measurements with 20.83 ns resolution
- Timing mode that can measure the time between two counter inputs to 20.83 ns resolution
- Self-calibration

Software

Included with the [DaqBoard/3000USB](#) series is new [DaqView™](#) software, a comprehensive *Out-of-the-Box™* application that enables set-up, data logging, and real-time data viewing without any programming skills. Optional [DaqView/Pro](#) adds features such as direct-to-Excel® enhancements, FFT analysis, statistics, etc., all for a small additional price.

Also included with the [DaqBoard/3000USB](#) series is a complete set of drivers and detailed example programs for the most popular programming languages and software packages. Driver support includes Visual Basic®, C/C++, LabVIEW®, DASyLab®, and MATLAB®. DaqCOM™ provides Windows®-based ActiveX/COM-based programming tools for Microsoft® Visual Studio® and Visual Studio® .NET.

Technical Support

IOtech offers unlimited free technical support for DaqBoard purchasers. Other vendors place a limit on support or require expensive service contracts, while IOtech provides free access to hardware and software engineers to assist you in developing your application and using your IOtech product.

Signal Connections

A 68-pin SCSI connector provides access to 16SE/8DE analog inputs, up to 4 analog outputs, 24 digital I/O, counters and timers. Each board is also equipped with four sets of header connectors that also provide connection to the signals on the 68-pin connector as well as an additional 48SE/24DE analog inputs (on the /3035USB and

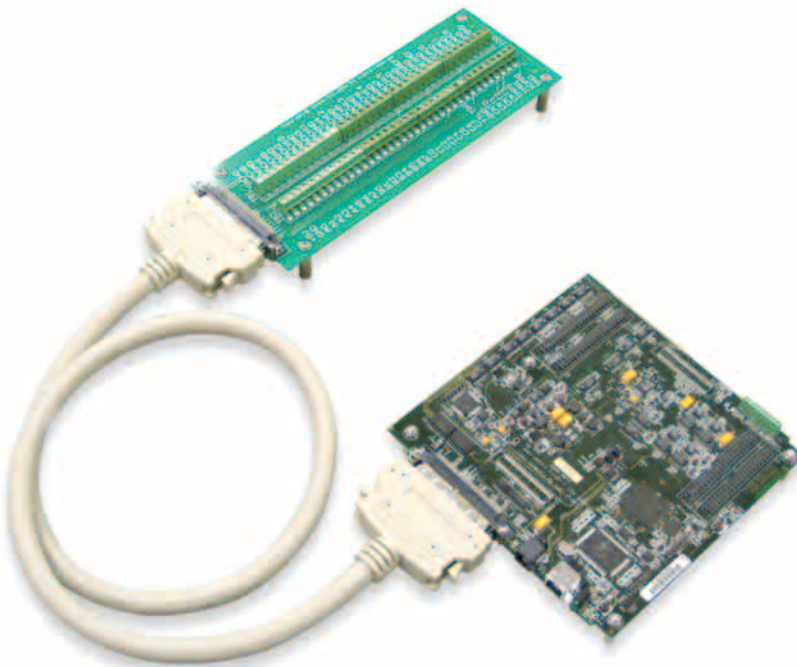

DaqBoard/3001USB attached to a TB-100 screw-terminal board

/3031USB models). These headers can be used to connect to the CA-248 cable or to custom, user provided cables. A four channel screw-terminal connector is provided for using the four thermocouple inputs on the [DaqBoard/3000USB](#) series.

The TB-101 is a screw terminal board that connects directly to the 40-pin headers on the back on each DaqBoard. It is secured to the board with included stand-offs. The TB-101 provides screw terminal access to up to 64SE/32DE analog inputs (when using a 3035 or 3031 model), up to 4 analog outputs, 24 digital I/O and all counters/timers.

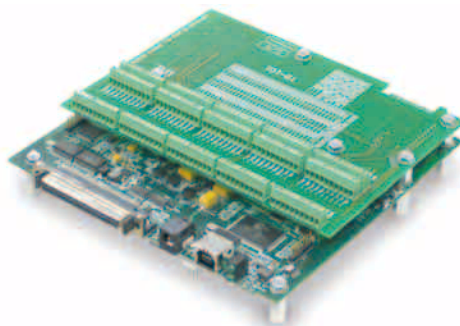

DaqBoard/3001USB with TB-101 screw-terminal board attached

The TB-100 screw terminal board is attached via a CA-G5x-x cable to the 68-pin SCSI connector on a [DaqBoard/3000USB](#) series board. The TB-100 provides screw terminal access to 16SE/8DE analog inputs, up to 4 analog outputs, 24 digital I/O and all counters/timers. When using the TB-100 with the 3035 or 3031 models, the remaining 48SE/24DE analog inputs are accessed through the 40-pin headers.

Analog Input

The [DaqBoard/3000USB](#) series has a 16-bit, 1-MHz A/D coupled with 16 single-ended, 8 differential analog inputs (3005 and 3001 models), 64 single-ended, or 32 differential analog inputs (3035 and 3031 models). Four of the analog inputs can be configured as four differential thermocouple inputs (all models). Seven software programmable ranges provide inputs from ± 10 V to ± 100 mV full scale. Each channel can be software-configured for a different range, as well as for single-ended or differential bipolar input, or thermocouple input.

Four analog inputs on the [DaqBoard/3000USB](#) can accept a thermocouple (TC) input. Built-in cold-junction sensors are provided for each of the screw-terminal connectors, and



DaqBoard/3000USB™ Series

General Information

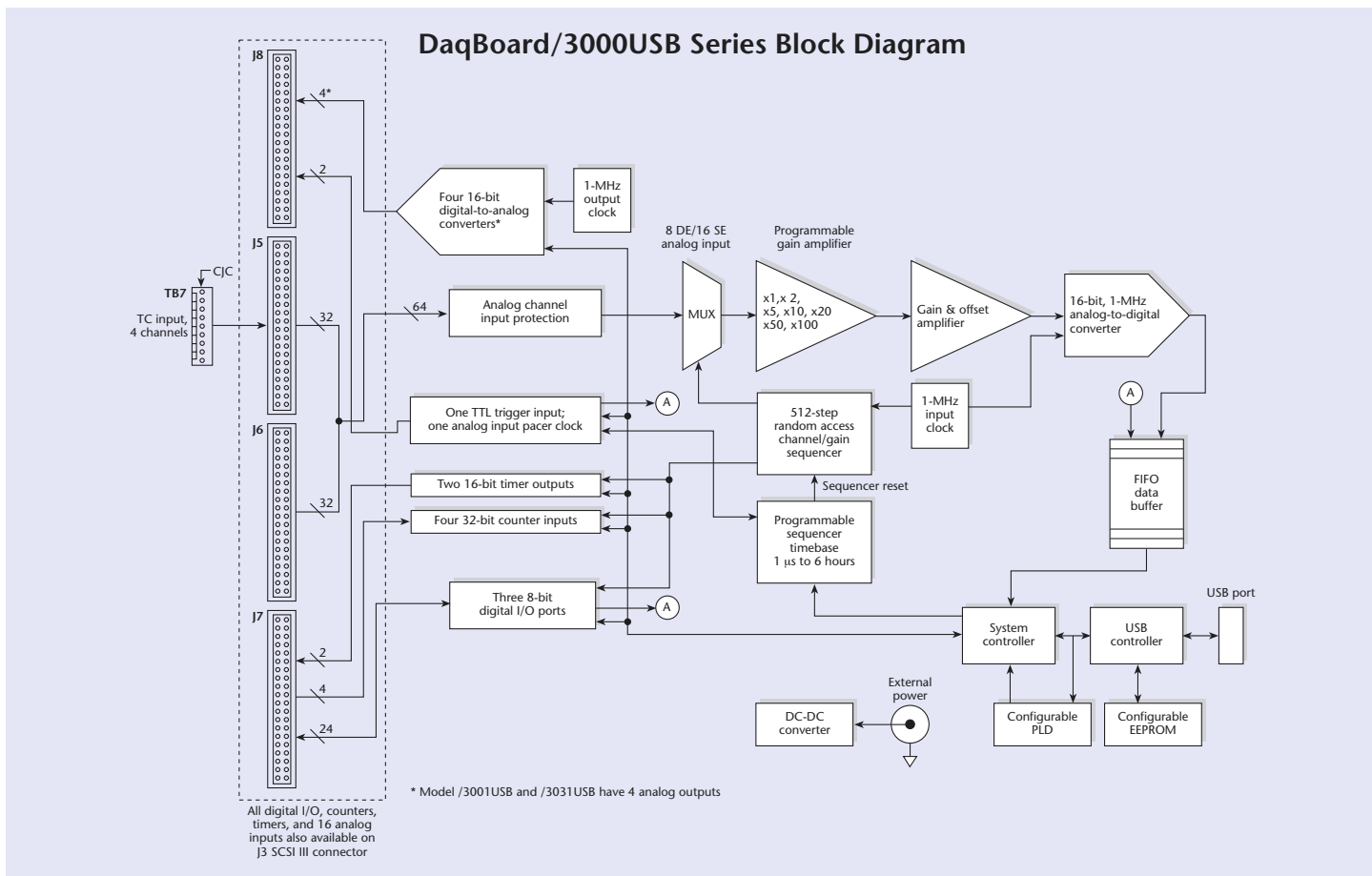

any TC type can be attached to any channel. When measuring TCs the DaqBoard operates in an over-sample mode, where multiple readings are taken on each TC channel, digitally filtered, cold-junction compensated, and converted to temperature. As a result, channels with TC's attached are measured at a rate from 50 Hz to 10 kHz, depending on how much over sampling is selected. In-line cycle rejection mode, over sampling occurs during one cycle of either 50 Hz or 60 Hz, providing a high level of 50 Hz or 60 Hz rejection.

Synchronous I/O

The DaqBoard/3000USB series can make analog measurements and read digital and counter inputs, while synchronously generating up to four analog outputs as well as digital pattern outputs. Digital and counter inputs do not affect the overall A/D rate because they use no time slot in the scanning sequencer. For example,

an analog input channel can be scanned at the full 1-MHz A/D rate along with digital and counter input channels. The 1-MHz A/D rate is unaffected by the additional digital and counter channels. Other data acquisition devices provide no capability to scan digital/counter channels concurrent with analog channels, in which case digital and counter channels must be read asynchronously, which leads to a non-deterministic collection of data.

Input Scanning

The DaqBoard/3000USB has several scanning modes to address a wide variety of applications. A 512 location scan buffer can be loaded by the user with any combination of analog input channels. All analog input channels in the scan buffer are measured sequentially at 1 μ s per channel. The user can also specify that the sequence repeat immediately, or repeat after a programmable delay from 0 to 19 hours, with 20.83 ns resolution.

For example, in the fastest mode, with a 0 delay, a single analog channel can be scanned continuously at 1 Msamples/s; two analog channels can be scanned at 500 Ksamples/s each; 16 analog input channels can be scanned at 62.5 Ksamples/s.

DaqBoard/3000USB digital inputs and counter inputs can be read in several modes. First, via software the digital inputs, or counter inputs can be read asynchronously at anytime before, during, or after an analog input scan sequence. This mode is not deterministic as to exactly when the digital or counter input is read relative to an analog input channel.

In either of the two synchronous modes, the digital inputs and/or counter inputs are read with deterministic time correlation to the analog inputs. In the once-per-scan mode, all of the enabled digital inputs and counter inputs are read during the first analog measurement of an analog input



DaqBoard/3000USB™ Series

General Information

scan sequence. The advantage of this mode as compared to most other devices is the digital and counter inputs do not consume an analog input time slot, and therefore do not reduce the available bandwidth for analog input measurements. For example, presume all 24 bits of digital input are enabled, and all four 32-bit counters are enabled, and eight channels of analog inputs are in the scan sequence at the full 1 μ s/channel rate. At the beginning of each analog input scan sequence, which would be 8 μ s in total duration, all digital inputs and counter inputs will be measured and transferred to the PC during the first μ s of the analog scan sequence.

Another synchronous mode is where digital inputs are scanned every time an analog input channel is scanned. For example, if eight analog inputs are scanned at 1 μ s per channel continuously, and 24 bits of digital inputs are enabled, then the 24 bits of digital inputs will be scanned at 24 bits per 1 μ s. If counters are enabled in this mode, they will be scanned at once per scan, in the same manner as in the prior example.

Output Timing

The digital and analog outputs on the DaqBoard/3000USB can be updated asynchronously or synchronously in several modes. In the asynchronous mode, digital and analog outputs can be updated at anytime before, during, or subsequent to an analog input sequence. The maximum update rate in this mode is non-deterministic and entirely dependent on the PC processor speed, the operating system, and programming environment.

In the synchronous output modes, the outputs can be updated continuously from the PC, or as the direct result of an input from either an analog channel, digital channel, or counter channel. When updated from the PC, the user can specify the rate by which the output is updated in 20.83 ns intervals, and outputs are updated synchronously at a maximum rate of 1 μ s. For example, all four 16-bit analog outputs can be generating different waveforms from PC memory, while up to 16 bits of digital pattern could be generated from PC memory concurrently. The maximum rate of output is dependent on a number of

factors, including the speed of the USB implementation on the PC. Typically, a total output bandwidth of 16-bits/ μ s can easily be achieved.

Low-Latency Setpoint Control Mode

The other synchronous method of output is where either a digital, analog, or timer output is associated with any input – analog, digital, or counter. The state or level of the output is determined by the level or state of an associated input. For example, a digital output can be programmed to be a logic 1 when an analog input exceeds a certain value, or when a frequency input exceeds a certain rate. In addition, hysteresis can be programmed for each limit to insure the output is stable near the transition point. Up to 8 digital outputs, 4 analog outputs, and 2 timer outputs can be programmed to respond to any analog, digital, or counter input. When analog or digital outputs are used in this mode, the user can specify two output values, determined by whether the input is above or below the limit.

The slowest rate by which an output can respond to an input is 2 μ s plus the time period of a scan sequence. For example, if 4 channels of analog input are scanned continuously at 4 μ s per scan, then the maximum latency between an analog input satisfying a limit, and the output responding, is 4 + 2 or 6 μ s max. The worst-case response time can also be improved in several ways. For example, if a digital output is correlated to a digital input, then the worst-case latency can be reduced to 2 μ s total if all digital inputs are scanned at the 1 μ s rate without a delay period at the end of each scan.

In addition, an output status channel can be specified in the input scan sequence buffer so that users can correlate output state changes to their respective input channels within their data buffers and files. Adding the status channel takes no additional scan time and has no effect on the overall acquisition rate. The status channel can also be read asynchronously at any time during an acquisition for monitoring of the control outputs.

The advantage of this mode as compared to other boards is the response time can be in the range of 2 to 20 μ s, vs. 1000 or more microseconds when using other supplier's boards.

Triggering

The DaqBoard/3000USB series supports a full complement of trigger modes to accommodate any measurement application.

Hardware Analog Triggering. The DaqBoard/3000USB series uses true analog triggering, whereby the trigger level programmed by the user sets an analog DAC, which is then compared in hardware to the analog input level on the selected channel. The result is analog trigger latency which is guaranteed to be less than 1.3 μ s, significantly shorter than most data acquisition boards. Any analog channel can be selected as the trigger channel. The user can program both the trigger level, as well as the edge (rising or falling), and hysteresis.

Digital Triggering. A separate digital trigger input line is provided, allowing TTL-level triggering with latencies guaranteed to be less than 1 μ s. Both the logic levels (1 or 0), as well as the edge (rising or falling), can be programmed for the discrete digital trigger input.

Pattern Triggering. The user can specify a 16-bit digital pattern to trigger an acquisition, including the ability to mask or ignore specific bits.

Software-Based Channel Level Triggering. This mode differs from the modes described previously because the readings, analog, digital, or counter, are interrogated by the PC in order to detect the trigger event. Triggering can also be programmed to occur when one of the counters reaches, exceeds, or is within a programmed window. Any of the built-in counter/totalizer channels can be programmed as a trigger source. Triggers can be detected on scanned digital input channel patterns as well.

Normally software-based triggering results in long latencies from the time that a trigger condition is detected, until the actual capturing of data commences. However, the



DaqBoard/3000USB™ Series

General Information

DaqBoard/3000USB series circumvents this undesirable situation by use of pre-trigger data. Specifically, when software-based triggering is employed, and the PC detects that a trigger condition has occurred, (which may be thousands of readings later than the actual occurrence of the signal), the DaqBoard driver automatically looks back to the location in memory where the actual trigger-causing measurement occurred. The acquired data that is presented to the user actually begins at the point where the trigger-causing measurement occurs. The maximum latency in this mode is equal to one scan period.

Multi-Channel Triggering. The **DaqBoard** can also be configured to trigger on any combination of analog, digital, and counter inputs (not on temperature measurements, however). In this mode, the maximum latency is one scan period. Triggering can occur based on a logical “and” or logical “or” of the multiple trigger conditions. For example, a trigger condition can be programmed to occur when several analog input channels reach their respective trigger level, *and* several digital inputs are in the proper logic state, *and* several counters exceed or are below a pre-programmed frequency.

Stop Trigger. Any of the software trigger modes described previously including scan count can also be used to stop an acquisition. Thus an acquisition can be programmed to begin on one event, such as a voltage level, and then can stop on another event, such as a digital pattern.

Pre- and Post-Triggering Modes. Six modes of pre- and post-triggering are supported, providing a wide variety of options to accommodate any measurement requirement. When using pre-trigger, the user must use software-based triggering to initiate an acquisition.

No pre-trigger, post-trigger stop event. This mode acquires data upon receipt of the trigger, and stops acquiring upon receipt of the stop-trigger event.

Fixed pre-trigger with post-trigger stop event. In this mode the user specifies the number of pre-trigger readings to be acquired, after which acquisition continues until a stop-trigger event occurs.

No pre-trigger, infinite post-trigger. No pre-trigger data is acquired in this mode. Instead, data is acquired beginning with the trigger event, and is terminated when the operator issues a command to halt the acquisition.

Fixed pre-trigger with infinite post-trigger. The user specifies the amount of pre-trigger data to acquire, after which the system continues to acquire data until the program issues a command to halt acquisition.

Variable pre-trigger with post-trigger stop event*. Unlike the previous pre-trigger modes, this mode does not have to satisfy the pre-trigger number of readings before recognizing the trigger event. Thus the number of pre-trigger readings acquired is variable and dependent on the time of the trigger event relative to the start. In this mode, data continues to be acquired until the stop-trigger event is detected.

Variable pre-trigger with infinite post-trigger*. This mode is similar to the mode described above, except that the acquisition is terminated upon receipt of a command from the program to halt the acquisition.

Calibration

Every range on the **DaqBoard/3000USB** is calibrated from the factory using a digital NIST traceable calibration method. This method works by storing a correction factor for each range on the unit at the time of calibration. The user can adjust the calibration of the board while in their system, without destroying the factory calibration supplied with the board. This is accomplished by having three distinct calibration tables in the **DaqBoard/3000USB** series on-board EPROM, one which contains the

factory cal, and two which are available for user calibration. The user can select any of the three cal tables provided: factory, user, or self-cal tables by API call, or within software provided by IOtech.

Included with each **DaqBoard** is **DaqCal™** software, an easy-to-operate, user-calibration package, allowing users to calibrate their **DaqBoard**. Two calibration modes are supported in **DaqCal**. Self-cal, a user cal mode for analog inputs, can be performed automatically in minutes with included software and without the use of external hardware or instruments. Self-cal derives its traceability through an on-board reference which has a stability of 0.005% per year. The second mode, user-cal, is for users that require traceability to international standards such as NIST. A 6-1/2 digital multimeter is required and user-calibration software is included with step-by-step instructions for full calibration. This process is automated when using a digital multimeter specified by IOtech**. A 2-year calibration period is recommended for the **DaqBoard/3000USB** series.

Analog Output

(DaqBoard/3001USB and /3031USB Only)
Four 16-bit, 1-MHz analog output channels are built into the **DaqBoard/3000USB** series with an output range from -10V to +10V. The maximum rate at which analog outputs can be updated is dependent on several factors, including the speed of your USB port. Typically, with the A/D operating at full 1 Mreading/s rates, one analog output can be updated continuously from PC memory at 1 MHz, or two analog outputs at 500 kHz, and four analog outputs at 250 kHz†. In addition, a program can asynchronously output a value to any of the D/As for non-waveform applications, presuming that the D/A is not already being used in the waveform output mode. Lastly, each of the analog outputs can be used in a control mode, where their output level is dependent on whether an associated analog, digital, or counter input is above or below a user-specified limit condition.

* Driver support only

** Contact factory for user calibration availability

† If waveform output throughput is critical to your application, contact factory for the most recent update on multi-channel DAC output rates



DaqBoard/3000USB™ Series

General Information

When used to generate waveforms, the D/As can be clocked in several different modes. Each D/A can be separately selected to be clocked from one of the sources described as follows.

Asynchronous Internal Clock. The on-board programmable clock can generate updates ranging from once every 19 hours to 1 MHz, independent of any acquisition rate.

Synchronous Internal Clock. The rate of analog output update can be synchronized to the acquisition rate derived from 1 MHz to once every 19 hours.

Asynchronous External Clock. A user-supplied external input clock can be used to pace the D/A, entirely independent of analog inputs.

Synchronous External Clock. A user-supplied external input clock can pace both the D/A and the analog input.

Digital I/O

Twenty-four TTL-level digital I/O lines are included in the [DaqBoard/3000USB](#) series. Digital I/O can be programmed in 8-bit groups as either inputs or outputs, and can be scanned in several modes (see Input Scanning). Ports programmed as inputs can be part of the scan group and scanned along with analog input channels, or can be asynchronously accessed via the PC at any time, including when a scanned acquisition is occurring. Two synchronous modes are supported when scanned along with ana-

log inputs. One mode is where the digital inputs are scanned at the start of each scan sequence, which means the rate at which they are scanned is dependent on the number of analog input channels, and the delay period. For example, if 8 analog inputs are enabled with 0 delay period, then the digital inputs in this mode would be scanned at once per 8 μ s, which is 125 kHz.

In the other synchronous mode, the enabled digital inputs are scanned synchronously with every analog input channel. So in the example above, the digital inputs would be scanned at once per μ s, or 1 MHz.

If no analog inputs are being scanned, the digital inputs can be scanned at up to 12 Msamples/s.

The low-latency digital output mode allows a digital output to be updated based on the level of an analog, digital, or counter input. In this mode, the user associates a digital output bit with a specific input, and specifies the level of the input where the digital output changes state. The response time in this mode is dependent on the number of input channels being scanned, and can typically be in the range of 2 to 6 μ s.

Pattern Generation

Two of the 8-bit ports can be used to generate a 16-bit digital pattern at up to 1 MHz. The digital pattern can be read from PC RAM or a file on the hard disk. Digital pattern generation is clocked in the same four modes as described with analog output.

Counter Inputs

Four 32-bit counters are built into the [DaqBoard/3000USB](#) series. Each of the four counters will accept frequency inputs up to 20 MHz, and each counter channel can be configured in a variety of modes including counter, period, pulse width, time between edges, or multi-axis quadrature encoder. The counters can concurrently monitor time periods, frequencies, pulses, and other event-driven incremental occurrences from encoders, pulse generators, limit switches, proximity switches, and magnetic pickups. As with all other inputs to the [DaqBoard/3000USB](#) series, the counter inputs can be read asynchronously under program control, or synchronously as part of an analog and digital scan group based either on an internal programmable timer, or an external clock source. The use of Z-channel encoders or usage of mapped channels requires that these channels need to be read synchronously.

The [DaqBoard/3000USB](#) supports quadrature encoders with up to 2 billion pulses per revolution, 20-MHz input frequencies, and x1, x2, x4 count modes. With only A phase and B phase signals, 2 channels are supported. With A phase, B phase, and Z index signals, 1 channel is supported. Each input can be debounced from 500 ns to 25.5 ms (total of 16 selections) to eliminate extraneous noise or switch induced transients. Encoder input signals must be within -15V to +15V and the switching threshold is TTL (1.3V).

Timer Outputs

Two 16-bit timer outputs are built into the [DaqBoard/3000USB](#), each capable of generating different square waves with a programmable frequency range from 16 Hz to 1 MHz.



DaqBoard/3000USB™ Series

Specifications

Voltage Range*	Accuracy ±(% of reading + % Range) 23°C ±10°C, 1 year	Temperature Coefficient ±(ppm of reading + ppm Range)/°C -30°C to 13°C and 33°C to 70°C	Noise** (cts RMS)
-10V to 10V	0.031% + 0.008%	14 + 8	2.0
-5V to 5V	0.031% + 0.009%	14 + 9	3.0
-2V to 2V	0.031% + 0.010%	14 + 10	2.0
-1V to 1V	0.031% + 0.02%	14 + 12	3.5
-500 mV to 500 mV	0.031% + 0.04%	14 + 18	5.5
-200 mV to 200 mV	0.036% + 0.05%	14 + 12	8.0
-100 mV to 100 mV	0.042% + 0.10%	14 + 18	14.0

* Specifications assume differential input single channel scan, 1-MHz scan rate, unfiltered, CMV=0.0V, 30 minute warm-up, exclusive of noise, range -FS to +FS

** Noise reflects 10,000 samples at 1-MHz, typical, differential short

Specifications

General

Power Consumption (per board)	
Model	Power Consumption (Typical)†
/3001USB	3000 mW
/3005USB	2000 mW
/3031USB	3400 mW
/3035USB	2400 mW

† An optional power adapter (TR-2) will be required if the USB port cannot supply adequate power. USB2 ports are, by USB2 standards, required to supply 2500 mW (nominal at 5V, 500 mA).

Environment

Operating Temperature: -30° to +70°C; Storage Temperature: -40° to +80°C

Relative Humidity: 0 to 95% non-condensing
Communications Speed: USB 2.0 high-speed mode (480 Mbps) if available, otherwise, USB1.1 full-speed mode (12 Mbps)

Acquisition Data Buffer: 1 MSample

Vibration: MIL STD 810E Category 1 and 10

Signal I/O Connectors: 68-pin standard "SCSI type III" female connector (P5); four 40-pin headers (J5, J6, J7, J8), AMP# 2-103328-0

Temperature Measurement Connector: 4-channel TC screw-terminal block (TB7); Phoenix # MPT 0.5/9-2.54;

External Power

Connector: Switchcraft#RAPC-712

Power Range: 6 to 16 VDC (used when USB port supplies insufficient power, or when an independent power supply is desired)

Over-Voltage: 200V for 10 seconds, max.

Physical Attributes:

Dimensions: 152.4 mm W x 150.62 mm D

(6.0" x 5.93")

Weight: 147 g (0.32 lbs)

Analog Inputs

Channels: 16 single-ended or 8 differential, programmable on a per-channel basis as single-ended or differential; 4 differential channels can be assigned to thermocouples

Over-Voltage Protection: ±30V without damage

Voltage Measurement Speed: 1 μs per channel

Ranges: Software or sequencer selectable on a per-channel basis, ±10V, ±5V, ±2V, ±1V, ±0.5V, ±0.2V, ±0.1V

Input Impedance: 10M Ohm single-ended; 20M Ohm differential

Total Harmonic Distortion: -80 dB, typical for ±10V range, 1 kHz fundamental

Signal to Noise and Distortion: 72 dB, typical for ±10V range, 1 kHz fundamental

Bias Current: 40 pA typical (0°C to 35°C)

Crosstalk: -75 dB typical DC to 60 Hz; -65 dB typical @ 10 kHz

Common Mode Rejection: -70 dB typical DC to 1 kHz

Maximum Usable Input Voltage + Common Mode Voltage††	
Ranges	Maximum (CMV + Vin)
0.5, 1, 2, 5, 10V	10.5V
0.1, 0.2V	2.1V

†† DaqBoard/3035USB and DaqBoard/3031USB each support a total of 64SE (or 32 differential) channels

TC Types and Accuracy¹

TC Type	Temperature Range (°C)	Accuracy (±°C)	Noise, Typical (±°C)
J	-200 to +760	1.7	0.2
K	-200 to +1200	1.8	0.2
T	-200 to +400	1.8	0.2
E	-270 to +650	1.7	0.2
R	-50 to +1768	4.8	1.5
S	-50 to +1768	4.7	1.5
N	-270 to +1300	2.7	0.3
B	+300 to +1400	3.0	1.0

1. Assumes 16384 oversampling applied, CMV = 0.0V, 60 minute warm-up, still environment, and 25°C ambient temperature; excludes thermocouple error; TC_N = 0°C for all types except B (1000°C), TR-2 for External Power.

A/D Specifications

Type: Successive approximation

Resolution: 16 bit

Maximum Sample Rate: 1 MHz

Nonlinearity (Integral): ±2 LSB maximum

Nonlinearity (Differential): ±1 LSB maximum

Input Sequencer

Analog, digital, and counter inputs can be scanned synchronously, based on either an internal programmable timer, or an external clock source. Analog and digital outputs can be synchronized to either of these clocks.

Scan Clock Sources: 2

Note: The maximum scan clock rate is the inverse of the minimum scan period. The minimum scan period is equal to 1 μs times the number of analog channels. If a scan contains only digital channels then the minimum scan period is 250 ns.

1. Internal, programmable

Analog Channels from 1 μs to 19 hours in 20.83 ns steps

Digital Channels and Counters from 250 ns to 19 hours in 20.83 ns steps

2. External, TTL level input

Analog Channels down to 1 μs min

Digital Channels and counters down to 250 ns min

Programmable Parameters per Scan: Channel (random order), gain

Depth: 512 locations

On-Board Channel-to-Channel Scan Rate:

Analog: 1-MHz maximum

Digital: 4 MHz if no analog channels are enabled, 1 MHz with analog channels enabled

External Acquisition Scan Clock Input

Maximum Rate: 990 kHz

Clock Signal Range: Logical zero 0V to 0.8V; logical one 2.4V to 5.0V

Minimum Pulse Width: 50 ns high, 50 ns low

Triggering

Trigger Sources: 7, individually selectable for starting and stopping an acquisition. Stop acquisition can occur on a different channel than start acquisition; stop acquisition can be triggered via modes 2, 4, 5, or 6 described below.

1. Single-Channel Analog Hardware Trigger

Any analog input channel can be software programmed as the analog trigger channel, including any of the analog expansion channels.

Input Signal Range: -10 to +10V max

Trigger Level: Programmable; 12-bit resolution

Hysteresis: Programmable; 12-bit resolution

Latency: 350 ns typ, 1.3 μs max

Accuracy: ±0.5% of reading, ±2 mV offset

Noise: 2 mV RMS

2. Single-Channel Analog Software Trigger

Any analog input channel, including any of the analog expansion channels, can be selected as the software trigger channel. If the trigger channel involves a calculation, such as temperature, then the driver automatically compensates for the delay required to obtain the reading, resulting in a maximum latency of one scan period.

Input Signal Range: Anywhere within the range of the selected trigger channel

Trigger Level: Programmable; 16-bit resolution, including "window triggering"

Latency: One scan period max

3. Single-Channel Digital Trigger

A separate digital input is provided for digital triggering.

Input Signal Range: -15V to +15V

Trigger Level: TTL

Minimum Pulse Width: 50 ns high, 50 ns low

Latency: 100 ns typ, 1.1 μs max



DaqBoard/3000USB™ Series

Specifications

4. Digital Pattern Triggering

8- or 16-bit pattern triggering on any of the digital input ports. Programmable for trigger on equal, above, below, or within/outside of a window. Individual bits can be masked for "don't care" condition.

Latency: One scan period max

5. Counter/Totalizer Triggering

Counter/totalizer inputs can trigger an acquisition. User can select to trigger on a frequency or on total counts that are equal, above, below, or within/outside of a window.

Latency: One scan period, max

6. Software Triggering

Trigger can be initiated under program control.

7. Multi-Channel Triggering

Up to 16 channels can be used to generate a trigger condition for any combination of analog, digital, or counter inputs. Multiple channels can either be combined in a logical "or" or "and" condition, with hysteresis programmable per channel. Maximum latency in this mode is one scan period.

Analog Outputs

(/3001USB and /3031USB models only)

Analog output channels are updated synchronously relative to scanned inputs, and clocked from either an internal clock, or an external clock source.

Analog outputs can also be updated asynchronously, independent of any other scanning in the system. Streaming from disk or memory is supported, allowing continuous waveform outputs (limited only by available PC system resources).

Channels: 4 DAC channels (DAC0, DAC1, DAC2, DAC3)

Resolution: 16 bits

Data Buffer: PC-based memory

Output Voltage Range: $\pm 10V$

Output Current: ± 1 mA max; sourcing more current (1 to 10 mA) may require a TR-2 power adapter option

Offset Error: $\pm 0.0045V$ max

Digital Feedthrough: < 10 mV when updated

DAC Analog Glitch: < 12 mV typical at major carry

Gain Error: $\pm 0.01\%$

Update Rate: 1 MHz max, 19 hours min (no minimum with external clock); resolution 20.83 ns

Settling Time: 2 μs to rated accuracy

Clock Sources: 4 programmable

1. Onboard D/A clock, independent of scanning input clock
2. Onboard scanning input clock
3. External D/A input clock, independent of external scanning input clock
4. External scanning input clock

Digital I/O

Channels: 24

Ports: 3 x 8-bit, each port is programmable as input or output

Input Scanning Modes: 2 programmable

1. Asynchronous, under program control at any time relative to input scanning
2. Synchronous with input scanning

Input Characteristics: 220 Ohm series resistor, 20 pF to common

Logic Keeper Circuit: Holds the logic value to 0 or 1 when there is no external driver.

Input Protection: ± 15 kV ESD clamp diodes parallel

Input Levels:

Low: 0 to 0.8V

High: +2.0V to +5.0V

Output Levels:

Low: $< 0.8V$

High: $> 2.0V$

Output Characteristics: Output 1.0 mA per pin; sourcing more current may require a TR-2 power adapter option

Sampling: 4-MHz maximum

Update Rate: 4-MHz maximum, 19 hours minimum (no minimum with external clock); resolution 20.83 ns

Pattern Generation Output

Two of the 8-bit ports can be configured for 16-bit pattern generation. The pattern can also be updated synchronously with an acquisition at up to 4 MHz.

Counter

Each of the four high-speed, 32-bit counter channels can be configured for counter, period, pulse width, time between edges, or multi-axis quadrature encoder modes. Counter inputs can be scanned synchronously along with analog and digital scanned inputs, based on an internal programmable timer, or an external clock source.

Channels: 4 x 32-bit

Input Frequency: 20-MHz max

Input Signal Range: -5V to +10V

Input Characteristics: 10K Ohm pull-up, 200 Ohm series resistor, ± 15 kV ESD protection

Trigger Level: TTL

Minimum Pulse Width: 25 ns high, 25 ns low

Debounce Times: 16 selections from 500 ns to 25.5 ms; positive or negative edge sensitive; glitch detect mode or debounce mode

Time Base Accuracy: 50 ppm (0° to $50^\circ C$)

Five Programmable Modes: Counter, Period, Pulsewidth, Timing, Encoder

Counter Mode Options: Totalize, Clear on Read, Rollover, Stop at all Fs, 16- or 32-bit, any other channel can gate or decrement the counter

Period Mode Options: Measure x1, 10, 100, or 1000 periods, 16- or 32-bit, time bases to choose from: 20.83 ns, 208.3 ns, 2.083 μs , 20.83 μs , any other channel can gate the period measurement

Pulsewidth Mode Options: 16- or 32-bit values, 4 time bases to choose from: 20.83 ns, 208.3 ns, 2.083 μs , 20.83 μs , any other channel can gate the pulsewidth measurement

Timing Mode Options: 16- or 32-bit values, 4 time bases to choose from: 20.83 ns, 208.3 ns, 2.083 μs , 20.83 μs

Encoder Mode Options: x1, 2, 4 options, 16- or 32-bit values, Z-channel clearing of counter, any other channel can gate the counter

Multi-axis Quadrature Encoder Inputs:

- 1 channel with A (phase), B (phase) and Z (index)
- 2 channel with A (phase) and B (phase)
- x1, x2, and x4 count modes
- Single-ended TTL

Frequency/Pulse Generators

Channels: 2 x 16-bit

Output Waveform: Square wave

Output Rate: 1-MHz base rate divided by 1 to 65535 (programmable)

High-Level Output Voltage: 2.0V min @ -1.0 mA; 2.9V min @ -400 μA

Low-Level Output Voltage: 0.4V max @ 400 μA



DaqBoard/3000USB™ Series

Ordering Information

Ordering Information

Description	Part No.
16-bit, 1-MHz USB data acquisition board with 16 analog inputs, 4 of which are capable of measuring thermocouples or voltage, 24 digital I/O, 4 counters, 2 timers; includes DaqView and DaqCal software; support for Visual Studio® and Visual Studio® .NET; plus drivers for DASyLab®, LabVIEW®, and MATLAB®	DaqBoard/3005USB
Same as /3005USB but with four 16-bit, 1-MHz analog outputs	DaqBoard/3001USB
Same as /3005USB but with 64 analog inputs	DaqBoard/3035USB
Same as /3005USB but with 64 analog inputs and four 16-bit, 1-MHz analog outputs	DaqBoard/3031USB

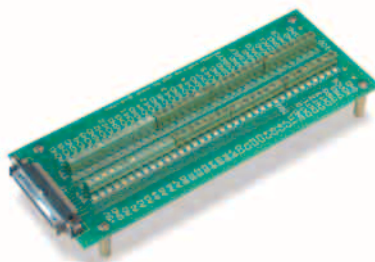

The **DBK215** provides 16 BNC connectors plus internal screw-terminal connections

TB-100, termination board with screw terminals, provides access to DaqBoard/3000USB series I/O. The TB-100 can be panel mounted or 19" rack mounted using optional Rack3.

Accessories & Cables

Termination board with screw-terminals for access to DaqBoard/3000USB series I/O; connects via a CA-G55, CA-G56, or CA-G56-6 cable	TB-100
Termination board with screw terminals for access to DaqBoard/3000USB series I/O; mates directly with DaqBoard and includes mounting stand-offs	TB-101
External power supply	TR-2
Rack-mount kit for TB-100	Rack3
BNC termination module with 16 BNC connectors and internal screw-terminal connections; connects via a CA-G55, CA-G56, or CA-G56-6 cable	DBK215
68-conductor ribbon expansion cable from DaqBoard/3000 series boards to TB-100, or DBK215, 3 ft.	CA-G55
68-conductor shielded cable from DaqBoard/3000 series boards to TB-100, or DBK215, 3 ft.	CA-G56
68-conductor shielded cable from DaqBoard/3000 series boards to TB-100, or DBK215, 6 ft.	CA-G56-6
USB cable, 1 meter	CA-179-1
USB cable, 3 meters	CA-179-3
USB cable, 5 meters	CA-179-5
Ribbon cable, 40-pin header to 37-pin DSUB, 9 in.	CA-248

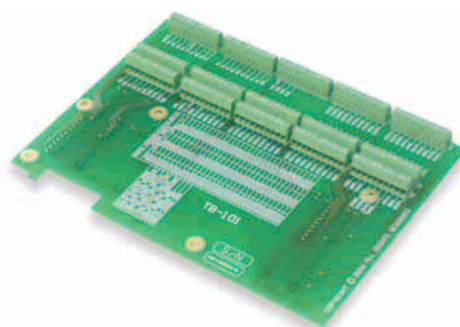

CA-G55, 68-conductor low-cost cable

TB-101, termination board with screw terminals, provides access to all DaqBoard/3000USB series I/O. The TB-101 mounts directly onto the DaqBoard with included hardware.



CA-G56, 68-conductor shielded cable



CA-248, 40-pin header to male DB-37

Software

DaqView add-on for seamless execution with Microsoft Excel's tool palette	DaqViewXL/Plus
DaqView add-on includes all of the features of DaqViewXL/Plus, plus frequency-domain analysis	DaqView/Pro
Icon-based data acquisition, graphics, control, and analysis software	DASyLab

Related Products

DaqBoard/3000 Series
 Personal Daq/3000 Series
 DASyLab

Contact IOtech today for all your USB needs!

1-888-714-3272

www.iotech.com

sales@iotech.com