

DaqBoard/500™ Series

16-Bit, 200-kHz PCI Data Acquisition Boards

Features

- Low price, 16-bit PCI DaqBoards
- 16-bit, 200-kHz A/D converter
- 8 differential or 16 single-ended analog inputs (software selectable per-channel)
- Up to four boards can be installed into one PC
- 100% digital calibration
- DMA bus mastering
- Trigger modes include digital and software, with <math>< 5 \mu\text{s}</math> latency
- Virtually infinite pre-trigger buffer
- Two 16-bit, 100-kHz analog outputs with continuous waveform output capability (model /500 only)
- 24 digital I/O lines
- One counter/pulse input channel
- Two timer/pulse output channels

Software

- Includes DaqView™ *Out-of-the-Box*™ software application for effortless data logging and analysis
- Support for Visual Studio® and Visual Studio® .NET, including examples for Visual C++®, Visual C#®, Visual Basic®, and Visual Basic® .NET
- Comprehensive drivers for DASyLab®, and LabVIEW®
- Support for Windows® 2000 and XP

The new DaqBoard/500™ and /505 are the lowest priced, 16-bit/200-kHz data acquisition boards. Each board offers sixteen channels of 16-bit analog inputs, 24 digital I/O lines, and one counter input. The DaqBoard/500 also provides two 16-bit waveform capable analog outputs.

Software support for the DaqBoard/500 series includes support for Visual Studio® and Visual Studio® .NET, including examples for Visual C++®, Visual C#®, Visual Basic®, and Visual Basic® .NET, plus comprehensive drivers for DASyLab®, and LabVIEW®. Also included is DaqView *Out-of-the-Box*™ software for quick and easy set up and collection of data without programming.

Signal I/O

One 68-pin connector on the DaqBoard/500 series provides access to all of the input and output signals. Unlike other multi-function boards that require multiple PC

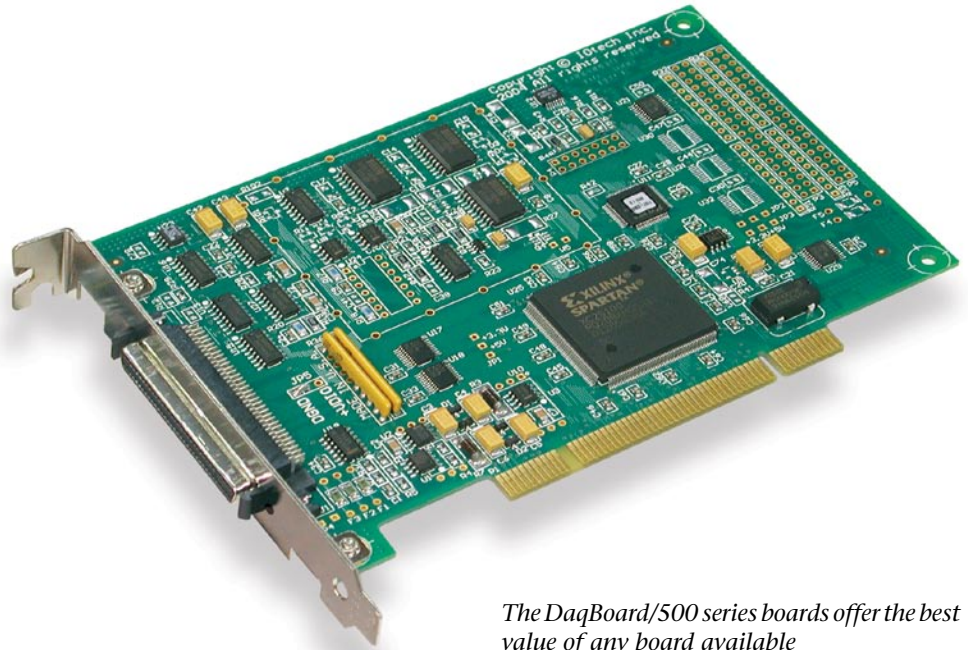

The DaqBoard/500 series boards offer the best value of any board available

slots in order to access all of the I/O, the DaqBoard/500 series accommodates all I/O using one cable, and utilizing a single PCI slot. The latching 68-pin I/O connector contains all analog input channels plus digital I/O lines, counter input, timer outputs and analog outputs.

Analog Input

The DaqBoard/500 series has a 16-bit, 200-kHz A/D coupled with 16 single-ended, or 8 differential analog inputs. Eight software programmable ranges provide inputs from $\pm 10\text{V}$ to $\pm 1.25\text{V}$ full scale. Each channel can be software-configured for a different range, as well as for single-ended or differential and bipolar or unipolar input.

Bus Mastering DMA

The DaqBoard/500 series supports Bus Mastering DMA, which allows analog input data, as well as analog and digital output data to flow between the PC and the DaqBoard/500 series without consuming valuable CPU time. The driver supplied with the DaqBoard/500, as well as all other third-party software support such as LabVIEW®, automatically utilize Bus Mastering DMA to efficiently conduct I/O from the PC to the DaqBoard.

Triggering

The DaqBoard/500 series supports several trigger modes to accommodate any measurement situation.

Digital. A separate digital trigger input line is provided, allowing TTL-level triggering, again with latencies guaranteed to be less than $5 \mu\text{s}$. The edge (rising or falling), can be programmed for the discrete digital trigger input.

Software-Based Channel Level Triggering. Software-based Channel Level triggering differs from the mode described above because the readings, analog, digital, or counter are interrogated by the PC to detect the trigger event, not in the hardware as described above.

Normally software-based triggering results in long latencies from the time that a trigger condition is detected, until the actual capturing of data commences. However, the DaqBoard/500 series circumvents this undesirable phenomenon by use of pre-trigger data. Specifically, when software-based triggering is employed, and the PC detects that a trigger condition has occurred, (which may be thousands of readings later than the actual occurrence

DaqBoard/500™ Series

General Information

of the signal), the DaqBoard driver automatically looks back to the location in memory where the actual trigger-causing measurement occurred. The acquired data that is presented to the user actually begins at the point where the trigger-causing measurement occurs. The latency in this mode is equal to one scan cycle.

Stop Trigger. Any of the software trigger modes described above can also be used to stop an acquisition. Thus an acquisition can be programmed to begin on one event, such as a voltage level, and then can stop on another event.

Pre- and Post-Triggering Modes. Six modes of pre- and post-triggering are supported, providing a wide variety of options to accommodate any measurement requirement. When using pre-trigger, the user must use software-based triggering to initiate an acquisition.

No pre-trigger, post-trigger stop event. This, the simplest of modes, acquires data upon receipt of the trigger, and stops acquiring upon receipt of the stop-trigger event.

Fixed pre-trigger with post-trigger stop event. In this mode, the user specifies the number of pre-trigger readings to be acquired, after which, acquisition continues until a stop-trigger event occurs.

No pre-trigger, infinite post-trigger. No pre-trigger data is acquired in this mode. Instead, data is acquired beginning with the trigger event, and is terminated when the operator issues a command to halt the acquisition.

Fixed pre-trigger with infinite post-trigger. The user specifies the amount of pre-trigger data to acquire, after which the system continues to acquire data until the program issues a command to halt acquisition.

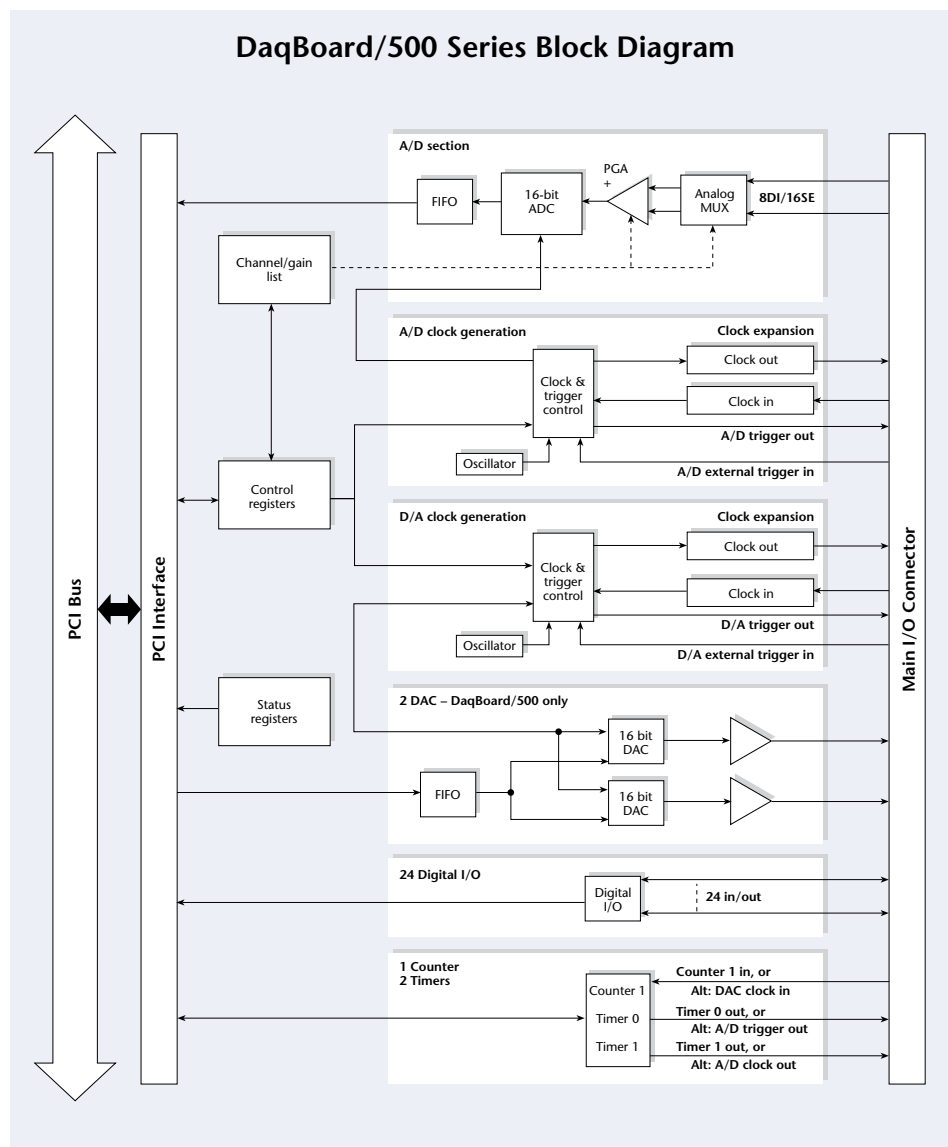

Variable pre-trigger with post-trigger stop event*. Unlike the previous pre-trigger modes, this mode does not have to satisfy the pre-trigger number of readings before recognizing the trigger event. Thus the number of pre-trigger readings acquired is variable and dependent on the time of the trigger event relative to the start. In this

mode, data continues to be acquired until the stop trigger event is detected.

Variable pre-trigger with infinite post-trigger*. This is similar to the mode described previously, except that the acquisition is terminated upon receipt of a command from the program to halt the acquisition.

* Driver support only

DaqBoard/500™ Series

General Information

Calibration

Every range on the DaqBoard/500 series is calibrated from the factory using a digital calibration method. This method works by storing a correction factor for each range on the DaqBoard/500 series at the time of calibration. Whenever a particular range is selected, the appropriate calibration constant is automatically applied, thereby calibrating the specific range.

Analog Output DaqBoard/500

Two 16-bit, 100-kHz analog output channels are built into the DaqBoard/500, with software selectable output ranges of $\pm 10V$ and 0-10V. Through the use of Bus Mastering DMA, each D/A output can continuously output a waveform. In addition, a program can asynchronously output a value to either of the D/As for non-waveform applications, presuming that the D/A is not already being used in the waveform output mode.

When used to generate waveforms, the D/As can be clocked in several different modes as described below.

Asynchronous Internal Clock. The on-board programmable clock can generate updates ranging from 0.0009 Hz to 100 kHz, independent of any acquisition rate.

Asynchronous External Clock. A user-supplied external input clock can be used to pace the D/A, entirely independent of analog inputs.

Digital Inputs and Outputs

Twenty four TTL-level digital I/O lines are included in the DaqBoard/500 series. They are divided into three 8-bit ports. Ports can be programmed as either input or output.

Counter Inputs

One 16-bit counter is built into the DaqBoard/500 series, capable of counting up to 65,536 TTL-level transitions. The counter will accept frequency inputs up to 900 kHz.

Timer Outputs

Two 16-bit timer outputs are included in the DaqBoard/500 series, each capable of generating square waves with a programmable frequency range from 7.7 Hz to 500 kHz.

Multiple DaqBoards per PC

All of the features described for the DaqBoard/500 series can be replicated with up to four DaqBoards installed in the same PC. When multiple boards are installed, all boards can be operated synchronously.

The TB-100™ screw-terminal board (shown below) makes it easy for the user to attach signals to the DaqBoard/500 series boards.

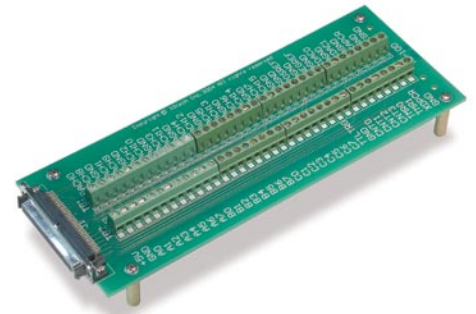

The TB-100, termination board with screw terminals, provides access to all DaqBoard/500 series I/O. The TB-100 can be panel mounted or 19" rack mounted using optional Rack3.

DaqBoard/500™ Series

Specifications & Ordering Information

Specifications

General (all boards)

Power Consumption (per board): 2W
Operating Temperature: 0° to +60°C
Vibration: MIL STD 810E Category 1 and 10
Signal I/O Connector: 68-pin SCSI type III female connector carries all analog and digital I/O signals
Dimensions: 165 mm W x 15 mm D x 108 mm H (6.5" x 0.6" x 4.2")

Analog Inputs

Channels: 16 single-ended or 8 differential, programmable on a per-channel basis as single-ended or differential and bipolar or unipolar
Bandwidth: 500 kHz
Settling Time: See table below
Over-Voltage Protection: ±25V
Ranges: Software or sequencer selectable on a per-channel basis
Input Impedance: 10M Ohm

Voltage Range	Accuracy one year, 18 to 28°C, excluding noise, % of full range	Settling Time
0 to +10V	±0.06%	5 µs
0 to +5V	±0.08%	5 µs
0 to +2.5V	±0.1%	20 µs
0 to +1.25V	±0.12%	20 µs
-10V to +10V	±0.04%	5 µs
-5V to +5V	±0.06%	5 µs
-2.5V to +2.5V	±0.08%	20 µs
-1.25V to +1.25V	±0.1%	20 µs

A/D Specifications

Type: Successive approximation
Resolution: 16 bit
Conversion Time: 5 µs
Maximum Sample Rate: 200 kHz
Nonlinearity (Integral): ±1 LSB
Nonlinearity (Differential): ±3 LSB, No missing codes

Input Sequencer

Analog inputs can be scanned based on either an internal programmable timer, or an external clock source.
Scan Clock Sources: 2
 1. Internal
 2. External, TTL level input up to 200 kHz max
Programmable Parameters per Scan: Channel (random order), gain
Depth: 176 location
On-Board Channel-to-Channel Scan Rate: 5 µs per channel

External Acquisition Scan Clock Input

Maximum Rate: 200 kHz
Clock Signal Range: 0V to +5V
Minimum Pulse Width: 50 ns high, 50 ns low



CA-G56, 68-conductor shielded expansion cable

Triggering

Trigger Sources: 3, individually selectable for starting and stopping an acquisition. Stop acquisition can occur on a different trigger source other than start acquisition, and can be triggered via modes 1 or 3. Pre-trigger is supported with fixed or variable pre-trigger periods.

1. Single-Channel Analog Software Trigger
Latency: One scan period max
2. Single-Channel Digital Trigger
Latency: 5 µs max
3. Software Triggering
Trigger can be initiated under program control.

Analog Outputs (/500 only)

The two analog output channels are updated asynchronously relative to scanned inputs, and clocked from either an internal onboard clock, or an external clock source. Analog outputs can be updated asynchronously, independent of any other scanning in the system. Bus Mastering DMA provides CPU and system-independent data transfers, ensuring accurate outputs independent of other system activities. Output from memory is supported, allowing continuous waveform outputs.

Channels: 2
Resolution: 16 bits
Conversion Time: 10 µs
Output Voltage Ranges: ±10V or 0-10V (software selectable)
Offset Error: ±0.0045V max
Gain Error: ±0.01% of full range
Digital Feedthru: 50 mV when updated
Clock Sources: 2, programmable
 1. Onboard D/A clock, independent of scanning input clock
 2. External D/A input clock, independent of external scanning input clock

Digital I/O

Channels: 24
Ports: 3 x 8-bit. Each 8-bit port is software programmable as input or output
Input Characteristics: 100 Ohm series, 20 pF to common, 4.7k Ohm pull-ups
I/O Levels: TTL
Output Characteristics: Output 24 mA per pin (sink-ing and sourcing)

Counter

One 16-bit counter is built into the DaqBoard/500 series capable of counting up to 65,536 TTL-level transitions.
Channels: 1 x 16-bit
Frequency Measurement Rate: 900 kHz max
Trigger Level: TTL

Frequency/Pulse Generators

Channels: 2 x 16-bit
Output: 500 kHz base rate divided by 1 to 65,535 (programmable)

BUY NOW!

For complete product specifications, pricing, and accessory information, call 1-888-714-3272 (U.S. only) or visit iotech.com.

Ordering Information

Description	Part No.
16-bit, 200-kHz data acquisition board for PCI-bus PCs with 16 analog inputs, two 16-bit, 100-kHz analog outputs, 24 digital I/O, one 16-bit counter-timer, and two 16-bit frequency/pulse generators; includes DaqView software; support for Visual Studio® and Visual Studio® .NET, plus comprehensive drivers for DASyLab®, and LabVIEW®	DaqBoard/500
Same as DaqBoard/500 but with no analog outputs	DaqBoard/505

Accessories & Cables

16-conductor BNC connection module with internal screw-terminal connections for use with DaqBoard/500, or /1000 series	DBK215
Termination board with screw terminals for access to all DaqBoard/500 series I/O; connects via CA-G55 or CA-G56 cable	TB-100
Rack-mount kit for TB-100	Rack3
68-conductor ribbon expansion cable, mates with the DaqBoard/500 series boards and the TB-100, 3 ft.	CA-G55
68-conductor shielded expansion cable, mates with the DaqBoard/500 series boards and the TB-100, 3 ft.	CA-G56
68-conductor shielded expansion cable, mates with the DaqBoard/500 series boards and the TB-100, 6 ft.	CA-G56-6

Software

DaqView add-on for seamless execution with Microsoft Excel's tool palette	DaqViewXL/Plus
DaqView add-on includes all of the features of DaqViewXL/Plus, plus frequency-domain analysis	DaqView/Pro
Icon-based data acquisition, graphics, control, and analysis software	DASyLab



The DBK215 provides 16 BNC inputs or outputs, and internal screw-terminal connections



CA-G55, 68-conductor expansion cable