

DaqBoard/3000™ Series

PCI 1-MHz, 16-Bit Multifunction Boards

Features

- Four low-cost, 1-MHz, 16-bit multi-function PCI boards
- 8 differential or 16 single-ended analog inputs (software selectable per channel)
- User-expandable up to 64SE/32DE analog inputs including thermocouple measurements
- Four 16-bit, 1-MHz analog outputs with continuous waveform capability
- 24 high speed digital I/O lines
- Four 32-bit counter input channels with quadrature encoder capability
- Ultra low-latency control output capability (as low as 2 μ s latency)
- Multiple DMA channels

Software

- Includes DaqView™ Out-of-the-Box™ software for instant set-up, real-time viewing, data logging, and optional frequency domain analysis
- Support for Visual Studio® and Visual Studio® .NET, including examples for Visual C++®, Visual C#®, Visual Basic®, and Visual Basic® .NET
- Comprehensive drivers for DASyLab®, LabVIEW®, and MATLAB®
- DaqCal™ software application for easy user calibration

The new DaqBoard/3000™ series from IOtech continues our tradition of offering the best price/performance PCI boards in the industry. The new DaqBoard/3000 series is no exception, offering 16-bit/1-MHz multifunction, synchronous I/O at substantially lower prices. This is accomplished by incorporating a high level of integration, while focusing on features that provide valuable benefits to users.

The new DaqBoard/3000 series feature a 16-bit/1-MHz A/D converter, 16 analog input channels – user expandable to 64, up to four 16-bit/1-MHz analog outputs, 24 high-speed digital I/O, 2 timer outputs, and four 32-bit counters. All analog I/O, digital I/O, and counter/timer I/O can operate synchronously and simultaneously, guaranteeing deterministic I/O timing amongst all signal types. Also unique to the DaqBoard/3000 series is a high-speed, low-latency, highly deterministic control output mode that operates independent of

OEMs: Contact IOtech if you require a custom version of this board with either PCI or USB

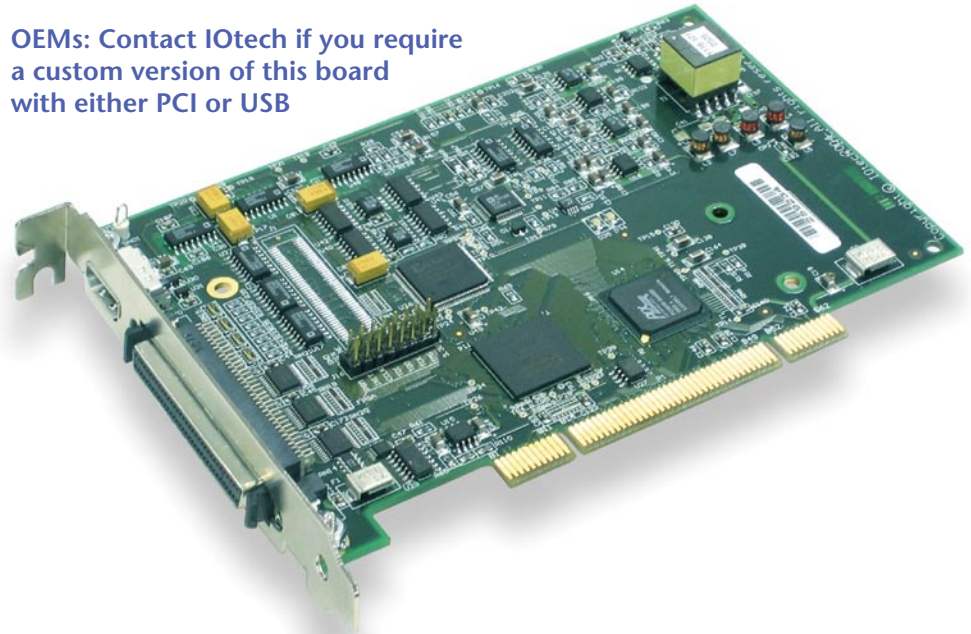

The DaqBoard/3000 series provides 1-MHz sampling, synchronous multifunction I/O, analog input expansion capability, and extensive software support

DaqBoard/3000 Series Selection Chart and PDQ30 Expansion Capabilities					
Product or System	Analog Inputs	Input Ranges	Digital I/O	Analog Outputs	Counters/Timers
DaqBoard/3006	16SE	1	24	0	4/2
DaqBoard/3005	16SE/8DE	7	24	0	4/2
DaqBoard/3000	16SE/8DE	7	24	2	4/2
DaqBoard/3001	16SE/8DE	7	24	4	4/2
DaqBoard/3005 + PDQ30	64SE/32DE	7	24	0	4/2
DaqBoard/3000 + PDQ30	64SE/32DE	7	24	2	4/2
DaqBoard/3001 + PDQ30	64SE/32DE	7	24	4	4/2

the PC. In this mode both digital and analog outputs can respond to analog, digital, and counter inputs as fast as 2 μ s; at least 1,000 times faster than most other boards that rely on the PC for decision making.

Other Hardware Features Include:

- Encoder measurements up to 20 MHz, including Z-channel zeroing
- Frequency and pulse-width measurements with 20.83 ns resolution
- Timing mode that can measure the time between two counter inputs to 20.83 ns resolution
- Self-calibration

For OEMs and embedded users who prefer the same functionality but USB-based vs PCI, see our DaqBoard/3000USB™ product offering. For end-users who would prefer the same functionality but with a USB module, see our Personal Daq/3000™ series.

Software

Software support for the DaqBoard/3000 series includes support for Visual Studio® and Visual Studio® .NET, including examples for Visual C++®, Visual C#®, Visual Basic®, and Visual Basic® .NET, plus comprehensive drivers for DASyLab®, LabVIEW®, and MATLAB®. Also included is DaqView Out-of-the-Box™ software for quick and easy set up and collection of data without programming, along with DaqCal™ software application for easy user calibration.

Also included with the DaqBoard/3000 series is new DaqView™ software, a comprehensive Out-of-the-Box™ application that enables set-up, data logging, and real-time data viewing without any programming skills. Optional DaqView/Pro also adds features such as direct-to-Excel® enhancements, FFT analysis, statistics, etc., all for a small additional price.

DaqBoard/3000™ Series

General Information

Support

IOtech offers unlimited free technical support for DaqBoard purchasers. Other vendors place a limit on support or require expensive service contracts, while IOtech provides free access to hardware and software engineers to assist you in developing your application and using your IOtech product.

Signal Connections

One 68-pin connector provides access to the 16SE/8DE analog input channels, 24 digital I/O lines, 6 counter/timer channels, and up to 4 analog outputs on each DaqBoard/3000 series board.

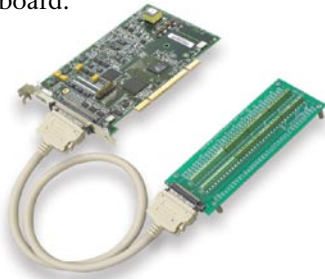

DaqBoard/3000 attached to a TB-100 terminal board

An externally accessible HDMI connector is also provided on the DaqBoard/3000 series, enabling a simple connection for the optional PDQ30 analog channel expansion module.



DaqBoard/3000 attached to a PDQ30 expansion module

In addition to standard screw-terminal options for the 3000 series, we also offer the DBK215 BNC connection module that provides screw-terminal access to all I/O, plus 16 BNC connectors that can be user configured.



DaqBoard/3000 attached to a DBK215 BNC and screw-terminal module

Analog Input

The DaqBoard/3000 series has a 16-bit, 1-MHz A/D coupled with 16 single-ended, or 8 differential analog inputs. Seven software programmable ranges provide inputs from $\pm 10V$ to ± 100 mV full scale*. Each channel can be software-configured for a different range, as well as for single-ended or differential bipolar input.

Analog Channel Expansion

Adding additional analog input channels for the DaqBoard/3000 series is easy using the optional PDQ30 expansion module. The PDQ30 connects to the DaqBoard/3000 series card via a CA-266-x cable and does not consume a PCI slot. The PDQ30 provides an additional 48SE/24DE analog inputs or 24 thermocouple inputs, software configured on a per channel basis. The total channel capacity with a PDQ30 attached is 64 single ended or 32 differential inputs. The measurement speed of PDQ30 channels is the same 1 Msample/s as with on-board channels. When configured to measure thermocouple channels the system sample rate is 10 kHz per channel. This reduction in sample rate insures that temperature measurements are accurate, low noise, and stable. The DaqBoard/3000

series also supports up to four boards installed into one PC, effectively quadrupling the number of channels that can be attached to one PC.

Synchronous I/O

The DaqBoard/3000 series can make analog measurements and read digital and counter inputs, while synchronously generating up to four analog outputs as well as digital pattern outputs. Additionally, digital and counter inputs do not affect the overall A/D rate because they use no time slot in the scanning sequencer. For example, one analog input channel can be scanned at the full 1-MHz A/D rate along with digital and counter input channels. The 1-MHz A/D rate is unaffected by the additional digital and counter channels. Many other data acquisition boards provide no capability to scan digital/counter channels along with analog channels, in which case digital and counter channels must be read asynchronously, which leads to a non-deterministic collection of data.

Input Scanning

The DaqBoard/3000 has several scanning modes to address a wide variety of applications. A 512 location scan buffer can be loaded by the user with any combination of analog input channels. All analog input channels in the scan buffer are measured sequentially at 1 μ s per channel. The user can also specify that the sequence repeat immediately, or repeat after a programmable delay from 0 to 19 hours, with 20.83 ns resolution. For example, in the fastest mode, with a 0 delay, a single analog channel can be scanned continuously at 1 Msamples/s; two analog channels can be scanned at 500 Ksamples/s each; 16 analog input channels can be scanned at 62.5 Ksamples/s.

DaqBoard/3000 digital inputs and counter inputs can be read in several modes. First, via software the digital inputs or counter inputs can be read asynchronously at anytime before, during, or after an analog input scan sequence. This mode is not deterministic as to exactly when the digital or counter input was read relative to an analog input channel.

* Single-ended $\pm 10V$ range on DaqBoard/3006

DaqBoard/3000™ Series

General Information

DaqBoard/3000 Series Block Diagram

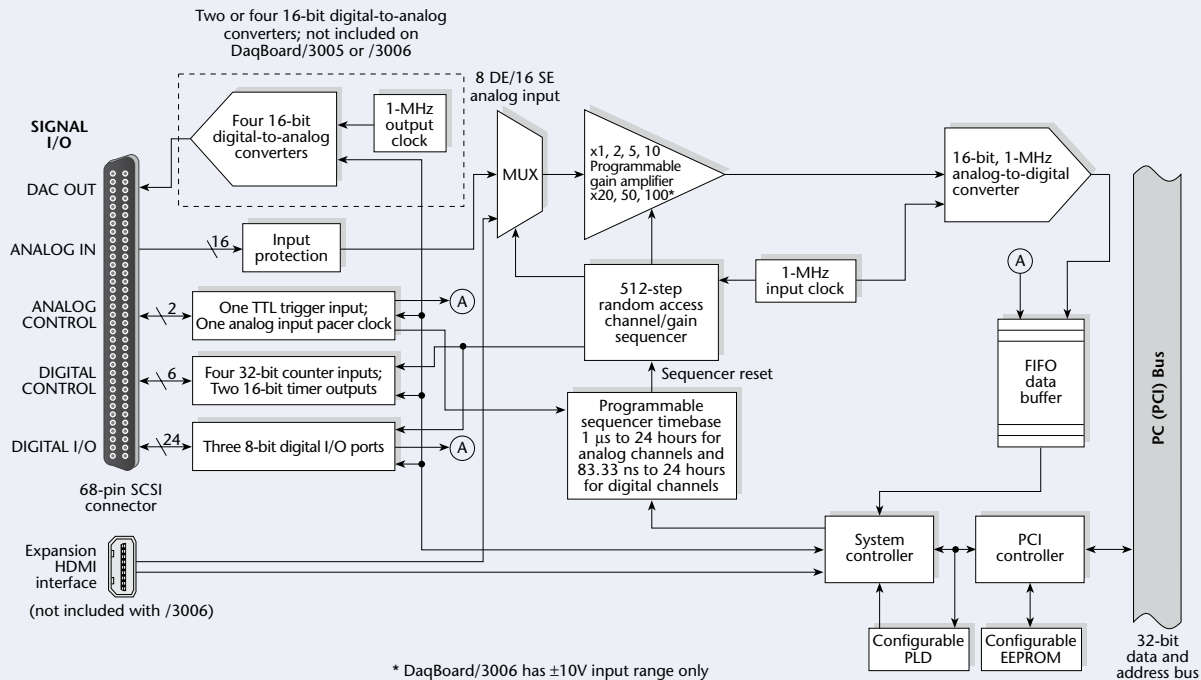

In either of the two synchronous modes, the digital inputs and/or counter inputs are read with deterministic time correlation to the analog inputs. In the once-per-scan mode, all of the enabled digital inputs and counter inputs are read during the first analog measurement of an analog input scan sequence. The advantage of this mode as compared to most other boards is the digital and counter inputs do not consume an analog input time slot, and therefore do not reduce the available bandwidth for making analog input measurements. For example, presume all 24 bits of digital input are enabled, and all four 32-bit counters are enabled, and eight channels of analog inputs are in the scan sequence at the full 1 μs/channel rate. At the beginning of each analog input scan sequence, which would be 8 μs in total duration, all digital inputs and counter inputs will be measured and sent to the PC during the first μs of the analog scan sequence.

Another synchronous mode is where digital inputs are scanned every time an analog input channel is scanned. For example, if eight analog inputs are scanned at 1 μs per

channel continuously, and 24 bits of digital inputs are enabled, then the 24 bits of digital inputs will be scanned at 24 bits per 1 μs. If counters are enabled in this mode, they will be scanned at once per scan, in the same manner as in the prior example.

Output Timing

The digital and analog outputs on the DaqBoard/3000 can be updated asynchronously or synchronously in several modes. In the asynchronous mode, digital, and analog outputs can be updated at anytime before, during or subsequent to an analog input sequence. The maximum update rate in this mode is non-deterministic and entirely dependent on the PC processor speed, the operating system, and programming environment.

In the synchronous output modes, the outputs can be updated directly from memory in the PC, or as the direct result of an input from either an analog channel, digital channel, or counter channel. When updated from memory in the PC (via DMA), the user can specify the rate by which the

output is updated in 20.83 ns intervals, and all outputs can be updated synchronously at a maximum rate of 1 μs. For example, all four 16-bit analog outputs can be generating different waveforms from PC memory with a 1 μs per channel update rate, while up to 16 bits of digital pattern could be generated from PC memory concurrently at the 1 μs per 16-bit update rate. Outputs can also be specified to update concurrently with inputs, so there is an exact timing correlation between inputs and outputs.

The other synchronous method of output control is where an output, either digital or analog, is associated with any input – analog, digital or counter. The state or level of the output is determined by the level or state of an associated input. For example, a digital output could be programmed to be a logic 1 when an analog input exceeds a certain value, or when a frequency input exceeds a certain rate. In addition, hysteresis can be programmed for each limit to insure the output is stable near the transition point. Up to 8 digital outputs and 4 analog outputs can be programmed to respond to any analog,

DaqBoard/3000™ Series

General Information

digital or counter input. When analog or digital outputs are used in this mode, the user can specify two output values, determined by whether the input is above or below the limit.

The slowest rate by which an analog output can respond to an input is 4 μ s plus the time period of a scan sequence. For example, if 4 channels of analog input are scanned continuously at 4 μ s per scan, then the maximum latency between an analog input satisfying a limit, and the output responding, is 4 + 4 or 8 μ s max. The worst-case response time can also be improved in several ways. For example, if a digital output is correlated to a digital input, then the worst-case latency can be reduced to 2 μ s total if all digital inputs are scanned at the 1 μ s rate without a delay period at the end of each scan.

In addition, an output status channel can be specified in the input scan sequence buffer so that users can correlate output state changes to their respective input channels within their data buffers and files. Adding the status channel takes no additional scan time and has no effect on the overall acquisition rate. The status channel can also be read asynchronously at any time during an acquisition for monitoring of the control outputs.

The advantage of this mode as compared to other boards is the response time can be in the range of 2 to 20 μ s, vs. 1000 or more microseconds when using other supplier's boards.

Triggering

The DaqBoard/3000 series supports a full complement of trigger modes to accommodate any measurement situation.

Hardware Analog Triggering. The DaqBoard/3000 series uses true analog triggering, whereby the trigger level programmed by the user sets an analog DAC, which is then compared in hardware to the analog input level on the selected channel. The result is analog trigger latency which is guaranteed to be less than 1 μ s, significantly shorter than most data acquisition

boards. Any analog channel can be selected as the trigger channel, including PDQ30 expansion channels. The user can program both the trigger level, as well as the edge (rising or falling) and hysteresis.

Digital Triggering. A separate digital trigger input line is provided, allowing TTL-level triggering with latencies guaranteed to be less than 1 μ s. Both the logic levels (1 or 0), as well as the edge (rising or falling), can be programmed for the discrete digital trigger input.

Pattern Triggering. The user can specify a 16-bit digital pattern to trigger an acquisition, including the ability to mask or ignore specific bits.

Software-Based Channel Level Triggering. This mode differs from the modes described previously because the readings, analog, digital, or counter, are interrogated by the PC in order to detect the trigger event. Triggering can also be programmed to occur when one of the counters reaches, exceeds, or is within a programmed window. Any of the built-in counter/totalizer channels can be programmed as a trigger source. Triggers can be detected on scanned digital input channel patterns as well.

Normally software-based triggering results in long latencies from the time that a trigger condition is detected, until the actual capturing of data commences. However, the DaqBoard/3000 series circumvents this undesirable situation by use of pre-trigger data. Specifically, when software-based triggering is employed, and the PC detects that a trigger condition has occurred, (which may be thousands of readings later than the actual occurrence of the signal), the DaqBoard driver automatically looks back to the location in memory where the actual trigger-causing measurement occurred. The acquired data that is presented to the user actually begins at the point where the trigger-causing measurement occurs. The maximum latency in this mode is equal to one scan period.

Stop Trigger. Any of the software trigger modes described previously including scan count can also be used to stop an

acquisition. Thus an acquisition can be programmed to begin on one event, such as a voltage level, and then can stop on another event, such as a digital pattern.

Pre- and Post-Triggering Modes. Six modes of pre- and post-triggering are supported, providing a wide variety of options to accommodate any measurement requirement. When using pre-trigger, the user must use software-based triggering to initiate an acquisition.

No pre-trigger, post-trigger stop event. This mode acquires data upon receipt of the trigger, and stops acquiring upon receipt of the stop-trigger event.

Fixed pre-trigger with post-trigger stop event. In this mode the user specifies the number of pre-trigger readings to be acquired, after which acquisition continues until a stop-trigger event occurs.

No pre-trigger, infinite post-trigger. No pre-trigger data is acquired in this mode. Instead, data is acquired beginning with the trigger event, and is terminated when the operator issues a command to halt the acquisition.

Fixed pre-trigger with infinite post-trigger. The user specifies the amount of pre-trigger data to acquire, after which the system continues to acquire data until the program issues a command to halt acquisition.

Variable pre-trigger with post trigger stop event*. Unlike the previous pre-trigger modes, this mode does not have to satisfy the pre-trigger number of readings before recognizing the trigger event. Thus the number of pre-trigger readings acquired is variable and dependent on the time of the trigger event relative to the start. In this mode, data continues to be acquired until the stop trigger event is detected.

Variable pre-trigger with infinite post-trigger*. This mode is similar to the mode described above, except that the acquisition is terminated upon receipt of a command from the program to halt the acquisition.

* Driver support only

DaqBoard/3000™ Series

General Information

Calibration

Every range on the DaqBoard/3000 is calibrated from the factory using a digital NIST traceable calibration method. This method works by storing a correction factor for each range on the unit at the time of calibration. The user can adjust the calibration of the board while in their system, without destroying the factory calibration supplied with the board. This is accomplished by having three distinct calibration tables in the DaqBoard/3000 series on-board EPROM, one which contains the factory cal, and two which are available for user calibration. The user can select any of the three cal tables provided: factory, user, or self-cal tables by API call, or within software provided by IOtech.

Included with each DaqBoard is DaqCal™ software, an easy-to-operate, user-calibration package, allowing users to calibrate their DaqBoard. Two calibration modes are supported in DaqCal. Self-cal, a user cal mode for analog inputs, can be performed automatically in minutes with included software and without the use of external hardware or instruments. Self-cal derives its traceability through an on-board reference which has a stability of 0.005% per year. The second mode, user-cal, is for users that require traceability to international standards such as NIST. A 6-1/2 digital multimeter is required and user-calibration software is included with step-by-step instructions for full calibration. This process is automated when using a digital multimeter specified by IOtech*. A 2-year calibration period is recommended for the DaqBoard/3000 series.

Analog Output

(DaqBoard/3000 and /3001 Only)

Two or four 16-bit, 1-MHz analog output channels are built into the DaqBoard/3000 series with an output range from -10V to +10V. Through the use of Bus Mastering DMA, each D/A output can continuously output a waveform at up to 1 MHz, which can be read from PC RAM or a file on the hard disk. In addition, a program can asynchronously output a value to any of the D/As for non-waveform applications, presuming that the D/A is not already being used in the waveform output mode. Lastly,

each of the analog outputs can be used in a control mode, where their output level is dependent on whether an associated analog, digital or counter input is above or below a user-specified limit condition.

When used to generate waveforms, the D/As can be clocked in several different modes. Each D/A can be separately selected to be clocked from one of the sources described as follows.

Asynchronous Internal Clock. The on-board programmable clock can generate updates ranging from once every 19 hours to 1 MHz, independent of any acquisition rate.

Synchronous Internal Clock. The rate of analog output update can be synchronized to the acquisition rate derived from 1 MHz to once every 19 hours.

Asynchronous External Clock. A user-supplied external input clock can be used to pace the D/A, entirely independent of analog inputs.

Synchronous External Clock. A user-supplied external input clock can pace both the D/A and the analog input.

Digital I/O

Twenty four TTL-level digital I/O lines are included in the DaqBoard/3000 series. Digital I/O can be programmed in 8-bit groups as either inputs or outputs and can be scanned in several modes (see Input Scanning). Ports programmed as inputs can be part of the scan group and scanned along with analog input channels, or can be asynchronously accessed via the PC at any time, including when a scanned acquisition is occurring. Two synchronous modes are supported when scanned along with analog inputs. One mode is where the digital inputs are scanned at the start of each scan sequence, which means the rate at which they are scanned is dependent on the number of analog input channels, and the delay period. For example, if 8 analog inputs are enabled with 0 delay period, then the digital inputs in this mode would be scanned at once per 8 μ s, which is 125 kHz.

In the other synchronous mode, the enabled digital inputs are scanned synchronously with every analog input channel. So in the example above, the digital inputs would be scanned at once per μ s, or 1 MHz.

If no analog inputs are being scanned, the digital inputs can be scanned at up to 12 Msamples/s.

Digital Outputs and Pattern Generation

Digital outputs can be updated asynchronously at anytime before, during or after an acquisition. Two of the 8-bit ports can also be used to generate a 16-bit digital pattern at up to 12 MHz. The DaqBoard/3000 series supports digital pattern generation via Bus Mastering DMA. In the same manner as analog output, the digital pattern can be read from PC RAM or a file on the hard disk. Digital pattern generation is clocked in the same four modes as described with analog output.

The ultra low-latency digital output mode allows a digital output to be updated based on the level of an analog, digital, or counter input. In this mode, the user associates a digital output bit with a specific input, and specifies the level of the input where the digital output changes state. The response time in this mode is dependent on the number of input channels being scanned, and can typically be in the range of 2 to 20 μ s.

Counter Inputs

Four 32-bit counters are built into the DaqBoard/3000 series. Each of the four counters will accept frequency inputs up to 20 MHz, and each counter channel can be configured in a variety of modes including counter, period, pulse width, time between edges, or multi-axis quadrature encoder. The counters can concurrently monitor time periods, frequencies, pulses, and other event-driven incremental occurrences from encoders, pulse generators, limit switches, proximity switches, and magnetic pick-ups. As with all other inputs to the DaqBoard/3000 series, the counter inputs can be read asynchronously under

* Contact factory for user calibration availability

DaqBoard/3000™ Series

General Information & Specifications

program control, or synchronously as part of an analog and digital scan group based either on an internal programmable timer, or an external clock source. The use of Z-channel encoders or usage of mapped channels requires that these channels need to be read synchronously.

The DaqBoard/3000 supports quadrature encoders with up to 2 billion pulses per revolution, 20-MHz input frequencies, and x1, x2, x4 count modes. With only A phase and B phase signals, 2 channels are supported. With A phase, B phase, and Z index signals, 1 channel is supported. Each input can be debounced from 500 ns to 25.5 ms (total of 16 selections) to eliminate extraneous noise or switch induced transients. Encoder input signals must be within -15V to +15V and the switching threshold is TTL (1.3V). Power is available for encoders, +5V at up to 500 mA.

Timer Outputs

Two 16-bit timer outputs are built into the DaqBoard/3000, each capable of generating different square waves with a programmable frequency range from 16 Hz to 1 MHz.

Multiple DaqBoards per PC

All of the features described for the DaqBoard/3000 can be replicated with up to four DaqBoard/3000s installed in the same PC. The serial number on each DaqBoard/3000 is used to differentiate one from another, and a user-selected name can be assigned to each board for easy program documentation. When multiple boards are installed, all boards can be operated synchronously by designating one board as the master. All of the other boards are then slaves, and are synchronized to the master via the pacer clock which is externally routed to the designated slave boards.

Voltage Range*	Accuracy ±(% of reading + % Range) 23°C ±10°C, 1 year	Temperature Coefficient ±(ppm of reading + ppm Range)/°C 0°C to 13°C and 33°C to 60°C	Noise** (cts RMS)
-10V to 10V	0.031% + 0.008%	14 + 8	1.5
-5V to 5V	0.031% + 0.009%	14 + 9	2.0
-2V to 2V	0.031% + 0.010%	14 + 10	1.6
-1V to 1V	0.031% + 0.02%	14 + 12	2.5
-500 mV to 500 mV	0.031% + 0.04%	14 + 18	4.0
-200 mV to 200 mV	0.036% + 0.075%	14 + 12	5.0
-100 mV to 100 mV	0.042% + 0.15%	14 + 18	9.0

* Specifications assume differential input single channel scan, 1-MHz scan rate, unfiltered, CMV=0.0V, 30 minute warm-up, exclusive of noise

** Noise reflects 10,000 samples at 1-MHz, typical, differential short, CA-G56

Note: DaqBoard/3006 is single-ended only, 0.040% + 0.010% accuracy, 14 + 8 temperature coefficient, 2.0 noise

Specifications

General

Power Consumption (per board): 3W

Operating Temperature: 0° to +60°C

PCI Bus: PCI r2.2 compliant, universal 3.3V/5V signaling support, compatible with PCI-X

Storage Temperature: -40° to +80°C

Relative Humidity: 0 to 95% non-condensing

Vibration: MIL STD 810E cat 1 and 10

Signal I/O Connector: 68-pin standard "SCSI Type III" female connector

Dimensions: 165 mm W x 15 mm x 108 mm H (6.5" x 0.6" x 4.2")

Weight: 160 g (0.35 lbs)

Analog Inputs

Channels: 16 single-ended or 8 differential, programmable on a per channel basis as single-ended or differential†

Expansion: An additional 48 analog inputs per board via optional PDQ30 module, expansion channels have identical features as the main board channels†

Expansion Connector: HDMI connector†

Over-Voltage Protection: ±30V without damage

Ranges: Software or sequencer selectable on a per channel basis, ±10V, ±5V, ±2V, ±1V, ±0.5V, ±0.2V, ±0.1V†

Input Impedance: 10M Ohm single-ended; 20M Ohm differential

Total Harmonic Distortion: -80 dB typ for ±10V range, 1 kHz fundamental

Signal to Noise and Distortion: 72 dB typ for ±10V range, 1 kHz fundamental

Bias Current: 40 pA typical (0°C to 35°C)

Crosstalk: -75 dB typical DC to 60 Hz; -65 dB typical @10 kHz

Common Mode Rejection: -70 dB typical DC to 1 kHz

Maximum Usable Input Voltage + Common Mode Voltage	
Ranges	Maximum (CMV + Vin)
0.5, 1, 2, 5, 10V	10.5V
0.1, 0.2V	2.1V

A/D Specifications

Type: Successive approximation

Resolution: 16 bit

Maximum Sample Rate: 1 MHz

Nonlinearity (Integral): ±2 LSB maximum

Nonlinearity (Differential): ±1 LSB maximum

Input Sequencer

Analog, digital, and frequency inputs can be scanned synchronously, based on either an internal programmable timer, or an external clock source. Analog and digital outputs can be synchronized to either of these clocks.

Scan Clock Sources: 2

Note: The maximum scan clock rate is the inverse of the minimum scan period. The minimum scan period is equal to 1 μs times the number of analog channels. If a scan contains only digital channels then the minimum scan period is 83 ns times the number of digital channels.

1. Internal, programmable

Analog Channels from 1 μs to 19 hours in 20.83 ns steps

Digital Channels and Counters from 83.33 ns to 19 hours in 20.83 ns steps

2. External, TTL level input

Analog Channels down to 1 μs min

Digital Channels and counters down to 83 ns min

Programmable Parameters per Scan: Channel (random order), gain

Depth: 512 locations

On-Board Channel-to-Channel Scan Rate:

Analog: 1 MHz maximum

Digital: 12 MHz if no analog channels are enabled, 1 MHz with analog channels enabled

External Acquisition Scan Clock Input

Maximum Rate: 990 kHz

Clock Signal Range: Logical zero 0V to 0.8V; logical one 2.4V to 5.0V

Minimum Pulse Width: 50 ns high, 50 ns low

Triggering

Trigger Sources: 6, individually selectable for starting and stopping an acquisition. Stop acquisition can occur on a different channel than start acquisition; stop acquisition can be triggered via modes 2, 4, 5, or 6 described below.

1. Single-Channel Analog Hardware Trigger

Any analog input channel can be software programmed as the analog trigger channel, including any of the analog expansion channels

Input Signal Range: -10 to +10V max

Trigger Level: Programmable (12-bit resolution)

Hysteresis: Programmable (12-bit resolution)

Latency: 350 ns typ, 1.3 μs max

Accuracy: ±0.5% of reading, ±2 mV offset

Noise: 2 mV RMS

† Except /3006, which is limited to 16 single-ended analog inputs with a fixed range of 10V. OEMs contact the factory for other range configurations.

DaqBoard/3000™ Series

Specifications

2. Single-Channel Analog Software Trigger

Any analog input channel, including any of the analog expansion channels, can be selected as the software trigger channel. If the trigger channel involves a calculation, such as temperature, then the driver automatically compensates for the delay required to obtain the reading, resulting in a maximum latency of one scan period.

Input Signal Range: Anywhere within range of the selected trigger channel

Trigger Level: Programmable (16-bit resolution), including "window triggering"

Latency: One scan period max

3. Single-Channel Digital Trigger

A separate digital input is provided for digital triggering.

Input Signal Range: -15V to +15V

Trigger Level: TTL

Minimum Pulse Width: 50 ns high, 50 ns low

Latency: 100 ns typ, 1.1 µs max

4. Digital Pattern Triggering

8- or 16-bit pattern triggering on any of the digital input ports. Programmable for trigger on equal, above, below, or within/outside of a window. Individual bits can be masked for "don't care" condition.

Latency: One scan period max

5. Counter/Totalizer Triggering

Counter/totalizer inputs can trigger an acquisition. User can select to trigger on a frequency or on total counts that are equal, above, below, or within/outside of a window.

Latency: One scan period, max

6. Software Triggering

Trigger can be initiated under program control.

Analog Outputs

(/3000 and /3001 models only)

Analog output channels are updated synchronously relative to scanned inputs, and clocked from either an internal on-board clock, or an external clock source. Analog outputs can also be updated asynchronously, independent of any other scanning in the system. Bus mastering DMA provides CPU and system-independent data transfers, ensuring accurate outputs that are irrespective of other system activities. Streaming from disk or memory is supported, allowing continuous waveform outputs (limited only by available PC system resources).

Channels: 2 (/3000); 4 (/3001)

Resolution: 16 bits

Data Buffer: PC-based memory

Output Voltage Range: ±10V

Output Current: ±10 mA

Offset Error: ±0.0045V max

Digital Feedthrough: <10 mV when updated

DAC Analog Glitch: <12 mV typical at major carry

Gain Error: ±0.01%

Update Rate: 1 MHz max, 19 hours min (no minimum with external clock), resolution 20.83 ns

Settling Time: 2 µs to rated accuracy

Clock Sources: 4, programmable

1. On-board D/A clock, independent of scanning input clock
2. Onboard scanning input clock
3. External D/A input clock, independent of external scanning input clock
4. External scanning input clock

Digital I/O

Channels: 24

Ports: 3 x 8-bit, each port is programmable as input or output

Input Scanning Modes: 2 programmable

1. Asynchronous, under program control at any time relative to input scanning

2. Synchronous with input scanning

Input Characteristics: 10K Ohm pull up to +5V, 20pF to common

Input Protection: ±15 kV ESD clamp diodes

Input Levels:

Low: 0 to 0.8V

High: +2.0V to +5.0V

Output Levels:

Low: <0.8V

High: >2.0V

Output Characteristics: Output 12 mA per pin, 200 mA total continuous

Sampling/Update Rate: 12 MHz max

Pattern Generation Output

Two of the 8-bit ports can be configured for 16-bit pattern generation. The pattern can also be updated synchronously with an acquisition at up to 12 MHz.

Counter

Each of the four high speed, 32-bit counter channels can be configured for counter, period, pulse width, time between edges, or multi-axis quadrature encoder modes. Counter inputs can be scanned synchronously along with analog and digital scanned inputs, based on an internal programmable timer, or an external clock source.

Channels: 4 x 32-bit

Input Frequency: 20 MHz max

Input Signal Range: -5V to +10V

Input Characteristics: 10K Ohm pull-up, ±15 kV ESD protection

Trigger Level: TTL

Minimum Pulse Width: 25 ns high, 25 ns low

Debounce Times: 16 selections from 500 ns to 25.5 ms; positive or negative edge sensitive; glitch detect mode or debounce mode

Time Base Accuracy: 30 ppm (0° to 50°C)

Five Programmable Modes: Counter, Period, Pulse-width, Timing, Encoder

Counter Mode Options: Totalize, Clear on Read, Rollover, Stop at all Fs, 16- or 32-bit, any other channel can gate or decrement the counter

Period Mode Options: Measure x1, 10, 100, or 1000 periods, 16- or 32-bit, 4 different time bases to choose from: 20.83 ns, 208.3 ns, 2.083 µs, 20.83 µs, any other channel can gate the period measurement

Pulsewidth Mode Options: 16- or 32-bit values, 4 different time bases to choose from: 20.83 ns, 208.3 ns, 2.083 µs, 20.83 µs, any other channel can gate the pulsewidth measurement

Timing Mode Options: 16- or 32-bit values, 4 different time bases to choose from: 20.83 ns, 208.3 ns, 2.083 µs, 20.83 µs

Encoder Mode Options: x1, 2, 4 options, 16- or 32-bit values, Z-channel clearing of counter, any other channel can gate the counter

Power Available for Encoders: 5V @ 500 mA max

Multi-axis Quadrature Encoder Inputs:

- 1 channel with A (phase), B (phase) and Z (index)
- 2 channel with A (phase) and B (phase)
- x1, x2, and x4 count modes
- Single-ended TTL

Frequency/Pulse Generators

Channels: 2 x 16-bit

Output Waveform: Square wave

Output Rate: 1 MHz base rate divided by 1 to 65535 (programmable)

High-Level Output Voltage: 2.0V min @ -1.0 mA; 2.9V min @ -400 µA

Low-Level Output Voltage: 0.4V max @ 400 µA

PDQ30

See the PDQ30 data sheet for complete specifications



PDQ30, expansion module

DaqBoard/3000™ Series

Ordering Information

Ordering Information

Description	Part No.
16-bit, 1-MHz PCI data acquisition board with 16 analog inputs with a single-ended 10V range (not expandable with PDQ30), 24 digital I/O, four counters, and two timers; includes DaqView™; support for Visual Studio® and Visual Studio® .NET, including examples for Visual C++®, Visual C#®, Visual Basic®, and Visual Basic® .NET; drivers for DASyLab®, LabVIEW®, and MATLAB®; and DaqCal™ software application for easy user-calibration	DaqBoard/3006
16-bit, 1-MHz PCI data acquisition board with 8DE/16SE analog inputs, 7 input ranges from 100 mV to 10V full-scale, 24 digital I/O, four counters, and two timers; includes DaqView; support for Visual Studio and Visual Studio .NET, including examples for Visual C++, Visual C#, Visual Basic, and Visual Basic .NET; drivers for DASyLab, LabVIEW, and MATLAB; and DaqCal software application for easy user-calibration	DaqBoard/3005
Same as DaqBoard/3005 but with two 16-bit, 1-MHz analog outputs	DaqBoard/3000
Same as DaqBoard/3005 but with four 16-bit, 1-MHz analog outputs	DaqBoard/3001
Analog input expansion module, adds 48SE/24DE channels to DaqBoard/3000 series; connects via a CA-266-x cable	PDQ30

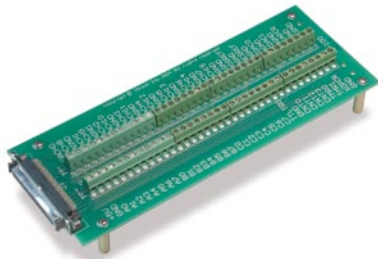

The TB-100 termination board with screw terminals, provides access to all DaqBoard/3000 series I/O. The TB-100 can be panel mounted or 19" rack mounted using optional Rack3.

Accessories & Cables

Description	Part No.
Termination board with screw-terminals for access to DaqBoard/3000 series I/O; connects via a CA-G55, CA-G56, or CA-G56-6 cable	TB-100 Rack3
Rack-mount kit for TB-100	
BNC termination module with 16 BNC connectors and internal screw terminal connections; connects via a CA-G55, CA-G56, or CA-G56-6 cable	DBK215
68-conductor ribbon expansion cable from DaqBoard/3000 series boards to TB-100, or DBK215 3 ft.	CA-G55
68-conductor shielded cable from DaqBoard/3000 series boards to TB-100, or DBK215, 3 ft.	CA-G56
68-conductor shielded cable from DaqBoard/3000 series boards to TB-100, or DBK215, 6 ft.	CA-G56-6
HDMI cable, connects PDQ30 to DaqBoard/3000 series, 3 ft.	CA-266-3
HDMI cable, connects PDQ30 to DaqBoard/3000 series, 6 ft.	CA-266-6



CA-G55, 68-conductor low-cost cable



CA-G56, 68-conductor shielded cable

Software

DaqView add-on for seamless execution with Microsoft Excel's tool palette	DaqViewXL/Plus
DaqView add-on includes all of the features of DaqViewXL/Plus, plus frequency-domain analysis	DaqView/Pro
Icon-based data acquisition, graphics, control, and analysis software	DASyLab

BUY NOW!

For complete product specifications, pricing, and accessory information, call 1-888-714-3272 (U.S. only) or visit iotech.com.



The DBK215 provides 16 BNC connectors plus internal screw-terminal connections



CA-266-3, DaqBoard/3000 Series to PDQ30 cable

* Requires CA-266-x cable to connect DaqBoard/3000 series to PDQ30