

DaqBoard/2000™ Series

16-Bit, 200-kHz PCI Data Acquisition Boards

iOtech
iotech.com

Features

- Three DaqBoard/2000 series PCI boards are available
- 16-bit, 200-kHz A/D converter
- 8 differential or 16 single-ended analog inputs (software selectable per channel)
- Expandable up to 256 analog input channels, while maintaining 200 kHz (5 μ s per channel) scan rate
- Up to four boards can be installed into one PC for up to 1024 analog input channels
- 100% digital calibration
- 512 location channel/gain FIFO, capable of scanning all channels, including 256 analog expansion channels and digital/counter channels, at 5 μ s per channel
- DMA bus mastering for synchronous analog I/O, digital I/O, and counter inputs
- Trigger modes include analog, digital, and software, with <5 μ s latency
- Virtually infinite pre-trigger buffer*
- Up to four 16-bit, 100-kHz analog outputs with infinite continuous waveform output capability*
- 40 digital I/O lines, can be scanned synchronously or asynchronously with analog inputs
- Digital I/O is expandable up to 272 lines, including optional isolation and relay closure
- Four counter/pulse input channels can be scanned synchronously or asynchronously with analog inputs
- Two timer/pulse output channels

Signal Conditioning Options

- Signal conditioning and expansion options for thermocouples, strain gages, accelerometers, isolation, RTDs, etc.—over 40 options in all

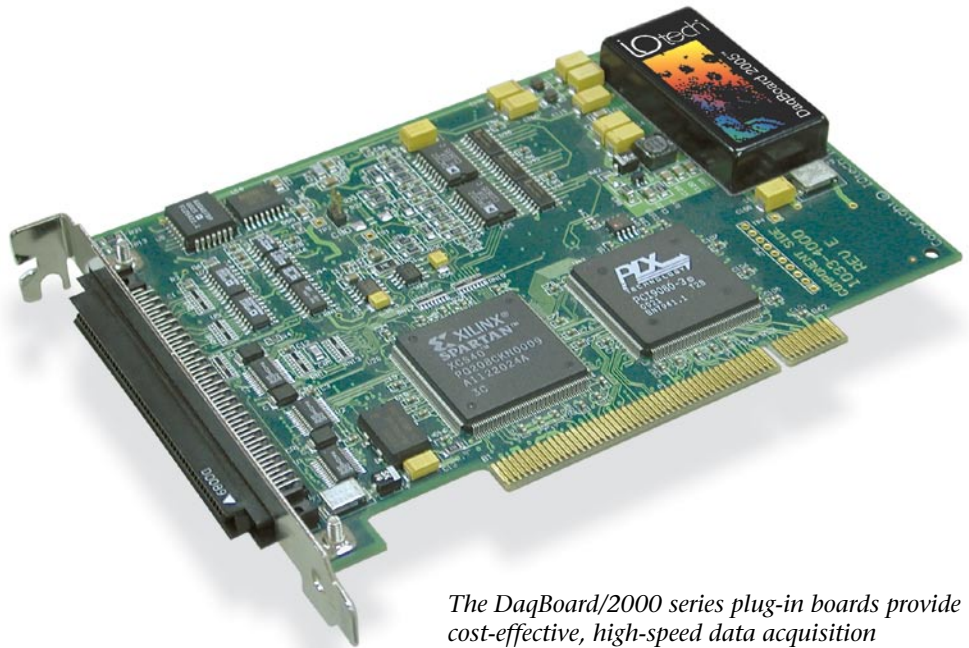

The DaqBoard/2000 series plug-in boards provide cost-effective, high-speed data acquisition

Software

- Includes DaqView™ *Out-of-the-Box*™ software application for effortless data logging and analysis
- Support for Visual Studio® and Visual Studio® .NET, including examples for Visual C++®, Visual C#®, Visual Basic®, and Visual Basic® .NET; Linux support also available
- Comprehensive drivers for DASyLab®, LabVIEW®, and MATLAB®
- DaqCal™ software application for easy user calibration

The DaqBoard/2000™ series sets the price/performance benchmark for high-speed, multifunction plug-and-play data acquisition for PCI bus computers. The DaqBoard/2000 series hardware design offers all of the features normally found on significantly more expensive boards, including 16-bit, 200-kHz A/D, 100% digital calibration, bus mastering, two or four 16-bit, 100-kHz D/A converters, 40 digital I/O lines, four counters, and two timers.

DaqBoard/2000 series is supported by a growing family of over 40 signal conditioning and expansion options, offering signal conditioning for thermocouples, RTDs, accelerometers, isolation, high-voltage, strain gages, and much more. Up to 528 channels of analog and digital I/O can be accessed using one DaqBoard/2000, while maintaining the 5 μ s per channel update rate. Up to four DaqBoard/2000s can be installed into one PC.

Software support for the DaqBoard/2000 series includes support for Visual Studio® and Visual Studio® .NET, including examples for Visual C++®, Visual C#®, Visual Basic®, and Visual Basic® .NET, plus comprehensive drivers for DASyLab®, LabVIEW®, and MATLAB®. Also included is DaqView *Out-of-the-Box*™ software for quick and easy set up and collection of data without programming, along with DaqCal™ software application for easy user calibration. Linux support is also available.

In total, the DaqBoard/2000 series sets the industry standard for plug-and-play PCI data acquisition.

* Limited only by available PC RAM and hard disk space

DaqBoard/2000™ Series

General Information

DaqBoard/2000™ Series Selection Chart

Feature	Multifunction I/O		
	/2001	/2000	/2005
Analog inputs (16 bit/200 kHz)	16	16	16
Analog outputs (16 bit/100 kHz)	4	2	—
Digital I/O	40	40	40
Freq./pulse I/O	6	6	6

Synchronous I/O for High-Speed Applications

The DaqBoard/2000 series sets a new standard with its ability to make analog measurements, read digital inputs, and read counter inputs, while synchronously generating up to four analog outputs and/or a 16-bit digital pattern output. Most other boards require CPU interaction to access I/O other than analog input, making it impossible to generate time-critical analog waveforms or digital patterns. With the DaqBoard/2000 series, the true power of today's PCI-based PCs can be unleashed.

The same synchronous features of the DaqBoard extend to its family of DBK™ signal conditioning and expansion options. Up to 256 analog input channels and 272 (256, P2 only) digital I/O channels can also be accessed synchronously to one another, with precise and deterministic channel-to-channel timing. Up to four DaqBoards can be installed in one PC, quadrupling the channel capacity to over 1,000 analog input channels, 1,000 digital I/O channels and 16 high-speed analog output channels.

Signal I/O

One 100-pin connector on the DaqBoard/2000 series provides access to all of the input and output signals. Unlike other multifunction boards that require multiple PC slots in order to access all of the I/O, careful design of the DaqBoard/2000 series accommodates all I/O using one cable, and utilizing a single PCI slot.

The 100-pin DaqBoard/2000 series I/O connector, P4, is logically divided into three sub-ports, P1, P2, and P3. P1, the analog

input port, contains all of the analog input channels, as well as the sequencer control signals for accessing external analog input options. All analog expansion options attach to the P1 port. P2, the general purpose digital I/O port, can be used directly to control and monitor 24 digital I/O lines. P2 can also function as the digital I/O expansion port, whereby the 24 lines are exclusively used to control external digital DBK expansion options, for up to 256 lines of digital input or output. P3 contains an additional 16-bit digital I/O port, as well as the counter inputs, timer outputs, and analog outputs. Several options are available to provide easy user access to all of the I/O signals on P4.

Analog Input (P1)

The DaqBoard/2000 series has a 16-bit, 200-kHz A/D coupled with 16 single-ended, or 8 differential analog inputs. Thirteen software programmable ranges provide inputs from ±10V to ±156 mV full scale. Each channel can be software-configured for a different range, as well as for single-ended or differential, and unipolar or bipolar input. Beyond the 16 built-in analog inputs, the user can expand the DaqBoard/2000 series up to 256 analog inputs using external DBK signal conditioning and expansion options. As with the on-board channels, expansion channels are scanned at the same 5 µs/channel rate (200 kHz), and most are software-programmable for range. There is *no* speed penalty for scanning expansion channels versus built-in channels. The DBK expansion options offer a wide variety of signal measurements, including thermocouples, RTDs, strain gages, accelerometers, high voltage, isolation, current, and much more.

Scanning

The DaqBoard/2000 series has an on-board scan sequencer that permits the user to select any combination of up to 512 channel/range combinations. The sequencer scans all channels contained in the sequence at the fastest rate of 5 µs/channel, thereby minimizing the time-skew from channel-to-channel. The user can also set the time between scan groups, from 0 to 6 hours. In addition to scanning analog inputs, the sequencer can scan digital inputs and counter inputs.

Bus Mastering DMA

The DaqBoard/2000 series supports Bus Mastering DMA, which allows analog and digital/counter input data, as well as analog and digital output data to flow between the PC and the DaqBoard/2000 series without consuming valuable CPU time. The driver supplied with the DaqBoard/2000, as well as all other third-party software support such as DASyLab®, LabVIEW®, and MATLAB®, automatically utilize Bus Mastering DMA to efficiently conduct I/O from the PC to the DaqBoard.

Triggering

Triggering can be the most critical aspect of a data acquisition application. The DaqBoard/2000 series supports a full complement of trigger modes to accommodate any measurement situation.

Hardware Analog Triggering. Many data acquisition boards claim analog triggering, but rely on the PC to take readings and make a decision, which leads to uncertain and potentially long latencies. The DaqBoard/2000 series uses true analog triggering, whereby the trigger level programmed by the user sets an analog

DaqBoard/2000™ Series

General Information

DaqBoard/2000, /2001, and /2005 Block Diagram

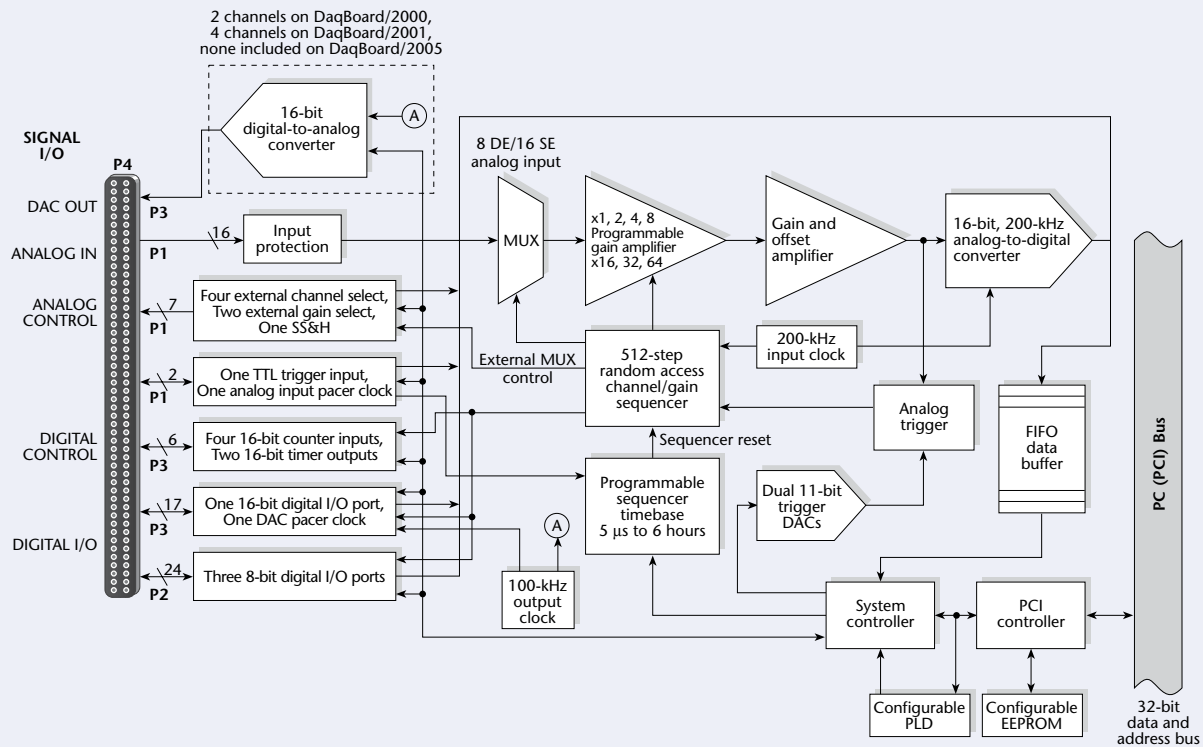

DAC, which is then compared in hardware to the analog input level on the selected channel. The result is analog trigger latency which is guaranteed to be less than 5 μs, significantly shorter than most data acquisition boards. Any analog channel can be selected as the trigger channel, including built-in or expansion channels. The user can program both the trigger level, as well as the edge (rising or falling).

Digital and Pattern Triggering (P1). A separate digital trigger input line is provided, allowing TTL-level triggering, again with latencies guaranteed to be less than 5 μs. Both the logic levels (1 or 0), as well as the edge (rising or falling), can be programmed for the discrete digital trigger input.

Software-Based Triggering. Software-based triggering differs from the modes described above because the readings, analog, digital, or counter, are interrogated by the PC to detect the trigger event, not in

the hardware as described above. The advantage of this mode is to permit triggering based on more complex situations, such as on a specific temperature, which was derived from the acquisition of at least two analog measurements, plus the calculation of the measured temperature using linearization algorithms.

The DaqBoard/2000 series also supports digital pattern triggering, whereby the user can designate any of the digital input ports as the trigger port. The programmed digital pattern, including the ability to mask or ignore specific bits, is then compared to the actual input until a match is detected, after which the sequencer begins the scan sequence.

Triggering can also be programmed to occur when one of the counters reaches, exceeds, or is within a programmed level. Any of the built-in counter/totalizer channels can be programmed as a trigger source.

Normally software-based triggering results in long latencies from the time that a trigger condition is detected, until the actual capturing of data commences. However, the DaqBoard/2000 series circumvents this undesirable phenomenon by use of pre-trigger data. Specifically, when software-based triggering is employed, and the PC detects that a trigger condition has occurred, (which may be thousands of readings later than the actual occurrence of the signal), the DaqBoard driver automatically looks back to the location in memory where the actual trigger-causing measurement occurred. The acquired data that is presented to the user actually begins at the point where the trigger-causing measurement occurs. The latency in this mode is equal to one scan cycle.

Stop Trigger. Any of the software trigger modes described above can also be used to stop an acquisition. Thus an acquisition can be programmed to begin on one

DaqBoard/2000™ Series

General Information

event, such as a temperature level, and then can stop on another event, such as a digital pattern.

Pre- and Post-Triggering Modes. Six modes of pre- and post-triggering are supported, providing a wide variety of options to accommodate any measurement requirement. When using pre-trigger, the user must use software-based triggering to initiate an acquisition.

No pre-trigger, post-trigger stop event. This, the simplest of modes, acquires data upon receipt of the trigger, and stops acquiring upon receipt of the stop-trigger event.

Fixed pre-trigger with post-trigger stop event. In this mode, the user specifies the number of pre-trigger readings to be acquired, after which, acquisition continues until a stop-trigger event occurs.

No pre-trigger, infinite post-trigger. No pre-trigger data is acquired in this mode. Instead, data is acquired beginning with the trigger event, and is terminated when the operator issues a command to halt the acquisition.

Fixed pre-trigger with infinite post-trigger. The user specifies the amount of pre-trigger data to acquire, after which the system continues to acquire data until the program issues a command to halt acquisition.

Variable pre-trigger with post-trigger stop event*. Unlike the previous pre-trigger modes, this mode does not have to satisfy the pre-trigger number of readings before recognizing the trigger event. Thus the number of pre-trigger readings acquired is variable and dependent on the time of the trigger event relative to the start. In this mode, data continues to be acquired until the stop trigger event is detected.

Variable pre-trigger with infinite post-trigger*. This is similar to the mode described above, except that the acquisition is terminated upon receipt of a command from the program to halt the acquisition.

* Driver support only

Channel-Scanning Flexibility

The DaqBoard/2000 series offers a 512-location scan sequencer that allows you to select each channel and associated input amplifier gain at random. The sequencer circuitry circumvents a major limitation encountered with many plug-in data acquisition boards—a drastic reduction in the scan rate for external expansion channels. All DaqBoard/2000 series channels, including the 528 potential expansion channels, are scanned at 100K or 200 kHz (1 or 5 μ s/channel), software programmable per channel. In addition, the digital and frequency inputs can be scanned using the same scan sequence employed for analog inputs, enabling the time correlation of acquired digital data to acquired analog data. The DaqBoard/2000 series permits each scan group, which can contain up to 512 channel/gain combinations, to be repeated immediately or at programmable intervals of up to 6 hours. Within each scan group, consecutive channels are measured at a fixed 5 μ s/channel rate.

DaqBoard/2000 Series Scanning Example

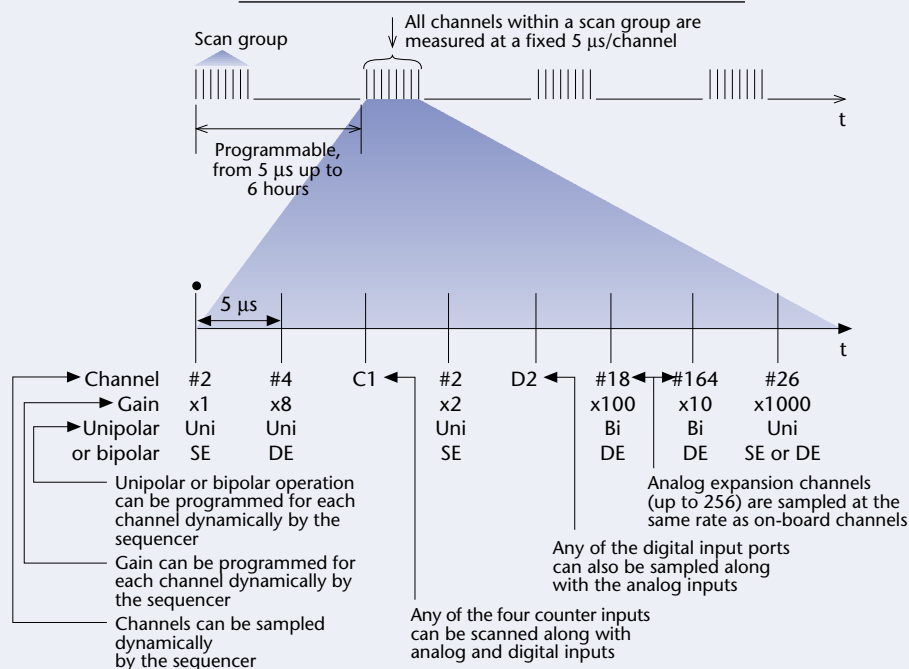

Calibration

Every range on the DaqBoard/2000 series is calibrated from the factory using a digital calibration method. This method works by storing a correction factor for each range on the DaqBoard/2000 series at the time of calibration. Whenever a particular range is selected, the appropriate calibration constant is automatically applied to a compensating DAC, thereby calibrating the specific range. The result is that readings generated by the A/D are already calibrated, and do not require additional processing.

This is significantly better than other boards, that merely adjust the readings in software after they are transferred to the PC. That method has the disadvantage of reducing the dynamic range of the A/D, and can adversely affect the speed at which the PC can obtain a calibrated reading.

The DaqBoard/2000 series also has a user-cal mode, whereby the user can adjust the calibration of the board in their system, without destroying the factory

DaqBoard/2000™ Series

General Information

calibration supplied with the board. This is accomplished by having 2 distinct calibration tables in the DaqBoard/2000 series on-board EPROM, one which contains the factory cal, and the other which is available for user calibration.

Analog Output (P3)

DaqBoard/2000, & /2001 Only

Two or four 16-bit, 100-kHz analog output channels are built into the DaqBoard/2000 series, with an output from -10V to +10V. These outputs are entirely separate from the D/As which are used to determine analog trigger level (some data acquisition board suppliers confusingly refer to trigger D/As as if they are available to the user). Through the use of Bus Mastering DMA, each D/A output can continuously output a waveform, which can be read from PC RAM or a file on the hard disk. In addition, a program can asynchronously output a value to either of the D/As for non-waveform applications, presuming that the D/A is not already being used in the waveform output mode. Additional low-speed D/A channels can be added to the DaqBoard through the use of the DBK2 analog output option card.

When used to generate waveforms, the D/As can be clocked in several different modes. Each D/A can be separately selected to be clocked from one of the sources described below.

Asynchronous Internal Clock. The on-board programmable clock can generate updates ranging from 1.5 Hz to 100 kHz, independent of any acquisition rate.

Synchronous Internal Clock. The rate of analog output update can be synchronized to the acquisition rate derived from 100 kHz to once every 5.96 hours.

Asynchronous External Clock. A user-supplied external input clock can be used to pace the D/A, entirely independent of analog inputs.

Synchronous External Clock. A user-supplied external input clock can pace both the D/A and the analog input.

DaqBoard/2000 Series Signal Conditioning & Expansion Options		
Product	Description	Capacity
DBK1	16-connector BNC interface module	16 connectors
DBK2	D/A voltage-output card	4 channels
DBK4	Dynamic signal-input card	2 channels
DBK5	Current output card	4 channels
DBK7	Frequency-to-voltage input card	4 channels
DBK8	High-voltage input card	8 channels
DBK9	RTD measurement card	8 channels
DBK10	Expansion-card enclosure module	3 cards
DBK11A	Screw-terminal card	40 terminals
DBK15	Universal current/voltage input card	16 channels
DBK16	Strain gage measurement card	2 channels
DBK17	Simultaneous sample and hold card	4 channels
DBK18	Low-pass filter card	4 channels
DBK20	Digital I/O card (screw-terminal connectors)	48 channels
DBK21	Digital I/O card (male DB37 connectors)	48 channels
DBK23	Optically isolated digital-input module	24 channels
DBK24	Optically isolated digital-output module	24 channels
DBK25	Relay output card	8 channels
DBK30A	Rechargeable battery/excitation module	14.4 or 28.8 VDC
DBK32A	Auxiliary power supply card	±15 VDC @ 500 mA
DBK41	Analog expansion enclosure module	10 cards
DBK42	5B isolated signal-conditioning module	16 channels
DBK43A	Strain gage module	8 channels
DBK44	5B isolated signal conditioning card	2 channels
DBK45	SS&H card with low-pass filter	4 channels
DBK48	8B isolated signal-conditioning module	16 channels
DBK50	Isolated high-voltage input module	8 channels
DBK51	Isolated low-voltage input module	8 channels
DBK55	Frequency-to-voltage input module	8 channels
DBK60	3-slot expansion module w/customizable panels	3 cards
DBK65	Transducer interface module	8 channels
DBK70	Vehicle network interface module	16 channels
DBK80	Differential voltage input card with excitation output	16 channels
DBK81	TC/mV card with screw-terminal connections	7 channels
DBK82	TC/mV card with screw-terminal connections	14 channels
DBK83	TC/mV card with external screw-terminal Pod and 3 ft. cable	14 channels
DBK84	TC/mV module with mini TC connector jacks	14 channels
DBK85	Differential voltage input module	16 channels
DBK200	Adapter board for analog inputs	P1
DBK202	Screw-terminal adapter board, solder locations for user-supplied resistors and R/C networks, with three expansion ports	120 terminals, P1, P2, P3
DBK203A	Same as DBK202 adapter board with a rugged metal enclosure	120 terminals, P1, P2, P3
DBK206	Adapter board with removable screw-terminals with three expansion ports	120 terminals, P1, P2, P3
DBK207	5B-isolated analog input signal conditioning board with two expansion ports	P1 (2)
DBK207/CJC	Same as DBK207 plus on-board, cold-junction compensation; two expansion ports	P1 (2)
DBK208	Opto-22® signal conditioning board for isolated (solid-state-relay) digital I/O, with two P2 digital I/O expansion ports	P2 (2)
DBK209	Same as DBK201 but rack and DIN-rail mountable with optional kits	P1, P2, P3
DBK210	Isolated high-density digital I/O board	32 channels
DBK213	Screw-terminal and expansion card module; 120 terminals, P1, P2, P3	48 channels
DBK214	16-connector BNC interface module; 120 terminals, P1, P2, P3	16 channels

DaqBoard/2000™ Series

General Information & Expansion Options

Digital Pattern Generation (P3)

The DaqBoard/2000 series supports digital pattern generation via Bus Mastering DMA on the 16-bit high-speed digital I/O port. In the same manner as Analog Output, the digital pattern can be read from PC RAM or a file on the hard disk. Digital pattern generation is clocked in the same four modes as described above with analog output*.

Digital Inputs and Outputs (P2, P3)

Forty TTL-level digital I/O lines are included in the DaqBoard/2000 series. They are divided into three 8-bit ports (P2) and one 16-bit port (P3). The P2 ports can be programmed in 8-bit groups as either input or output. The 16-bit P3 port can be programmed as all inputs or all outputs. Ports programmed as inputs can be part of the scan group and scanned along with other analog and digital input channels, or can be asynchronously accessed via the PC at any time, including when a scanned acquisition is occurring.

In addition, the P2 ports can be expanded up to 256 digital I/O lines using external DBK digital options. These options are available as TTL-level I/O, relay output, or optically isolated input and output. Whenever expansion digital I/O is attached to the DaqBoard/2000 series, the P2 I/O lines are no longer user-programmable, and are instead used to communicate with the digital expansion options.

DBK213™ Expansion Module

The DBK213™ module provides screw-terminal access plus expansion slots for the DaqBoard/2000™ series. The top of the DBK213 is easily removed to reveal screw-terminal connections that provide access to all analog and digital I/O from the host data acquisition board. Also included with the DBK213 are three expansion slots that can accommodate any DBK analog or digital expansion and signal conditioning cards.



Counter Inputs (P3)

Four 16-bit counters are built into the DaqBoard/2000, each capable of counting up to 65,536 TTL-level transitions. Each of the four counters will accept frequency inputs up to 10 MHz, and can be configured for pulse count or totalize mode. The counters can also be cascaded, allowing over four billion counts to be accumulated. As with all other inputs to the DaqBoard/2000 series, the counter inputs can be read asynchronously under program control, or synchronously as part of an analog and digital scan group.

Timer Outputs (P3)

Two 16-bit timer outputs are built into the DaqBoard/2000, each capable of generating different square waves with a programmable frequency range from 16 Hz to 1 MHz.

Multiple DaqBoards per PC

All of the features described for the DaqBoard/2000 can be replicated with up to four DaqBoard/2000s installed in the same PC. The serial number on each DaqBoard/2000 is used to differentiate one from another, and a user-selected name can be assigned to each board for easy program documentation. Thus, with four boards installed along with DBK expansion options, over 1,000 analog input channels and over 1,000 digital I/O channels could be accessed from one PC. When multiple boards are installed, all boards can be operated synchronously.

DBK214™ Expansion Module

The DBK214™ module provides 16 BNC connectors for accessing analog I/O, digital I/O, or counter/timer signals. In addition, screw-terminal connections for all signals are accessed by removing the DBK214's top cover. Eight of the BNC connectors are pre-defined as analog inputs and are jumper selectable as single ended or differential. Another eight BNC connectors can be configured by the user on a per channel basis as an analog input or output, digital I/O, or counter/timer channels.



* When digital pattern generation is used, one of the analog output channels is limited to asynchronous output mode

DaqBoard/2000™ Series

Expansion Options



The DaqBoard/2000 series provides all I/O signals on one 100-pin connector. The following adapter options make it easy for the user to attach signals and expansion options.

DBK200™ Adapter Board

To DBK option (P1)

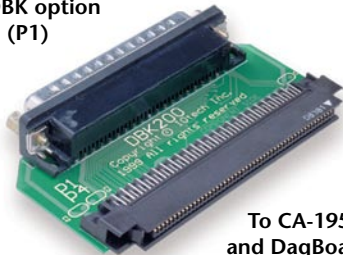

To CA-195 cable and DaqBoard/2000 series boards

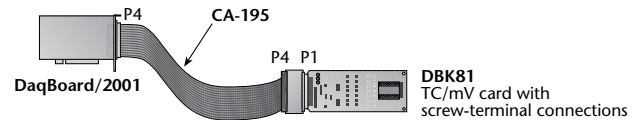

The DBK200 adapter mates directly with analog DBK signal conditioning options

Suitable exclusively for analog-signal expansion, the DBK200 adapter board contains one 100-pin connector which connects to the DaqBoard/2000 series via the CA-195 cable, and one female DB37 connector that mates directly with the P1 port of any of the DBK analog signal conditioning and expansion options. This is the most convenient way to add analog expansion options if access to the DaqBoard/2000 series digital I/O or frequency signals is not required. Access to P1 analog signals is also possible via included female-mating solder-lug connectors or optional CA-37-x* or CA-37-xT* expansion cables.

DBK209™ Adapter Board

For both analog and digital expansion, the DBK209 adapter board mates with the DaqBoard/2000 series via a 3-ft. CA-195 cable. The DBK209 provides three male DB37 connectors, divided into P1 analog input, P2 digital I/O, and P3 analog output and counter/timer I/O. Each port on the DBK209 connects to DBK expansion options via an optional CA-37-x* or CA-37-xT*

expansion cable. Alternatively, users can custom make their own cables that are terminated with a female DB37. An optional 6 ft. cable is available that contains a mating female DB37 connector at one end, and is unterminated at the other end (CA-113). The DBK209 is also snap-track (DIN-rail), and rack-mountable with optional mounting kits.

DBK209

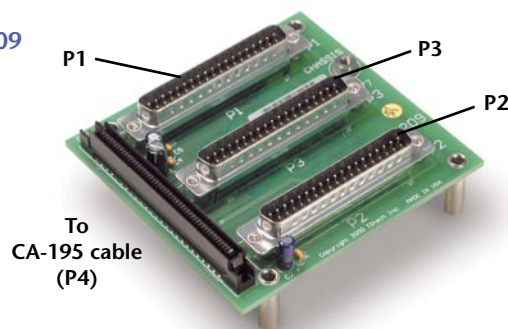

To CA-195 cable (P4)

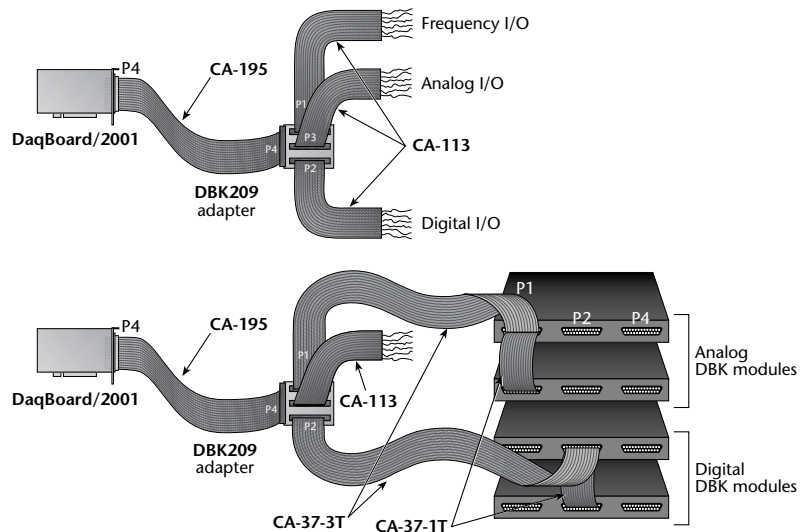

The DBK209 adapter with analog and digital DBK signal conditioning and expansion modules

The CA-195 100-pin conductor cable connects the DaqBoard/2000 series boards with the DBK200 series adapters

* The "x" in the cable part numbers should be replaced by the number of expansion products to be connected

DaqBoard/2000™ Series

Expansion Options

DBK202™ Screw-Terminal Adapter Board

The DBK202 screw-terminal board provides convenient screw-terminal access to all signals from the DaqBoard/2000 series. Divided into three ports (P1, P2, and P3), the DBK202 also provides another way to access signals. There are male DB37 connectors on P1 and P2 which can be used to connect to DBK signal conditioning and expansion options. Mounting holes in the DBK202 permit it to be easily screw-mounted into a user-provided enclosure.



DBK203A

DBK203A™ Screw-Terminal Adapter Module

The DBK203A is identical to the DBK202, except that it is housed in a shielded metal enclosure, which easily mounts to other DBK signal conditioning and expansion modules.

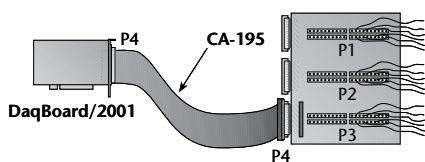

The DBK202 adapter with screw-terminal connectors

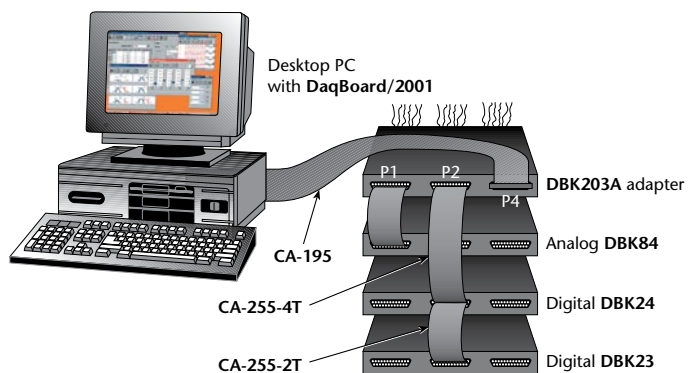

The DBK203A adapter with screw-terminal connectors

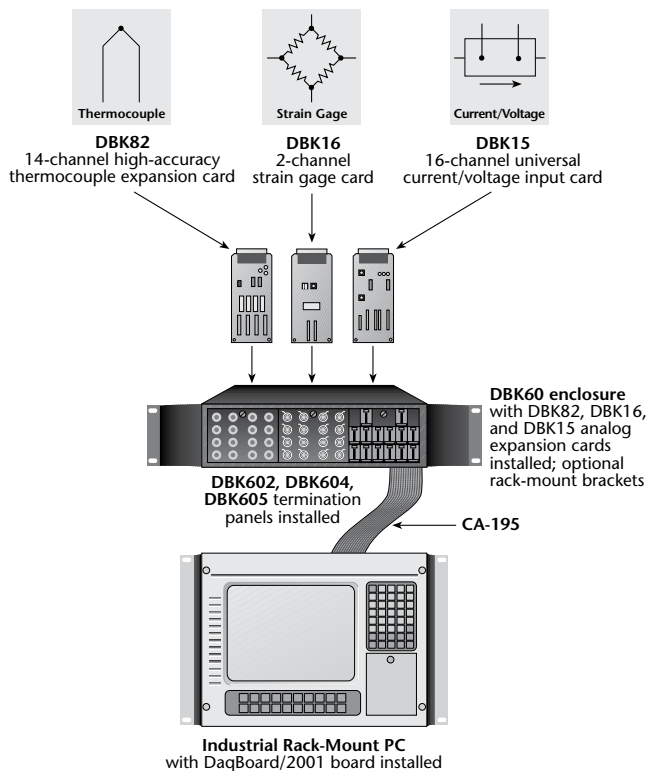

The DBK60 ruggedized rack-mount enclosure with optional signal conditioning and termination panels

DaqBoard/2000™ Series

Expansion Options



DaqBoard/2000 Series Expansion Options for Rack-Mount Systems

The DaqBoard/2000 series can be expanded up to 100s of analog and digital channels in a rack-mount system, with only *one* cable back to the DaqBoard. This is possible because of the unique capability built into the DaqBoard/2000 series and the DBK200™ series options. Specifically, the DBK206™, DBK207™, DBK208™, and DBK210™ have on-board multiplexing and daisy-chain capability, which means that only one DBK board within the rack system is connected to the DaqBoard, and all other DBK boards are daisy-chained together (see diagram).

In the example system described here, one CA-195 connects the DBK206 screw-terminal board to the PC, while up to 16 DBK207

analog input boards are daisy chained to the DBK206, and 8 DBK210 boards are daisy chained to the DBK206. The total I/O in such a system is 256 analog input channels (via DBK207), 256 digital I/O channels (via DBK210), plus 4 frequency inputs, 2 timer outputs, 4 analog outputs and 16 TTL digital I/O via the DBK206. All analog, digital and frequency channels can be scanned at 5 µsec/channel (in the case of digital I/O, 16 channels per 5 µsec is possible).

For applications with higher channel requirements, up to 4 DaqBoards can be installed into one PC, for a total channel capacity that is 4x a single DaqBoard system.

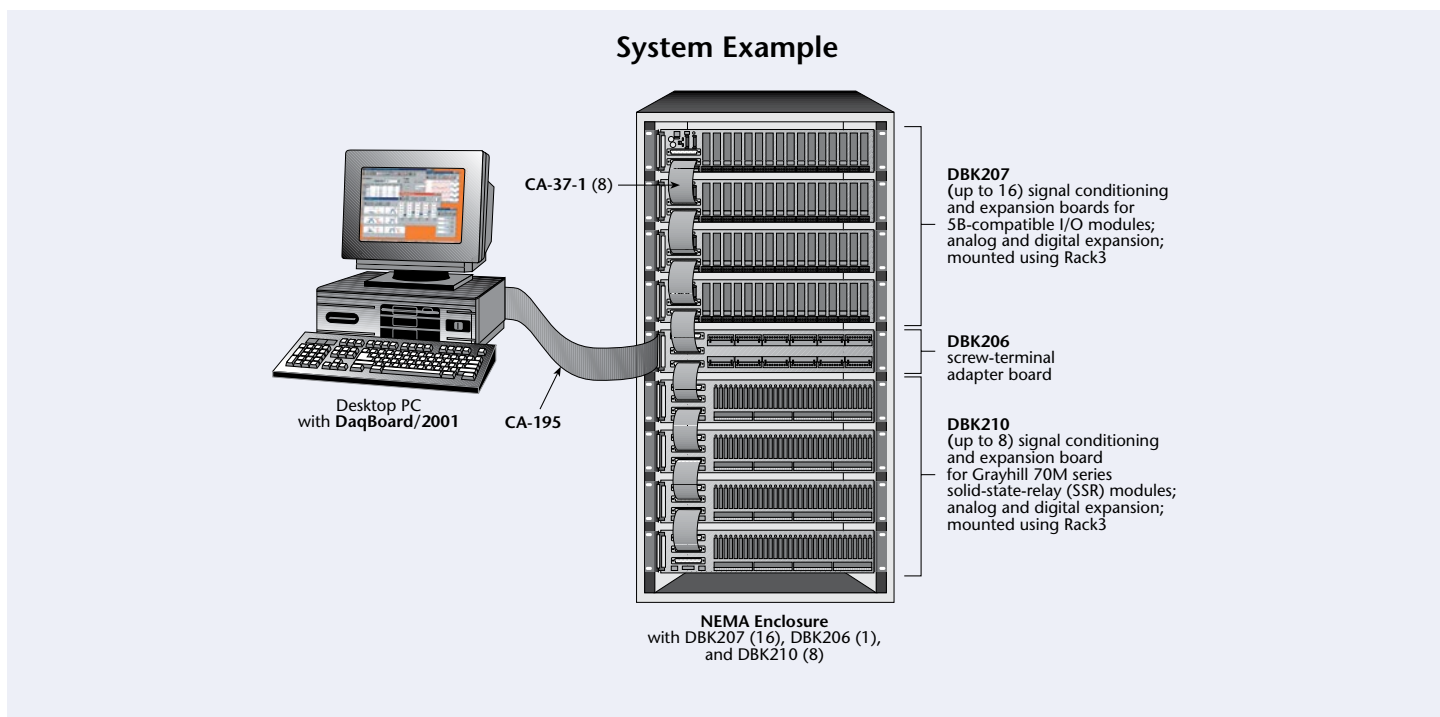

DaqBoard/2000™ Series

Expansion Options

DBK206™ Screw-Terminal Adapter

Similar in function to the DBK202, but designed for mounting in 19-inch enclosures, the DBK206 features three vertically mounted straight male DB37 connectors for analog and digital channel expansion (P1 analog I/O, P2 digital I/O, and P3 digital and counter-timer, and analog output).

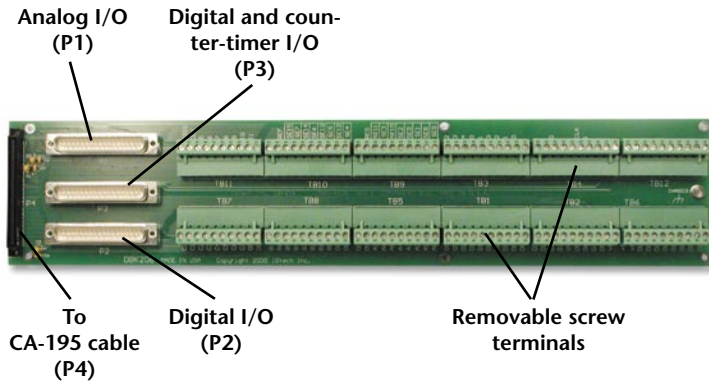

DBK208™ Multiplexing Isolated Digital I/O

The DBK208 provides sockets for 16 channels of isolated digital I/O when populated with industry standard Opto-22®-style or compatible solid-state-relay modules (sold separately).

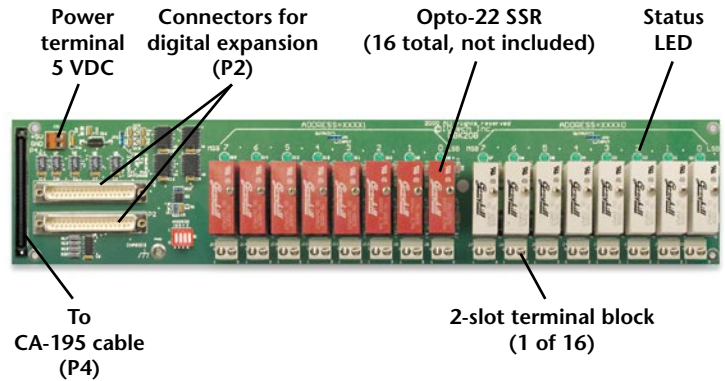

DBK207™ & DBK207/CJC™ Multiplexing Isolated Analog Input

The DBK207 provides sockets for 16 channels of isolated analog input when populated with industry standard 5B-style or compatible signal conditioning modules (sold separately).

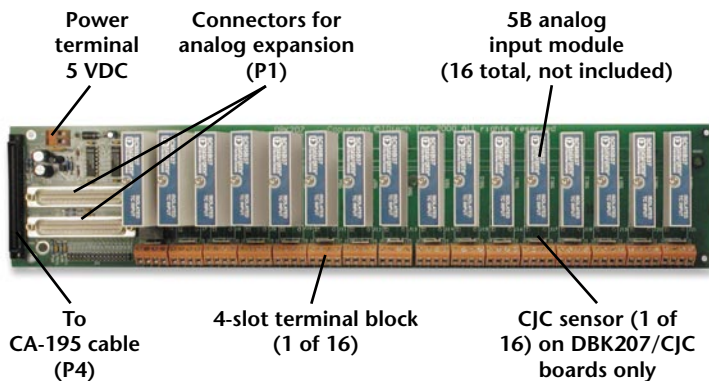

DBK210™ Multiplexing Isolated High-Density Digital I/O

The DBK210 offers similar functionality as the DBK208 but with twice the channel capacity per board. The DBK210 is the same size physically as the DBK208 but by using the Grayhill 70M series solid state relay modules (sold separately), provides space for 32 isolated digital I/O. These modules feature a narrower footprint allowing for high-density channel capacity.

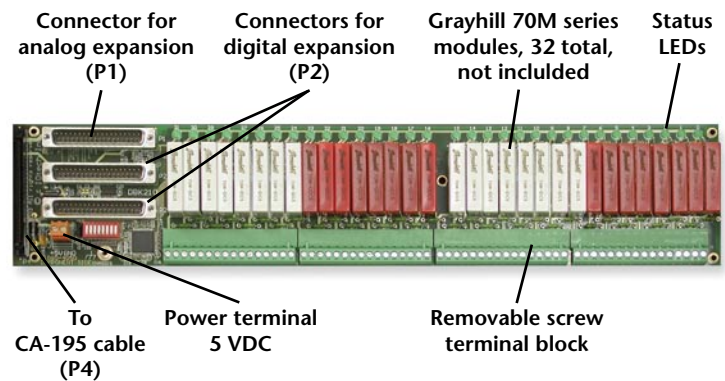

Rack3™ Rack-Mount Kit

Rack-mount kit for the DBK206, DBK207, DBK207/CJC, DBK208, DBK209, and DBK210 signal termination and expansion boards.

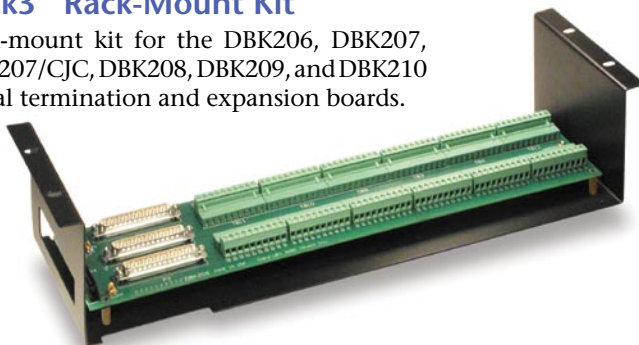

DIN1™ & DIN2™ DIN-Rail Kit

Snap-track (DIN-rail) mounting kit for the DBK206, DBK207, DBK207/CJC, DBK208, and DBK210 signal termination and expansion boards. Specify DIN2 for DBK209 only.



DaqBoard/2000™ Series

Specifications



Specifications

General (all boards)

Power Consumption (per board): 3.5W (up to 10W with external accessories), 5V PCI, contact factory for 3.3V bus support
Power Available for External Signal Conditioning and Expansion Options: 5V at 1A (all boards); ±15V at 75 mA each (except for /2002)
Operating Temperature: 0° to +60°C
Vibration: MIL STD 810E
Signal I/O Connector: 100-pin high-density edge-type carries all analog and digital I/O signals
Dimensions: 165 mm W x 15 mm D x 108 mm H (6.5" x 0.6" x 4.2")

Analog Inputs (/2000, /2001, & /2005)

Channels: 16 single-ended or 8 differential, programmable on a per-channel basis as single-ended or differential and unipolar or bipolar
Expansion: Up to 256 channels per board (4 boards per PC), without degradation in maximum channel-to-channel scan rate (5 µs/channel)
Bandwidth: 500 kHz
Settling Time: 5 µs to 1 LSB for full-scale step
Maximum Input Voltage: ±11V relative to analog common
Over-Voltage Protection: ±35V
Ranges: Software or sequencer selectable on a per-channel basis
Input Impedance: 10M Ohm single-ended, 20M Ohm differential

Voltage Range*	Accuracy** One Year, 0-35°C (% reading+% range)
	Absolute
0 to +10V	0.015 + 0.005
0 to +5V	0.015 + 0.005
0 to +2.5V	0.015 + 0.005
0 to +1.25V	0.015 + 0.008
0 to +0.625V	0.015 + 0.008
0 to +0.3125V	0.015 + 0.008
-10 to +10V	0.015 + 0.005
-5 to +5V	0.015 + 0.005
-2.5 to +2.5V	0.015 + 0.005
-1.25 to +1.25V	0.015 + 0.005
-0.625 to +0.625V	0.015 + 0.008
-0.3125 to +0.3125V	0.015 + 0.008
-0.156 to +0.156V	0.02 + 0.008

* Specifications assume differential input single channel scan, 200-kHz scan rate, unfiltered

** Accuracy specification is exclusive of noise

A/D Specifications

(/2000, /2001, & /2005)
Type: Successive approximation
Resolution: 16 bit
Conversion Time: 5 µs
Maximum Sample Rate: 200 kHz
Nonlinearity (Integral): ±1 LSB
Nonlinearity (Differential): No missing codes

Input Sequencer (/2000, /2001, & /2005)

Analog, digital and counter inputs can be scanned synchronously, based on either an internal programmable timer, or an external clock source. Analog and digital outputs can be synchronized to either of these clocks.

Scan Clock Sources: 2

1. Internal, programmable from 5 µs to 5.96 hours in 1 µs steps
2. External, TTL level input up to 200 kHz max

Programmable Parameters per Scan: Channel (random order), gain, unipolar/bipolar

Depth: 512 location

On-Board Channel-to-Channel Scan Rate: 5 or 10 µs per channel, programmable

Expansion Channel Scan Rate: 5 or 10 µs per channel, programmable

External Acquisition Scan Clock Input (/2000, /2001, & /2005)

Maximum Rate: 200 kHz
Clock Signal Range: 0V to +5V
Minimum Pulse Width: 50 ns high, 50 ns low

Triggering

Trigger Sources: 6, individually selectable for starting and stopping an acquisition. Stop acquisition can occur on a different trigger source other than start acquisition, and can be triggered via modes 2, 4, 5, or 6. Pre-trigger is supported with fixed or variable pre-trigger periods.

1. Single-Channel Analog Hardware Trigger
Latency: 5 µs max (/2000, /2001, & /2005)
2. Single-Channel Analog Software Trigger
Latency: One scan period max (/2000, /2001, & /2005)
3. Single-Channel Digital Trigger
Latency: 5 µs max (/2000, /2001, & /2005)
4. Digital Pattern Triggering
Latency: One scan period max (/2000, /2001, & /2005)
5. Counter/Totalizer Triggering
(/2000, /2001, & /2005)
Latency: One scan period, max (all boards)
6. Software Triggering (all boards)
Trigger can be initiated under program control.

Analog Outputs (/2000, & /2001)

The two or four analog output channels are updated synchronously relative to scanned inputs, and clocked from either an internal onboard clock, or an external clock source. Analog outputs can be updated asynchronously, independent of any other scanning in the system. Bus Mastering DMA provides CPU and system-independent data transfers, ensuring accurate outputs independent of other system activities. Streaming from disk or memory is supported, allowing continuous waveform outputs (limited only by available PC system resources).

Channels: 2 (/2000); 4 (/2001)

Resolution: 16 bits

Output Voltage Range: ±10V

Clock Sources: 4, programmable

1. Onboard D/A clock, independent of scanning input clock
2. Onboard scanning input clock (/2000, & /2001)
3. External D/A input clock, independent of external scanning input clock
4. External scanning input clock (/2000, & /2001)

Digital I/O (/2000, /2001, /2005)

Channels: 40, expandable up to 208 with DBK options

Input Scanning Modes: 2, programmable

1. Asynchronous, under program control at anytime
2. Synchronous with input scanning

Ports: 3 x 8-bit (82C55 emulation), and 1 x 16-bit. Each port is software programmable as input or output

Input Characteristics: 100 Ohm series, 20 pF to common

I/O Levels: TTL

Sampling/Update Rate: 200 kHz max

Output Characteristics: Output 12 mA per pin, 200 mA total continuous (per bank of 40 outputs)

Pattern Generation Output (/2000, /2001, & /2005)

The P3 16-bit digital I/O port can be configured for 16-bit pattern generation. The pattern can be updated synchronously with an acquisition.

Counter (/2000, /2001, & /2005)

Counter inputs can be scanned synchronously along with analog and digital scanned inputs, based either on internal programmable timer, or an external clock source. Counter can also be read asynchronously.

Channels: 4 x 16-bit; cascadable as 2 x 32-bit

Frequency Measurement Rate: 10 MHz max

Trigger Level: TTL

Frequency/Pulse Generators (/2000, /2001, & /2005)

Channels: 2 x 16-bit

Output: 1-MHz base rate divided by 1 to 65,535 (programmable)

DaqBoard/2000™ Series

Ordering Information

Ordering Information

Description	Part No.
16-bit, 200-kHz data acquisition board for PCI-bus PCs with 16 analog inputs, two 16-bit, 100-kHz analog outputs, 40 digital I/O, four 16-bit counter-timers, and two 16-bit frequency/pulse generators; includes DaqView and DaqCal software; support for Visual Studio® and Visual Studio® .NET, plus comprehensive drivers for DASyLab®, LabVIEW®, and MATLAB®; Linux support also available	DaqBoard/2000
Same as DaqBoard/2000 but with four 16-bit, 100-kHz analog outputs	DaqBoard/2001
Same as DaqBoard/2001 but with no analog outputs	DaqBoard/2005

Accessories

Adapter board, directly connects DBK signal conditioning and expansion options (P1, analog only) to a CA-195 or CA-209 expansion cable	DBK200
Adapter board with screw terminals, also connects DBK signal conditioning and expansion options to a CA-195 or CA-209 expansion cable	DBK202
Same as DBK202 but housed in a shielded metal enclosure	DBK203A
Termination and expansion board with removable screw terminals for access to all DaqBoard/2000 series I/O with direct connection for DBK signal conditioning and expansion options (P1, P2, and P3 for analog and digital I/O) via CA-37-1 cable(s); connects to DaqBoard/2000 series P4 connector via a CA-195 or CA-209 cable	DBK206

Description	Part No.
Termination and (P1) expansion board with fixed screw terminals and sockets for up to 16 multiplexed 5B-compatible isolated analog input modules; connects to DaqBoard/2000 series (P4) connector via a CA-195 or CA-209 cable and to LogBook or DaqBook series devices (P1) connector via CA-37-1	DBK207
Same as DBK207 but with on board, cold-junction compensation and two (P1) expansion ports	DBK207/CJC
Termination and expansion board with fixed screw terminals (12 to 26 AWG wire), sockets for up to sixteen Opto-22®-compatible isolated solid-state-relay (SSR) digital I/O modules, and status LEDs per channel; connects to DaqBoard/2000 series P4 connector via a CA-195 or CA-209 cable	DBK208
Adapter board, connects all DBK signal conditioning and expansion options to a CA-195 or CA-209 expansion cable; rack and DIN-rail mountable with optional kits	DBK209
32-channel isolated high-density digital I/O board	DBK210
Screw-terminal and expansion card module; accommodates up to three DBK signal conditioning and expansion cards	DBK213
16-connector BNC interface module with internal screw-terminal connections	DBK214
Rack-mount kit for DBK206, DBK207, DBK207/CJC, DBK208, DBK209, and DBK210 signal termination and expansion boards	Rack3
DIN-rail adapter kit for DBK206, DBK207, DBK207/CJC, DBK208, and DBK210 signal termination and expansion boards	DIN1
DIN-rail adapter kit for DBK209 signal termination and expansion board	DIN2

Cables

Description	Part No.
Expansion-card cable for connecting DBK series expansion options; specify number of option cards (x) to be connected	CA-37-x
100-conductor expansion cable, mates with the DaqBoard/2000 series boards and the DBK200, DBK202, DBK203A, DBK206, DBK207, DBK207/CJC, DBK208, DBK209, and DBK210;	
3 ft. expansion cable	CA-195
6 ft. expansion cable	CA-195-6
Same as CA-195 with CE compliance; 3 ft.	CA-209
Molded expansion cable from DaqBook to DBK modules; 2 in.	CA-255-2T
Molded expansion cable from DaqBook to DBK modules; 4 in.	CA-255-4T

Software

DaqView add-on for seamless execution with Microsoft Excel's tool palette	DaqViewXL/Plus
DaqView add-on includes all of the features of DaqViewXL/Plus, plus frequency-domain analysis	DaqView/Pro
Icon-based data acquisition, graphics, control, and analysis software	DASyLab

BUY NOW!

For complete product specifications, pricing, and accessory information, call 1-888-714-3272 (U.S. only) or visit iotech.com.