



ChartScan/1400™

Voltage and Temperature Recorder



ChartScan/1400™

- Paperless chart recorder
- Connects to PC via RS-232/422 interface
- Capable of stand-alone operation

Features

- Measure isolated temperature, DC volts, AC volts, and waveforms in one compact instrument
- Convenient signal connectivity; recessed safety jack, or subminiature plug connections
- Expandable up to 64 channels
- Single-channel burst mode for digitizing waveforms at rates up to 20 kHz
- 32 alarm outputs & 8 digital inputs
- Two programmable scan rates for:
 - pre- an post-trigger sampling
 - accelerated sampling on-event detection
- 128 Kreadings of memory
- Built-in real-time clock:
 - synchronizes acquisition to time of day
 - provides time and date stamping for trend monitoring
- RS-232 interface standard

Software

- **ChartView™ Out-of-the-Box™** scrolling strip-chart application for effortless, real-time display
- **eZ-PostView™** included free with **Out-of-the-Box™** application software

The **ChartScan/1400™** is a compact voltage and temperature recorder that can be used as a paperless chart recorder or as a data logging and control instrument. The convenient safety jack, subminiature plug, and screw-terminal connectors make signal connection easier than other data recorders or loggers. The system offers high-speed, high-channel counts, voltage isolation, and user-selectable signal conditioning.



ChartScan/1400 provides measurement and control

ChartScan/1400

The **ChartScan/1400** is a next-generation recorder that combines the ease-of-use common in paper-based strip-chart recorders with the advanced features of PC-based data acquisition systems. The **ChartScan** offers distinct advantages over typical chart recorders. For example, it is not prone to mechanical failure like conventional paper-based recorders with chart drives, paper feeds, moving pens, and knobs.

Unlike other hybrid recorders—which are often handicapped by difficult menu systems, low-visibility LCD displays, and inconvenient multi-purpose keypads—the **ChartScan/1400** features Windows®-based **Out-of-the-Box™** **ChartView** software for easy setup, acquisition, and real-time display.

ChartView™ Software

The **ChartScan/1400** includes **ChartView**, one of IOtech's **Out-of-the-Box™**, Windows-based setup and acquisition applications. **ChartView** provides a graphical spreadsheet-style user interface that lets you easily configure your hardware, acquisition, and display parameters. **ChartView** features a *no*



The ChartScan/1400 portable recorder is ideal for making isolated temperature and voltage measurements (notebook PC not included)

programming approach that enables data collection and display within minutes of taking the **ChartScan/1400 Out-of-the-Box™**. Optional **ChartView Plus™** adds expanded display and recording capabilities.



ChartScan/1400™

General Information

Isolated Inputs

The **ChartScan/1400** is ideal for temperature and voltage measurements that require channel-to-channel isolation. The systems provides 500V isolation for high-voltage applications using the CSN14/HVX/S module and 200V isolation when the thermocouple and other voltage modules are used. The systems achieve this high isolation by using individual relays on each channel, yet still maintain a very fast 147 channels/s scan rate.

Faster Scanning

The **ChartScan/1400** offers faster scanning than a typical strip-chart recorder, and exceeds the typical two Hz rate found on most strip-chart, multi-point, or hybrid recorders. The unit provides an array of scanning capabilities to meet your application requirements. Because data-logging and chart recording applications frequently require logging at fixed time intervals, the system uses the standard hours-minutes-seconds (hh:mm:ss.s) format to specify the time interval between channel scans. Users can configure the unit to begin and end data logging on a specified event such as a TTL signal, temperature level, alarm condition, absolute time of day, or upon completion of a specified number of readings.

Programmable Scan Rates. The **ChartScan/1400** offers programmable scan rates for applications requiring acceleration of the measurement rate on a specified event, such as an alarm condition. For example, you can program the instrument to scan once per minute and then, upon the occurrence of a specified alarm condition, switch to scanning once per second. Upon cessation of the alarm condition, the unit resumes scanning at the rate of once per minute.

Scanning Techniques

The **ChartScan/1400** offers three measuring modes for application flexibility. These include a line-cycle integration mode, a high-speed multichannel scanning mode, and a single-channel burst mode. A discussion of the particular attributes of each measuring mode follows.

Line-Cycle Integration. The ability to sample and average 32 measurements per line cycle over multiple line cycles, makes the systems useful for high-accuracy applications and thermocouple measurements in applications subject to high AC noise environments. When engaged in line-cycle averaging, the unit provide AC or DC voltage, or linearized and compensated thermocouple-based temperature readings at up to 44 channels/s. The AC voltage measurement capability is ideal for power-line monitoring applications. For each measurement, the unit calculates the equivalent true RMS voltage based on 32 samples it acquires during each AC line cycle.

High-Speed Multichannel Scanning. When line-cycle averaging is disabled, the system can average 1, 2, 4, 8, or 16 samples per

Feature	ChartScan/1400
Measurement Parameters	
A/D resolution	16 bit w/oversampling
Accuracy (w/) thermocouple)	±0.5°C
Thermocouples supported	J,K,T,E,R,S,B,N
Voltage input	±100 mV to 250V
Channel-to-channel isolation	up to 500V
Channel-to-system isolation	500V
Scanning Parameters	
Switching technology	mechanical relays
Max scan rate	147 channels/s
Max single-channel scan rate	20 kHz
Min channel configuration	16 channels
Max channel configuration	64 channels
Data Handling	
Built-in memory	128 Kreadings
Max memory with expansion	4 Mreadings
RS-232 interface	✓
Time & date stamping	✓
Triggering	
Digital trigger input	✓
Analog trigger input	✓
Trigger on time of day	✓
Pre-trigger scan rate	programmable
Post-trigger scan rate	programmable
Digital Inputs	8
Programmable Alarm Outputs	32
Software	
ChartView	included
ChartView Plus	optional
ChartViewXL	included
eZ-PostView	included
LabVIEW driver	included
Hardware Options	
16-ch isolated TC/voltage scanning module	✓
16-ch isolated low-voltage scanning module	✓
16-ch isolated high-voltage scanning module	✓

channel. When the unit is configured to take 1 sample per channel, it can scan 147 channels/s or all 64 channels in under a half second. This is important when trying to time-correlate a large number of channels. By contrast, data loggers and other temperature measuring instruments typically acquire readings at only 5 to 20 channels/s.

Line Cycle Integration					
Line Cycles per Reading	DC Volts & Thermocouples		AC Volts		Maximum Channel Number
	50 Hz	60 Hz	50 Hz	60 Hz	
1	38.5*	44*	38.5*	44*	128
2	19.2*	22*	—	—	128
4	9.6*	11*	—	—	128
8	4.8*	5.5*	—	—	122

* channels/s

Single-Channel Burst Mode. In single-channel burst mode, the system can sample at up to 20 kHz on a single channel and store the data in memory. When performing post-acquisition waveform analysis such as Fast Fourier Transforms (FFTs), the unit can return each data point in a waveform to your program. Alternatively, the unit can provide a true RMS value of the sampled voltage.



ChartScan/1400™

General Information

Accuracy

The **ChartScan/1400** has a number of features and capabilities that enable it to deliver the high accuracy demanded by many research applications.

High Resolution. The system is equipped with a high-speed 16-bit A/D converter. This enables the system to offer up to 0.1°C and 3.05 µV resolution with the CSN14/TC/P thermocouple/volt scanning module.

Noise Filtering. The system reduces noise by sampling and averaging 32 measurements per line cycle. The system also offers the flexibility to average across multiples of 1, 2, 4, or 8 line cycles.

High-Accuracy Cold Junction Compensation. The CSN14/TC/P thermocouple/volt scanning module features multiple, strategically located temperature sensors that provides high-accuracy, cold junction compensation across all inputs.

Accurate Linearization. The system enables quick and accurate linearization by providing built-in lookup tables for popular thermocouple types, including J, K, T, E, R, S, B, and N.

Alarms

Detecting an alarm condition is a common requirement in logging applications and the **ChartScan/1400** offers a number of modes to facilitate alarm detection. With 32 digital TTL alarm outputs available on the 50-pin rear panel connector multiple conditions can be set and monitored. Unlike some instruments which allow only one channel to be assigned to a single alarm output, the ChartScan/1400 allows one or more channels to be logically "OR-ed" and connected to an alarm output. In this way, all 64 channels can participate in the alarm process. Channel settings for alarm limit and hysteresis are individually set with the alarm output remaining high for as long as the alarm condition is valid.

The units' ability to automatically update alarm outputs in real time affords you greater control of your applications and reduces your programming burden by eliminating the need for constant per-channel monitoring by the controlling computer.

In addition, the ChartScan/1400 can update alarmed output channels in real time, at their programmed scan rates, and can alert the host computer of active alarm conditions.

Typical Expansion Module Block Diagram

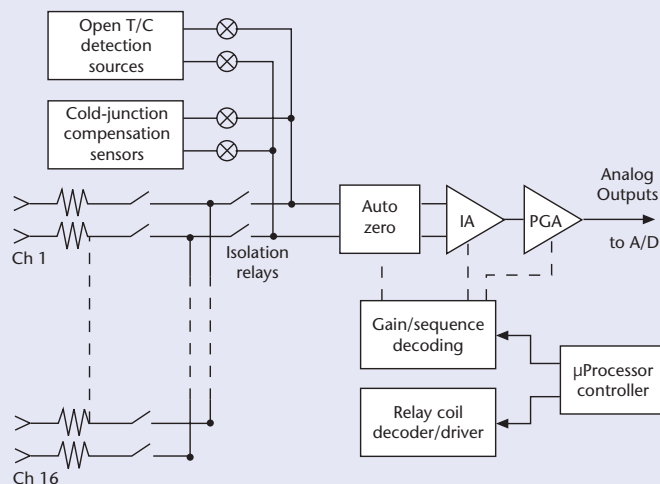

Real-Time Clock

The **ChartScan/1400** features a real-time clock that allows you to synchronize acquisition to a specific time of day. During acquisition, the system stores the time and date of every data scan in memory, enabling later retrieval of this information for use in plotting and analyzing measurements. The instrument also time and date stamps each channel's high and low excursions, providing a precise time record of a channel's minimum and maximum values.

Memory

For high-speed and long-term data logging, the systems are equipped with 128 Kreadings of data storage. Since each application requires different measurements, each channel's high, low, and last readings are available throughout acquisition. A 4 Mreading memory option is also available.

ChartScan Communication

Connecting your computer to the **ChartScan/1400** is simple via the standard RS-232/422 interface. For long distances, ChartScans also support any Hayes-compatible modem.



ChartScan/1400™

Scanning Modules

Temperature & Voltage Modules

Input modules are ideal for making isolated temperature and voltage measurements. Each features 16 isolated inputs and plugs directly into the [ChartScan/1400](#).

Depending upon the module and signal input, cards have either safety jack, or thermocouple plugs for quick and easy input connections. The modules slide into a shielded metal enclosure within the [ChartScan/1400](#), keeping noise to a minimum and maintaining a stable internal temperature for accurate Cold Junction Compensation (CJC) reading.

All scanning modules feature isolated, differential input capabilities that can make accurate measurements in high common-mode voltage applications. Each relay-isolated channel can be scanned at up to 147 channels/s. In that time, all channels are logged to memory, high/low/last registers are updated, alarms are reported, and thermocouple inputs are cold junction compensated and linearized. Modules can be mixed to match your application.

ChartScan/1400 Modules			
Model	Type	Input	Connector Type
CSN14/TC/P	T/C and Voltage	J, K, T, E, R, S, B, N, ±10V, ±5V, ±1V, and ±100 mV	Subminiature Plug
CSN14/LV/T	Low Voltage	±10V, ±5V, ±1V and ±100 mV	Screw Terminal
CSN14/HVX/S	High Voltage	±2.5V, ±25V, and ±250V	Safety Jack

Temperature Scanning

The [ChartScan/1400](#) scans the most popular thermocouple types and voltages up to ±10V using the CSN14/TC/P 16-channel thermocouple and voltage module. Convenient subminiature plugs are used for signal input.



CSN14/TC/P 16-channel thermocouple and voltage scanning module

Voltage Scanning

To meet your application needs, the low-voltage scanning module supports the most popular connectors used today. The low-voltage option (up to ±10V) is



CSN14/LV/T 16-channel low-voltage scanning module with removable screw-terminal inputs

available with safety-jack inputs. The high-voltage (up to ±250V) scanning module also features safety-jack inputs.



*CSN14/HVX/S 16-channel high-voltage scanning module with safety-jack input; 500 VDC max common mode voltage**

* 200V when used with CSN14/TC/P



ChartScan/1400™

Specifications

Specifications

Number of Slots: 4
Number of Channels: Up to 64 differential thermocouple or voltage inputs; accepts CSN14/TC/P, CSN14/LV/S, and CSN14/HVX/S scanning modules
Channel Attributes: High and low set points; hysteresis value for high & low set points
A/D Resolution: 16 bits
Scan Sequence: Any combination of temperature and voltage channels may be scanned in ascending numerical order
Scan Interval: Relative time between channel scans; minimum = 6.8 ms; maximum = 99:59:59.9 (hh:mm:ss.s)

Scanning Rates

Multichannel: Rates up to 147 channels/s (50/60 Hz)
32 point averaging: 44 channels/s (60 Hz); 38.5 channels/s (50 Hz),
Single Channel Burst: 20 Ksamples/s, single-channel burst mode

Programmable Triggering

Trigger Criteria: Temperature or voltage above or below a level, absolute time of day, alarm condition (on or off), external TTL trigger (level high or level low), specified number of readings
Level Trigger: Programmable value for any one channel*
TTL Trigger: Programmable for high or low level
Pre-Trigger Count: Programmable (<128K - 1)
Post-Trigger Count: Programmable

Alarms & Digital I/O

Number of Digital Alarm Outputs: 32 TTL-level compatible
Number of Digital Inputs: 8 bits, TTL compatible
Connector: 50-pin D-connector; mating connector supplied
Alarm Conditions: Can be detected by software query

Data Storage & Format

Storage: 128 Kreadings standard
Data Formats: ASCII or binary; binary format returns a 16-bit compensated and linearized temperature value (0.1°C/bit); user programmable for hi byte/lo byte or lo byte/hi byte
Note: High-speed DMA transfers use binary format only
Statistical Parameters: High, low, and last available per channel
Time Stamp: Available for each scan group and for each channel's high, low, and last parameters*

Time Format

1. Absolute date and time (mm/dd/yy hh:mm:ss.s)
2. Relative time (±hh:mm:ss.s)

RS-232/422 Interface

Baud Rates: 300, 2400, 4800, 9600, 19200
Data Bits: 8
Stop Bits: 1
Parity: Even, odd, none
Handshaking: RTS/CTS, XON/OFF
Connector: Male DB-9

Calibration

Calibration Cycle: One year
Calibration Constants: Chassis constants stored in nonvolatile memory; card constants stored in EEPROM; each unit includes ScanCal, example software for automating its calibration procedure; calibration is enabled via software password and by hardware enable switch

General

Indicators: LEDs for alarm, scanning, error, send, receive, power, and trigger status
Power: 105 to 125 or 210 to 250 VAC, 50/60 Hz; 20 VA max
Warm-Up: One hour to rated accuracy
Environment: 0° to 50°C; 0 to 95% RH, non-condensing to 35°C; linearly derate 3% RH/°C from 35°C to 50°C
Digital I/O and Alarms: Female DB50 (32 alarms, 8 digital inputs, 10 ground pins)
Trigger Input: BNC
TTL Output: BNC
Dimensions: 330 mm W x 241 mm D x 152 mm H (13" x 9.5" x 6")
Weight: 4.3 kg (9.6 lbs)

Scanning Module Specifications CSN14/TC/P 16-Channel Thermocouple and Voltage Scanning Module

Number of Channels: 16 differential; programmable by channel for specific thermocouple type or voltage input
Inputs: J, K, T, E, R, S, B, N, ±10V, ±5V, ±1V and ±100 mV
Input Connectors: Subminiature plug
Maximum Allowable Input: ±25V rms
Input Impedance: 1M Ohm
Input Bias Current: 20 nA max
Maximum Common Mode Voltage^{1,2}: 200 VDC or AC peak
Maximum Normal Mode Voltage: 10 VDC or AC peak
Channel-to-Power Ground Isolation: 200 VDC or AC peak
Channel-to-Channel Isolation: 200 VDC or AC peak
Temperature Coefficient: <(0.1 x rated accuracy)%/°C
Line Cycle Noise Rejection: Software enabled for the averaging of 1 through 255 samples over multiple AC line cycles

Temperature Specifications

Type	Range	Accuracy ^{3,4}
J	-100° to +760°C	±0.5°C
	-200° to -100°C	±0.8°C
K	-100° to +1372°C	±0.6°C
	-200° to -100°C	±0.8°C
T	-100° to +400°C	±0.5°C
	-200° to -100°C	±0.8°C
E	-100° to +1000°C	±0.7°C
	-200° to -100°C	±0.9°C
R	0.0° to +1780°C	±2.0°C
S	0.0° to +1780°C	±2.0°C
B	+350° to +1820°C	±2.0°C
N	-100° to +1300°C	±0.6°C
	-200° to -100°C	±0.9°C

Units: °C, °F, °K, °R, mV & Volts
Fault Detection: Open thermocouple can be detected by software query
Cold Junction Sensors: One for every 4 input channels
Linearization: Performed by lookup table

* Not available when using single-channel burst mode

1. Specified for coupling impedance > 30M Ohm and common mode frequency < 60 Hz
2. 300 VDC or AC peak before equipment damage occurs
3. 18° to 28°C, 1 year; includes cold junction compensation
4. Typical; excludes thermocouple errors
5. Add ±5°C for common mode voltages greater than 25 VAC
6. Maximum peak-to-peak signal for AC volts
7. For AC voltages where the frequency of the input signal is an integer multiple of the AC line cycle ±1%
8. 700 VDC or AC peak before equipment damage occurs
9. 325 VDC or AC peak if used in the same system with the CSN14/TC/P scanning module
10. With line cycle integration enabled



ChartScan/1400™

Specifications & Ordering Information

AC/DC Voltage Specifications

Range and Resolution

Range ⁶	Resolution
±100 mV	3.05 µV/bit
±1V	30.5 µV/bit
±5V	153 µV/bit
±10V	306 µV/bit

Accuracy: ±0.02% of range^{7,10}

CSN14/LV/T 16-Channel Isolated Low-Voltage Scanning Module with Screw-Terminal Input

Number of Inputs: 16 differential; programmable by channel for specific input range

Input Connectors: Safety jack

Range and Resolution³

Range ⁶	Resolution
±100 mV	3.05 µV/bit
±1V	30.5 µV/bit
±5V	153 µV/bit
±10V	306 µV/bit

Accuracy: ±0.02% of range^{7,10}

Line Cycle Noise Rejection: Software enabled for the averaging of 1 through 255 samples over multiple AC line cycles

Maximum Common Mode Voltage^{1,2}: 200 VDC or AC peak

Input Impedance: 1M Ohm

Input Bias Current: 20 nA max

Maximum Normal Mode Voltage: 10 VDC or AC peak

Common Mode Rejection: 100 dB typ

Maximum Allowable Input: ±25 Vrms

Channel-to-Power Ground Isolation: 200V peak

Channel-to-Channel Isolation: 200V peak

Temperature Coefficient: < (0.1 x rated accuracy)%/°C

CSN14/HVX/S 16-Channel Isolated High-Voltage Scanning Module

Number of Inputs: 16 differential; programmable by channel for any input range

Input Connectors: Safety jack

Range and Resolution³

Range ⁶	Resolution
±2.5V	78.14 µV/bit
±25V	781.4 µV/bit
±250V	7.814 mV/bit

Accuracy: ±0.02% of range^{7,10}

Digital Filtering: Averages 32 samples at 50/60 Hz for line-cycle noise rejection (DCV measurements)

Temp Coefficient: <0.01%/°C

Input Impedance: 10M Ohm

Input Bias Current: 20 pA max

Maximum Common Mode Voltage^{1,8,9}: 500 VDC or AC peak

Maximum Normal Mode Voltage: 500 VDC or AC peak

Common Mode Rejection: 100 dB typ

Maximum Allowable Overload-to-Channel Input: 400 VDC

Channel-to-Power Ground Isolation: 500V peak

Maximum Channel-to-Channel Voltage: 50V peak⁹

Ordering Information

Description	Part No.
High-speed isolated temperature and voltage measurement instrument, includes RS-232 interface; ChartView™ and eZ-PostView™ software; and DB50 digital I/O port mating connector	ChartScan/1400*
16-channel thermocouple/volt scanning module	CSN14/TC/P
16-channel high-voltage scanning module with safety-jack connectors; 500 VDC max common mode voltage	CSN14/HVX/S
16-channel low-voltage scanning module with removable screw-terminal inputs	CSN14/LV/T
8 Mbyte (4 Mreading) memory module	MEMX7

Male Connectors for Subminiature TC Jacks

Type J for CSN14/TC/P	CN-144-JM
Type K for CSN14/TC/P	CN-144-KM
Type T for CSN14/TC/P	CN-144-TM
Copper to copper male connector	CN-144-UM

Cables

Description	Part No.
RS-232 serial port cable (9- and 25-pin sub D) to (9-pin sub D) for the ChartScan/1400, 6 ft.	CA-47
Cables, probe, and alligator clips for safety jack input	CA-161

Software

ChartView Plus™	ChartView Plus
-----------------	----------------

For complete information on accessories and cables, visit www.iotech.com/acc

Related Products

Software
ChartView (included)
ChartView Plus

(Refer to previous page for numbered references)

* Scanning modules must be ordered separately