

EKI-6333AC-2G Series

IEEE 802.11 a/b/g/n/ac Wi-Fi AP



Features

- Supports 802.11n MIMO 2T2R
- WLAN transmission rate up to 867 Mbps
- Supports secure access with WEP, 802.1x, WPA/WPA2-Personal, WPA/WPA2-Enterprise
- Provides Web-based configuration
- Supports dual bands 2.4G/5G concurrent

Introduction

The EKI-6333AC-2G is a feature-rich wireless AP providing reliable wireless connectivity for industrial environments. The PoE injector enhances flexibility in deployment of this AP even where the DC power supply is hard to fulfill. As a 802.11n compliant device, EKI-6333AC-2G provides a data rate that is six times higher than legacy 802.11g devices.

With the support of STP, WMM and IGMP snooping protocols, EKI-6333AC-2G improves the reliability of wireless connectivity, especially in applications requiring high reliability and throughput data transmission. To secure the wireless connection, EKI-6333AC-2G implements the latest encryption technologies, including WPA2/WPA/802.1x for powerful security authentication.

Specifications

Ethernet Communications

- **Port Type** RJ45
- **No. of Ports** 2
- **Speed** 10/100/1000 Mbps

Wireless LAN Communications

- **Compatibility** 2.4GHz: IEEE 802.11 b/g/n
5GHz: IEEE 802.11 a/n/ac
- **Speed** Up to 867Mbps
- **Network Mode** Infrastructure
- **Free Space Range** Open space 100 m
- **Wireless Security** WEP, WPA/WPA2-Personal, WPA/WPA2-Enterprise

Software

- **Management** Telnet, FTP, SNMP, Web UI, SSH
- **Wireless** Radio on/off, WMM/Regatta Mode, Output Power Control, Beacon Interval, RTS/CTS threshold, DTIM Interval
- **Operation Modes** Access Point mode, Client, Repeater
- **Configuration** Web Browser
- **Protocol** ARP, ICMP, IPv4, IPv6, TCP, UDP, DHCP Client, DHCP Server, Auto IP, Telnet, DNS, SNMP, HTTP, DMZ, PPPoE, VPN Passthrough, Telnet Server, SSH Server, FTP Server, QoS

Antenna

- **Default external 5 dBi Omni antenna**
- **4 x Reverse SMA connectors for SMA antenna**

Data Rates

- **802.11b** 11M, 5.5M, 2M, 1Mbps
- **802.1111 a/g** 54M, 48M, 36M, 18M, 12M, 9M, 6Mbps
- **802.11n** HT20 MCS0-15 / HT40 MCS0-15

Mechanics

- **Enclosure** Plastic
- **Mounting** Wall, Pole
- **Dimensions (W x H x D)** 191.6 x 114.3 x 47.7 mm (7.54" x 4.49" x 1.88")
- **Weight** 0.5kg

General

- **LED Indicators** System: Power
WLAN: Link/Active
LAN: Link/Active
- **Reboot Trigger** Built-in WDT (watchdog timer)

Power Requirements

- **Power Input** DC 24 V / 1A; AC Adapter 100 V ~ 240 V
- **Power Connector** RJ45, Passive 24V PoE
- **Power Consumption** TBD

Environment

- **Operating Temperature** -20 ~ 70 °C (-4~158°F)
- **Storage Temperature** -30 ~ 80°C (-22 ~ 176°F)
- **Operating Humidity** 10 ~ 95% RH

Regulatory Approvals

- **EMC** CE, FCC Part 15 Subpart B

Dimensions

Unit: mm [inch]

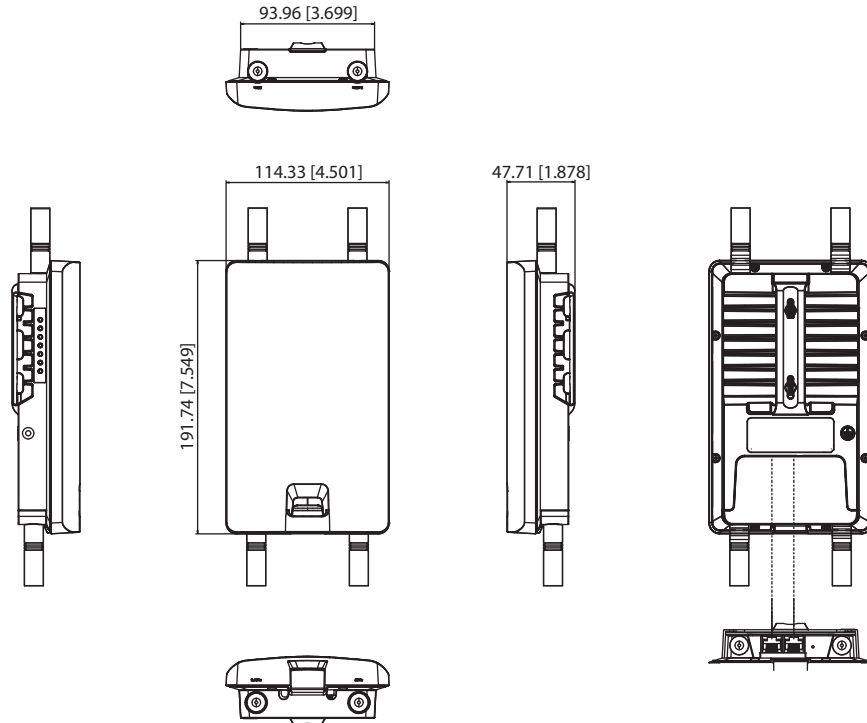

Panel Cut-out Dimensions: 114.33 x 191.74 x 47.71 mm (4.5" x 7.5" x 1.8")

Ordering Information

- EKI-6333AC-2G 802.11 a/b/g/n/ac Wireless AP/Client