

EKI-2726FHPI

4 10/100/1000T + 2 1000 Mini-GBIC with 4 IEEE 802.3at High Power PoE Industrial Wide Temperature Switch

ADVANTECH

Enabling an Intelligent Planet

Copyright

The documentation and the software included with this product are copyrighted 2012 by Advantech Co., Ltd. All rights are reserved. Advantech Co., Ltd. reserves the right to make improvements in the products described in this manual at any time without notice.

No part of this manual may be reproduced, copied, translated or transmitted in any form or by any means without the prior written permission of Advantech Co., Ltd. Information provided in this manual is intended to be accurate and reliable. However, Advantech Co., Ltd. assumes no responsibility for its use, nor for any infringements of the rights of third parties, which may result from its use.

Acknowledgements

Intel and Pentium are trademarks of Intel Corporation.

Microsoft Windows and MS-DOS are registered trademarks of Microsoft Corp.

All other product names or trademarks are properties of their respective owners.

Product Warranty (5 years)

Advantech warrants to you, the original purchaser, that each of its products will be free from defects in materials and workmanship for five years from the date of purchase.

This warranty does not apply to any products which have been repaired or altered by persons other than repair personnel authorized by Advantech, or which have been subject to misuse, abuse, accident or improper installation. Advantech assumes no liability under the terms of this warranty as a consequence of such events.

Because of Advantech's high quality-control standards and rigorous testing, most of our customers never need to use our repair service. If an Advantech product is defective, it will be repaired or replaced at no charge during the warranty period. For out-of-warranty repairs, you will be billed according to the cost of replacement materials, service time and freight. Please consult your dealer for more details.

If you think you have a defective product, follow these steps:

1. Collect all the information about the problem encountered. (For example, CPU speed, Advantech products used, other hardware and software used, etc.) Note anything abnormal and list any onscreen messages you get when the problem occurs.
2. Call your dealer and describe the problem. Please have your manual, product, and any helpful information readily available.
3. If your product is diagnosed as defective, obtain an RMA (return merchandise authorization) number from your dealer. This allows us to process your return more quickly.
4. Carefully pack the defective product, a fully-completed Repair and Replacement Order Card and a photocopy proof of purchase date (such as your sales receipt) in a shippable container. A product returned without proof of the purchase date is not eligible for warranty service.
5. Write the RMA number visibly on the outside of the package and ship it prepaid to your dealer.

Part No.
Printed in Taiwan

Edition 2
August 2012

Declaration of Conformity

FCC Class A

This Equipment has been tested and found to comply with the limits for a Class-A digital device, pursuant to Part 15 of the FCC rules. These limits are designed to provide reasonable protection against harmful interference in a residential installation. This equipment generates, uses, and can radiate radio frequency energy. It may cause harmful interference to radio communications if the equipment is not installed and used in accordance with the instructions. However, there is no guarantee that interference will not occur in a particular installation. If this equipment does cause harmful interference to radio or television reception, which can be determined by turning the equipment off and on, the user is encouraged to try to correct the interference by one or more of the following measures:

- Reorient or relocate the receiving antenna.
- Increase the separation between the equipment and receiver.
- Connect the equipment into an outlet on a circuit different from that to which the receiver is connected.
- Consult the dealer or an experienced radio/TV technician for help.

CE

This is a Class-A product. In a domestic environment this product may cause radio interference in which case the user may be required to take adequate measures.

Advantech Customer Services

Each and every Advantech product is built to the most exacting specifications to ensure reliable performance in the unusual and demanding conditions typical of industrial environments. Whether your new Advantech equipment is destined for the laboratory or the factory floor, you can be assured that your product will provide the reliability and ease of operation for which the name Advantech has come to be known.

Your satisfaction is our number one concern. Here is a guide to Advantech's customer services. To ensure you get the full benefit of our services, please follow the instructions below carefully.

Technical Support and Assistance

1. Visit the Advantech web site at <http://support.advantech.com.cn> where you can find the latest information about the product.
2. Contact your distributor, sales representative, or Advantech's customer service center for technical support if you need additional assistance. Please have the following information ready before you call:
 - Product name and serial number
 - Description of your peripheral attachments
 - Description of your software (operating system, version, application software, etc.)
 - A complete description of the problem
 - The exact wording of any error messages

Contents

Chapter 1	Introduction.....	1
1.1	Overview	2
1.2	Features	2
1.3	Packing List.....	2
Chapter 2	Hardware Description	3
2.1	Physical Dimensions	4
2.1.1	LED Indicators	4
	Table 2.1: EKI-2726FHPI LED Indicators.....	4
2.2	RJ-45 Pin Assignments.....	5
Chapter 3	Installation.....	7
3.1	DIN-Rail Mounting	8
3.1.1	Assembling the DIN-Rail Clip.....	8
	Figure 3.1 Rear side of the Switch.....	8
3.1.2	Hanging the Industrial Switch	9
3.2	Wall Mounting	10
3.3	Grounding the Industrial Switch	11
3.4	Wiring the Power Inputs	11
	Figure 3.2 Plugs for Power 1 & Power 2.....	11
	Figure 3.3 Captive Screws for Fixing Wires.....	12
3.5	Wiring the Fault Alarm Contacts	12
	Figure 3.4 Terminal Block Plugs for Fault Alarm Contacts	12
	Figure 3.5 Fault Alarm Wiring Example	12
3.6	Ethernet Cabling	13
3.6.1	Connecting the SFP Port	13
	Figure 3.6 Transceiver to the SFP slot	13
	Figure 3.7 Transceiver Inserted.....	13
	Figure 3.8 LC connected to the transceiver	14
3.6.2	Disconnecting the SFP Port.....	14
	Figure 3.9 Remove LC connector.....	14
	Figure 3.10 Pull out from the SFP slot.....	14
Appendix A	Troubleshooting	15
A.1	Troubleshooting	16
Appendix B	Technical Specifications.....	17
B.1	Technical Specifications.....	18

Chapter 1

Introduction

1.1 Overview

The High-Power PoE Industrial Switch is a cost-effective solution, which meets the high reliability requirements demanded by industrial applications. To solve the inconvenience of wall outlet access, the equipment is designed with power over Ethernet ports that comply with the IEEE 802.3at standard providing power as well as data over the conventional RJ-45 cables to the connected Powered Devices which need higher power consumption.

1.2 Features

- **System Interface/Performance**
 - RJ-45 ports support Auto MDI/MDI-X Function
 - Embedded 4-port PoE Injection
 - Store-and-Forward Switching Architecture
 - Back-plane (Switching Fabric): 12Gbps
 - MAC Address Table with 8K entries
- **Power Input**
 - DC 48V Redundant Power Input
- **Case/Installation**
 - IP-30 Protection
 - Installation in a Pollution Degree 2 environment
 - DIN-rail and Wall mountings Design

1.3 Packing List

Please refer to the package contents list below to verify them against the checklist.

- PoE Industrial Switch x 1
- User manual (CD-ROM) x 1
- Removable Terminal Block x 1
- Wall-mount Kit (2 wall-mount brackets with screws) x 1

Chapter 2

Hardware Description

In this chapter, the Industrial switch's dimensions, definitions for LED indicators, cabling information, and wiring installation will be described.

2.1 Physical Dimensions

The PoE Industrial Switch dimensions (W x H x D) are 59.6mm x 152mm x 105mm as the figure shown below.

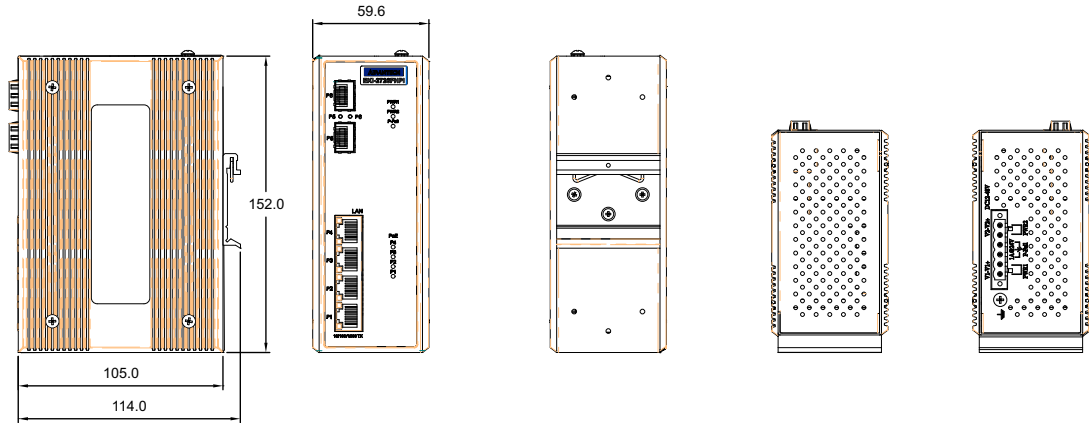

2.1.1 LED Indicators

The diagnostic LED indicators located on the front panel of the industrial switch provide real-time system information and operation status. The table below provides the description status and definitions of the LED indicators for the switch.

Table 2.1: EKI-2726FHPI LED Indicators

LED	Color	Description	
Power1	Green	On	Power input 1 is active
		Off	Power input 1 is inactive
Power2	Green	On	Power input 2 is active
		Off	Power input 2 is inactive
P-Fail	Red	On	Power input 1 or 2 has failed
		Off	No failure occurs
PoE indicator (Port 1 ~ 4)	Green	On	The port is supplying power to the powered-device
		Off	No powered-device attached or power supplying fails
1 ~ 4 (RJ-45)	Green (upper)	On	Connected to network
		Flashing	Networking is active
		Off	Not connected to network
	Green (lower)	On	1000M
Off		100/10M	
5, 6 (mini-GBIC)	Green	On	Connected to network
		Flashing	Networking is active
		Off	Not connected to network

2.2 RJ-45 Pin Assignments

The UTP/STP ports will automatically sense for Fast Ethernet (10Base-T/100Base-TX) or Gigabit Ethernet (10Base-T/100Base-TX/1000Base-T) connection. Auto MDI/MDIX means that the switch can connect to another switch or workstation without changing straight through or crossover cabling. See the figures below for straight through and crossover cable schema.

■ 10/100Base-TX Pinouts

Pin Number	Assignment
1	Tx+
2	Tx-
3	Rx+
6	Rx-

Note! "+" and "-" signs represent the polarity of the wires that make up each wire pair.



The table below shows the 10Base-T/100Base-TX MDI and MDI-X port pinouts.

Pin Number	MDI-X Signal Name	MDI Signal Name
1	Receive Data plus (RD+)	Transmit Data plus (TD+)
2	Receive Data minus (RD-)	Transmit Data minus (TD-)
3	Transmit Data plus (TD+)	Receive Data plus (RD+)
6	Transmit Data minus (TD-)	Receive Data minus (RD-)

■ 10/100Base-TX Cable Schema

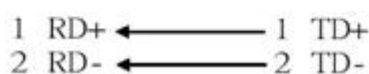
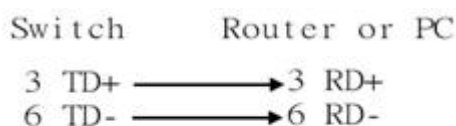

Straight Through Cable Schema

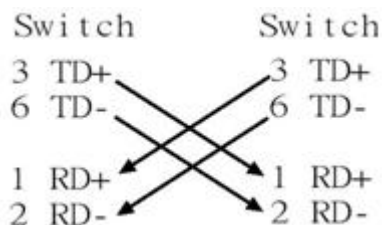

Crossover Cable Schema

■ 10/100/1000Base-T Pinouts

The table below describes the gigabit Ethernet RJ-45 pinouts.

Pin	Signal name	Description
1	BI_DA+	Bi-directional pair A+
2	BI_DA-	Bi-directional pair A-
3	BI_DB+	Bi-directional pair B+
4	BI_DC+	Bi-directional pair C+
5	BI_DC-	Bi-directional pair C-
6	BI_DB-	Bi-directional pair B-
7	BI_DD+	Bi-directional pair D+
8	BI_DD-	Bi-directional pair D-

■ 10/100/1000Base-T Cable Schema

The following two figures illustrate the 10/100/1000Base-T cable schema.

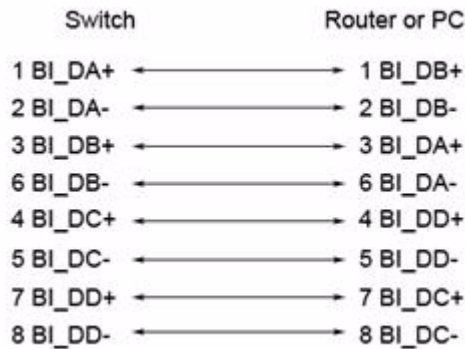

Straight Through Cable Schema

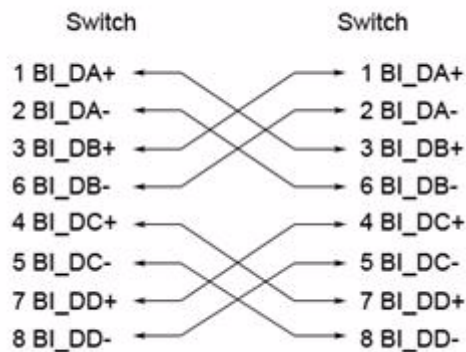

Crossover Cable Schema

Chapter 3

Installation

- Caution!** 1. This equipment is intended for use in a Pollution Degree 2 industrial environment.
2. This equipment is intended for installation in an industrial control panel.



3.1 DIN-Rail Mounting

3.1.1 Assembling the DIN-Rail Clip

The DIN-rail clip is screwed on the industrial switch when out of factory. If not, please refer to the following steps to secure the DIN-rail clip on the switch.

1. Use the included screws to secure the DIN-rail clip on the industrial switch.
2. To remove the DIN-rail clip, reverse step 1.

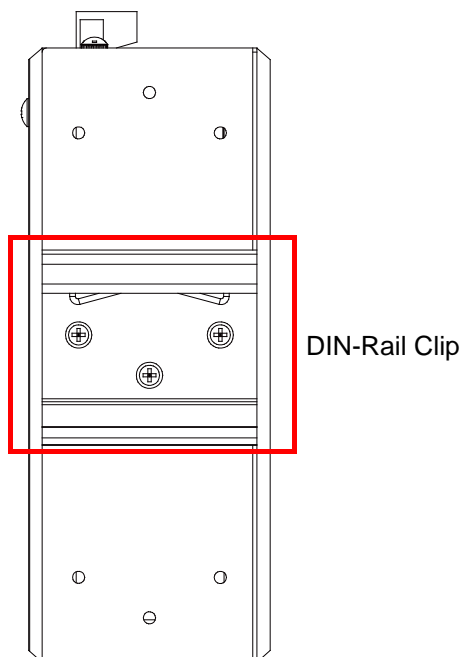
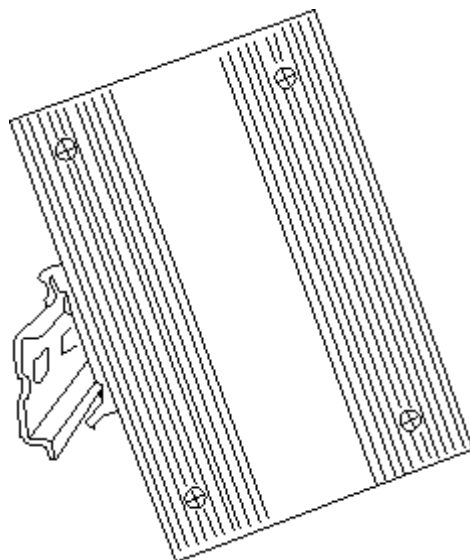

Figure 3.1 Rear side of the Switch

3.1.2 Hanging the Industrial Switch

Follow the steps below to hang the industrial switch on the DIN rail.

1. First, position the rear side of the switch directly in front of the DIN rail. Make sure the top of the clip hooks over the top of the DIN rail.



2. Push the unit downward.

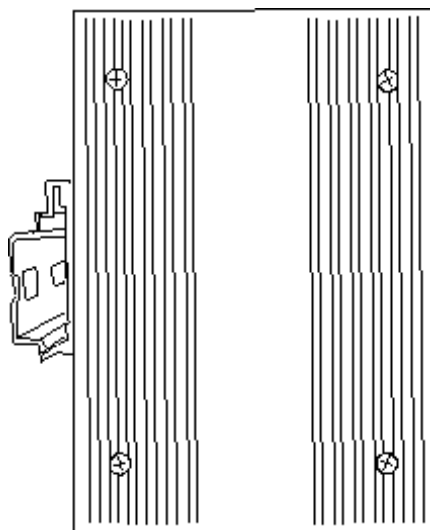

3. Check the DIN-Rail clip is tightly fixed on the DIN rail.
4. To remove the industrial switch from the track, reverse the steps above.

3.2 Wall Mounting

To hang the Ethernet switch on the wall, please follow the steps below.

1. Remove the DIN-rail clip.
2. Prepare the two wall-mount plates and six screws included.
3. Align the screw holes between the wall-mount plates and the unit as the figure illustrated.
4. Secure the plates to the unit with the accompanying screws.

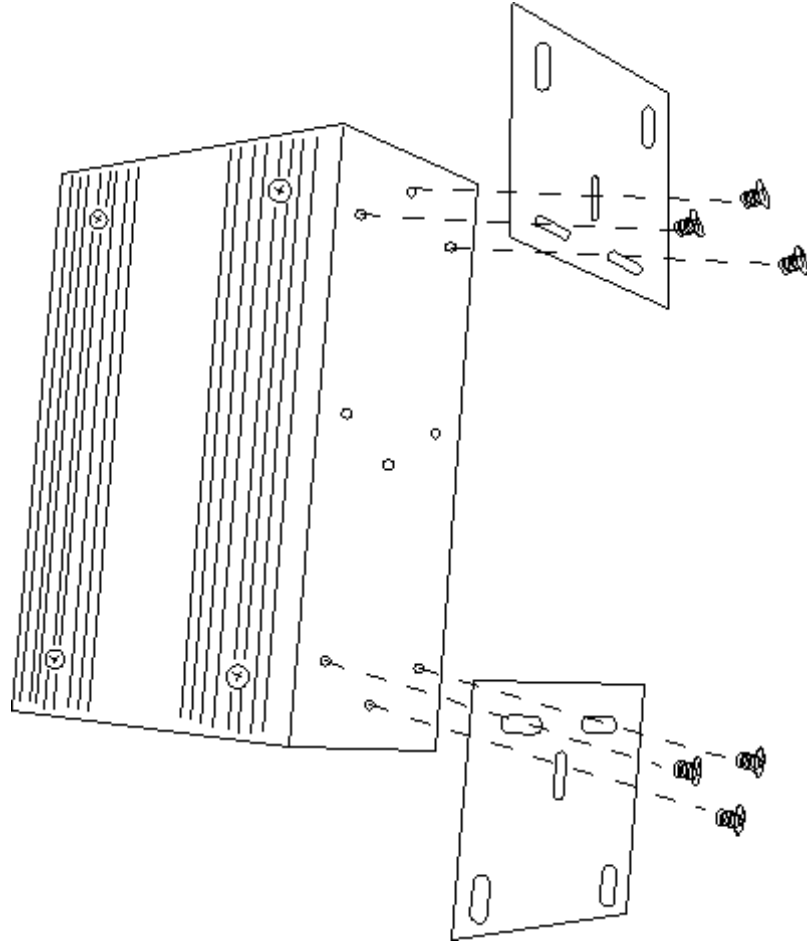

3.3 Grounding the Industrial Switch

Follow the instructions below to attach the industrial switch to ground.

Caution! When installing the industrial switch, the ground connection must always be made first and disconnected last.



1. On the top of the industrial switch, locate and remove the dome screw which has a ground symbol beside it.
2. Attach the ground wire to the screw hole with the dome screw.

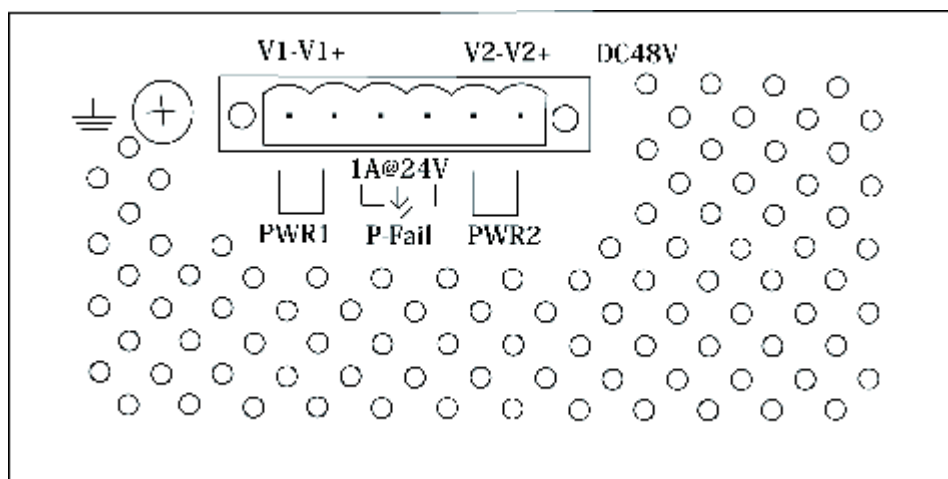

3.4 Wiring the Power Inputs

Please follow the steps below to wire power lines from the terminal block to the compliant external DC power source.

1. Before wiring, make sure the power source is disconnected.
2. Using the wire-stripping tool, strip a short piece of insulation from the output wires of the DC power source.
3. Identify the positive and negative feed positions for the terminal block connection. See the symbols printed on the panel indicating the polarities and DC input power range in voltage.

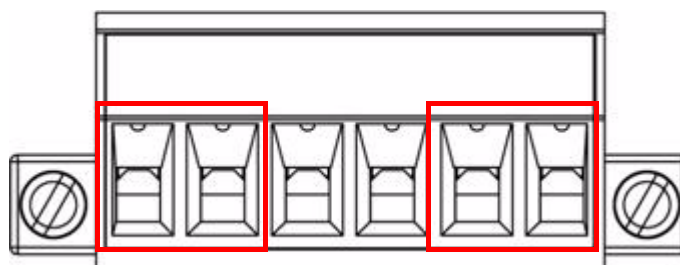

Figure 3.2 Plugs for Power 1 & Power 2

4. Insert the exposed wires into the terminal block plugs. Only wires with insulation should extend from the terminal block plugs. Note that the polarities between the wires and the terminal block plugs must be positive to positive and negative to negative.

5. Use a slotted screwdriver to tighten the captive screws.

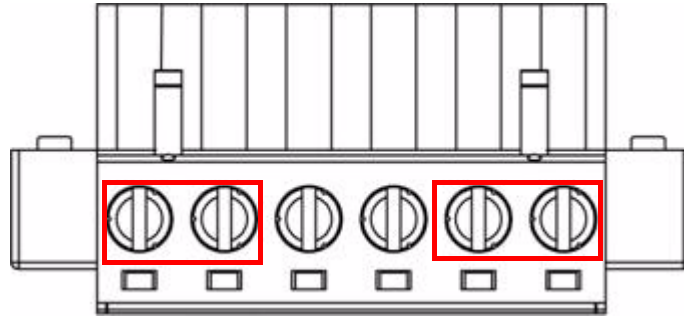

Figure 3.3 Captive Screws for Fixing Wires

- Caution!**
- Use Copper Conductors Only, 60/75 C, tightening to 5 lb-in
 - The wire gauge for the terminal block should be in the range between 12~ 18 AWG.



3.5 Wiring the Fault Alarm Contacts

The fault alarm plugs are in the middle of the terminal block, as the left picture shown below. With a Normally Close circuit formed by wiring with an external power and a warning device (a buzzer or a flashing LED), system will detect the fault status including the port linking failure (managed industrial switch only) and the power failure. Please refer to the right picture below, a wiring example for the fault alarm application.

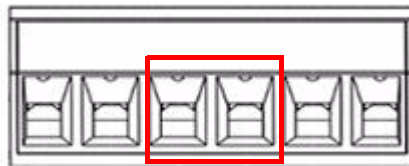

Figure 3.4 Terminal Block Plugs for Fault Alarm Contacts

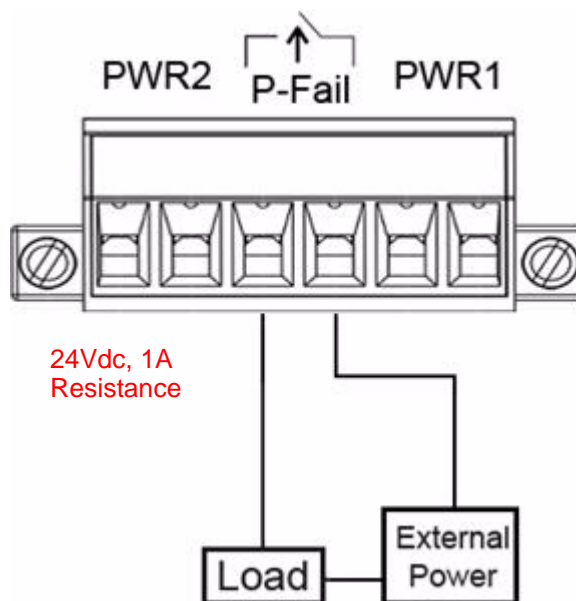

Figure 3.5 Fault Alarm Wiring Example

3.6 Ethernet Cabling

Use the four twisted-pair, Category 5e or above cabling for RJ-45 port connection. The cable between the switch and the link partner (switch, hub, workstation, etc.) must be less than 100 meters (328 ft.) long.

The small form-factor pluggable (SFP) is a compact optical transceiver used in optical communications for both telecommunication and data communication.

3.6.1 Connecting the SFP Port

To connect the transceiver and LC cable, please take the steps shown as follows:

First, insert the transceiver into the SFP slot. Notice that the triangle mark indicates the bottom of the slot.

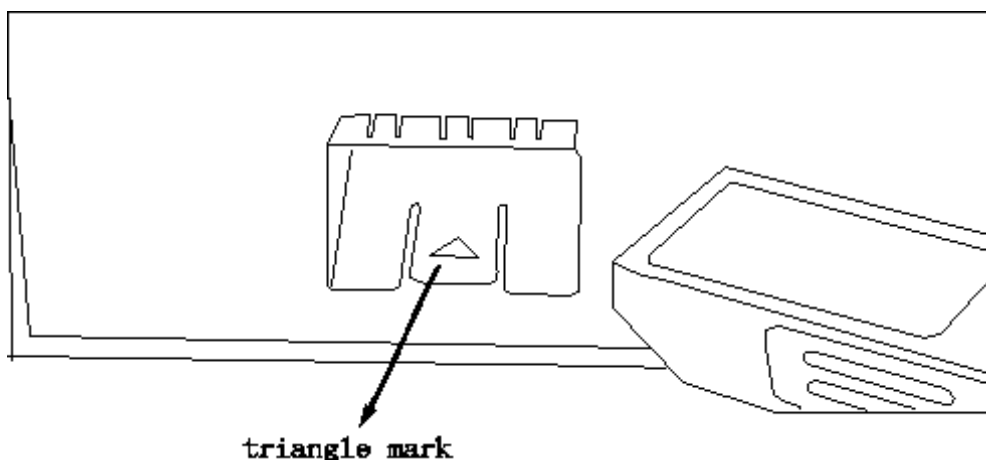

Figure 3.6 Transceiver to the SFP slot

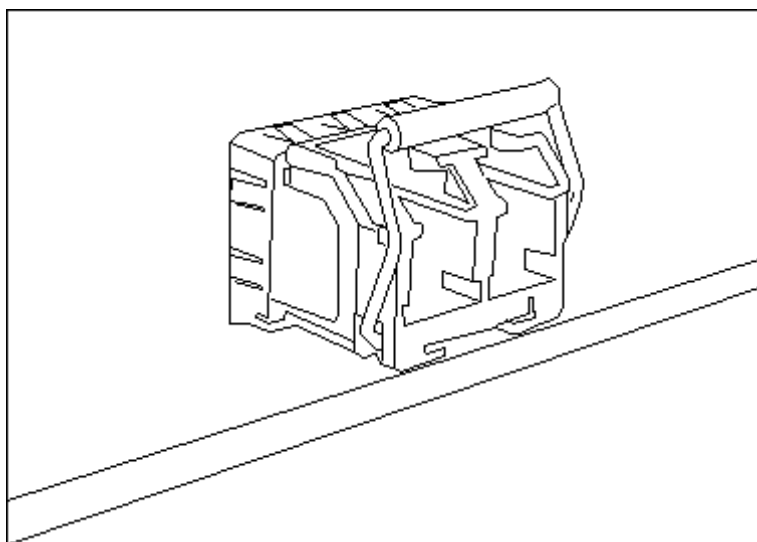

Figure 3.7 Transceiver Inserted

Second, insert the fiber cable of LC connector into the transceiver.

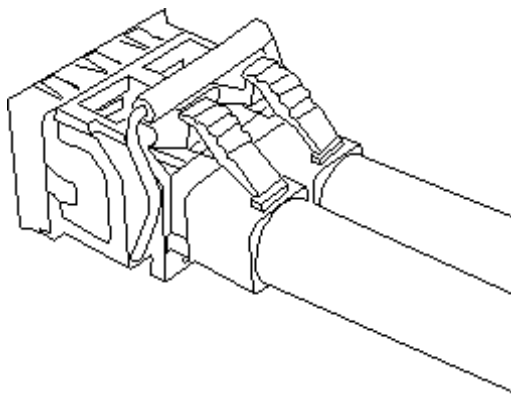

Figure 3.8 LC connected to the transceiver

3.6.2 Disconnecting the SFP Port

To remove the LC connector from the transceiver, please follow the steps shown below:

First, press the upper side of the LC connector from the transceiver and pull it out to release.

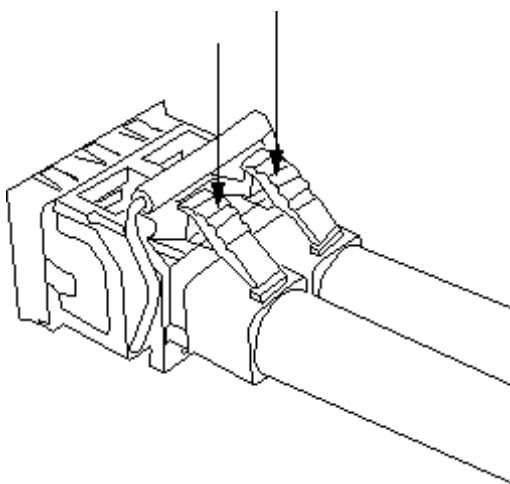

Figure 3.9 Remove LC connector

Second, push down the metal loop and pull the transceiver out by the plastic part.

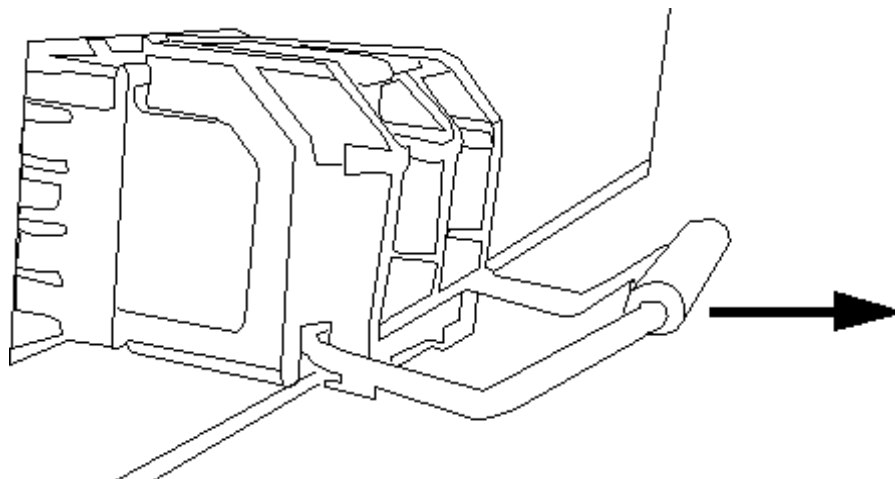

Figure 3.10 Pull out from the SFP slot

Appendix **A**

Troubleshooting

A.1 Troubleshooting

- Verify that you are using the included or appropriate power cord/supplier/adapter. Please don't use the power supplier/adapter with a non-compliant DC output voltage, or it will burn the equipment.
- Select the proper UTP/STP cable to construct your network. Please check that you are using the right cable. Use unshielded twisted-pair (UTP) or shield twisted-pair (STP) cable for RJ-45 connections: 100Ω Category 3, 4 or 5 cable for 10Mbps connections, 100 Category 5 cable for 100Mbps connections, or 100Ω Category 5e/above cable for 1000Mbps. Also be sure that the length of any twisted-pair connection does not exceed 100 meters (328 feet).
- Diagnosing LED Indicators: To assist in identifying problems, the Switch can be easily monitored through LED indicators on the front panel, which describe common problems the user may encounter and where the user can find possible solutions.
- If the power indicator does not light on when the power cord is plugged in, users may have a problem with the power cord. Then check for loose power connections, power losses or surges at power outlet. If you still cannot resolve the problem, contact the local dealer for assistance.
- If the Ethernet LED indicators are normal and the connected cables are correct but the packets still cannot transmit, please check your system's Ethernet devices' configuration or status.

Appendix **B**

Technical
Specifications

B.1 Technical Specifications

Standard	IEEE 802.3 10Base-T Ethernet IEEE 802.3u 100Base-TX Fast Ethernet IEEE 802.3ab 1000Base-T Gigabit Ethernet IEEE 802.3z 1000Base-X Gigabit Ethernet over Fiber-Optic IEEE802.3x Flow Control and Back Pressure IEEE802.3at Power over Ethernet
Protocol	CSMA/CD
Switch Architecture	Back-plane (Switching Fabric): 12Gbps Packet throughput ability (Full-Duplex): 17.85Mpps@64bytes
Transfer Rate	14,880 pps for Ethernet port 148,800 pps for Fast Ethernet port 1,488,000 pps for Gigabit Ethernet port
MAC Address	8K-entry MAC address table
Connector	10/100/1000Base-T: 4 x RJ-45 1000Base-X: 2 x SFP
PoE Pin Assignments	RJ-45 port #1 ~ # 4 support IEEE 802.3at End-point, Alternative A mode. Each port provides 30W@55V power carrying ability. Positive (VCC+): RJ-45 pin 1, 2. Negative (VCC-): RJ-45 pin 3, 6.
LED	Per unit: Power 1 (Green), Power 2 (Green), P-Fail (Red) Ethernet: Link/Activity (Green), Speed (Green), mini-GBIC: Link/Activity (Green), PoE (Green)
Network Cable	10Base-T: 2-pair UTP/STP Cat. 3, 4, 5, 5e, 6 cable EIA/TIA-568 100-ohm (100m) 100Base-TX: 2-pair UTP/STP Cat. 5, 5e, 6 cable EIA/TIA-568 100-ohm (100m) 1000Base-T: 2-pair UTP/STP Cat. 5E/6 or above cable EIA/TIA-568 100-ohm (100m)
Power Supply	DC 48V/2.5A, redundant power with polarity reverse protection (use DRP-240-48, the listed power supply, manufactured by the MEAN WELL Company)
Power Consumption	5.5W (Ethernet only)
Installation	DIN-Rail mounting, Wall mounting
Operating Temp.	-40 to 75°C (-40 to 167°F)
Operating Humidity	5% to 95% (Non-condensing)
Storage Temp.	-40 to 85°C
Dimensions	IP-30, 59.6mm (W) x 152mm (H) x 105mm (D)
EMC	FCC Class A CE EN61000-4-2/3/4/5/6/8 CE EN61000-6-2 CE EN61000-6-4
Safety	UL 508
Hazardous	UL/cUL Class I, Division 2, Groups A, B, C and D
Stability Testing	IEC60068-2-32 (Free fall) IEC60068-2-27 (Shock) IEC60068-2-6 (Vibration)

www.advantech.com

Please verify specifications before quoting. This guide is intended for reference purposes only.

All product specifications are subject to change without notice.

No part of this publication may be reproduced in any form or by any means, electronic, photocopying, recording or otherwise, without prior written permission of the publisher.

All brand and product names are trademarks or registered trademarks of their respective companies.

© Advantech Co., Ltd. 2012