

Wzzard™ Mesh Wireless Sensors

Intelligent Edge Nodes | Wireless Sensing Platform

USER MANUAL





Powered by

ADVANTECH

Advantech B+B SmartWorx - Americas

707 Dayton Road
Ottawa, IL 61350 USA
Phone (815) 433-5100
Fax (815) 433-5105

Advantech B+B SmartWorx - European Headquarters

Westlink Commercial Park
Oranmore, Co. Galway, Ireland
Phone +353 91-792444
Fax +353 91-792445

www.advantech-bb.com
support@advantech-bb.com

CONTENTS

WARRANTY.....	5
ABOUT THE WZZARD SENSING PLATFORM.....	6
Wireless Connectivity Where You Need It.....	6
Secure, Reliable, Highly Scalable Wireless Networking.....	6
Easy Configuration and Installation.....	6
Contents of Packages.....	7
Wzzard™ Industrial Node - model package includes:.....	7
Wzzard Commercial Node - model package includes:.....	7
HARDWARE INSTALLATION.....	8
Connecting Your Sensor to Wzzard Industrial Node Models.....	8
Conduit Node Models:.....	8
Industrial Node With M12 Connector & M12 Accessory Cable.....	9
Mounting The Node.....	10
Putting Node in Deep Sleep.....	11
Restoring Node to Factory Default.....	11
Battery Replacement.....	11
Connecting Your Sensor to Wzzard™ Commercial Node Model.....	13
MOUNTING Options – Commercial Node.....	13
Adhesive Strip Mounting.....	13
Mounting Bracket/Plate.....	14
Zip Tie Mounting.....	14
Putting Node in Deep Sleep.....	14
Restoring Node to Factory Default.....	14
CONFIGURING AND MANAGING WZZARD MESH WIRELESS SENSORS.....	15
CREATE AND LOCK THE NETWORK.....	16
CONFIGURE THE GATEWAY's MESH INTERFACE.....	18
NODE Configuration.....	20
EVENT DETECTION AND TRIGGER CONFIGURATION.....	21
ANALOG INPUT CONFIGURATION.....	24
DIGITAL INPUT CONFIGURATION.....	25
DIGITAL OUTPUT CONFIGURATION.....	26
TEMPERATURE INPUT CONFIGURATION.....	27
HUMIDITY INPUT CONFIGURATION.....	27
COPYING NODE CONFIGURATIONS.....	27
NETWORK DESIGN AND TROUBLESHOOTING.....	29
NETWORK PHYSICAL LAYOUT.....	29

GATEWAY/NETWORK LEVEL TROUBLESHOOTING	30
NODE LEVEL TROUBLESHOOTING.....	30
I/O TROUBLESHOOTING.....	32
SPECIFICATIONS FOR WZZARD MESH WIRELESS SENSORS	33
Industrial Node Models	33
Commercial Node Model	35
GENERAL SPECIFICATIONS – ALL MODELS – INDUSTRIAL & COMMERCIAL.....	36
RADIO SPECIFICATIONS – ALL MODELS – INDUSTRIAL & COMMERCIAL	37
MECHANICAL DRAWINGS.....	38
Wzzard Industrial Node Models	38
Wzzard Commercial Node Models	38
MODEL NUMBERS	39
Wzzard Mesh Wireless Sensors – Industrial Nodes.....	39
Wzzard Mesh Wireless Sensors – Commercial Nodes	39
DECLARATION OF COMPLIANCE.....	40
DECLARATION OF CONFORMITY - CE	42
ADVANTECH B+B SMARTWORX - TECHNICAL SUPPORT	44

WARRANTY

Advantech B+B SmartWorx warrants to the original end-user purchaser that this product, EXCLUSIVE OF SOFTWARE, shall be free from defects in materials and workmanship under normal and proper use in accordance with Advantech B+B SmartWorx' instructions and directions for a period of six (6) years after the original date of purchase. This warranty is subject to the limitations set forth below.

At its option, Advantech B+B SmartWorx will repair or replace, at no charge, the product which proves to be defective within such warranty period. This limited warranty shall not apply if the Advantech B+B SmartWorx product has been damaged by unreasonable use, accident, negligence, service or modification by anyone other than an authorized Advantech B+B SmartWorx Service Technician or by any other causes unrelated to defective materials or workmanship. Any replaced or repaired products or parts carry a ninety (90) day warranty or the remainder of the initial warranty period, whichever is longer.

To receive in-warranty service, the defective product must be received at Advantech B+B SmartWorx no later than the end of the warranty period. The product must be accompanied by proof of purchase, satisfactory to Advantech B+B SmartWorx, denoting product serial number and purchase date, a written description of the defect and a Return Merchandise Authorization (RMA) number issued by Advantech B+B SmartWorx. No products will be accepted by Advantech B+B SmartWorx that do not have an RMA number. For an RMA number, contact Advantech B+B SmartWorx at PHONE: (800) 624-1070 (in the U.S.A. and Canada) or (949) 465-3000 or FAX: (949) 465-3020. The end-user shall return the defective product to Advantech B+B SmartWorx, freight, customs and handling charges prepaid. End-user agrees to accept all liability for loss of or damages to the returned product during shipment. Advantech B+B SmartWorx shall repair or replace the returned product, at its option, and return the repaired or new product to the end-user, freight prepaid, via method to be determined by Advantech B+B SmartWorx. Advantech B+B SmartWorx shall not be liable for any costs of procurement of substitute goods, loss of profits, or any incidental, consequential, and/or special damages of any kind resulting from a breach of any applicable express or implied warranty, breach of any obligation arising from breach of warranty, or otherwise with respect to the manufacture and sale of any Advantech B+B SmartWorx product, whether or not Advantech B+B SmartWorx has been advised of the possibility of such loss or damage.

EXCEPT FOR THE EXPRESS WARRANTY SET FORTH ABOVE, ADVANTECH B+B SMARTWORX MAKES NO OTHER WARRANTIES, WHETHER EXPRESS OR IMPLIED, WITH RESPECT TO THIS ADVANTECH B+B SMARTWORX PRODUCT, INCLUDING WITHOUT LIMITATION ANY SOFTWARE ASSOCIATED OR INCLUDED. ADVANTECH B+B SMARTWORX SHALL DISREGARD AND NOT BE BOUND BY ANY REPRESENTATIONS OR WARRANTIES MADE BY ANY OTHER PERSON, INCLUDING EMPLOYEES, DISTRIBUTORS, RESELLERS OR DEALERS OF ADVANTECH B+B SMARTWORX, WHICH ARE INCONSISTENT WITH THE WARRANTY SET FORTH ABOVE. ALL IMPLIED WARRANTIES INCLUDING THOSE OF MERCHANTABILITY AND FITNESS FOR A PARTICULAR PURPOSE ARE HEREBY LIMITED TO THE DURATION OF THE EXPRESS WARRANTY STATED ABOVE.

Every reasonable effort has been made to ensure that Advantech B+B SmartWorx product manuals and promotional materials accurately describe Advantech B+B SmartWorx product specifications and capabilities at the time of publication. However, because of ongoing improvements and updating of Advantech B+B SmartWorx products, Advantech B+B SmartWorx cannot guarantee the accuracy of printed materials after the date of publication and disclaims liability for changes, errors or omissions.

ABOUT THE WZZARD SENSING PLATFORM

WIRELESS CONNECTIVITY WHERE YOU NEED IT

The Wzzard™ Mesh intelligent wireless sensor platform makes it quick and easy to connect sensors and communicate their data to your application, on your network or on the Internet, for visualization, analytics or integration into business applications.

The Wzzard Mesh platform connects to a vast range of industry-standard sensors. It uses Wzzard Mesh Wireless Sensor nodes and a wireless SmartMesh IP network to transmit intelligent sensor data to the SmartSwarm 342 Ethernet Gateway. The gateway can connect to the Internet via wired connections or the cellular data network.

Wzzard Mesh Wireless Sensors accommodate external sensors with a wide variety of sensor interface options, including general purpose analog inputs, digital input/output, thermocouples and 10K thermistors. They can also contain internal sensors like temperature and relative humidity.

SECURE, RELIABLE, HIGHLY SCALABLE WIRELESS NETWORKING

The Wzzard platform uses 802.15.4e wireless SmartMesh IP networking technology to deliver reliable, resilient and scalable communication with advanced network management and comprehensive security features. The platform uses full SmartMesh IP networking and time-synchronized channel hopping to provide up to 99.999% connectivity, even in the most demanding RF environments.

The Wzzard Mesh wireless sensor platform enables rapid network deployment and expansion. New nodes may be added at any time and the SmartMesh network dynamically self-configures as new nodes are added or removed. This process is a function of the mesh network itself and does not need to be controlled by the network gateway.

EASY CONFIGURATION AND INSTALLATION

Configuration of the Wzzard sensor platform is easy. The nodes can be configured with calibration and scaling information, engineering units, friendly names, and other descriptive information. The MQTT-JSON protocol is used to transport sensor data from the network gateway to any MQTT broker. MQTT-JSON is a highly efficient publish/subscribe protocol optimized for sending sensor data over wireless networks.

The platform simplifies physical installation as well. Wzzard Mesh Wireless Sensors can be attached to any surface using screws and flange mounting ears. The IP67 rated, fiber reinforced polyester PBT housing and the ability to connect to external sensors via conduit fitting or M12 connector make the units deployable in virtually any industrial or commercial environment.

CONTENTS OF PACKAGES

WZZARD™ INDUSTRIAL NODE - MODEL PACKAGE INCLUDES:

- Wzzard Mesh Wireless Sensor node – for industrial applications
- Sensor wire harness cable - conduit connection model only
- (2) AA 3.6V Thionyl Chloride Lithium batteries
- External antenna
- Quick Start Guide
- Anti-Skid disk

WZZARD COMMERCIAL NODE - MODEL PACKAGE INCLUDES:

- Wzzard Mesh Wireless Sensor Node – for commercial applications
- (1) 2/3 AA 3.6V Thionyl Chloride Lithium battery
- Quick Start Guide
- Mounting Bracket/Plate (included, factory installed)
- Dual adhesive strip (included, factory installed)



HARDWARE INSTALLATION**CONNECTING YOUR SENSOR TO WZZARD INDUSTRIAL NODE MODELS**

TIP: It is best practice that wiring is done prior to waking up the device.

Note: UL C1/D2 rating is voided when using non UL-specified batteries.

Remove the four (4) black screws that hold the top of the Wzzard node in place.

Connect your sensor.

CONDUIT NODE MODELS:

Thread the included wire harness through the conduit and into the node.

Plug the wire harness into the circuit board inside the node.

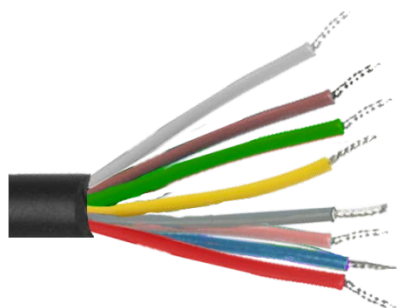

- 1 Brown
- 2 Red
- 3 Pink
- 4 Yellow
- 5 Green
- 6 Blue
- 7 White
- 8 Gray

Connect your sensor to the wires running from the node's conduit.

Consult the following chart for wire instructions:

WIRING FOR INDUSTRIAL NODE WITH CONDUIT CONNECTOR & ATTACHED WIRING HARNESS

	1 Brown	2 Red	3 Pink	4 Yellow	5 Green	6 Blue	7 White	8 Gray
WSD2C31010	10-30 VDC	AIN1	AIN2	AIN3	DIN1	GND	GND	GND
WSD2C21150	10-30 VDC	AIN1	AIN2	DO1	DIN1	GND	GND	GND

*** Wiring Chart Abbreviations:**
 10-30VDC = 10-30V DC Power Input
 AIN1 = Analog Input #1
 AIN2 = Analog Input #2
 AIN3 = Analog Input #3
 DIN1 = Digital Input #1
 DO1 = Digital Output #1
 GND = Ground Input

INDUSTRIAL NODE WITH M12 CONNECTOR & M12 ACCESSORY CABLE

Note: UL Class1/Division2 rating is voided when using M12 model

M12 WIRING

TIP: You can use your own M12 cable or order B+B SmartWorx M12 cable Model# BB-WSCAM12-6.

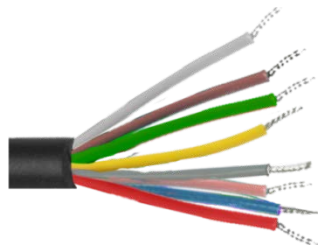
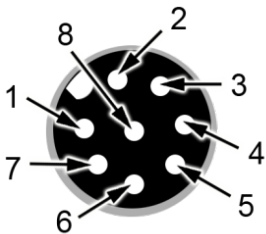

- 1 White
- 2 Brown
- 3 Green
- 4 Yellow
- 5 Gray
- 6 Pink
- 7 Blue
- 8 Red

Consult the following chart for M12 wiring instructions.

	1 White	2 Brown	3 Green	4 Yellow	5 Gray	6 Pink	7 Blue	8 Red
WSD2M31010	10-30 VDC	AIN1	AIN2	AIN3	DIN1	GND	GND	GND
<p>* Wiring Chart Abbreviations: 10-30VDC = 10-30V DC Power Input AIN1 = Analog Input #1 AIN2 = Analog Input #2 AIN3 = Analog Input #3 DIN1 = Digital Input #1 GND = Ground Input</p>								

TERMINAL BLOCK CONNECTIONS – THERMOCOUPLE & THERMISTOR

Thread the thermocouple and thermistor wires through the conduit and attach them to the terminal block.

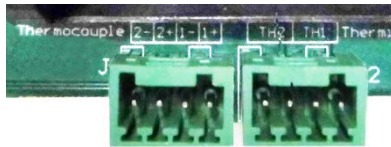

MOUNTING THE NODE

Wzzard industrial nodes may be mounted either with screws or temporarily with built-in magnets. The included anti-skid disk may be attached to bottom of unit to prevent slipping on metal surfaces.

Flange Mounting - Wzzard nodes may be mounted via their mounting ears. (M5, #10)



Temporary Magnetic Mounting* - Wzzard nodes include an internal mounting magnet embedded in the node's base – pull force 2.13 kg (4.7 lb) – convenient for temporary positioning and configuration.



*Notes:

- UL C1/D2 rating is voided if magnetic mounting is used for permanent application installation.
- Flange mounting only is recommended. Magnetic mounting is not an appropriate means of mounting.

PUTTING NODE IN DEEP SLEEP

When not using the node for some time, the node should be put into deep sleep.

Press the Status/Sleep/Reset configuration button for 5 seconds until the Status LED turns off.

The node will retain all settings, including the associated network if the node has been claimed. It will not reset the device back to factory settings.

RESTORING NODE TO FACTORY DEFAULT

To reset the node to factory defaults, press and hold the Status/Sleep/Reset configuration button for 10 seconds until the Status LED flashes quickly. This will:

- 1) Clear the sensor type information.
- 2) Clear the associated network information if the node has been claimed.
- 3) Allow the node to search for a new network.

BATTERY REPLACEMENT

Note: UL C1/D2 rating is voided when using non UL-specified batteries. Do not mix old and new batteries.

Remove the 4 black screws that hold the top of the node in place.

Install (2) 3.6 V AA Lithium Thionyl Chloride Batteries.



In most installations you will only need to place the batteries in the battery holder. But, in high vibration environments, you should also use the included black battery retaining clip.

Do not use excessive force while placing or removing the clip, as you can break it. The best way to remove the clip is to insert a small flathead screwdriver between the batteries and the clip (parallel to the batteries) and give the screwdriver a gentle twist. This will remove the clip without damage.

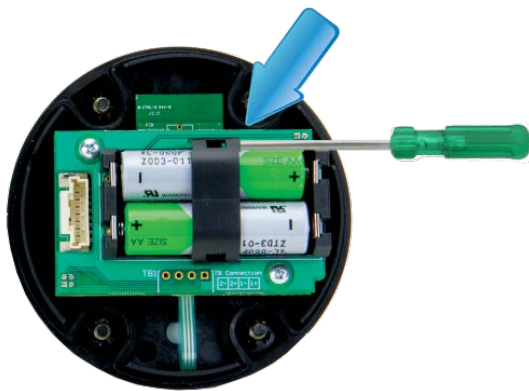

Note: As with all batteries, these are a fire, explosion, and severe burn hazard. Do not burn or expose them to high temperatures. Do not recharge, crush, disassemble, or expose the contents to water. Properly dispose of used batteries according to local regulations by taking it to a hazardous waste collection site, an e-waste disposal center, or other facility qualified to accept lithium batteries.

CONNECTING YOUR SENSOR TO WZZARD™ COMMERCIAL NODE MODEL

MOLEX CONNECTOR PORT

Connect your sensor's cable to the Wzzard Mesh Wireless Sensor node via the Molex connector port.



Mating Connector:

- _ Housing = Molex 51382-0600
- _ Terminal socket for housing = Molex 56134-9100

Consult the following chart for Molex pin-outs:

Molex Connector Pin-Out					
Pin 1	Pin 2	Pin 3	Pin 4	Pin 5	Pin 6
(Do Not Use)	DIN1	Thermistor Input	AIN1	AIN2	Common GND
<p>* Pin Abbreviations: DIN1 = Digital Input AIN1 = Analog Input AIN2 = Analog Input GND = Ground</p>					

THERMISTOR / BREAKOUT CABLE PIN-OUT

PIN#	AIN1		AIN2		Door Switch	
	Red	Black	Yellow	Black	Blue	Black
	AIN1	GND	AIN2	GND	DIN1	GND
<p>* Pin Abbreviations: AIN1 = Analog Input AIN2 = Analog Input DIN1 = Digital Input GND = Ground</p>						

MOUNTING OPTIONS – COMMERCIAL NODE

ADHESIVE STRIP MOUNTING

The Wzzard Mesh Wireless Sensor node can be mounted almost anywhere using the convenient 3M™ VHB (“Very High Bond”) adhesive mounting strip pre-attached to the back of the unit at the factory.



MOUNTING BRACKET/PLATE

The node enclosure includes an installed mounting bracket on the back. Simply remove the bracket to access the two screw holes in the plate.



ZIP TIE MOUNTING

The node enclosure also features two grip channel areas for securing the node with standard Zip ties.



PUTTING NODE IN DEEP SLEEP

When not using the node for some time, the node should be put into deep sleep.

Press the Status/Sleep/Reset configuration button for 5 seconds until the Status LED turns off.

The node will retain all settings, including the associated network if the node has been claimed. It will not reset the device back to factory settings.

RESTORING NODE TO FACTORY DEFAULT

To reset the node to factory defaults, press and hold the Status/Sleep/Reset button for 10 seconds until the Status LED flashes quickly. This will:

- 1) Clear the sensor type information.
- 2) Clear the associated network information if the node has been claimed.
- 3) Allow the node to search for a new network.

CONFIGURING AND MANAGING WZZARD MESH WIRELESS SENSORS

Management and configuration of the network, gateway, nodes, and sensor inputs is all done remotely through SmartWorx Hub. <https://hub.bb-smartworx.com/>

Refer to the SmartSwarm manual for information on how to log in and claim your gateway.

The configuration of the Wzzard Mesh sensor network is done at 3 levels:

1) Gateway/Network Level

When the gateway is selected in the tree, you can turn node discovery on and off, claim and release nodes, and review the health status of the network.

2) Node Level

When a single node is selected in the tree, you can configure the measurement interval, set up any triggers, retrieve live data from the node, and review network health information about the node.

3) Sensor Level

Expand the tree to see individual sensor I/O by clicking on the triangle next to the node.

The screenshot shows a tree view of sensor nodes. The node '00170D0000310AA3' is selected and expanded, showing a list of sensors: ai1 (0 V), ai2 (0 V), di1 (True bool), humidity (55.49 %), temp1 (60.64 C), tempint (22.97 C), and vbatt (3.216 V). A red circle highlights the expand/collapse icon next to the node. To the right, the 'Sensor Configuration' panel shows 'Enabled' (ON), 'Measurement Type' (Voltage), and 'Measurement Unit' (V). Below it, the 'Data Enrichment' panel shows 'Name' (ai1) and 'Engineering Unit' (V). At the bottom, there are input fields for 'Measured Value (V/mA)' (X0, X1) and 'Engineering Unit Value' (Y0, Y1), along with a 'Clear Values' button.

When an individual sensor is selected, you can configure all parameters for that endpoint. Enable/Disable, change between a voltage input and 4-20mA current, change scaling reported to real Engineering units, change temperature reported between Centigrade and Fahrenheit, etc.

CREATE AND LOCK THE NETWORK

1) Wake Up The Node

Press and hold Status/Sleep/Reset configuration button for 5 seconds until the Status LED comes on and starts blinking.

2) Check LEDs

After you wake the node, the Status LED will begin to blink. This indicates that the node is attempting to establish a network connection. The Status LED will come on solid when a network connection is made.

Note: The Status LED goes off after 10 seconds to conserve battery life. To check status, use a short press of the Status/Sleep/Reset configuration button.

Status LED		
Data	Slow Blink (1 per second)	Attempting to establish connection with SmartMesh IP network.
	Fast Blink (10 per second)	Firmware Update in progress.
	ON (solid, steady)	Unit is connected to wireless network.

3) Review Network And Claim Nodes

Follow the SmartSwarm quick start guide to claim and configure the gateway. With the gateway connected to the Internet, click on the “Wzzard Mesh” button.

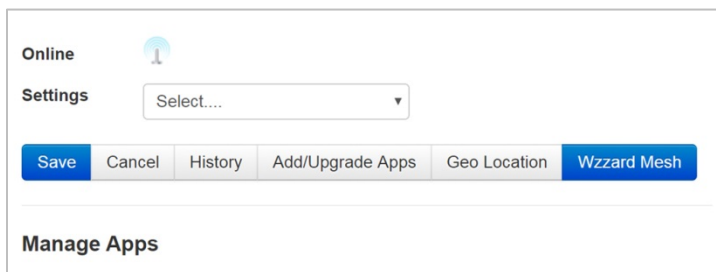

As nodes join the network, they will be added to the device tree under the gateway MAC address.

When all nodes' MAC addresses show in the tree, click the checkbox next to each node.

Click the “Claim Nodes” button to prevent the nodes from joining another open network.

All nodes will be set to a unique Network ID and Join Key for this network. They will no longer search for another open network

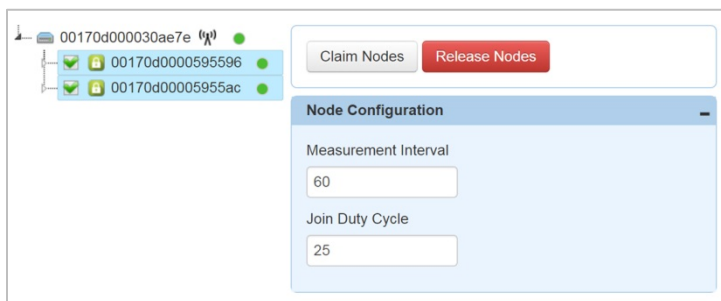

The gateway will automatically turn off node discovery for the network 24 hours after powering on. In some cases, it may be necessary to control this function manually.

- If it takes longer than 24 hours to get all nodes awake and the network to complete, you will need to turn node discovery back on until all nodes show in the tree.
- If it takes shorter than 24 hours to claim all of the desired nodes, you may want to manually turn off Node Discovery so that no other unclaimed nodes in the vicinity can join the network.

To manually control Node Discovery, select the gateway from the tree and click the Node Discovery switch to move it in the opposite position.

CONFIGURE THE GATEWAY'S MESH INTERFACE

Select your SmartSwarm Gateway by clicking on the Device ID.

Now, select the Wzzard Mesh App.

Manage Device

Dashboard > Devices > Manage Device

Device ID: 203-01-6500433

Name: 203-01-6500433

Status: Operational

Firmware: 2.2.2 [Push]

Device Type: BB-SG30000520-42

MAC Address: 00:0A:14:86:77:C6

Online: [Online]

Settings: Select...

[Save] [Cancel] [History] [Add/Upgrade Apps] [Geo Location] **Wzzard Mesh**

Manage Apps

Name	Tag	Type	Version	Help	Added
<input type="checkbox"/> RSMMessageBroker	RSMMessageBroker	Application	1.0.4		29/05/2018 14:33:48
<input checked="" type="checkbox"/> Wzzard Mesh	Wzzard Mesh	Application	1.0.8		29/05/2018 17:12:37
<input type="checkbox"/> NodeRED	NodeRED	Application	1.0.10		29/05/2018 14:33:48

To publish the Wzzard Mesh MQTT data to an MQTT you must configure the MQTT client in the SmartSwarm 342 for the broker you wish to publish. Enter the Broker's IP address in the Host field and enter the Broker's Port. If a User Name and Password are required for the broker, enter them here.

Client ID is a unique name made up by you and is required for any MQTT connection.

Timeout, Retry Interval, and Keep Alive need to be filled in to work with any broker. Defaults are shown below and should work in most instances.

The SmartSwarm 342 includes an internal broker for use with the embedded Node Red app. The internal broker is at the main IP address of the gateway. The default is 192.168.1.1. The port for the internal broker is 1883.

Settings [Help](#) [Log off](#)

Hello, knelson@advantech-bb.com

[Dashboard](#) [Devices](#) [Users](#) [Technology Providers](#) [Configuration Profiles](#) [Password](#) [Contact](#)

[Dashboard](#) > [Devices](#) > [Manage Device](#) > [Settings](#)

MQTT

Application Settings

Device ID: 203-01-6500433

Application Name: Wzzard Mesh

Version: 1.0.8

Tag:

* Required Field

MQTT

Host:

Port:

Username:

Password:

Client ID: *

Timeout (secs):

Retry Interval (secs):

Keep Alive (secs):

Reliability:

Clean Session:

If you wish to have a secure TLS connection to the MQTT server, enable TLS and upload the required certificates and private key.

MQTT

Enable TLS:	<input type="text" value="Yes"/>
Verify Server Cert:	<input checked="" type="checkbox"/>
Mutual Authentication:	<input checked="" type="checkbox"/>
Server Root CA Cert -	
Load File	
<input type="text"/>	
Client Certificate -	
Load File	
<input type="text"/>	
Client Private Key -	
Load File	
<input type="text"/>	
Passphrase:	<input type="text"/>
Last Will & Testament +	

Apply your changes.

NODE CONFIGURATION

Each node can be set to read and publish its sensor data at a fixed Measurement Interval. The Measurement Interval should be set as large as possible to save battery life and still get the measurement resolution required by the application. The nodes are capable of a Measurement Interval of 10s to 84,600s (24 hours). The default is set to one minute.

To set the Measurement Interval for a node:

- Select the node from the tree.
- Expand the Node Configuration section by clicking on the “+” sign.
- Enter the desired Measurement Interval in seconds

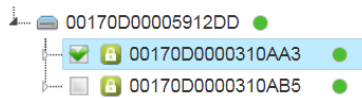

Node

Node Info +

Node Configuration -

Measurement Interval (s)

Event Detection and Triggering +

Once you click off of the Measurement interval field, a banner will ask if you want to review and save changes.

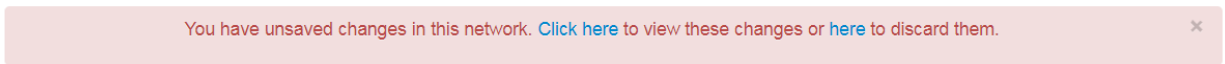

Click to view the changes. Any changes you've made will be summarized in the tree. Apply Changes or Discard Changes after you review.

[Dashboard](#) > [Devices](#) > [Manage Device](#) > Wzzard Mesh Confirmation

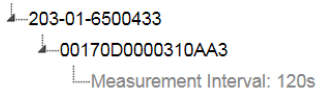

EVENT DETECTION AND TRIGGER CONFIGURATION

To save on communications between the gateway and external devices, each node can be configured to only send its data out of the gateway at specific time periods or when limits of an input are exceeded. This is especially helpful in conserving data costs on a cellular network.

On Time:

Turning on On-Time publishes allows you to publish data values to MQTT over a longer time interval than what's being measured at the node.

On Value:

If On Time is turned on, the On Value setting allows you to override the On-Time setting if an analog, temperature, or humidity exceeds or falls below a settable threshold. In addition, turning on Fast Mode increases the measurement frequency until the threshold Rule is no longer true.

Setting	Acceptable Values	Default Value	Description
On Time	Checked/ Not Checked	Not Checked	Turns on/off publishes from the node at a settable value independent of the Measurement Interval.
Publish	Minute Hour Day	Minute	Defines the publish interval of the node. The Measurement Interval set in Node Configuration is still polling the I/O.
On Value	Checked/ Not Checked	Not Checked	Turns on/off publishes from the node when a trigger Rule has been met.
Fast Mode	On/Off	Off	With Fast Mode On, when a trigger Rule has been met, the Measurement Interval and Publish Interval for the node is set to the value set in the Measurement Interval field. It will stay set to this interval until the trigger Rules are no longer true or until the time specified in the Duration field.
Measurement Interval	10s to 84,600s (24 hours)	None	In the Measurement Interval field, specify the temporary Measurement Interval to be used while a trigger Rule is met.
Duration	10s to 84,600s (24 hours)	None	In the Duration field, specify how long you want the temporary Measurement Interval to be in effect.
Add Rule	Click	N/A	Click to add a trigger rule.

Trigger Rules:

- Select whether you want to start receiving data when an input exceeds a certain value or falls below a certain value.
- Select which input on the node to which you would like to apply the rule.
- Enter the Threshold value to be exceeded in order for the trigger Rule to be true. Values should be entered in Engineering Units
- Enter a value of hysteresis you would like to exceed before the trigger Rule is no longer true. Hysteresis values are entered as a percentage of the Threshold value.

Ex.: I have a refrigeration unit storing ice cream and I continuously monitor the temperature with a Wzzard Mesh sensor and a cellular gateway. To save on cellular data, I'd like to know the temperature only once a day unless it goes above my acceptable maximum temperature of +6 degrees Fahrenheit, in which case I want a report of temperature every minute for an hour or until my temperature is back in range.

- Have the temperature input node set to a 1 hour measurement interval and reporting in Degrees Fahrenheit.
- Click the On Time check box to enable On Time publishes.
- Set the Publish interval to publish the last sample every Day.
- Click the On Value check box to enable publishing when trigger Rules are true.
- Click to turn on Fast Mode.
- Set my temporary Measurement Interval to 60s (1 minute).
- Set my Duration to 3600s (1 hour).
- Add a rule that sets HI, Temp1 >= 6, 10% hysteresis.
- Click to review and save the changes.

You have unsaved changes in this network. [Click here](#) to view these changes or [here](#) to discard them.

- 00170D00005912DD ●
- 00170D000030EC0D ●
- 00170D0000310AA3 ●**
 - at: 2018-07-06 16:27:18Z
 - ai1 0 V
 - ai2 0 V
 - di1 True bool
 - humidity 55.2 %
 - temp1 97.21 C
 - tempint 22.56 C
 - vbatt 3.216 V
- 00170D0000310AB5 ●

Node

Update Data Replicate Settings Claim Node Release Node

Node Info +

Node Configuration -

Measurement Interval (s)

View History

Event Detection and Triggering -

On Time
Publish Last Sample Every

On Value
Fast Mode ON Measurement Interval Duration

Rules Add Rule

HI temp1 ≥ 6 10%

ANALOG INPUT CONFIGURATION

Analog inputs can be Enabled/Disabled. It's recommended that you disable all unused inputs to save on wireless traffic and battery life. Analog inputs are Enabled by default.

The analog input can be set to a 0-10V Voltage signal or to a 0-20mA Current signal. This will depend on the output of the sensor attached to the analog input. Analog inputs are set to Voltage by default.

The MQTT data coming from the Analog input can also be pre-scaled into real world Engineering units as it is published from the gateway. Any consumers of the data could avoid having to make their own transformations.

In the Data Enrichment section, enter the real world value being measured (% , Gallons, AC Amps, etc.). Then enter two data points that correlate the measured Voltage or Current to the real world Engineering unit being measured.

Ex.: I have a linear level sensor that outputs 4mA when a 500 gallon tank is empty and 20mA when the tank is full.

- Enable the analog input.
- Set the Measurement Type to Current.
- Change Engineering Unit to Gallons.
- Enter my first data pair (4, 0) for 4mA = 0 Gallons.
- Enter my second data pair (20, 500) for 20mA = 500 Gallons.
- Click to review and save the changes.

You have unsaved changes in this network. [Click here](#) to view these changes or [here](#) to discard them.

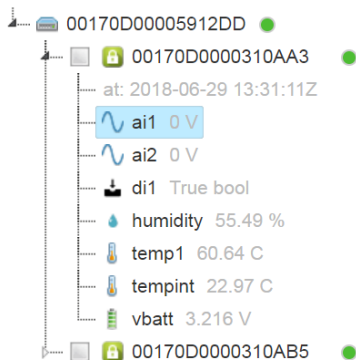

Sensor Configuration

Enabled

Measurement Type

Measurement Unit mA

Data Enrichment

Name ai1

Engineering Unit

Measured Value (V/mA)	Engineering Unit Value
<input type="text" value="4"/>	<input type="text" value="0"/>
<input type="text" value="20"/>	<input type="text" value="500"/>

DIGITAL INPUT CONFIGURATION

Setting	Acceptable Values	Default Value	Description
Enabled	On/Off	On	Digital inputs can be Enabled/Disabled. It's recommended that you disable all unused inputs to save on wireless traffic and battery life.
Inverter	On/Off	Off	Defines if 1= High input or 1 = Low input Inverter Off, 1=High and 0=Low Inverter On, 1=Low and 0=High
Measurement Type	Boolean	Boolean	A Boolean Measurement Type will publish a 1 or 0 at the Measurement Interval when the node reads the value.
	Event		An Event Measurement Type will publish the value 1 when the input changes to 1 regardless of the node's Measurement Interval
	Counter		A Counter Measurement Type will publish the number of 0 to 1 transitions received on the Digital Input at the node's Measurement Interval.
	Rate		A Rate Measurement Type will publish 1/the number of 0 to 1 transitions received on the Digital Input during a one second sample at the node's Measurement interval (Hz)
Multiplier	Number above 0.000001		The Multiplier is the number a Counter or Rate will be multiplied by before being published over MQTT.
Engineering Unit	ASCII Text String	bool	Defines the unit that is published over MQTT with the data (On/Off, Hz, RPM, Count, Etc.)

Ex: I have a shaft that is supposed to constantly rotate at 1,000 RPM. I want to know the rotation speed. It has an active low proximity switch mounted with two magnets on either side of the shaft.

- I would Enable the digital input.
- I would set the Measurement Type to Rate.
- I would set my Multiplier to 30 (RPM = Rate/2 magnets per rotation x 60 seconds/minute)
- I would change my Engineering Unit to RPM
- Click to review and save the changes

You have unsaved changes in this network. [Click here](#) to view these changes or [here](#) to discard them.

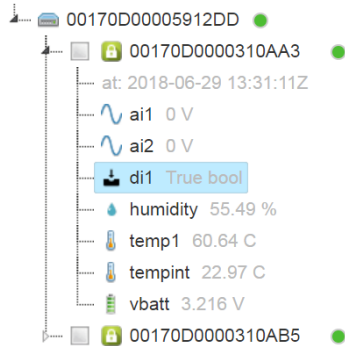

Sensor Configuration

Enabled

Multiplier

Measurement Type

Measurement Unit

Data Enrichment

Name

Engineering Unit

DIGITAL OUTPUT CONFIGURATION

Digital outputs can be Enabled/Disabled. It's recommended that you disable all unused I/O to save on wireless traffic and battery life. Digital outputs are Enabled by default.

The Inverter Switch defines if 1= High output or 1 = Low output

Inverter Off, 1=High and 0=Low

Inverter On, 1=Low and 0=High

The Digital Output Mode switch allows you to manually set the Digital Output Off or On. The output setting will be overridden by any MQTT command to set the output.

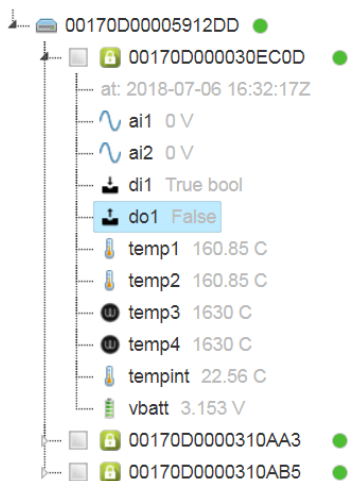

Sensor Configuration

Enabled

Inverter

Digital Output Mode

Data Enrichment

Name

TEMPERATURE INPUT CONFIGURATION

Temperature inputs can be Enabled/Disabled. It's recommended that you disable all unused inputs to save on wireless traffic and battery life. Temperature inputs are Enabled by default.

Temperature MQTT publishes can be set to either Celsius or Fahrenheit. Temperature readings are set to Celsius by default.

Click to review and save any changes.

You have unsaved changes in this network. [Click here](#) to view these changes or [here](#) to discard them. ✕

HUMIDITY INPUT CONFIGURATION

Humidity inputs can be Enabled/Disabled. It's recommended that you disable all unused inputs to save on wireless traffic and battery life. Humidity inputs are Enabled by default.

COPYING NODE CONFIGURATIONS

If more than one node is used to monitor the same type of asset, it is simpler to copy configurations between nodes than to set up each node individually. Once a node and all its I/O have been configured, you can copy that configuration to any other nodes of the same model.

1. In the tree, select the configured node you wish to copy and click the Replicate Settings button.

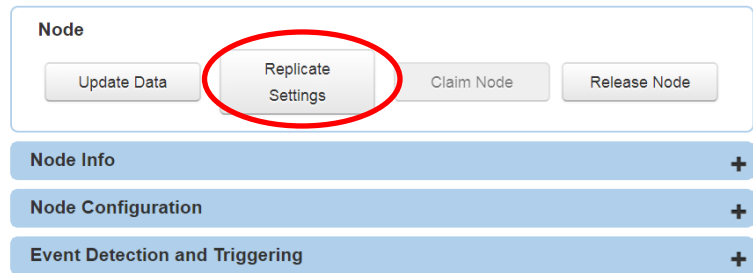
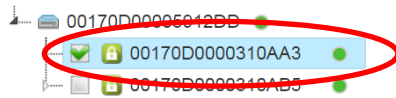

2. The screen will provide a list of all nodes on the network with the same model number. Select the MAC address of the node(s) you wish to copy to and click the Replicate Settings button. All settings for the node and the I/O points will be copied to the selected node(s).

Replicate Node 00170D0000310AA3

Please select which nodes these settings will be replicated to:

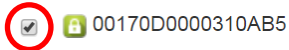

Close Replicate Settings

NETWORK DESIGN AND TROUBLESHOOTING

NETWORK PHYSICAL LAYOUT

The Wzzard Mesh network is extremely robust and reliable when you follow a few simple rules.

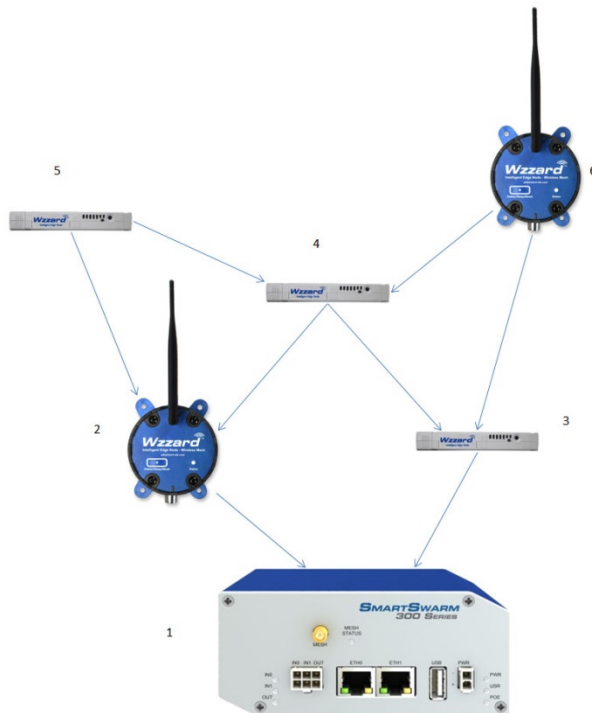

1. Each node should have a line of site path to 3 other nodes or to the gateway. 2 of these should be in the direction closer to the gateway if possible. In the small example network above, only nodes 5 and 6 violate this rule. The outermost nodes may not have a third node to connect to, but they do have 2 good "Parents" in their path back to the gateway.
2. You should be able to picture at least two paths from any one node to the gateway.
3. Each path should be as short as possible. Less than 100m indoors with lots of metal or walls. Less than 300m outdoors with no obstructions.
4. No node's data should have to go through more than 7 other nodes before reaching the gateway. 8 hops is the maximum allowed by the network.
5. It's best to build the network from the gateway out where possible. The more nodes that attach directly to the gateway, the less traffic that has to flow through a single node. The small example network above has two nodes that connect directly to the gateway. For larger networks, this number should be higher.

No RF site survey is necessary. The SmartMesh IP network will automatically adjust frequencies between channels when RF conditions change.

As nodes are added to the network, they will automatically join the network and the paths will be re-optimized for reliable communication

SmartWorx Hub provides several features for troubleshooting your Wzzard Mesh network, individual nodes, and individual I/O points.

GATEWAY/NETWORK LEVEL TROUBLESHOOTING

A well-formed Mesh network should provide greater than 99.999% reliability in transmitting data from the nodes to the gateway. The Network Reliability indicator gives a quick way to review that your network is performing up to this standard.

Green The network is sending at least 99.9% of its attempted packets to the gateway successfully.

Yellow The network is sending at least 99.0% of its attempted packets to the gateway successfully.

Red The network is sending less than 99.0% of its attempted packets to the gateway successfully.

If the Network Health Color is not staying green 30 minutes after full network formation, review the nodes and their respective health color.

NODE LEVEL TROUBLESHOOTING

There are two indications in SmartWorx Hub that a node is not behaving properly in the Mesh network.

- 1) A node reports as lost (Line through the node in the tree)
- 2) Health color is yellow or red.

If a Node Health Color is not staying green 30 minutes after full network formation, or if a node is periodically lost:

1. With the node selected in the tree, check the Number Good Parents in the Node Info section. This number should always be 2 for every node, except the one nearest the gateway.
2. Check the loaded battery voltage shown in the I/O portion of the selection tree for the node. If the data is old, select the node in the tree and click the Update Data button. The battery voltage should be above 2.8V. Anything lower and the battery is starting to become depleted and the node may not work reliably.

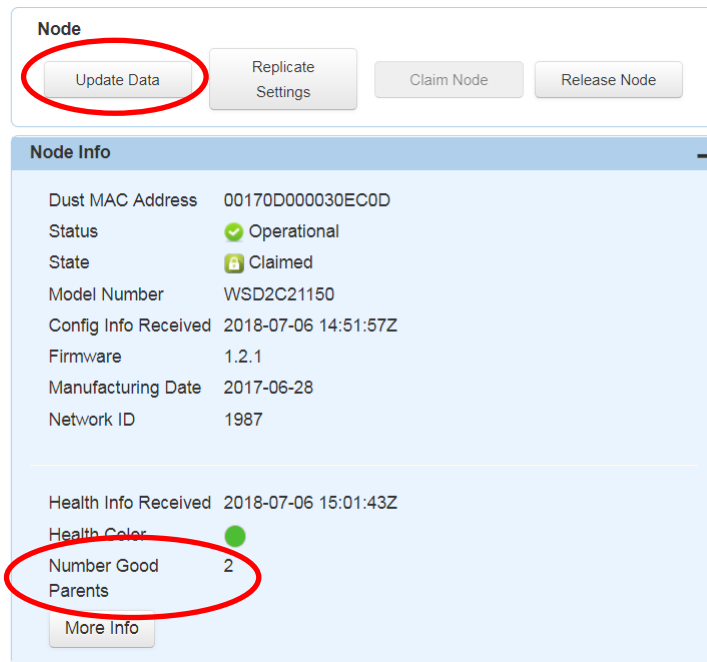
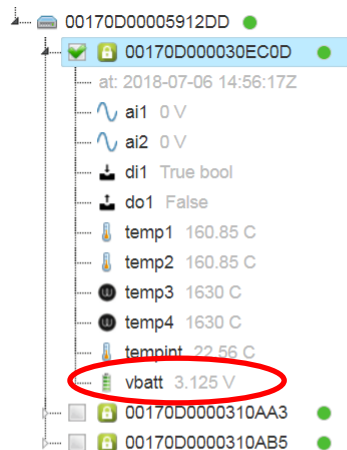

3. Check the node physically:

- Are there at least 2 nodes toward the gateway that you can see from the location of the trouble node? Can you move the node slightly to have it better line up with both of the other nodes? Nodes can also be added as repeaters. Since all nodes act as repeaters, just set one down and turn it on.
- Is this node at the same height as others in the vicinity? The farther from ground the node can be mounted, the more the RF signal has a place to expand.
- On industrial nodes, is the antenna parallel to other nodes in the vicinity? You may want to rotate the antenna if there is a vertical distance between this node and its neighbors.

I/O TROUBLESHOOTING

SmartWorx Hub allows the user to read inputs and turn on/off outputs to check the I/O connections and configuration.

1. Expand the tree to see the I/O points by clicking the triangle next to the node in the tree. Data is shown in the Engineering Units set in the I/O point configuration. The date and time of the last data read is shown at the top of the I/O point list. This time is in Zulu time (Usually GMT)
2. To get a new data reading, select the node and click the Update Data button. After a few seconds, the new sensor readings for that node will appear in the tree.

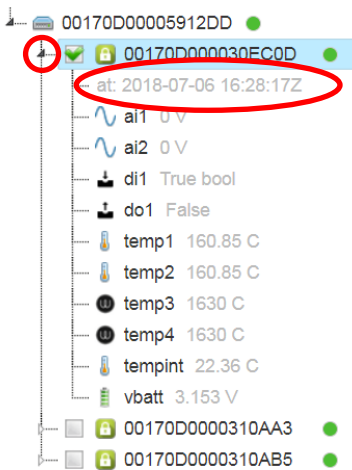

Node

Update Data Replicate Settings Claim Node Release Node

Node Info

Dust MAC Address	00170D000030EC0D
Status	Operational
State	Claimed
Model Number	WSD2C21150
Config Info Received	2018-07-06 16:27:22Z
Firmware	1.2.1
Manufacturing Date	2017-06-28
Network ID	1987

SPECIFICATIONS FOR WZZARD MESH WIRELESS SENSORS

INDUSTRIAL NODE MODELS



Power	
Power Source/s	(2) 3.6V Lithium AA Batteries. Optional external power.
External Input Voltage (opt.)	10-30 VDC @ 40mA (peak)
Connection Options	1/2" Conduit (UL Type 3 outdoor approved), 12.7mm (0.5in). Includes: sensor interface cable - 8 wire, 26 gauge, 1.8M (6 ft) (Models# BB-WSD2C31010, BB-WSD2C21150)
	M12 (Model# BB-WSD2M31010) (Not UL rated for outdoor applications.)
Battery Life	>5 years, based on 1 minute measurement interval
External Antenna (included)	RPSMA, omni-directional, 3.8 dBi, 2.4 GHz. Dimensions: 194mm (7.64in)
Environmental -- Intended for indoor and outdoor use.	
Operating Temperature	-40 to +80 °C (-40 to +176 °F)
Storage Temperature	-40 to +85 °C (-40 to +185 °F)
Operating Humidity	0 to 95% non-condensing
LED Indicator/s	
Data	Network Connectivity, Firmware Update
Enclosure Rating	
Rating/Material	IP67-rated, fiber reinforced polyester PBT
Mounting	(4) mounting ear flanges & screws
Certifications	
FCC	FCC Part 15 Class A, FCC - Part 15.247
IC	ICES-003:2016, ITE Emissions for Canada
CE	
2014/35/EU	Low Voltage Directive
2014/53/EU	Radio Equipment Directive
2011/65/EU	Reduction of Hazardous Substances Directive (RoHS)
2012/19/EU	Waste Electrical and Electronic Equipment Directive (WEEE)
ETSI EN 300 328 v2.1.1	EMC & Radio Spectrum Matters (ERM) Wideband Transmission Systems, 2.4 GHz ISM Band
ETSI EN 301 489-1 v2.1.1 ETSI EN 301 489-17 v3.2.0	Applied in Accordance with Specific Requirements of: EMC and Radio Spectrum Matters: Broadband Data Systems
EN 55032:+AC, Class A	Information Technology Equipment - RF Emissions
EN 55024	Information Technology Equipment - Immunity Characteristics - Limits and Methods of Measurement
ETSI EN 300 328 v2.1.1	EMC & Radio Spectrum Matters (ERM) Wideband Transmission Systems, 2.4 GHz ISM Band
EN/IEC 61010-1 (3rd Ed.)	Safety Requirements for Electrical Equipment for Measurement, Control, and Laboratory Use (general requirements)
EN/IEC 61010-2-201 (1st Ed.)	Particular Requirements for Control Equipment
EN 62479	Assessment of Compliance of Low Power Electronics and

	Electrical Equipment with Basic Restrictions - Related to Human Exposure to Electromagnetic Fields (10 MHz to 300 MHz)
UL (all models w/mounting ear installation; M12 model indoors only)	
UL/CSA Class 1/Division 2, Groups A, B, C, D	
Safety	
IEC 60068-2-6	Sine Vibration: 4G, 10-500 Hz, 0.06 in. displacement
IEC 60068-2-27	Mechanical Shock: 50G, 11ms, 18 pulses
Regulatory Approvals	
RoHS and WEEE Compliant	

THIONYL CHLORIDE LITHIUM BATTERY* - 2 supplied with industrial nodes	
Size	AA
Temperature Range	-55 to +85 °C
Nominal Capacity	2.4 Ah
Nominal Voltage	3.6 V
Diameter	14.5 mm
Height	50.1 mm
*Potential Hazard: Do not recharge, crush, disassemble or heat above 212 °F (100 °C)	

COMMERCIAL NODE MODEL



Power Supply	
Source, internal	(1) 3.6V 1650mAh 2/3 Lithium Thionyl Chloride Battery
Connectors	Analog Input: 0-10VDC, 0-20mA (software selectable) Digital Input: 0-48 VDC Digital Input Frequency: 1-1K Hz, Accuracy +/- 1Hz
Battery Life	>5 years, based on 1 minute sensor sampling and reporting interval
Connection	
Physical Connector	Molex 6-pin MicroClasp
Environmental (intended for indoor use)	
Operating Temperature	-20 to +70°C (-4 to 158°F)
Storage Temperature	-40 to 85°C (-40 to 187°F)
Operating Humidity	0 to 95% non-condensing
LED Indicator/s	
Data	Network Connectivity, Firmware Update
Enclosure Mounting	
Mounting	Mounting bracket (included), VHB adhesive strip (included), or ZIP ties (not included)
Weight	0.09kg (0.2 lb)
Certifications	
FCC	FCC Part 15 Class A, FCC Part 15.247
IC	Industry Canada - RSS210
Regulatory	RoHS and WEEE Compliant
CE	
EN 55022	CISPR Class B
EN 61000-6-2	Generic Immunity Standard for (Heavy) Industrial Environments
EN 61000-6-4 + A1	Emission Standard for (Heavy) Industrial Environments
EN 61000-4-2	ESD +/- 15kV air, +/- 4kV contact
EN 61000-4-3	RFI
EN 61000-4-4	EFT
EN 61000-4-5	Surge
EN 61000-4-6	CI
THIONYL CHLORIDE LITHIUM BATTERY* - 1 supplied with commercial node	
Size	2/3 AA
Temp. Range	-55 to +85 °C
Nominal Capacity	1.65 Ah
Nominal Voltage	3.6 V
Diameter	14.5 mm
Height	33.5 mm
Battery Life, est.	>5 years, based on 1 minute measurement interval
*Potential Hazard: Do not recharge, crush, disassemble or heat above 100 °C (212 °F)	

GENERAL SPECIFICATIONS – ALL MODELS – INDUSTRIAL & COMMERCIAL

Digital Inputs	
Voltage Range	0 – 48 VDC
V _{IL}	0.4V maximum
V _{IH}	2.5V minimum
Pull up Current	65 uA
Type	Sinking (NPN) Input
Isolation	None
Frequency	1-1KHz (Accuracy: +/- 1 Hz)
Digital Outputs	
Voltage Range	0-30 VDC
Output Type	Open Drain
Output Current	Not to be less than 100mA
Protection	Current Limit Protection
Isolation	None
Type	Sinking, up to 100mA @ 30VDC
Rate/Frequency Inputs	
Frequency	Performs 1 second measurement at each measurement/publish interval Uses falling edge or rising edge, based on Invert Enabled Setting
Input Counter	
Channels	Actively counts either falling edge (Invert Enabled) or rising edge (Invert Disabled) Can use a multiplier to convert to a unit type or count Shared with digital inputs Rolls over at 999999.9
Analog Inputs	
Input Range	0 - 10 VDC, 0 - 20 mA (software selectable)
Load Resistance	59 K Ohms
Accuracy	+/- 25mV, +/- -0.05mA
Resolution	0.3 mV / 1.3 uA
Thermocouple Input (Industrial Nodes Only)	
Types Supported	J, K, N, R, S, T, B, E
Temperature Range Supported	J = -210 to +1200 °C K = -200 to +1372 °C N = -200 to +1300 °C R = -50 to +1768 °C S = 50 to +1768 °C T = -200 to +400 °C B = +95 to +1798 °C E = -200 to +1000 °C
Resolution	0.0078 °C
Accuracy	0.20% of full-scale reading (0.25%, maximum)

RADIO SPECIFICATIONS – ALL MODELS – INDUSTRIAL & COMMERCIAL

SmartMesh IP 802.15.4e Radio Specifications					
Parameter	Conditions	Min.	Typical	Max.	Units
Frequency Band		2,400		2,4835	GHz
Number of Channels			15		
Channel Separation			5		MHz
Channel Clear Frequency			2405 + 5*(k-11)		MHz
Modulation	IEEE 802.15.4 Direct Sequence Spread Spectrum (DSSS)				
Raw Data Rate			250		kbps
Range	Indoor		100		m
	Outdoor		300		m
Receiver Sensitivity	Packet Data Error Rate (PER) = 1%			-93	dBm
	PER = 50%			-95	dBm
Conducted Output Power (PA On)	Delivered to a 50 Ω load		8		dBm
Conducted Output Power (PA Off)	Delivered to a 50 Ω load		0		dBm
Radiated Output Power (PA On)	Taoglas PA.11.BB antenna		7		dBm
Radiated Output Power (PA Off)	Taoglas PA.11.BB antenna		-1		dBm

MECHANICAL DRAWINGS

WZZARD INDUSTRIAL NODE MODELS

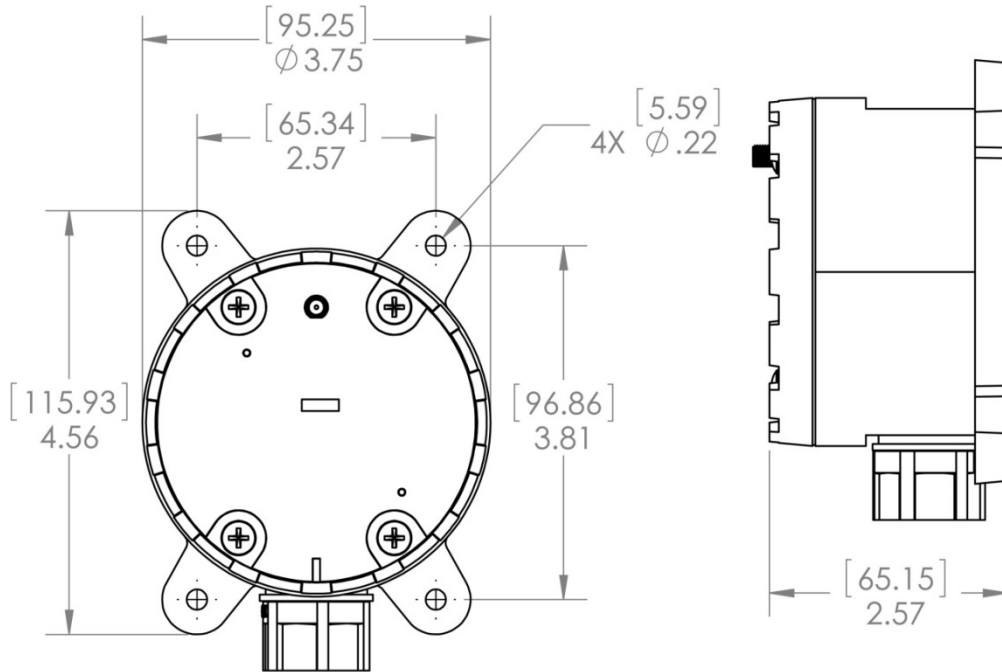

Figure 1: Mechanical Drawing - Wzzard Industrial Models | Units = [millimeters] inches

WZZARD COMMERCIAL NODE MODELS

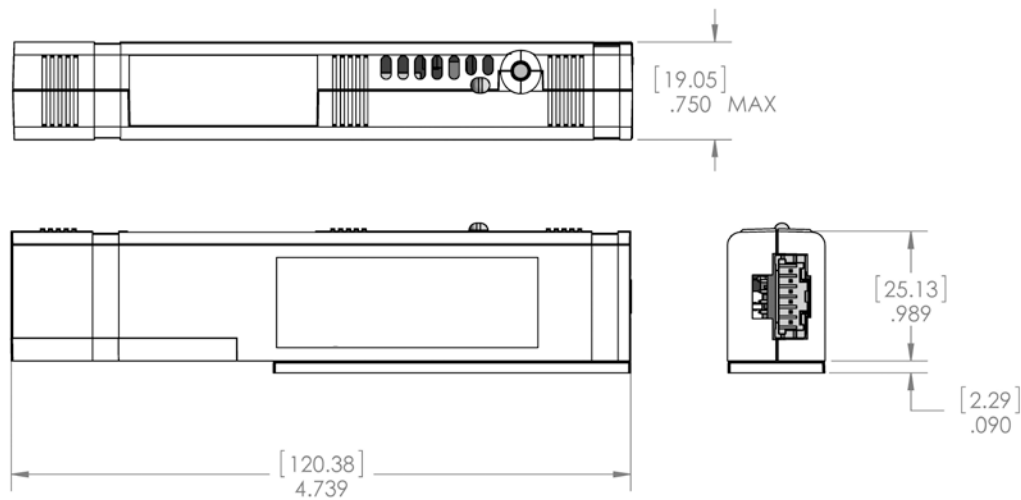

Figure 2: Mechanical Drawing - Wzzard Commercial Model | Units = [millimeters] inches

MODEL NUMBERS

WZZARD MESH WIRELESS SENSORS – INDUSTRIAL NODES

Model Number	Description	UL C1/D2 Applications
BB-WSD2C31010	Wzzard Mesh Wireless Sensor - Industrial Power Monitor Node - Conduit _Sensor Inputs: (3) Analog Inputs (1) Digital Input (1) Internal Temperature	Indoor / Outdoor, w/ mounting ear installation
BB-WSD2M31010	Wzzard Mesh Wireless Sensor – Industrial Power Monitor Node – M12 _Sensor Inputs: (3) Analog Inputs (1) Digital Input (1) Internal Temperature	Indoor Only, w/ mounting ear installation
BB-WSD2C21150	Wzzard Mesh Wireless Sensor - Industrial Cooler/HVAC Node - Conduit _Sensor Inputs: (2) Analog Inputs (1) Digital Input (1) Digital Output (2) Thermocouples (2) Thermistors (1) Internal Temperature	Indoor / Outdoor, w/ mounting ear installation

WZZARD MESH WIRELESS SENSORS – COMMERCIAL NODES

Model Number	Description	UL C1/D2 Applications
BB-WCD1H2102H	Wzzard Mesh Wireless 802.15.4e Sensor - Commercial Cooler HVAC Node _Sensor Inputs: (2) Analog Inputs 0-10VDC or 0-20mA (Software Selectable) (1) Internal Temperature (1) Thermistor 10K @ 25 °C (1) Digital Input (0 - 48V DC) (1) Internal Humidity	UL C1/D2 rating is voided if: _ using M12 model outdoors. _ using magnetic mounting for permanent installation. _ using non UL-specified batteries.

DECLARATION OF COMPLIANCE

CERTIFICATE OF COMPLIANCE

Certificate Number 20171219-E245458
Report Reference E245458-20171218
Issue Date 2017-DECEMBER-19

Issued to: B+B SmartWorx Inc
707 DAYTON RD
OTTAWA IL 61350

This is to certify that
representative samples of

PROGRAMMABLE CONTROLLERS FOR USE IN
HAZARDOUS LOCATIONS
Class I, Division 2, Groups A, B, C, and D Hazardous
Locations. Wizzard Edge Nodes, intelligent wireless mesh
sensor platforms. Models WSD2M31010, WSD2C21150,
WSD2C31010, WSD2C01111, and WSD2M01111.

Have been investigated by UL in accordance with the
Standard(s) indicated on this Certificate.

Standard(s) for Safety: Please see addendum
Additional Information: See the UL Online Certifications Directory at
www.ul.com/database for additional information

Only those products bearing the UL Certification Mark should be considered as being covered by UL's
Certification and Follow-Up Service.

Look for the UL Certification Mark on the product.

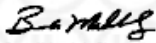

Bruce Mahrenholz, Director North American Certification Program
UL LLC

Any information and documentation involving UL Mark services are provided on behalf of UL LLC (UL) or any authorized licensee of UL. For questions, please
contact a local UL Customer Service Representative at <http://ul.com/about/locations>



CERTIFICATE OF COMPLIANCE

Certificate Number	20171219-E245458
Report Reference	E245458-20171218
Issue Date	2017-DECEMBER-19

This is to certify that representative samples of the product as specified on this certificate were tested according to the current UL requirements.

ANSI/ISA 12.12.01-2015, Nonincendive Electrical Equipment for Use in Class I and II, Division 2 and Class III, Division 1 and 2 Hazardous (Classified) Locations

UL 61010-1 SAFETY REQUIREMENTS FOR ELECTRICAL EQUIPMENT FOR MEASUREMENT, CONTROL, AND LABORATORY USE - PART 1: GENERAL REQUIREMENTS

UL 61010-2-201 STANDARD FOR SAFETY REQUIREMENTS FOR ELECTRICAL EQUIPMENT FOR MEASUREMENT, CONTROL, AND LABORATORY USE - PART 2-201:

PARTICULAR REQUIREMENTS FOR CONTROL EQUIPMENT - Edition 1 - Issue Date 2014/01/24
UL 50E SAFETY FOR ENCLOSURES FOR ELECTRICAL EQUIPMENT, ENVIRONMENTAL CONSIDERATIONS

C22.2 No. 213-M1987 "Non-incendive Electrical Equipment for Use in Class I, Division 2 Hazardous Locations" and C22.2 No. 142-M1987 "Process Control Equipment"

CSA C22.2 NO. 61010-1-12 SAFETY REQUIREMENTS FOR ELECTRICAL EQUIPMENT FOR MEASUREMENT, CONTROL, AND LABORATORY USE. PT. 1, GENERAL REQUIREMENTS

CSA C22.2 NO. 61010-2-201:14 SAFETY REQUIREMENTS FOR ELECTRICAL EQUIPMENT FOR MEASUREMENT, CONTROL, AND LABORATORY USE - PART 2-201: PARTICULAR REQUIREMENTS FOR CONTROL EQUIPMENT

CSA C22.2 NO. 94.2 ENCLOSURES FOR ELECTRICAL EQUIPMENT, ENVIRONMENTAL CONSIDERATIONS

Bruce Mahrenholz, Director North American Certification Program
UL LLC

Any information and documentation involving UL Mark services are provided on behalf of UL LLC (UL) or any authorized licensee of UL. For questions, please contact a local UL Customer Service Representative at <http://ul.com/about/usa/locations>



DECLARATION OF CONFORMITY - CE



Declaration of Conformity

- CORPORATE HEADQUARTERS

707 Dayton Road
PO Box 1040
Ottawa, IL 61350
USA

p: (800) 346-3119
f: (815) 433-5109

- EUROPEAN HEADQUARTERS

Westlink Commercial Park
Unit 10
Oranmore, Co. Galway
Ireland

p: + 353 91 792444
f: + 353 91 792445

- CELLULAR PRODUCTS GROUP

Sokolská 71
562 04 Ústí nad Orlicí, Ill.
Czech Republic

p: +420 465 521 020
f: +420 464 647 299

The undersigned representing the following supplier:

B+B SmartWorx, Inc.
707 Dayton Road
Ottawa, Illinois 61350 USA

Herewith declare under our sole responsibility:

Model Numbers	Description
1. WSD2M31010	WZZARD MESH IND POWER MONITOR NODE - M12
2. WSD2C21150	WZZARD MESH IND COOLER/HVAC NODE - CONDUIT
3. WSD2C31010	WZZARD MESH IND POWER MONITOR NODE - CONDUIT
4. WSD2C01111	WZZARD MESH IND POWER MONITOR NODE - CONDUIT, I2C BUS
5. WSD2M01111	WZZARD MESH IND POWER MONITOR NODE - M12, I2C BUS

These products are in conformity with the provisions of the following directives when used in accordance with the instructions contained in the product documentation.

2014/35/EU	Low Voltage Directive
2014/53/EU	Radio Equipment Directive
2011/65/EU	Reduction of Hazardous Substances Directive
2012/19/EU	Waste electrical and electronic equipment (WEEE) Directive

The standards referenced below have been applied:

EMC: ETSI EN 300 328 v2.1.1 (2016)	EMC & Radio Spectrum Matters (ERM)
ETSI EN 301 489-1 V2.1.1 (2017)	Wideband Transmission Systems, 2.4 GHz ISM Band
ETSI EN 301 489-17 V3.2.0 (2017)	Applied in accordance with the specific requirements of: EMC and Radio Spectrum Matters: Broadband Data Systems
EN 55032:2012+AC:2013, Class A	Information technology equipment – RF Emissions
EN 55024:2010	Information Technology Equipment – Immunity Characteristics – Limits and methods of measurement
Safety: EN/IEC 61010-1:2010 (3rd Ed.)	Safety requirements for electrical equipment for measurement, control, and laboratory use. General requirements
EN/IEC 61010-2-201:2013 (1st Ed.)	Particular requirements for control equipment
RF Exposure: EN 62479:2010	Assessment of the compliance of low power electronic and electrical equipment with the basic restrictions related to human exposure to electromagnetic fields (10 MHz to 300 GHz)

The authorized representative located within the community maintains a copy of the technical documentation required by the directives, at B+B SmartWorx, Inc., Westlink Commercial Park, Oranmore, Co. Galway, Ireland, Phone: +353 91 792444, Email: eSales@advantech-bb.com.

ADVANTECH

**B+B
SMARTWORX**

Photos:



Frequency Range: 2405 TO 2475 MHz

Maximum Output Power (EIRP): +9.9 dBm (B+B 505-10369-00, Dust-type RF module, external antenna)

I hereby declare that the product named above meets the essential requirements of, is in conformity with, and the CE mark has been applied according to, the relevant European directives listed above using the relevant sections of the European Standards and other normative documents listed above.

David Kilniskis
Director of Operations
B+B SmartWorx, Inc.

Date: January 05, 2018
Place: Ottawa, Illinois, USA

ADVANTECH B+B SMARTWORX - TECHNICAL SUPPORT

Phone: 1 (800) 346-3119
Fax: 1 (815) 433-5109
Email: support@advantech-bb.com
Website: www.advantech-bb.com