

LTE Industrial Router

**ICR-1601**

USER MANUAL



**ADVANTECH**

## **Advantech B+B SmartWorx – Americas**

**Advantech B+B SmartWorx**

707 Dayton Road  
Ottawa, IL 61350 USA

**Website**

[www.advantech-bb.com](http://www.advantech-bb.com)

## **Advantech B+B SmartWorx – Europe**

**Advantech B+B SmartWorx s.r.o.**

Sokolska 71  
562 04, Usti nad Orlici,  
Czech Republic

**Website**

[www.advantech-bb.com](http://www.advantech-bb.com)

© 2019 Advantech B+B SmartWorx s.r.o. No part of this publication may be reproduced or transmitted in any form or by any means, electronic or mechanical, including photography, recording, or any information storage and retrieval system without written consent. Information in this manual is subject to change without notice, and does not represent a commitment on the part of Advantech B+B SmartWorx.

Advantech B+B SmartWorx s.r.o. shall not be liable for incidental or consequential damages resulting from the furnishing, performance, or use of this manual.

All brand names used in this manual are the registered trademarks of their respective owners. The use of trademarks or other designations in this publication is for reference purposes only and does not constitute an endorsement by the trademark holder.

## Used symbols



*Danger* – Information regarding user safety or potential damage to the router.



*Attention* – Problems that can arise in specific situations.



*Information, notice* – Useful tips or information of special interest.

## GPL licence

Source codes under GPL licence are available free of charge by sending an email to:  
techSupport@advantech-bb.com.

Please see <http://ep.advantech-bb.cz/devzone> for more information.



# Contents

<b>1</b>	<b>Safety Instructions</b>	<b>2</b>
<b>2</b>	<b>WEEE directive</b>	<b>3</b>
<b>3</b>	<b>Router Description</b>	<b>4</b>
3.1	LTE Category 4 (Cat.4)	4
3.2	Basic HW Information	4
3.3	Configuration and Diagnostics	4
3.4	Usage of the Router	5
<b>4</b>	<b>Contents of Package</b>	<b>7</b>
<b>5</b>	<b>Router Design</b>	<b>8</b>
5.1	Router Versions	8
5.2	Order Codes	8
5.3	Product labels	9
5.4	Basic Dimensions of the Router	10
5.4.1	Left view	10
5.4.2	Bottom view	10
5.5	Description of the Right Panel	11
5.6	Description of the Left Panel	12
5.6.1	Status Indication	13
5.6.2	Power Supply	14
5.6.3	Antenna Connector ANT, DIV and WiFi/GPS	15
5.6.4	SIM Card Reader	16
5.6.5	MicroSD Card Reader	17
5.6.6	Ethernet Ports	18
5.6.7	Factory Reset	19
5.7	Mounting recommendations	20
5.8	The DIN rail clip	21
<b>6</b>	<b>First Use</b>	<b>23</b>
6.1	Connecting the Router	23
6.2	Start	23
6.2.1	Configuration by web browser	23
<b>7</b>	<b>Technical Parameters</b>	<b>25</b>
7.1	Basic Parameters	25

7.2	Technical specification of user interfaces . . . . .	25
7.3	Standards and regulations . . . . .	26
7.4	Type Tests and Environmental Conditions . . . . .	26
7.5	Technical Parameters of Cellular Module . . . . .	27
7.6	Technical Parameters of WiFi . . . . .	28
<b>8</b>	<b>Recommended Literature</b>	<b>29</b>
<b>9</b>	<b>Customers Support</b>	<b>30</b>
9.1	Customer Support for NAM . . . . .	30
9.2	Customer Support for Europe . . . . .	30
9.3	Customer Support for Asia . . . . .	30

# List of Figures

1	Access to the Internet from LAN . . . . .	5
2	Backed up access to the Internet . . . . .	6
3	Using a VPN tunnel . . . . .	6
4	Product label for GPS version . . . . .	9
5	Product label for WiFi version . . . . .	9
6	Left view . . . . .	10
7	Bottom view . . . . .	10
8	Right panel . . . . .	11
9	GPS version . . . . .	12
10	WiFi version . . . . .	12
11	Power adapter . . . . .	14
12	Connecting the antenna . . . . .	15
13	Installation of SIM cards . . . . .	16
14	Installation of microSD memory card . . . . .	17
15	Ethernet connector . . . . .	18
16	Connection of Ethernet cable . . . . .	18
17	Router reset . . . . .	19
18	Installation of the DIN rail clips . . . . .	21
19	Installation to the DIN rail . . . . .	21
20	Removing from the DIN rail . . . . .	22
21	The default IP address of the router . . . . .	23
22	Entering login information . . . . .	23
23	Router web interface . . . . .	24

# List of Tables

1	Contents of package . . . . .	7
1	Router versions . . . . .	8
2	Order codes overview . . . . .	8
3	LED status indication . . . . .	13
4	Connection of Ethernet connector . . . . .	18
5	Basic parameters . . . . .	25
6	Technical specification of user interfaces . . . . .	25
7	Standards and regulations . . . . .	26
8	Type tests and environmental conditions . . . . .	26
9	Technical parameters of cellular module . . . . .	27
10	Technical parameters of WiFi . . . . .	28

# 1. Safety Instructions



**Please, observe the following instructions:**

- The router must be used in compliance with all applicable international and national laws and in compliance with any special restrictions regulating the utilization of the router in prescribed applications and environments.
- To prevent possible injury and damage to appliances and to ensure compliance with all relevant provisions, use only the original accessories. Unauthorized modifications or the use of unapproved accessories may result in damage to the router and/or a breach of applicable regulations. Unauthorized modifications or use of unapproved accessories may void the warranty.
- The router can not be opened.
- Turn off the router and disconnect it from power supply before handling the SIM card.



- **Caution!** The SIM card could be swallowed by small children.
- Input voltage must not exceed 18 V DC max.
- Do not expose the router to extreme ambient conditions. Protect the router against dust, moisture and high temperature.
- Only routers with appropriate certification and labelling should be used in locations where flammable and explosive materials are present, including gas stations, chemical plants, or locations in which explosives are used. We remind users of the duty to observe the restrictions concerning the utilization of radio devices at such places.
- Switch off the router when traveling by plane. Utilization of the router on a plane may endanger the operation of the plane or interfere with the mobile telephone network, and may be unlawful. Failure to observe these instructions may result in the suspension or cancellation of telephone services for the respective client and/or may result in legal sanctions.
- When using the router in close proximity to personal medical devices, such as cardiac pacemakers or hearing aids, you must proceed with heightened caution.
- The router may cause interference when used in close proximity to TV sets, radio receivers or personal computers.
- It is recommended that you create an appropriate copy or backup of all important settings that are stored in the memory of the device.



## 2. Product Disposal Instructions

The WEEE (Waste Electrical and Electronic Equipment: 2012/19/EU) directive was introduced to ensure that electrical/electronic products are recycled using the best available recovery techniques in order to minimize impact on the environment. This product contains high quality materials and components which can be recycled. At the end of its life this product **MUST NOT** be mixed with other commercial waste for disposal. The device contains the battery. Remove the battery from the device before disposal. The battery in the device needs to be disposed apart accordingly. Check the terms and conditions of your supplier for disposal information.

## 3. Router Description

Cellular router ICR-1601 is designed for wireless communication in the mobile networks that make use of traditional cellular technologies. The primary purpose of this router is its use in the newest Category 4 (Cat.4) services on the cellular LTE network.

### 3.1 LTE Category 4 (Cat.4)

LTE Category 4 (Cat.4) is the next step in 4G LTE device capability. Cat.4 rated ICR-1601 routers are capable of achieving better typical speeds in 4G coverage areas where the network is enabled with 20 MHz of contiguous spectrum. The peak downlink data rate for a Category 4 is approximately 150 Mbps. Also in the uplink, LTE Category 4 provides a peak data rate of 50 Mbps.

### 3.2 Basic HW Information

As a standard, the ICR-1601 router is equipped with two Fast Ethernet 10/100 Mbps interfaces, two readers for SIM cards and reader for MicroSD card (log storage). The router can be equipped with WiFi module or with GPS module. This router is supplied in a metal bracket casing.

### 3.3 Configuration and Diagnostics

The ICR-1601 router can be configured using a password-protected Web interface. The web interface provides detailed statistics about the router activities, signal strength, detailed system logs etc.

This device supports the creation of VPN tunnels using technologies IPsec (up to 3 tunnels), OpenVPN, L2TP, PPTP and GRE for secure communications.

There are also supported functions such as IPv6, DHCP, NAT, DNS, DynDNS, NTP, static and dynamic routing, packet filtering, URL blocking, MAC control, IPS, primary connection backups and many other functions. Access using Web, TR-069, SNMP, Telnet and SSH protocols are supported by the router.

Other diagnostic functions ensuring continuous communication include Packet Analyzer and Diagnostic Tools. Using the Command Script editor allows administrator to setup the pre-defined configuration in plain text style and apply the configuration on startup.

The router also supports additional software such as R-SeeNet™ for permanent traffic monitoring of routers.



**Examples of possible applications**

- mobile office
- smart meters for utilities
- fleet management
- security systems
- telematics
- telemetric
- remote monitoring
- vending and dispatcher machines

**3.4 Usage of the Router**

The router is primarily intended for these four basic situations:

**I. Access to the Internet from LAN**

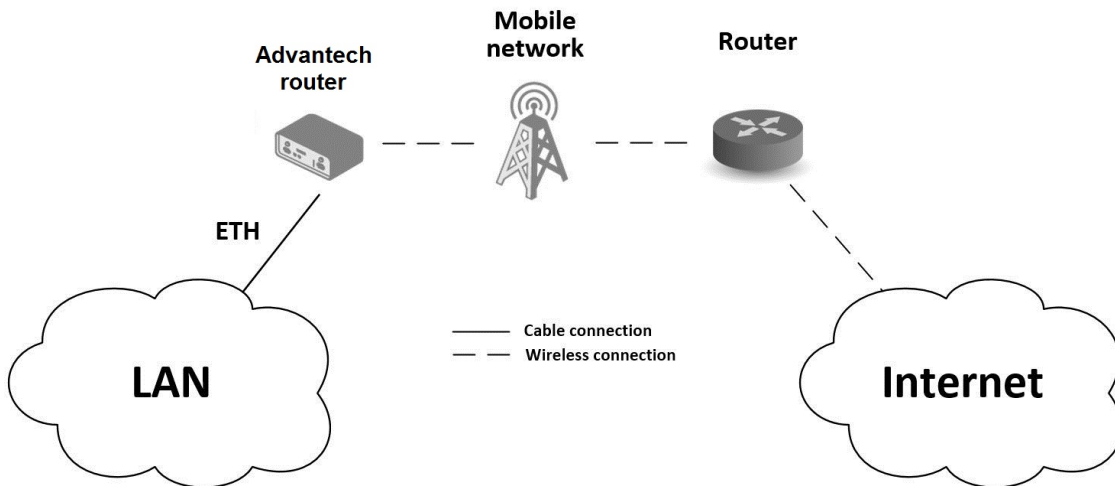

Figure 1: Access to the Internet from LAN

II. Backed up access to the Internet (from LAN)

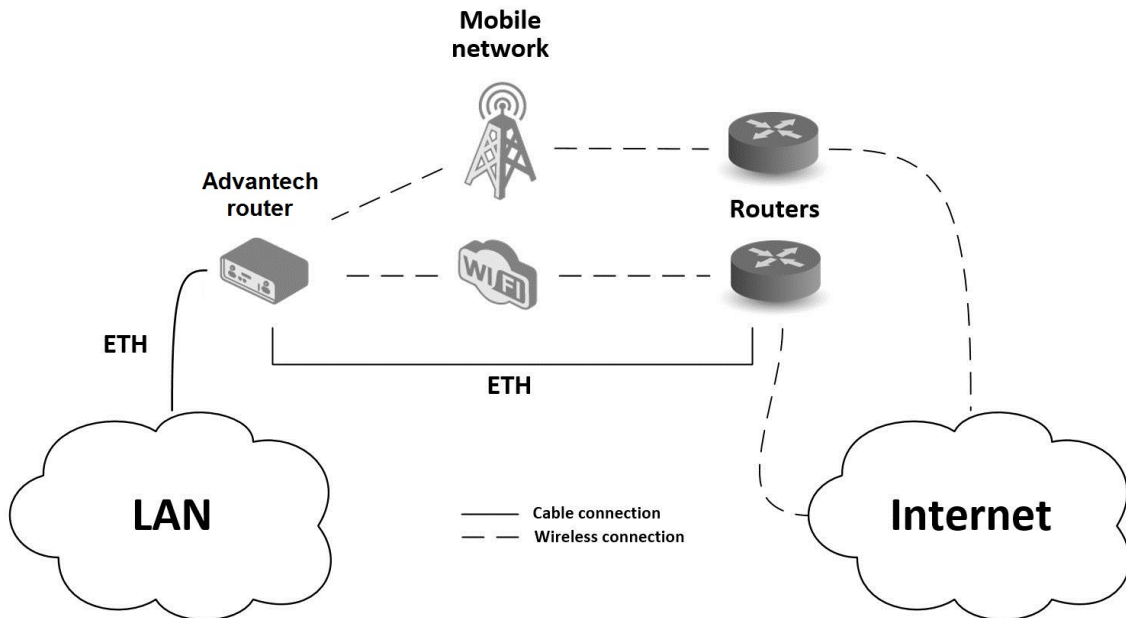

Figure 2: Backed up access to the Internet

III. Secure networks interconnection or using VPN

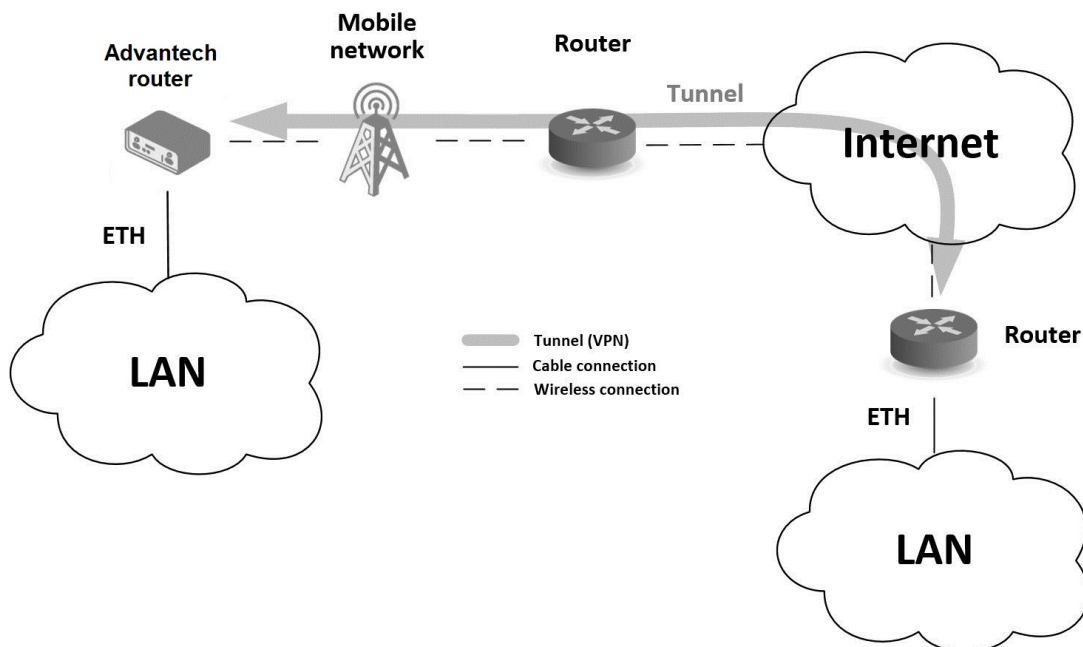

Figure 3: Using a VPN tunnel

## 4. Contents of Package

The standard set of router includes items listed in following table:

Item#	Description	Figure	Q'ty
1	ICR-1601 router		1 pcs
2	Cellular antenna		2 pcs
3	WiFi antenna		1 pcs
4	Power adapter (DC 5V/2A)		1 pcs
5	DIN Rail bracket		1 set
6	Rubber feet		4 pcs
7	Printed Quick Start Guide		1 pcs

Table 1: Contents of package

## 5. Router Design

### 5.1 Router Versions

The ICR-1601 router is supplied in the following versions (see table below). All versions are available only in metal casing.

Router versions	SIM	ETH	GPS	WiFi	MicroSD
ICR-1601 with GPS	2 x	2 x	1 x		1 x
ICR-1601 with WiFi	2 x	2 x		1 x	1 x

Table 1: Router versions

### 5.2 Order Codes

The table below shows an overview of order codes.

Order code	Features – interfaces
ICR-1601G	LTE module Cat.4, 2x ETH, 1x USB, 2x SIM, 1x MicroSD, <b>GPS</b> , accessories
ICR-1601W	LTE module Cat.4, 2x ETH, 1x USB, 2x SIM, 1x MicroSD, <b>WiFi</b> , accessories

Table 2: Order codes overview

## 5.3 Product labels

Product label is placed on the bottom of the router. On pictures below are product labels for both, GPS and WiFi versions.



Figure 4: Product label for GPS version

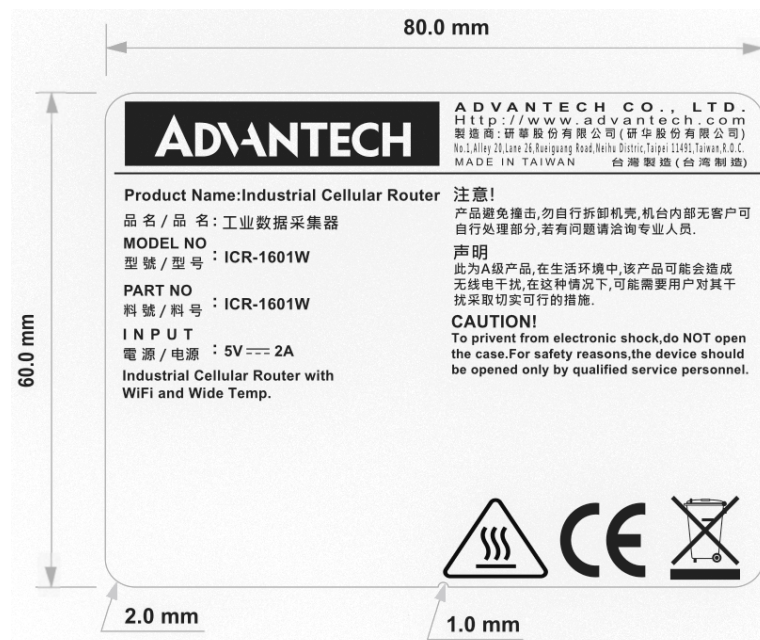

Figure 5: Product label for WiFi version

## 5.4 Basic Dimensions of the Router

### 5.4.1 Left view

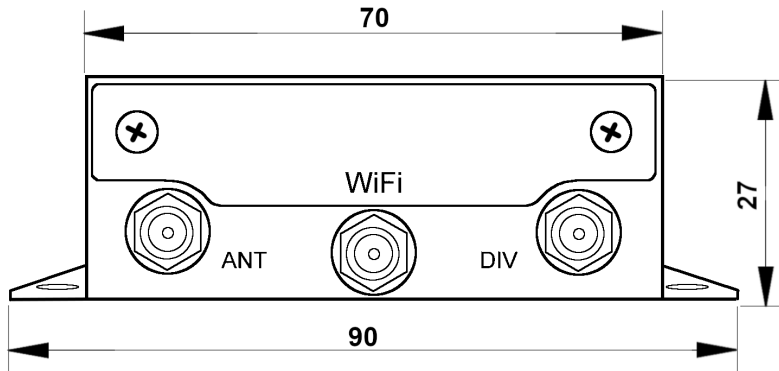

Figure 6: Left view

### 5.4.2 Bottom view

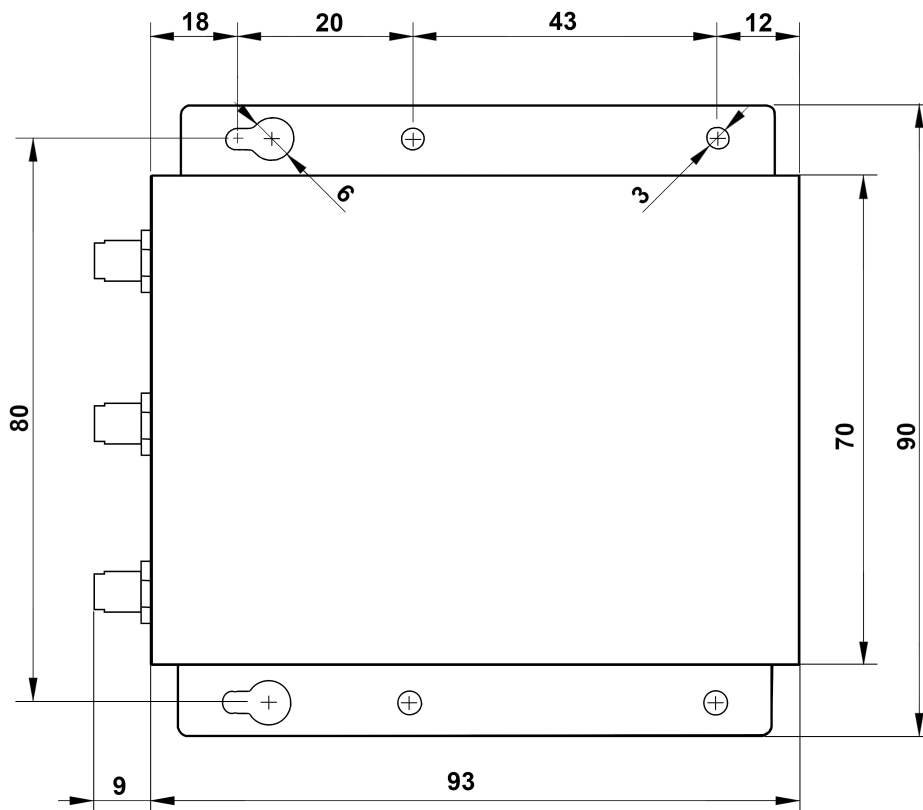

Figure 7: Bottom view



## 5.5 Description of the Right Panel

The right panel is displayed on figure 8.

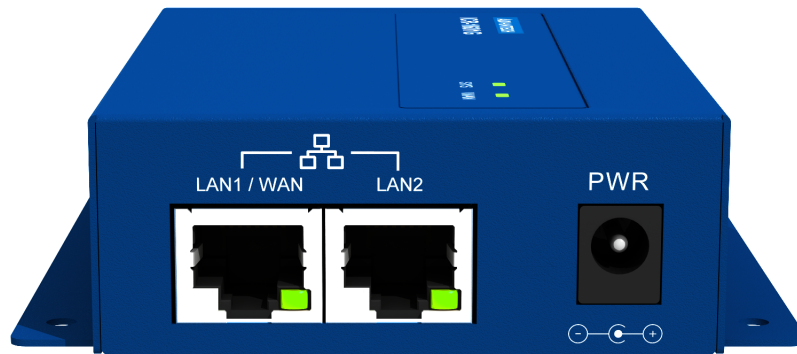

Figure 8: Right panel

The right panel contains:

- **LAN1/WAN** – RJ45 slot for LAN/WAN connection – see chapter 5.6.6,
- **LAN2** – RJ45 slot for LAN connection – see chapter 5.6.6,
- **PWR** – DC power receptacle plug – see chapter 5.6.2.

## 5.6 Description of the Left Panel

The left panel is displayed on figure 9 and 10.

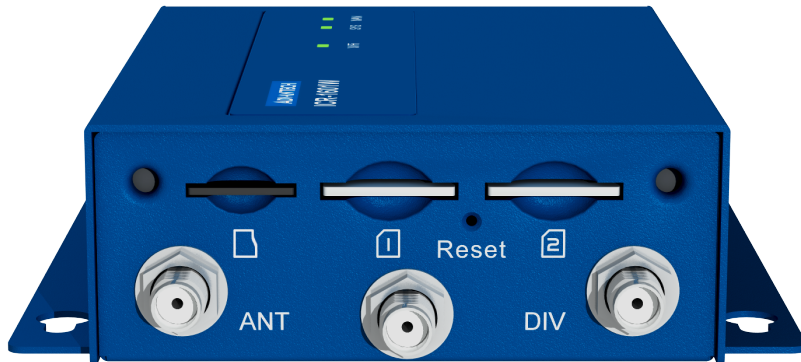

Figure 9: GPS version



Figure 10: WiFi version

The left panel contains:

- **MicroSD** – slot for MicroSD memory card,
- **SIM1** – slot for the first SIM card – see chapter 5.6.5,
- **SIM2** – slot for the second SIM card – see chapter 5.6.4,
- **Reset** – button for factory reset – see chapter 5.6.7,
- **ANT** – SMA connector for cellular antenna – see chapter 5.6.3,
- **WiFi/GPS** – R-SMA connector for WiFi or SMA connector for GPS antenna (based on model) – see chapter 5.6.3,
- **DIV** – SMA connector for diversity cellular antenna – see chapter 5.6.3.

### 5.6.1 Status Indication

There are status LEDs indicators on the top cover to provide router status information. Router with the GPS module has two LEDs while the WiFi version has three LEDs. Each ETH port has one additional LED which provides information about status of the port.

Caption	Color	Description
WiFi <sup>1</sup>	Blue	<b>Off:</b> WiFi radio is disabled. <b>On:</b> WiFi radio is enabled. <b>Flashing:</b> Data packets transferred via WiFi.
SYS	Blue	<b>Flashing (1x per 1 sec.):</b> The router works normally. <b>Flashing fast:</b> The router is in recovery mode or in abnormal situation.
WAN	Blue Purple Red	When the color is: <ul style="list-style-type: none"> <li>• <b>Blue:</b> Cellular module is in LTE mode.</li> <li>• <b>Purple:</b> Cellular module is in HSPA/3G mode.</li> <li>• <b>Red:</b> Cellular module is in GSM/2G mode.</li> </ul> When the behavior of LED is: <ul style="list-style-type: none"> <li>• <b>Flashing fast (1x per 0.5 sec.):</b> Signal strength is 0 ~ 30%.</li> <li>• <b>Flashing slowly (1x per 1 sec.):</b> Signal strength is 31 ~ 60%.</li> <li>• <b>Steady on:</b> Signal strength is 61 ~ 100%.</li> </ul>
ETH	Green	<b>Off:</b> Host disconnected. <b>On:</b> Ethernet connection established. <b>Flashing:</b> Data packets transferred via Ethernet.

Table 3: LED status indication

<sup>1</sup>Only for WiFi versions.

### 5.6.2 Power Supply

There is a DC5V/2A power adapter in the package for you to easily connect DC power to this gateway. Picture of this power adapter is on figure 11. If you power the gateway with other DC Power Source, please make sure the DC Power voltage is in range from 5V to 18V DC. The maximum power consumption of the router is 7 W.



Figure 11: Power adapter



The delivered power adapter is not determined for operating at wide temperature range environment. For operation at full temperature range purchase other industrial power supply with required parameters.



Unit has to be supplied by a power supply specified as a Limited Power Source (LPS) according to clause 2.5 of IEC/UL 60950-1 or CEC/NEC Class 2 source of supply as defined in the Canadian Electrical Code, CSA C22.1 and National Electrical Code, ANSI/NFPA 70. If the power supply/cable provided with device is not used, always use the cables with minimum wire size (nominal cross section) 0.5 square mm for power supply.

### 5.6.3 Antenna Connector ANT, DIV and WiFi/GPS

The main and diversity antennas are connected to the router using the SMA connector on the front panel. In the middle is located R-SMA connector for the WiFi resp. SMA connector for GPS antenna (based on the model). Only passive GPS antennas are supported.

The *ANT* connector is used to connect the main antenna to the router. To connect the diversity antenna, the second antenna connector *DIV* is used.



The router can not operate without a main antenna connected through the port marked as *ANT*!

An SMA connector is used for the connection of the antenna. The antenna is connected by screwing this antenna to the SMA connector on the front panel of the router (see figure below). Recommended tightening moment is 0.9 Nm.

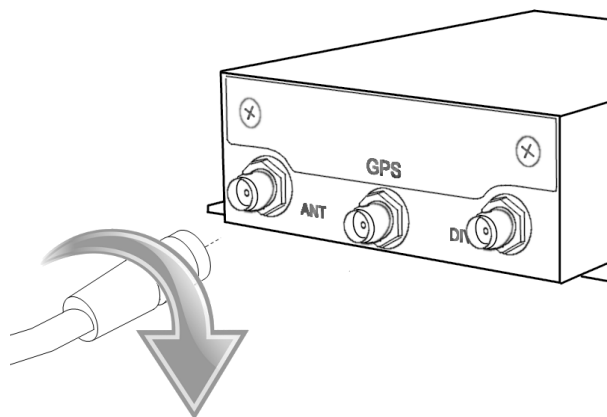

Figure 12: Connecting the antenna



A diversity antenna improves the radio capability of the router at low signal strength.

### 5.6.4 SIM Card Reader



Make sure that the router is powered off prior to inserting or replacing the SIM card.

The two slots for SIM cards are located on the left panel of the router protected by a metal cover. It is necessary to unscrew two screws and remove the metal cover first. Insert the SIM card by pushing it into the slot, see figure below. Push the inserted SIM card again to eject it from the slot. Insert the metal cover back and screw it again.

In order for the router to function, it is necessary to insert an activated SIM card with an unblocked PIN code. The SIM cards may have different adjusted APNs (Access Point Names).

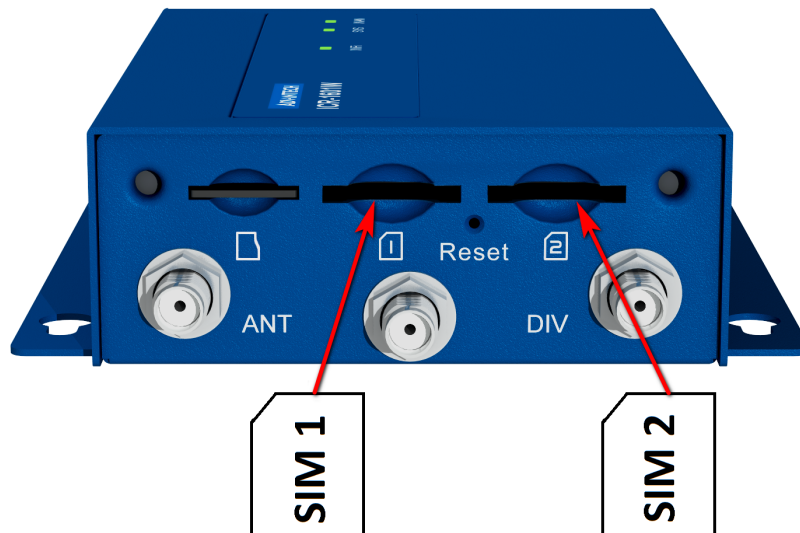

Figure 13: Installation of SIM cards



Supported type of SIM cards: **Micro SIM** (3FF), dimensions 15.0 x 12.0 x 0.76 mm.

### 5.6.5 MicroSD Card Reader



Make sure that the router is powered off prior to inserting or replacing the microSD card.

A microSD memory card can be inserted into the router and used for the log storage. Slot for one microSD memory card is located on the left panel of the router protected by a metal cover. It is necessary to unscrew two screws and remove the metal cover first. Insert the microSD card by pushing it into the slot, see figure below. Push the inserted card again to eject it from the slot. Insert the metal cover back and screw it again.



Supported are SDXC memory cards of class 10 with size up to 32 GB.

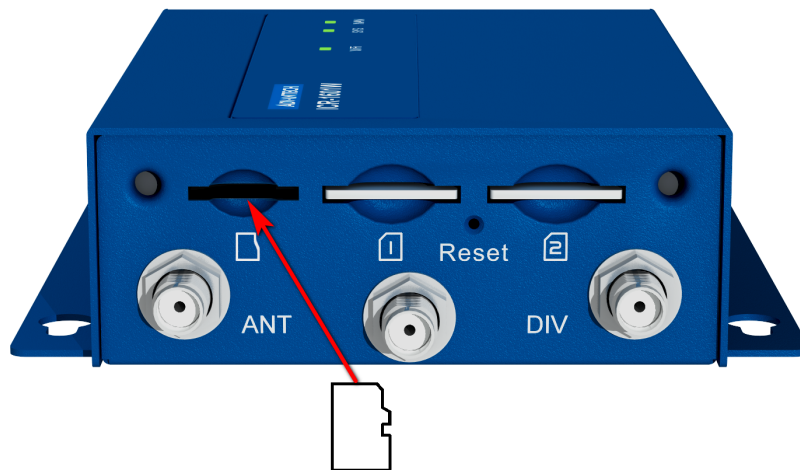

Figure 14: Installation of microSD memory card

### 5.6.6 Ethernet Ports

There are two RJ45 sockets for Fast Ethernet, LAN1 resp. LAN2 interfaces. Only the LAN1 interface can be used for as the WLAN interface.

The connection of the RJ45 Ethernet socket is described in the table below.

Pin	Signal mark	Description	Data flow direction
1	TXD+	Transmit Data – positive pole	Input/Output
2	TXD-	Transmit Data – negative pole	Input/Output
3	RXD+	Receive Data – positive pole	Input/Output
4	—	—	
5	—	—	
6	RXD-	Receive Data – negative pole	Input/Output
7	—	—	
8	—	—	

Table 4: Connection of Ethernet connector

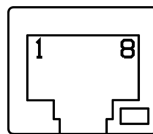

Figure 15: Ethernet connector

Plug the Ethernet cable into the RJ45 connector, see the figure below.

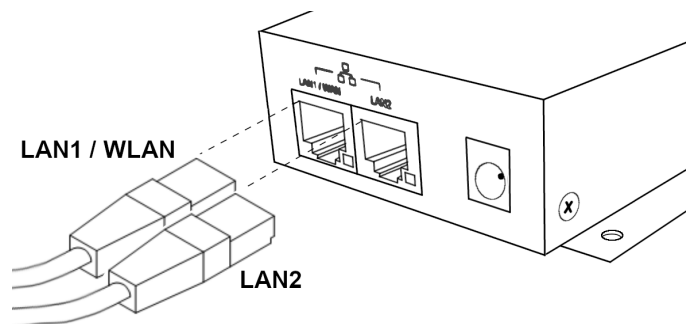

Figure 16: Connection of Ethernet cable



### 5.6.7 Factory Reset

It is possible to restore the default factory configuration of the router by pressing the *Reset* button on the left panel. It is necessary to hold down this button continuously at least for 6 seconds and then release it. After pressing this button, the default factory configuration will be restored and the router will reboot.

It is necessary to use a narrow screwdriver or other small tool in order to press the *Reset* button.



Figure 17: Router reset



All configuration settings will be set to their default states, so it is recommended first to back up the router configuration settings (see *Configuration manual* for more information).

## 5.7 Mounting recommendations

It is possible to place the router:

- on a flat surface,
- on a wall using four holes in corners and screws with diameter 3 mm,
- on DIN rail with the included clip – see chapter 5.8.

It is recommended to follow these instructions:

- For whip antennas it is recommended to observe a minimum distance of 6 cm from cables and metal surfaces on every side in order to avoid interference. When using an external antenna separate from the switchboard it is necessary to fit a lightning conductor.
- When mounting a router on sheet-steel we recommend using a "cable" antenna.
- For all cables we recommend to bind the bunch, and for this we recommend:
  - The length of the bunch (combination of power supply and data cables) should be a maximum 1.5 m. If the length of data cables exceeds 1.5 m or if the cable is leading towards the switchboard, we recommend installing surge protectors.
  - Data cables must not have a reticular tension of  $\sim 230$  V/50 Hz or  $\sim 120$  V/60 Hz.
- Sufficient space must be left between individual connectors for the handling of cables,
- To ensure correct functioning of the router we recommend the use of an earth-bonding distribution frame for the grounding of the power supply of the router, data cables and antenna within the switchboard.

### 5.8 The DIN rail clip

The DIN rail clip supports installation to the TS-32 (G rail), TS-35 (7,5 and 15 mm deep) and TS-15 DIN rails. On the picture below is described assembly of the two DIN rail clips to the router by four screws.

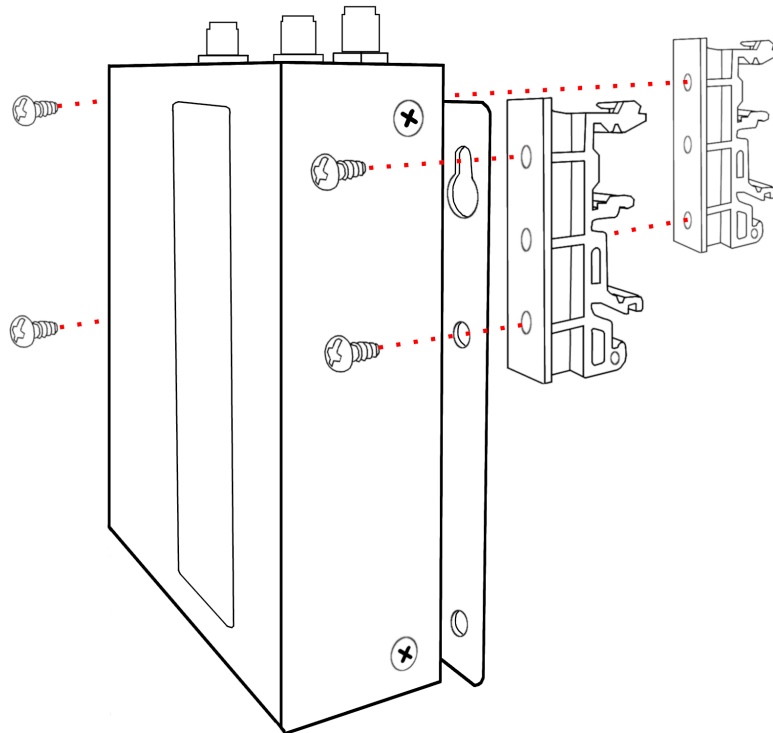

Figure 18: Installation of the DIN rail clips

Installation of the DIN rail clip to the DIN rail of type TS-35-7,5 is illustrated on the picture below.

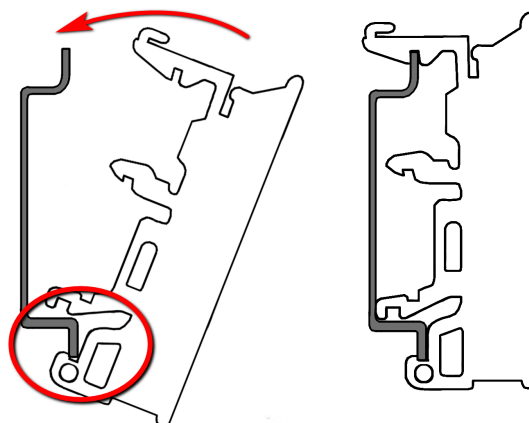

Figure 19: Installation to the DIN rail

In order to remove the DIN rail clip, it is necessary to use a screwdriver as illustrated on following picture.

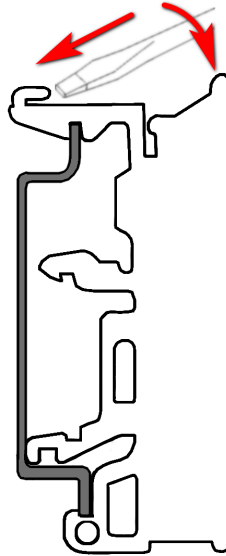

Figure 20: Removing from the DIN rail

## 6. First Use

### 6.1 Connecting the Router

Before putting the router into operation it is necessary to connect all of the components that are required to run your applications. Don't forget to insert a SIM card.



The router can not operate without a connected antenna, SIM card and power supply. If the antenna is not connected, the router may be damaged.

### 6.2 Start

The router will start when a power supply is connected to the router. By default, the router will automatically start to log on to the default APN. The DHCP server will start to assign addresses for devices connected through the Ethernet port ETH. These router behaviors can be changed via the web interface. This is described in detail in the *Configuration manual for ICR-1601* [2].

#### 6.2.1 Configuration by web browser

For status monitoring, configuration and administration of the router, a web interface is available, which can be accessed by entering the IP address of the router into the web browser. The default IP address of the router is **192.168.123.254**.



Figure 21: The default IP address of the router

By default, configuration can only be performed with the default username "admin" and default password "admin".

**Username**  
admin

**Password**  
●●●●●●●●●●●●

Login

Figure 22: Entering login information

Once the login information are entered successfully, the user will have access to the router's web interface via the web browser.

The screenshot shows the Advantech router web interface. At the top right, there is a language dropdown menu set to 'English' and a 'Logout' button. The main navigation menu on the left includes: Status, Basic Network, WAN & Uplink (highlighted), LAN & VLAN, WiFi, IPv6, Port Forwarding, Routing, DNS & DDNS, Object Definition, Security, Administration, and Service. The main content area is titled 'Physical Interface' and 'Connection Setup'. It features a 'Physical Interface List' table with the following data:

Interface Name	Physical Interface	Operation Mode	Action
WAN-1	3G/4G	Always on	<input type="button" value="Edit"/>
WAN-2	-	Disable	<input type="button" value="Edit"/>

Figure 23: Router web interface



A detailed description of the router settings in the Web interface can be found in the *Configuration manual for ICR-1601* [2].

## 7. Technical Parameters

### 7.1 Basic Parameters

ICR-1601		
Temperature range	Operating Storage	-30 °C to +70 °C* -40 °C to +85 °C
Humidity	Operating Storage	10 to 95 % relative humidity non condensing 10 to 95 % relative humidity non condensing
Supply voltage		5 to 18 V DC
Consumption	Maximum	7 W
Dimensions		93 x 90 x 27 mm
Antenna connectors		3x SMA – 50 Ω

Table 5: Basic parameters

### 7.2 Technical specification of user interfaces

	ETH
Connector	RJ45
Min. data rate	10 Mbps
Max. data rate	100 Mbps
Max. total cable length (300 Bd, 200 nF/km)	100 m

Table 6: Technical specification of user interfaces

### 7.3 Standards and regulations

The router complies with the following standards and regulations.

Standards and regulations	
Radio	ETSI EN 301 511 V12.5.1, ETSI EN 301 908-1 V11.1.1, ETSI EN 301 908-2 V11.1.1, ETSI EN 301 908-13 V11.1.1, ETSI EN 303 413 V1.1.1, ETSI EN 300 328 V2.1.1
EMC	ETSI EN 301 489-1 V2.2.0, ETSI EN 301 489-19 V2.1.0, ETSI EN 301 489-52 V1.1.0, ETSI EN 301 489-17 V3.1.1
Safety	EN 60950-1, EN 62368-1, EN 50385, EN 62311
Environmental	RoHS, Reach, WEEE

Table 7: Standards and regulations

### 7.4 Type Tests and Environmental Conditions

Phenomena	Test	Description	Test levels
Dry heat	TBD	Operation	+70 °C
Cold	TBD	Operation	-30 °C
		Storage	-30 °C
Damp heat	TBD	+70 °C, rel. humidity 95%	
Temperature variation	TBD	change -30 °C / +70 °C	

Table 8: Type tests and environmental conditions



## 7.5 Technical Parameters of Cellular Module

Cellular module	
LTE parameters	LTE FDD Cat.4 Bit rate: 150 Mbps (DL) / 50 Mbps (UL) Supported frequencies: B20 (800 MHz), B8 (900 MHz), B3 (1800 MHz), B1 (2100 MHz), B7 (2600 MHz) Transmit power: 23±2.7 dBm
WCDMA parameters	Bit rate: 42.0 Mbps (DL) / 5.76 Mbps (UL) Supported frequencies: B8 (900 MHz), B1 (2100 MHz) Transmit power: 24+1/-3 dBm
GPRS/EDGE parameters	GPRS bit rate: 85.6 kbps (DL) / 85.6 kbps (UL) EDGE bit rate: 236.8 kbps (DL) / 236.8 kbps (UL) GPRS multislot class 10, EDGE multislot class 12 Supported frequencies: 900 MHz, 1800 MHz GSM900 transmit power: 33±2 dBm GSM1800 transmit power: 30±2 dBm

Table 9: Technical parameters of cellular module

### Antenna Requirements

- VSWR – <2:1 (Antenna input impedance response as function of frequency. This shows the antenna resonances and its bandwidth).
- SMA – 50 Ω
- For good diversity performance, the primary and secondary antennas should have different polarizations.

## 7.6 Technical Parameters of WiFi

WiFi	
Antenna connector	R-SMA – 50 $\Omega$
Supported WiFi band	2.4 GHz
Standards	802.11n, 802.11g, 802.11b
2.4 GHz supported channels	1, 2, 3, 4, 5, 6, 7, 8, 9, 10, 11, 12, 13
Functions	Multi-SSID, WMM
Security	WEP, WPA, WPA2, WPA-PSK, WPA2-PSK, 802.1x
Type of device	Access point

Table 10: Technical parameters of WiFi

## 8. Recommended Literature

- [1] Advantech B+B SmartWorx: **Start Guide for ICR-1601,**
- [2] Advantech B+B SmartWorx: **ICR-1601 Configuration Manual.**



Product related documents and applications can be obtained on *Engineering Portal* at <https://ep.advantech-bb.cz/> address.

## 9. Customers Support

### 9.1 Customer Support for NAM

E-mail: [support@advantech-bb.com](mailto:support@advantech-bb.com)

Web: [www.advantech-bb.com](http://www.advantech-bb.com)

### 9.2 Customer Support for Europe

E-mail: [iiotcustomerservice@advantech.eu](mailto:iiotcustomerservice@advantech.eu)

Web: [www.advantech-bb.com](http://www.advantech-bb.com)

### 9.3 Customer Support for Asia

E-mail: [icg.support@advantech.com.tw](mailto:icg.support@advantech.com.tw)

Web: [www.advantech.com](http://www.advantech.com)



#### Upkeep – Advices:

- The SIM-card must be handled carefully as with a credit card. Don't bend, don't scratch on this and do not expose to static electricity.
- During cleaning of the router do not use aggressive chemicals, solvents and abrasive cleaners!

Hereby, Advantech Co., Ltd. company declares that the radio equipment type ICR-1601 is in compliance with EU Directive **2014/53/EU**.

The full text of the EU Declaration of Conformity is available at the following internet address:  
[www.advantech-bb.cz/eudoc](http://www.advantech-bb.cz/eudoc)