

Product Overview

Front View

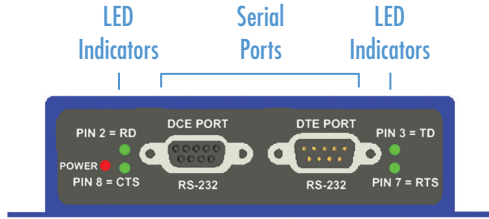

Back View

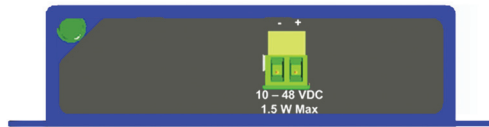

10 to 48 VDC, 1.5 W Max
Grounding the unit is recommended.

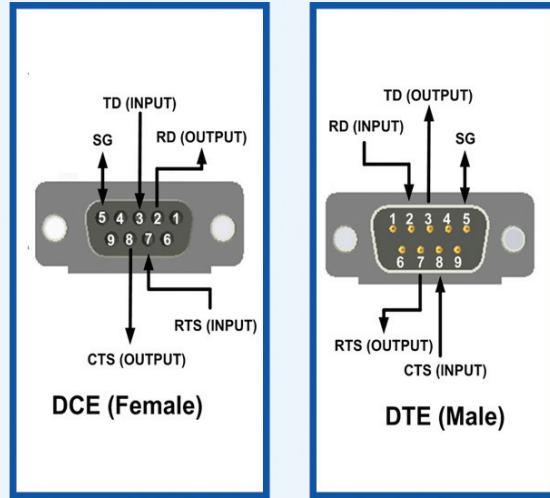

RS-232 Connections

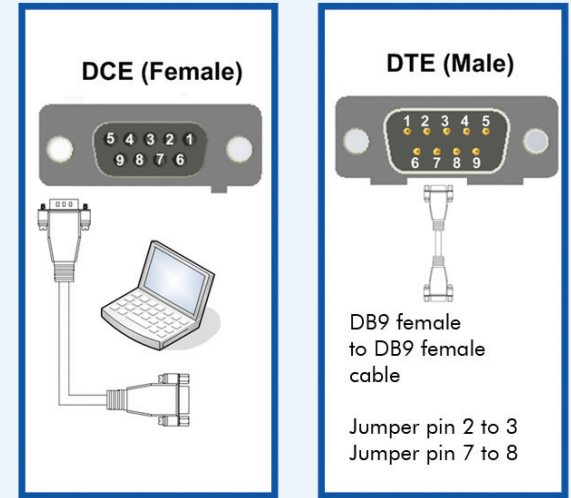

Loopback Test

1 Connect Your RS-232 Devices

A DTE device is “Data Terminal Equipment.” This includes computers, PLCs, and most devices that are not used to extend communications.

(Think “COMPUTER” for DTE.)

A DCE device is “Data Communications Equipment.” This includes modems and other devices that extend communications, like RS-422, RS-485, fiber optic converters or radio modems.

(Think “MODEM” for DCE.)

When connecting a DTE device to a DCE device, use a straight through connection. When connecting a DTE device to a DTE device, or a DCE device to a DCE device, use a crossover (null) connection.

2 Loopback Test

- Use a DB9 Female to DB9 Male cable to connect a PC to the DCE port. (Recommended)
- Connect a DB9 Female to DB9 Female cable to the DTE port. On the DTE Port, jumper pin 2 to 3 and pin 7 to 8 on the female end of the cable. This loops TD to RD and CTS to RTS.
- Using HyperTerminal or similar program, connect to the appropriate COM port. (Remember to set the baud rate to 9600.)
- Turn off HyperTerminal local echo.
- Type some characters in HyperTerminal. The same characters should appear on your screen. The LED indicators will light up to show you that data is being transmitted.

3 Check LEDs

DB9 Female	DCE Port
DB9 Male	DTE Port
Pin 3 LED	Green, ON when a TD input (PIN 3) is raised on the DCE port
Pin 7 LED	Green, ON when a RTS input (PIN 7) is raised on the DCE port
Pin 2 LED	Green, ON when a RD input (PIN 2) is raised on the DTE port
Pin 8 LED	Green, ON when a CTS input (PIN 8) is raised on the DTE port
Power LED	Red, ON when power applied
Power TB2	Position, Removable (10-48 VDC)
GND	Grounding Lug

Troubleshooting

Are My Devices Wired As DTE or DCE?

How to Check:

1. *Use Rule of Thumb* - If the device plugs into the computer serial port and works normally, the device is wired as DCE (or the connection cable is a crossover type that makes it work as a DCE). If the device connects to the computer port using a "null modem" crossover cable, it is wired as DTE.
2. *Use RS-232 Line Tester* - A quick and easy way to determine the DTE/DCE port type is to use a RS-232 line tester such as the 9PMTT. The tester can show the signal state of any active RS-232 data lines using LEDs lighting Red or Green. Active data lines are output from a device. They may be either High or Low.

Information – UL Class 1 Div 2

1. Power, Input/Output (I/O) wiring for the end use enclosure must be in accordance with Class 1, Division 2 wiring methods (Article 501.10(B) of the National Electric Code, NFPA 70) and in accordance with the local authority having jurisdiction.
2. The temperature rating of field-installed conductors is 105°C. Use copper wire only.
3. Maximum ambient air temperature is 85°C.
4. These devices must be installed in end use enclosures suitable for the location.
5. **WARNING – EXPLOSION HAZARD:** Substitution of any components may impair suitability for Class 1, Division 2.
6. **WARNING – EXPLOSION HAZARD:** Do not disconnect equipment unless power has been switched off or the area is known to be non-hazardous.
7. **WARNING –** This device is suitable for use in Class 1, Division 2, Groups A, B, C, and D or in non-hazardous locations only.

Document number – p/n 8514 r002 232OPDRi-PH - 0812

Recommended Accessories and Power Supplies

Industrial Power Supply

<http://www.bb-elec.com/232OPDRi-PH/ACC>



MDR-20-24

Surge Protector

<http://www.bb-elec.com/232OPDRi-PH/ACC>



232HESP

Fast, Easy Answers

- **First, check step 2.**
- **Then use your smart phone to access complete documentation on our web site. Simply scan the code to the right.**



<http://www.bb-elec.com/232OPDRi-PH>



1-888-948-2248 | Europe: +353 91 792444

www.bb-elec.com

707 Dayton Road | PO Box 1040 | Ottawa, IL 61350
Phone: 815-433-5100 | Fax: 815-433-5109
www.bb-elec.com | E-mail: info@bb-elec.com

© 2012 B&B Electronics Manufacturing Company

B&B ELECTRONICS **QUICK START GUIDE**



232OPDRi-PH

RS-232 Repeater with Triple Isolation

✓ First Things First...

Before you begin, be sure you have the following:

- Ilinx 232OPDR-PH RS-232I Isolated Repeater
- Additional items **required** but not included:
 - (1) 10 to 48 VDC Power Supply
 - Two RS-232 Cables
 - Ground Cable

B&B ELECTRONICS
Make The Right Connections

Fast and easy on the web: www.bb-elec.com