

TPC-651H

5.7" VGA TFT LCD Intel® Atom™ Touch Panel Computer with Wide Operating Temperature

NEW



Features

- Intel® Atom™ processor (up to 1.33 GHz)
- 5.7" VGA TFT LCD
- -20 ~ 60° C wide operating temperature
- Compact design with die-cast Al alloy front bezel
- Fanless cooling system
- NEMA4/IP65 compliant front panel
- Supports Microsoft® Windows XP/XPe/CE
- Dual Gigabit Ethernet supported
- Isolation Protection for Serial ports
- Energy Star approval

Introduction

With a high quality TPC product line, TPC extends its Touch Panel Computer family with Intel® Atom™ platform for 5.7", 12.1" & 15". TPC-651H is designed with Intel® Atom™ eMenlow XL processor as its core. The Intel Atom has low power consumption and wide operating temperature. This system is fanless, slim design and the front bezel is die-cast Al alloy material. This product also provides a -20~60° C wide operating temperature solution and complete isolation protection for its serial ports. TPC-651H series are durable and reliable platform.

Specifications

General

- **BIOS** Award® 4 MB
- **Certifications** BSMI, CCC, CE, FCC, UL
- **Cooling System** Fanless design
- **Dimensions (W x H x D)** 195 x 148 x 58 mm (7.68" x 5.83" x 2.28")
- **Enclosure** ABS and ABS + PC
- **Mounting** Panel Mount
- **OS Support** Windows XP/XPe/CE
Linux
- **Power Consumption** 17 W (typical)
- **Power Input** 18 ~ 32 V_{DC}
- **Watchdog Timer** 1 ~ 255 sec (system)
- **Weight (Net)** 1.43 kg (3.15 lb)

System Hardware

- **CPU** Intel Atom 1.33 GHz
- **Chipset** eMenlow XL + Poulsbo
- **Memory** 1GB SO-DIMM DDR2 667 SDRAM
Up to 2GB (One channel)
- **LAN** 10/100/1000Base-T x 2
- **Storage** CompactFlash® slot x 1
- **I/O** RS-232 x 1 (with isolation)
RS-422/485 x 1 (with isolation)
USB 2.0 x 2 (Host)

LCD Display

- **Display Type** VGA TFT LCD
- **Display Size** 5.7"
- **Max. Resolution** 640 x 480
- **Max. Colors** 262 K
- **Luminance cd/m²** 700
- **Viewing Angle (H/V°)** 160/140
- **Backlight Life** 50,000 hrs
- **Contrast Ratio** 800 : 1

Touchscreen

- **Lifespan** 1 million touches at single point
- **Light Transmission** Above 75%
- **Resolution** Linearity
- **Type** 5-wire, analog resistive

Environment

- **Humidity** 10 ~ 95% RH @ 40° C, non-condensing
- **Ingress Protection** Front panel: NEMA4, IP65
- **Operating Temperature** -20 ~ 60° C (-4 ~ 140° F)
- **Storage Temperature** -20 ~ 60° C (-4 ~ 140° F)
- **Vibration Protection** 2 Grms (5 ~ 500 Hz)
(Operating, random vibration)

Dimensions

Unit: mm

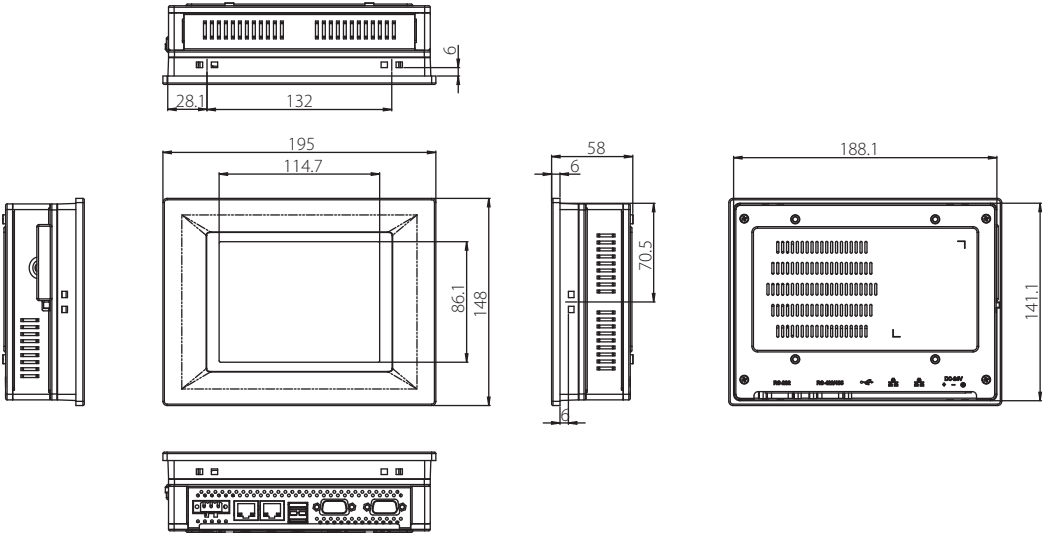

Panel Cut-out Dimensions: 189.1 x 142.1 mm

Ordering Information

- TPC-651H-Z2AE 5.7" VGA Touch Panel PC, Atom Z520 1.33 GHz, 1 GB
- PWR-247-AE 24 V 50 W AC-DC Power Adapter

Rear View

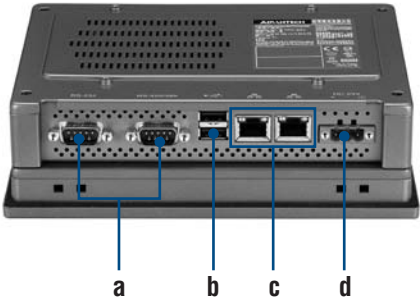

- a. COM (RS-232, RS-422/485)
- b. USB 2.0
- c. LAN (10/100/1000)
- d. Power Receptor