

User' s Manual

RS-100/200-RF
1U/2U e-Server

Copyright Notice

This document is copyrighted, 2001, by Advantech Co., Ltd. All rights are reserved. Advantech Co., Ltd. reserves the right to make improvements to the products described in this manual at any time without notice.

No part of this manual may be reproduced, copied, translated or transmitted in any form or by any means without the prior written permission of the original manufacturer. Information provided in this manual is intended to be accurate and reliable. However, the original manufacturer assumes no responsibility for its use, nor for any infringements upon the rights of third parties that may result from its use.

Acknowledgements

- AWARD is a trademark of AWARD Software, Inc.
- IBM and PC are trademarks of International Business Machines Corporation
- Intel and Pentium III are trademarks of Intel Corporation
- Windows NT 4.0 and Windows 2000 are trademarks of Microsoft Corporation
- LSI and Symbios are registered trademarks of LSI Corporation.
- ATI is a trademark of ATI Technologies, Inc.
- Serverworks is a trademark of Serverworks Corporation

All other product names or trademarks are properties of their respective owners.

CE Notification

RS-100-RF-S3-S3, RS-100-RF-S2-S3, RS-200-RF-S3-S6 and RS-200-RF-R3-S6, developed by Advantech Co., Ltd., has passed the CE test for environment specifications when shielded cables are used for external wiring. We recommend the use of shielded cables.

Part No. 2002000110

1st Edition Printed in Taiwan February 2001

Product Warranty

Advantech warrants to you, the original purchaser, that each of its products will be free from defects in materials and workmanship for two years from the date of purchase.

This warranty does not apply to any products which have been repaired or altered by persons other than repair personnel authorized by Advantech, or which have been subject to misuse, abuse, accident or improper installation. Advantech assumes no liability under the terms of this warranty as a consequence of such events.

Because of Advantech's high quality-control standards and rigorous testing, most of our customers never need to use our repair service. If an Advantech product is defective, it will be repaired or replaced at no charge during the warranty period. For out-of-warranty repairs, you will be billed according to the cost of replacement materials, service time and freight. Please consult your dealer for more details.

If you think you have a defective product, follow these steps:

1. Collect all the information about the problem encountered. For example, CPU speed, Advantech products used, other hardware and software used, etc. Note anything abnormal and list any on-screen messages you get when the problem occurs.
2. Call your dealer and describe the problem. Please have your manual, product, and any helpful information readily available.
3. If your product is diagnosed as defective, obtain an RMA (return merchandise authorization) number from your dealer. This allows us to process your return more quickly.
4. Carefully pack the defective product, a fully completed Repair and Replacement Order Card and a photocopy proof of purchase date (such as your sales receipt) in a shippable container. A product returned without proof of the purchase date is not eligible for warranty service.
5. Write the RMA number visibly on the outside of the package and ship it prepaid to your dealer.

Packing List

You should find the items listed below in the server package. If anything is missing or damaged, please consult with your vendor for resolution.

- 2 CPU Coolers
- 2 Rack Mount Ears
- 6 Screw Sinks
- 1 Power Cord (2 Power Cords for RS-200-RF-R3-S6)
- 1 CD Title
Driver Bank
- 5 Driver Bank Floppy Diskettes:
Linux Red-Hat 6.2 Boot Disk
Linux Red-Hat 6.2 Installation Disk
LSI Symbios 53C1010 SCSI Driver Patch & Intel 82559 Driver for Linux
LSI Symbios 53C1010 SCSI Driver for Windows NT 4.0
LSI Symbios 53C1010 SCSI Driver for Windows 2000
- RS-100/200-RF User' s Manual
- Warrant Card

Technical Support and Sales Assistance

If you have any technical questions about the RS-100/200-RF series products, please visit our support website at

- <http://www.advantech.com.tw/support>

For more information about Advantech products and sales information, please visit:

- <http://www.advantech.com>

Contents

| | |
|--|----|
| Chapter 1 General Information | 7 |
| 1.1 Introduction | 7 |
| 1.2 Specifications | 8 |
| 1.3 External Connections | 12 |
| 1.4 Front Panel Functions | 13 |
| 1.5 Power Supply Rear Panel | 15 |
| 1.6 System Monitoring | 16 |
| | |
| Chapter 2 Hardware Installation | 17 |
| 2.1 Internal Outlook | 17 |
| 2.1.1 Removing The Cover | 17 |
| 2.1.2 System Placement | 18 |
| 2.1.3 Main Board Placement | 20 |
| 2.1.4 Alarm Board Placement | 21 |
| 2.1.5 SCA-2 SCSI Backplane Placement | 22 |
| 2.2 Installing CPU | 24 |
| 2.3 Installing CPU Cooler | 25 |
| 2.4 Installing System Memory | 26 |
| 2.5 Installing Add-on Cards | 28 |
| 2.6 Adding Disk Drives | 31 |
| 2.7 Installing LAN module | 33 |
| | |
| Chapter 3 BIOS Setup | 35 |
| 3.1 Function Keys | 35 |
| 3.2 Main Menu | 36 |
| 3.2.1 Standard CMOS Features | 37 |
| 3.2.2 Advanced BIOS Features | 41 |
| 3.2.3 Integrated Peripheral | 43 |
| 3.2.4 PnP/ PCI Configurations | 45 |
| 3.2.5 Load Optimized Defaults | 46 |
| 3.2.6 Set Password | 47 |
| 3.2.7 Save & Exit Setup | 48 |
| 3.2.8 Exit without Saving | 49 |

| | |
|---|----|
| Chapter 4 OS Installation | 51 |
| 4.1 Installing Windows NT 4.0 Support Driver | 52 |
| 4.2 Installing Windows 2000 Support Driver | 53 |
| 4.3 Installing Linux/ FreeBSD Support Software | 54 |
| 4.3.1 Red Hat Installation Procedures | 54 |
| 4.3.2 Installing SCSI Drivers for Linux | 55 |
| 4.3.3 Installing A Network Driver for Red Hat 6.2 | 56 |
| | |
| Appendix A Memory Approval List | 57 |
| | |
| Appendix B RAID Card Approval List | 58 |
| | |
| Appendix C Driver Bank | 59 |
| | |
| Appendix D Safety Instructions | 62 |
| D.1 English | 62 |
| D.2 German- Wichtige Sicherheishinweise | 63 |

Chapter 1 General Information

1.1 Introduction

The RS-100/200-RF is a 1U/2U high, rack-mountable e-Server for high-density Internet services. Engineered for Internet service providers and enterprises, the RS-100/200-RF's rack-mountable 1U/2U form factor is the best for stacking servers as services grow. The RS-100/200-RF designed for maximum reliability features Dual Intel® Pentium® !!! Processors, and provides the flexibility and high performance at the same time.

The RS-100/200-RF e-Server line of thin servers is well placed to compete at the forefront in this fast-paced product sector. Thin servers are rapidly becoming the platform of choice for Internet and telecom-focused applications. Characterized by being quick to deploy and easy to manage, the RS-100/200-RF e-Server provides flexible solution designed to meet the needs of ISPs, telecommunications applications and space constrained data centers.

The thin servers provide pack powerful hardware configurations into compact form factors that allow flexible installation and replacement. The server-strength hardware includes powerful processors on server-engineered motherboards, flexibly configurable high capacity, high-speed hot-swappable SCSI storage devices, high-speed network interfaces and specially designed fault detection and management features. These all add up to a hardware solution that provides the kind of high availability required by demanding applications.

1.2 Specifications

1.2.1 RS-100-RF

General Specification

| | |
|-----------|---|
| CPU | Dual Intel Pentium !!! up to 866MHz |
| Chipset | Serverworks Serverset III LE chipset, support 133MHz FSB |
| BIOS | Award Flash BIOS 2M-bit |
| Memory | Four DIMM sockets support up to Max. 4GB PC-133 3.3V registered SDRAM with ECC (Max memory size depends on OS support) |
| VGA | Ati RageXL with 8MB SGRAM |
| SCSI | LSI Symbios SYM53C1010 Ultra 160 dual channel controller, Data transfer rate up to 160MB/s. |
| LAN | Triple Intel 82559 Fast Ethernet controllers support 10/100Mbps with RJ-45 connectors. <i>One of 3 LANs is optional.</i> |
| FDD | One slim Floppy Disk Drive |
| CD-ROM | One slim CD-ROM drive |
| Expansion | One 66MHz, 64-bit PCI slot on Riser Card |
| I/O | 1 x RS-232 port, 1 x parallel port, 2 x USB ports, 1 x VGA port, 1 x PS/2 keyboard port, 1 x PS/2 mouse port, 3 x LAN ports (one option), 1 x SCSI port |

System and Environment

| | |
|-------------------|--|
| Construction | 19" Rack Mount, Heavy-duty steel chassis |
| Cooling System | Six 10-CFM cooling fans, 60 CFM in total |
| Controls | Momentary power switch and alarm reset switch |
| Indicators | Power LED, Alarm LED, HDD LEDs and LAN LEDs |
| Storage | Three hot-swap SCA-2 SCSI HDD drive bays, one slim-type FDD drive and one slim CD-ROM drive |
| Power Supply | Slim 300W switching power supply |
| Input | 90~264VAC Full Range @ 47~63Hz |
| Output | +5V/32A (Max), -5V/0.5A (Max), +12V/14A (Max), -12V/0.5A (Max), +3.3V/14A (Max), +5VSB/1.5A (Max) |
| System Monitoring | Integrated server management features including thermal, voltage, fans and power failure monitoring in one controller and an optional SNMP software package for system remote monitoring |
| Weight | 10kg (22lb) |
| Paint Color | Black 1U 1X, Fabric Texture |
| Operating Temp. | 0 ~40 (32 ~104) |
| Storage Temp. | -20 ~70 (-4 ~158) |

| | |
|------------------|---|
| Operating Hum. | 5~95% @ 40 |
| Storage Humidity | 5~95% |
| Dimension | 44mm (1.73") H x 482mm (19") W x 600mm (23.6") D |
| Certifications | FCC Class A, CE, UL |
| OS | Linux, Free BSD 4.x, Windows 2000, Windows NT 4.0 |



1.2.2 RS-200-RF

General Specification

| | |
|-----------|---|
| CPU | Dual Intel Pentium !!! processor up to 1GHz |
| Chipset | Serverworks Serverset III LE chipset, support 133MHz FSB |
| BIOS | Award Flash BIOS 2M-bit |
| Memory | Four DIMM sockets support up to Max. 4GB Registered 3.3V PC-133 SDRAM with ECC (Max. memory size depends on OS support) |
| VGA | Ati RageXL with 8MB SGRAM |
| SCSI | LSI Symbios SYM53C1010 Ultra 160 dual channel controller, Data transfer rate up to 160MB/s. |
| LAN | Triple Intel 82559 Fast Ethernet controllers support 10/100Mbps with RJ-45 connectors. <i>One of 3 LANs is optional.</i> |
| FDD | One slim Floppy Disk Drive |
| CD-ROM | One slim CD-ROM drive |
| Expansion | One 66MHz/64-bit PCI slot or three 33MHz/64-bit PCI slots on riser card |
| I/O | 1 x RS-232 port, 1 x parallel port, 2 x USB ports, 1 x VGA port, 1 x PS/2 keyboard port, 1 x PS/2 mouse port, 3 x LAN ports (one option), 1 x SCSI port |

System and Environment

| | |
|-------------------|--|
| Construction | 19" Rack Mount, Heavy-duty steel chassis |
| Cooling System | Four 39-CFM cooling fans and one 10-CFM cooling fan, 166 CFM in total |
| Controls | Momentary power switch and alarm reset switch |
| Indicators | Power LED, Over-temperature LED, Voltage failure LED, Fan failure LED, HDD LEDs and LAN LEDs |
| Storage | Six hot-swap SCA-2 SCSI HDD drive bays, one slim-type FDD drive and one slim CD-ROM drive |
| Power Supply | Slim 300W switching power supply (SPS) or Redundant 300W (1+1) SPS |
| Input | 90~264VAC Full Range @ 47~63Hz |
| Output | +5V/32A (Max), -5V/0.5A (Max), +12V/14A (Max), -12V/0.5A (Max), +3.3V/14A (Max), +5VSB/1.5A (Max) |
| System Monitoring | Integrated server management features including thermal, voltage, fans and power failure monitoring in one controller and an optional SNMP software package for system remote monitoring |
| Weight | 12.9kg/ (28.4lb), 14.4kg/(31.7lb) for Redundant Switching Power Supply |
| Paint Color | Black 2U 2X, Fabric Texture |
| Operating Temp. | 0 ~40 (32 ~104) |
| Storage Temp. | -20 ~75 (-4 ~167) |

| | |
|------------------|---|
| Operating Hum. | 5~95% @ 40 |
| Storage Humidity | 5~95% |
| Dimension | 88mm (3.46") H x 482mm (19") W x 600mm (23.6") D |
| Certifications | FCC Class A, CE, UL |
| OS | Linux, Free BSD 4.x, Windows 2000, Windows NT 4.0 |



1.3 External Connection

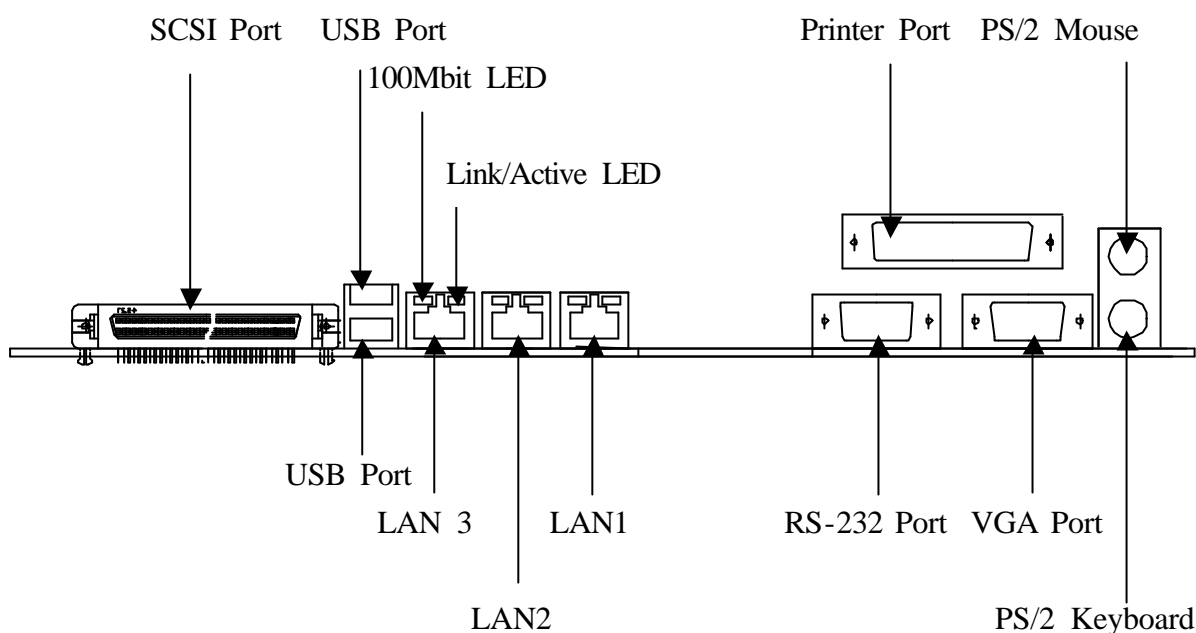

SCSI Connector: The serverboard provides a 68-pin Ultra-160 connector for extending SCSI storage devices.

Dual USB Connectors (Two 4-pin Female): Two USB ports are available for attaching USB devices. User can plug USB device directly to the USB connector.

LAN Connectors (8-pin): The serverboard provides three LAN connectors with two status LEDs. One LED indicates whether 100Mbit protocol is active. Another one indicates whether LAN is active or at linking.

Printer Port Connector: The serverboard provides a 25-pin female centronic connector for LPT. The parallel port is a standard printer port that also supports Enhanced Parallel Port (EPP) and Extended capabilities Parallel Port (ECP).

PS/2 Mouse Connector (6-pin Female): The connector is for a standard PS/2 mouse only.

Serial Port Connector: The serverboard has one 9-pin male DIN connector for RS-232 port.

VGA port Connector (15-pin D-SUB): The port allows user connect it to external Monitor.

PS/2 Keyboard Connector: The connector is for a standard PS/2 keyboard only.

1.4 Front Panel Functions

1.4.1 RS-100-RF

- Front Panel Control

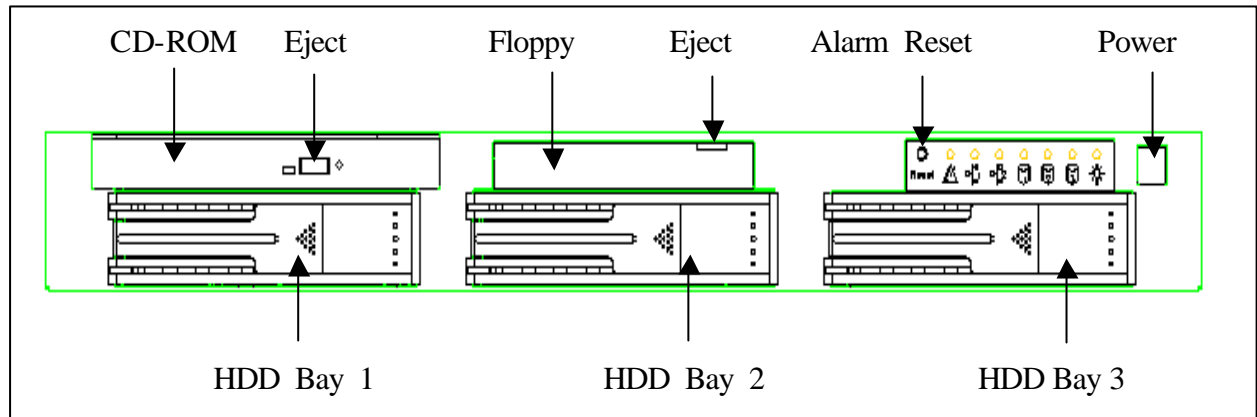

- System Status Panel

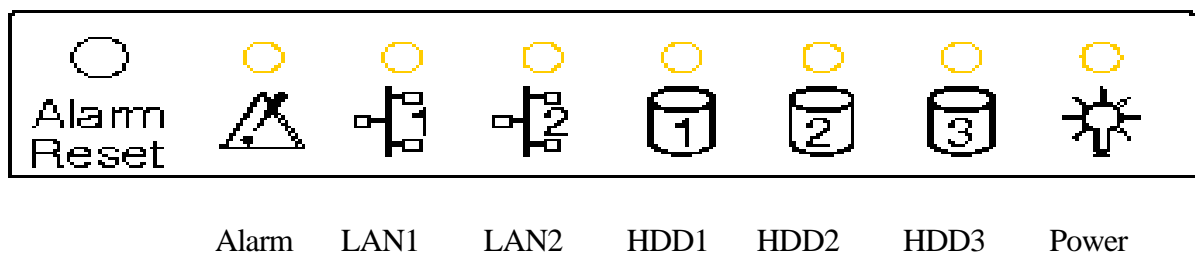

| | Indicator | Description |
|-------|-----------|--|
| Alarm | Red | Indicate voltage, temperature, fan failure |
| LAN 1 | Green | Active |
| LAN 2 | Green | Active |
| HDD 1 | Green | Active |
| HDD 2 | Green | Active |
| HDD 3 | Green | Active |
| Power | Green | Power-on |
| | Orange | Standby |

1.4.2 RS-200-RF

- Front Panel

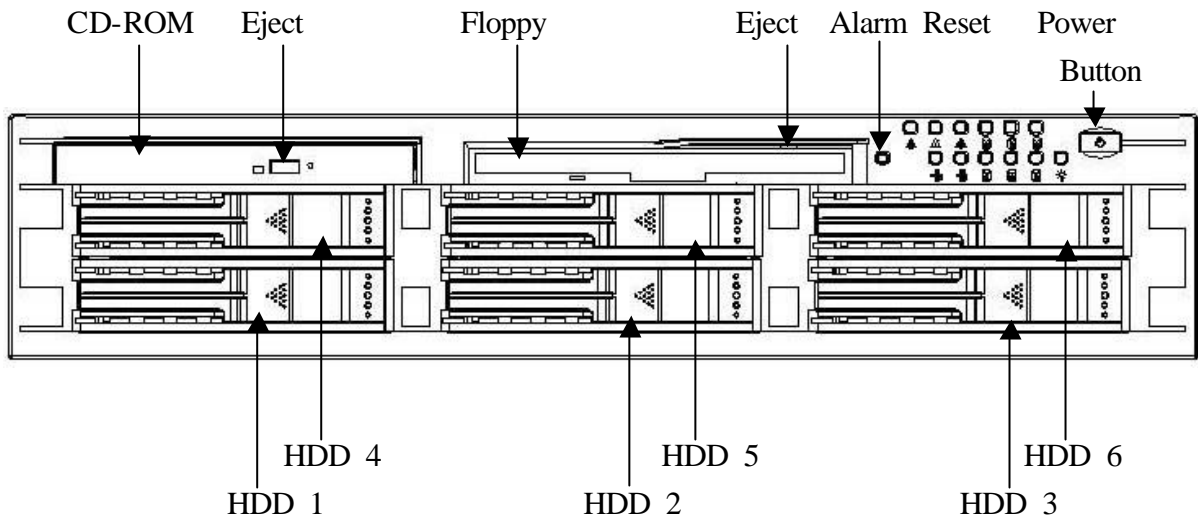

- System Status Panel

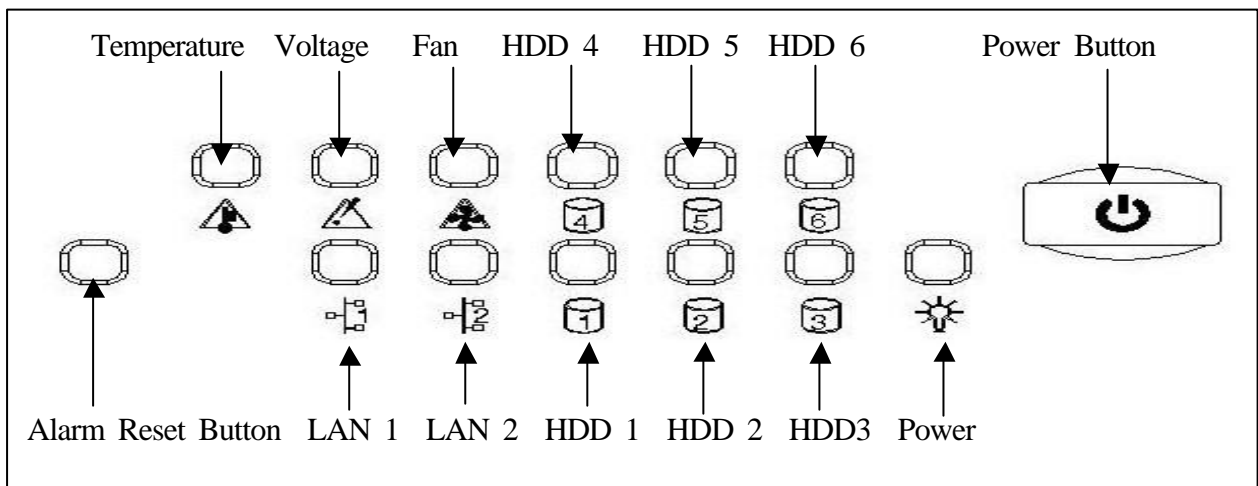

| | Indicator | Description |
|-------------|-----------|------------------|
| Voltage | Red | Voltage Failure |
| Temperature | Red | Over-Temperature |
| Fan | Red | Fan Failure |
| LAN 1 | Green | Active |
| LAN 2 | Green | Active |
| HDD 1 | Green | Active |
| HDD 2 | Green | Active |
| HDD 3 | Green | Active |
| HDD 4 | Green | Active |
| HDD 5 | Green | Active |
| HDD 6 | Green | Active |
| Power | Green | Power-on |
| | Orange | Standby |

1.5 Power supply Rear Panel

- **RS-100-RF**

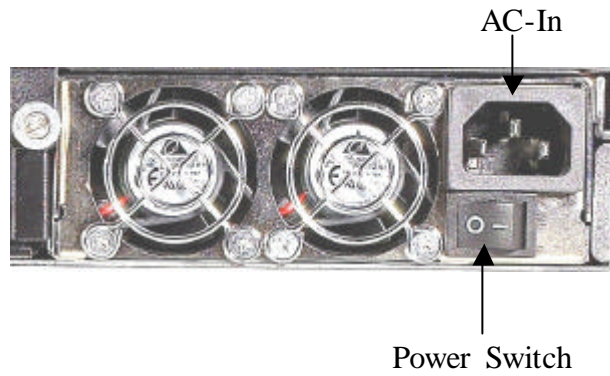

- **RS-200-RF**

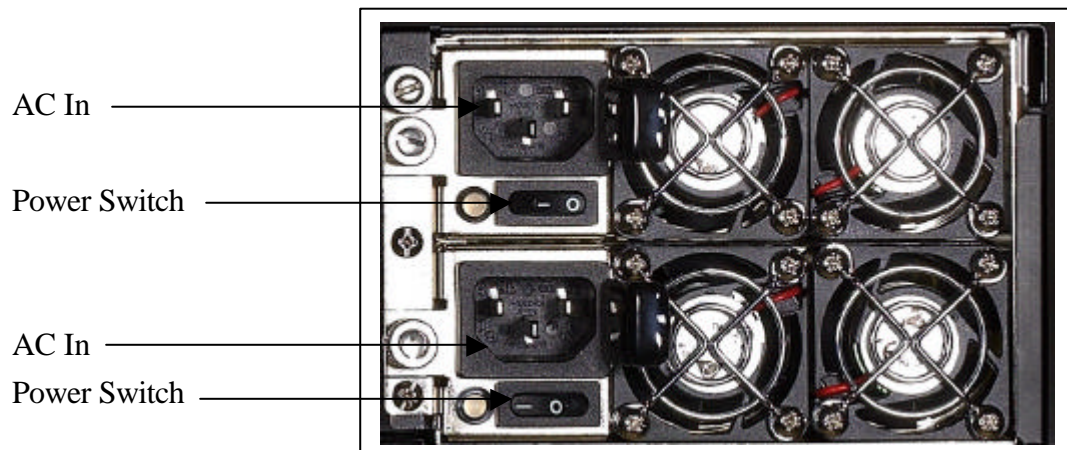

Redundant Power Supply

1.6 System Monitoring

Fan status monitoring and alarm: To prevent system from overheat and damage, the CPU fans and other system fans can be monitored for their speed and failure. The fans are set for their normal RPM range, and alarm threshold. If an alert is triggered, that means a failure status occurs. The system will show the signal by red light on the front panel and its buzzer sends out alarm sound. To press Alarm Reset button, system mutes, but Alarm LED still indicates red until the issue is solved.

Temperature monitoring and alert: To prevent system from overheat and damage, the server board supports processor thermal sensing and auto-protection. If an alert is triggered, that means a failure status occurs. The system will show the signal by red light on the front panel and its buzzer sends out alarm sound. To press Alarm Reset button, system mutes, but Alarm LED still indicates red until the issue is fixed.

Voltage monitoring and alert: System voltage levels are monitored to ensure stable current flows to critical components. If an alert is triggered, that means a failure status occurs. The system will show the signal on the front panel and its buzzer sends out alarm sound. To press Alarm Reset button, system mutes, but LED still indicates red until the issue is removed.

The system provides an optional SNMP software package that allows user monitoring remotely.

Chapter 2 Hardware Installation

2.1 Internal Outlook

2.1.1 Removing the Cover

1. Unscrew the screw at the rear side of upper cover.
2. Slide the upper cover backwards.
3. Lift up the upper cover.

Please refer to the figures below for illustration

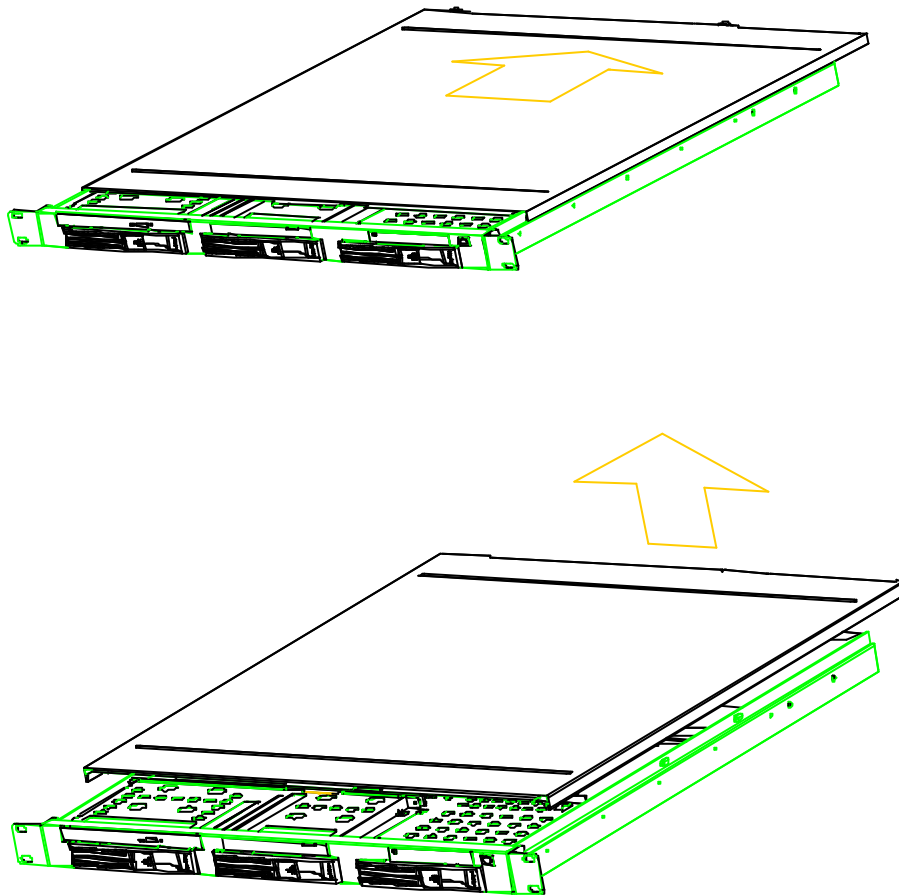

Upper cover removing

2.1.2 System Placement

- RS-100-RF

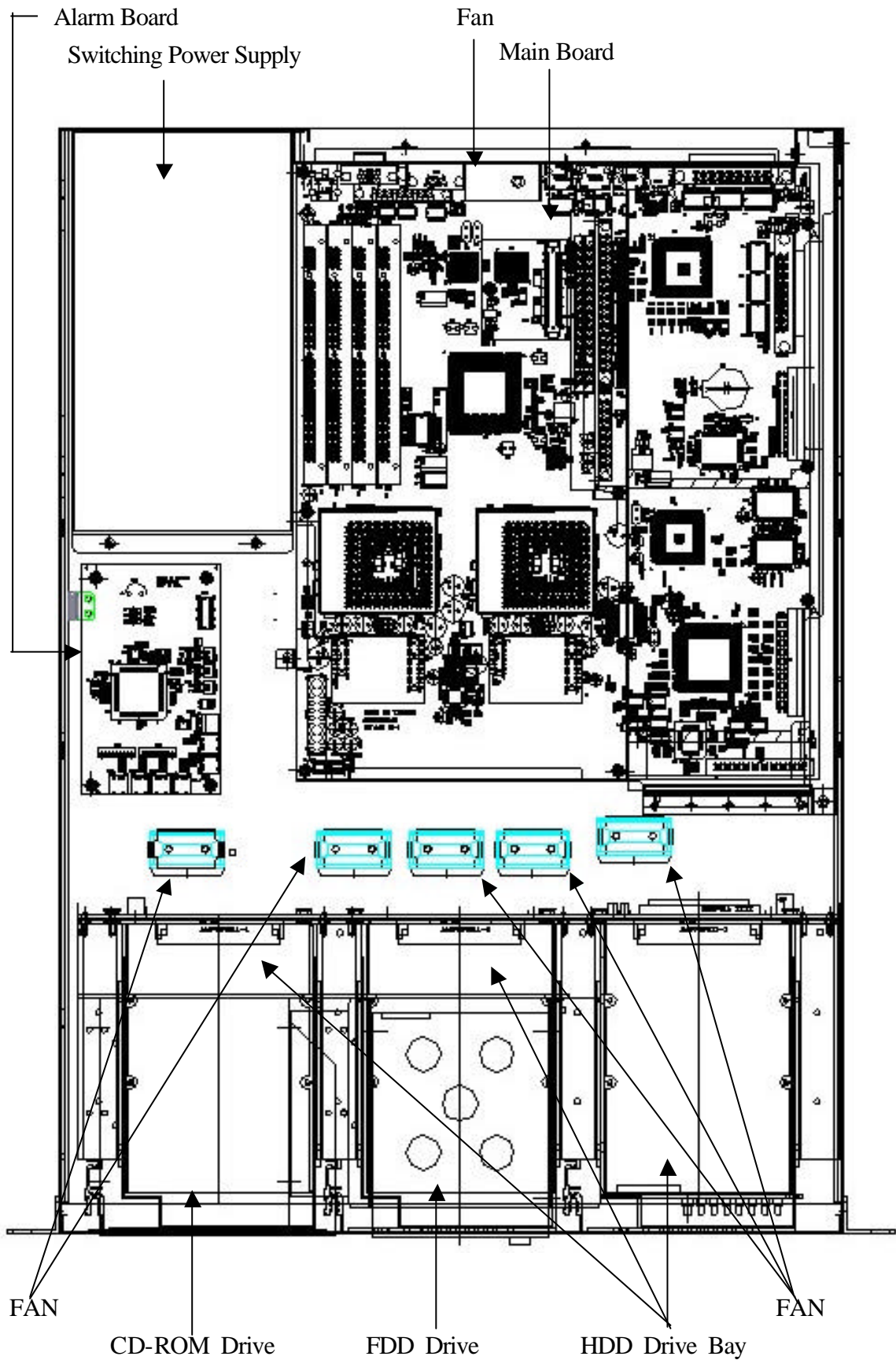

● RS-200-RF

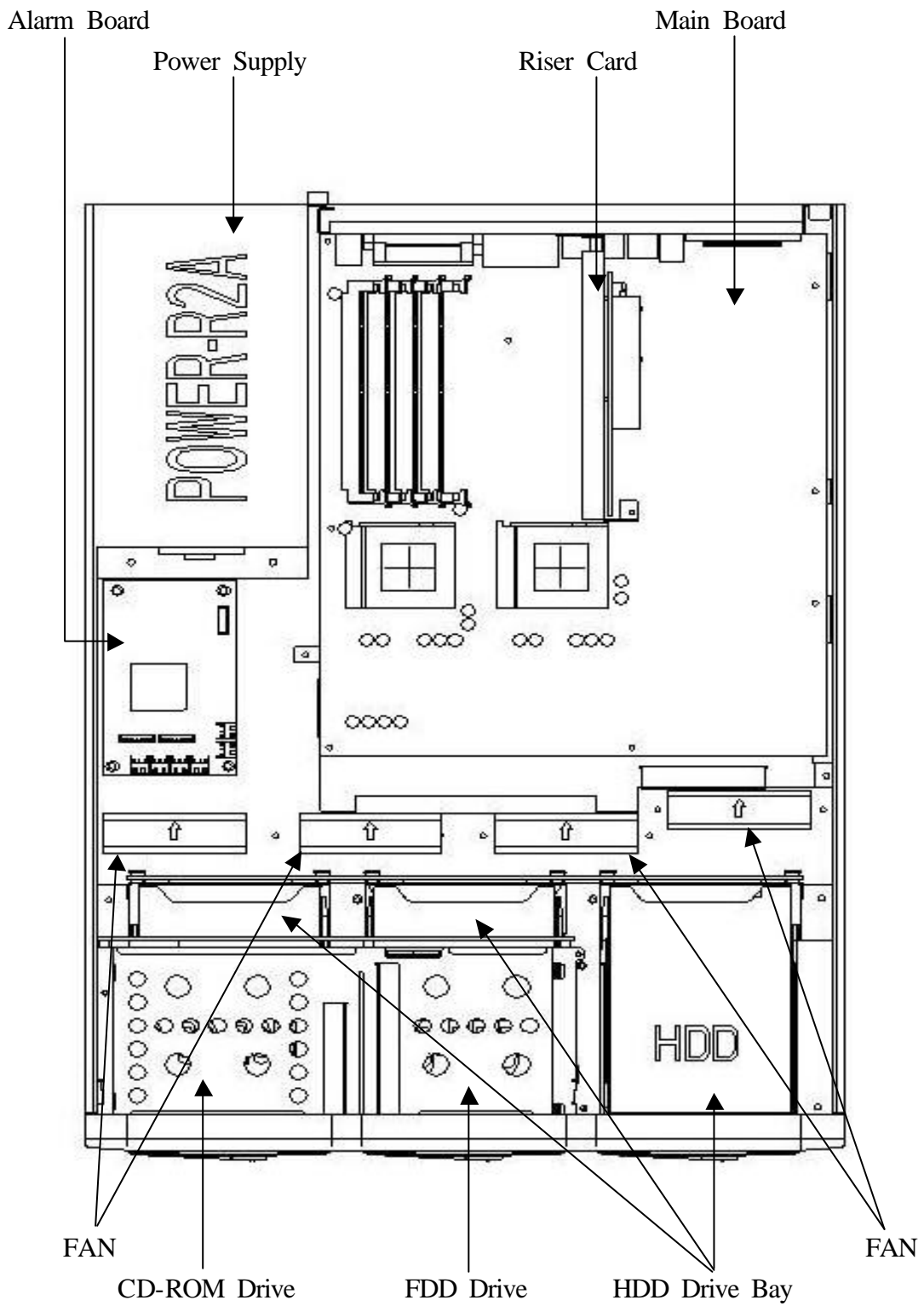

2.1.3 Main Board Placement

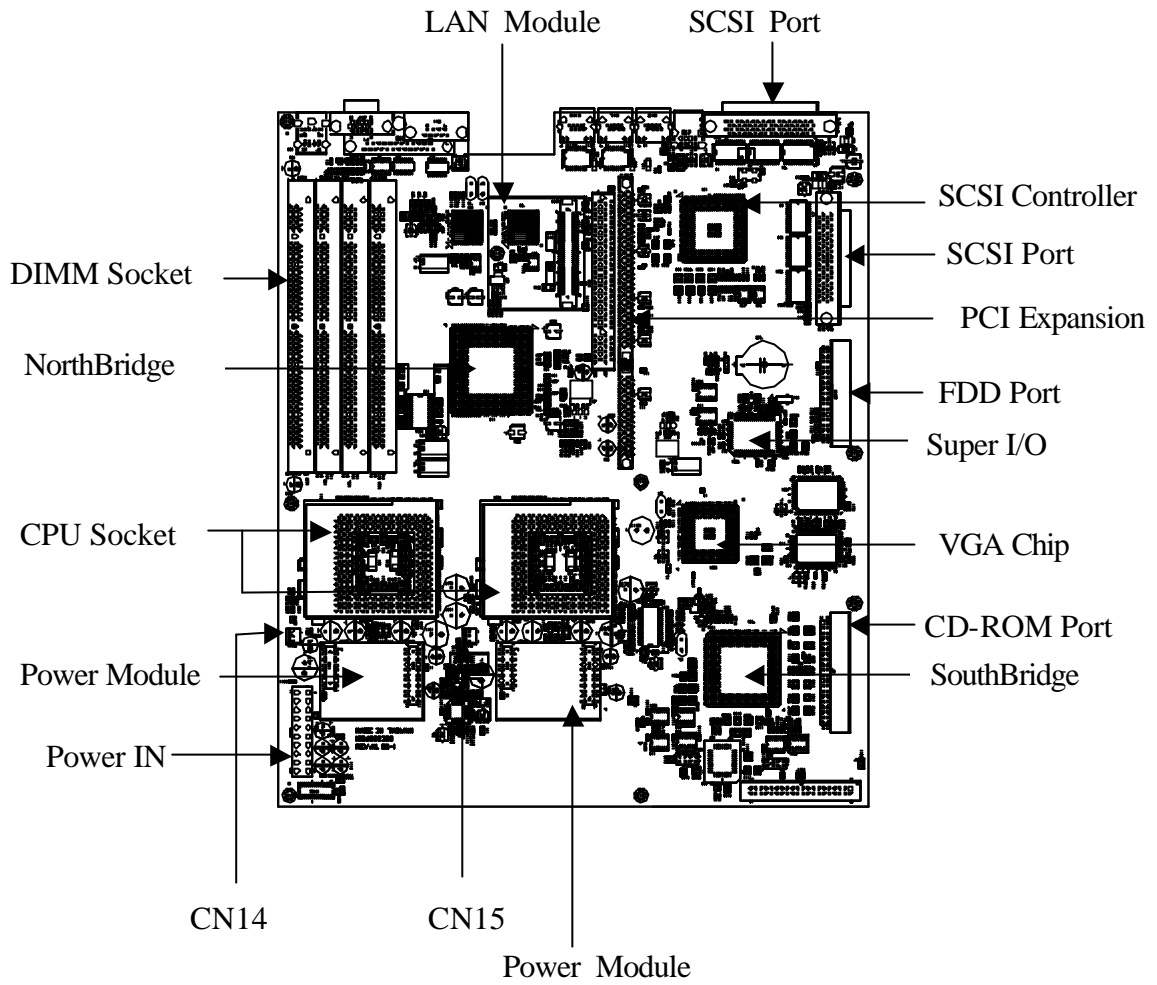

2.1.4 Alarm Board Placement

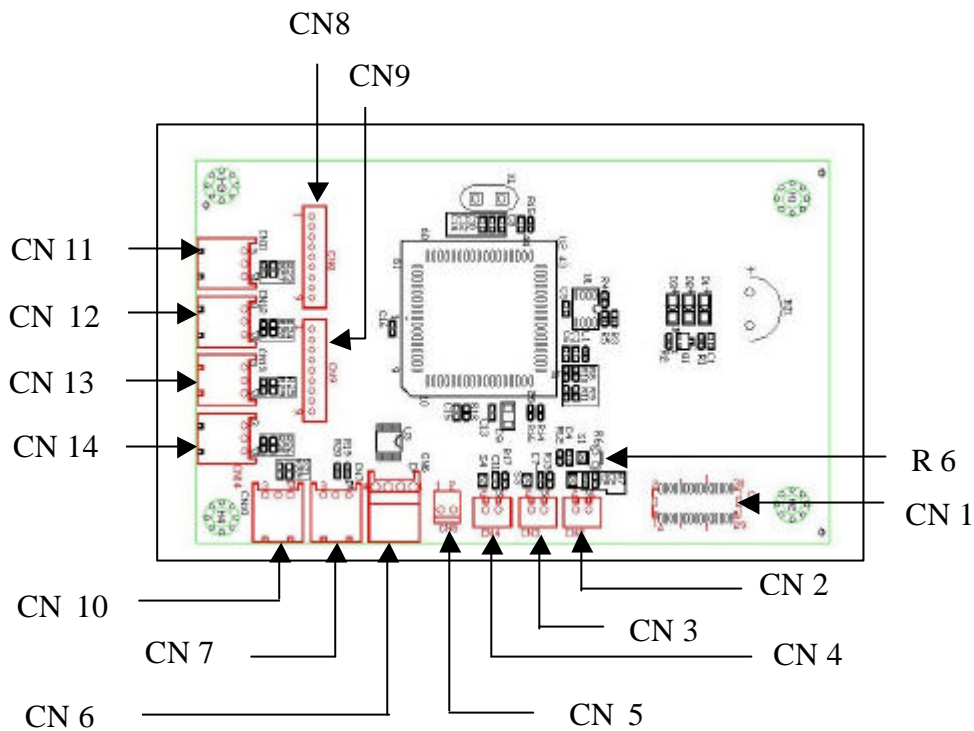

| No | Connector | Pin Count | Functions for RS-100-RF | Functions for RS-200-RF |
|----|-----------|-----------|-------------------------------|-------------------------------|
| 1 | CN1 | 30 | Board-to-board connect to M/B | Board-to-board connect to M/B |
| 2 | CN2 | 2 | Input Thermal Sensor 1 | Input Thermal Sensor 1 |
| 3 | CN3 | 2 | Reserved | Reserved |
| 4 | CN4 | 2 | Reserved | Reserved |
| 5 | CN5 | 2 | N/A | Redundant Power fail |
| 6 | CN6 | 4 | Power In | Power In |
| 7 | CN7 | 3 | Fan 3 Output | Fan 3 Output |
| 8 | CN8 | 9 | Status LED Output | Status LED Output |
| 9 | CN9 | 9 | N/A | Status LED Output |
| 10 | CN10 | 3 | Fan 2 Output | Fan 2 Output |
| 11 | CN11 | 3 | Reserved | Reserved |
| 12 | CN12 | 3 | Fan 4 Output | Reserved |
| 13 | CN13 | 3 | Fan 0 Output | Fan 0 Output |
| 14 | CN14 | 3 | Fan 1 Output | Fan 1 Output |
| 15 | R6 | 2 | Thermal Sensor 0 | Thermal Sensor 0 |

2.1.5 SCA-2 SCSI BackPlane Placement

- **RS-100-RF**

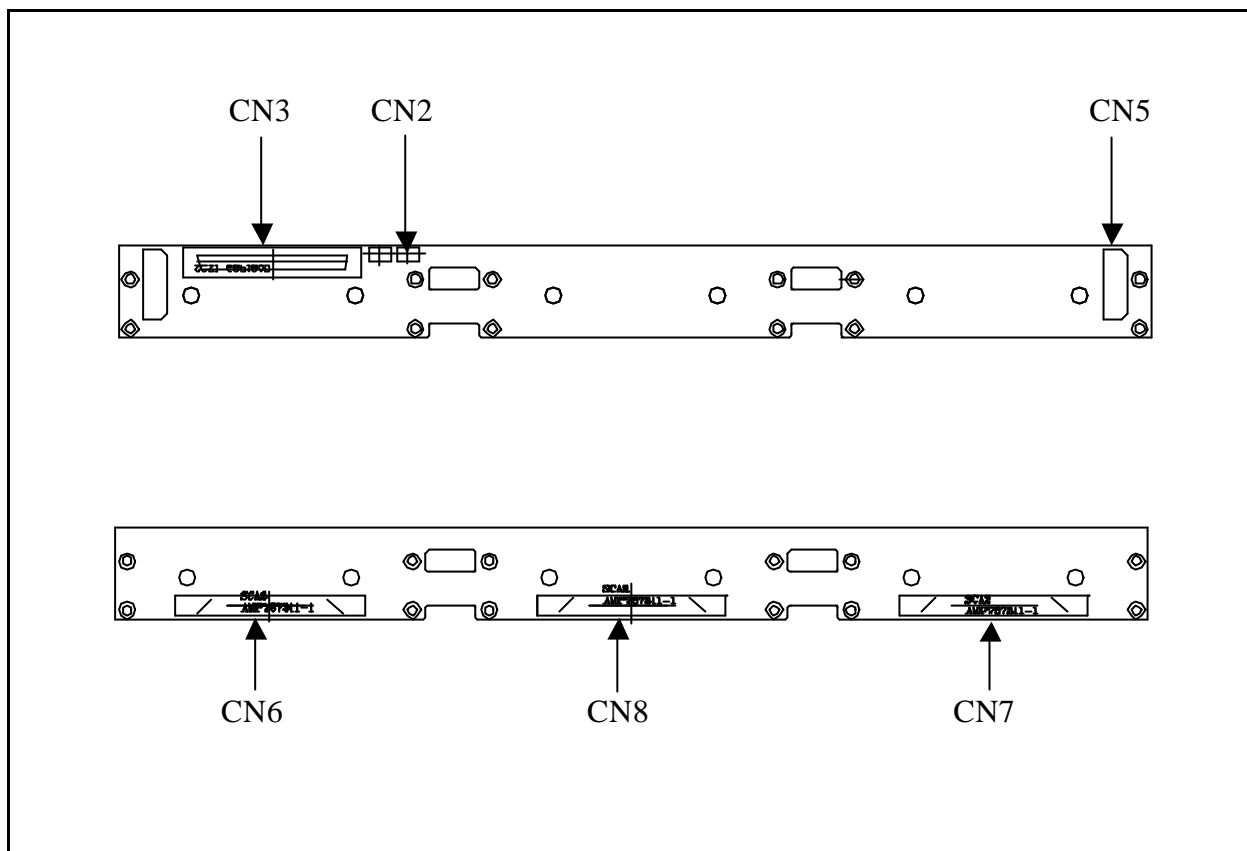

| Connector | Description |
|-----------|---------------------------------|
| CN2 | SCSI HDD Active Indicator |
| CN3 | 68-pin SCSI Connector (to Host) |
| CN5 | Power Connector |
| CN6 | SCA-2 SCSI HDD Connector (ID 3) |
| CN7 | SCA-2 SCSI HDD Connector (ID 1) |
| CN8 | SCA-2 SCSI HDD Connector (ID 2) |

- **RS-200-RF**

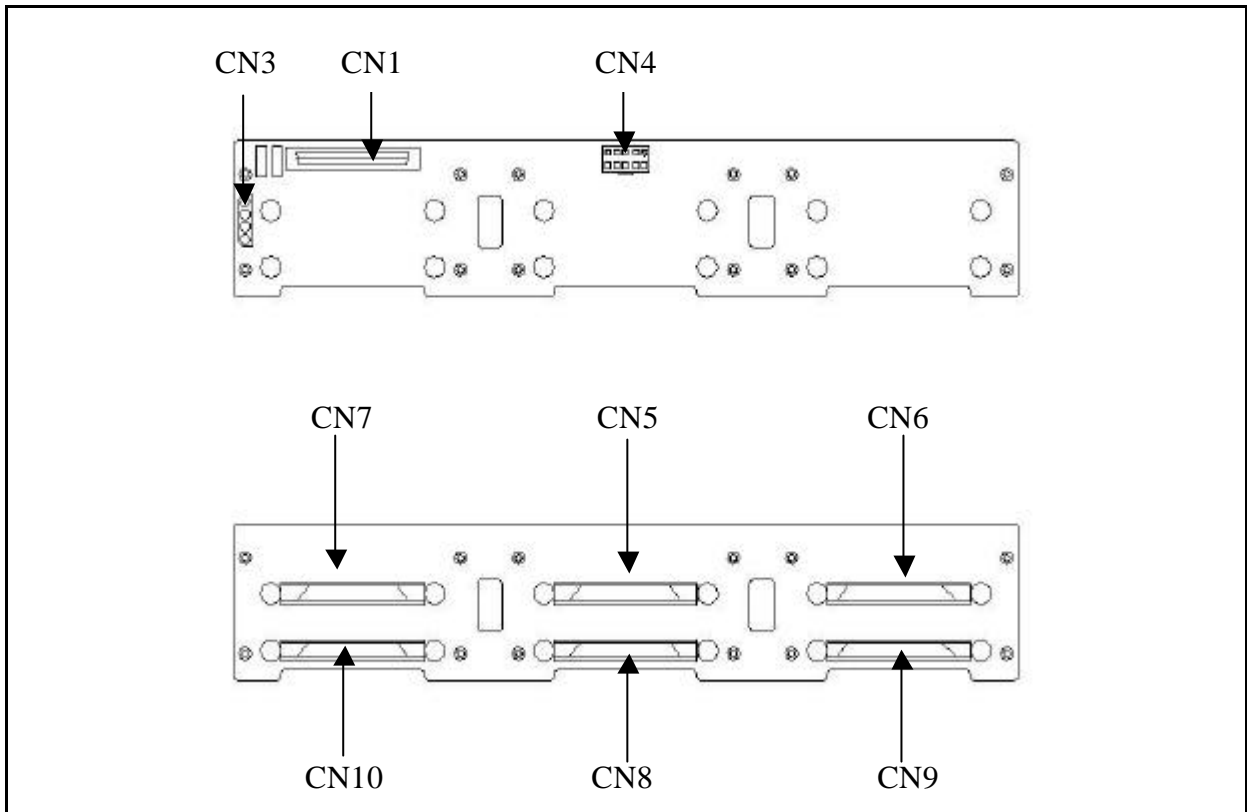

| Connector | Description |
|------------------|--|
| CN1 | 68-pin SCSI Connector (to Host) |
| CN3 | SCSI HDD Active Indicator |
| CN4 | Power Connector |
| CN5 | SCA-2 SCSI HDD Connector (ID 5) |
| CN6 | SCA-2 SCSI HDD Connector (ID 6) |
| CN7 | SCA-2 SCSI HDD Connector (ID 4) |
| CN8 | SCA-2 SCSI HDD Connector (ID 2) |
| CN9 | SCA-2 SCSI HDD Connector (ID 3) |
| CN10 | SCA-2 SCSI HDD Connector (ID 1) |

2.2 Installing CPU

The server has two Socket 370 CPU sockets that can accommodate Intel CPUs as noted in the server specification table. The server is designed to use a dual CPU configuration. The CPUs you install should be:

- The same type
- The same speed

To install the CPUs, first turn off your system, remove its cover and follow the following directions that come with the CPU. Always observe static electricity precautions when installing CPUs. The general procedure is:

1. Raise the CPUs' retaining lever to a position perpendicular to the socket up.
2. Orient the CPU to the socket correctly so that the pins match the receptacles.
3. Insert the CPU in the socket so that the pins fully insert.
4. Lower the retaining lever so that the CPU locks in place and latch the arm to the side of the socket.

Repeat this operation for the second CPU. If you will only install one CPU, you need to install it in the one CPU socket and you have to install an optional CPU terminator in another CPU socket. The procedure of installing CPU terminator is the same as CPU.

Warning: Without a fan or heat sink, a CPU will overheat and cause damage to both the CPU and the main board

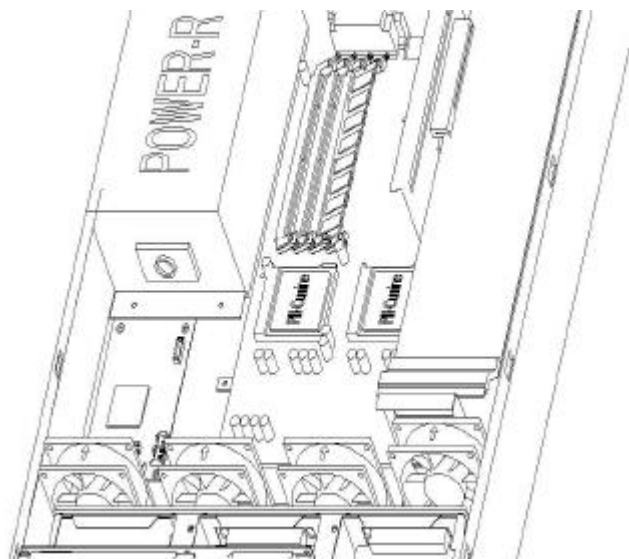

2.3 Installing CPU Cooler

The server comes with two high efficiency heatsink/ CPU coolers that sit on the top of an installed CPU and clip onto the CPU socket. After you install the CPUs, attach the CPU coolers as follows:

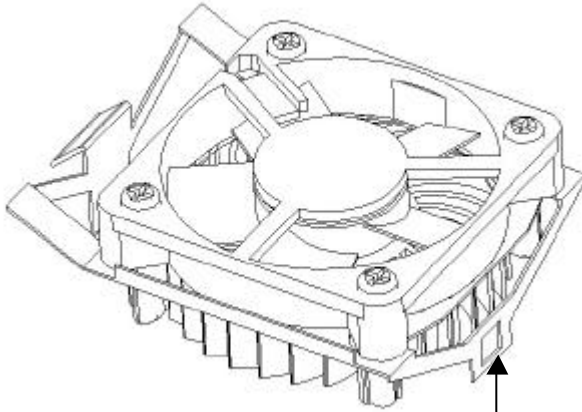

Place the clip to hold the protrusion on the side of CPU socket.

1. Place the cooler on the top of CPU with the spring clips oriented over the protrusions on the sides of the CPU socket.
2. Press the spring clips over the protrusions so that they snap in place.
3. Repeat steps 1-2 operations for the second CPU cooler on the second CPU socket.
4. Plug power connectors of CPU cooler into CN14 and CN15.

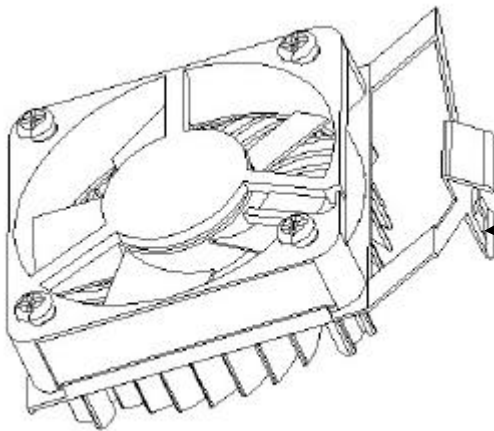

Place the clip to hold the protrusion on another side of CPU socket.

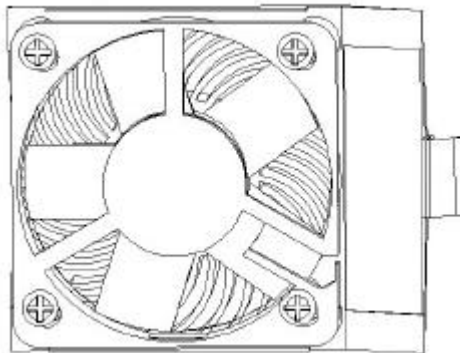

The Cooler Installed

2.4 Installing System Memory

The serverboard has four 168-pin DIMM sockets for 3.3V Registered PC-100/133-compliant SDRAM with ECC. The approved SDRAM module are showed in Appendix A. You can install any configuration up to the maximum specified in the server specification table. You can install any number or size of modules up to the maximum. Always observe static electricity precautions when installing memory.

To install DIMM modules do as follows:

1. Confirm the memory you plan to install meets the required specifications.
2. Press the socket retaining latches back out of the way.
3. Orient the module so that the edge connector sections correctly match the socket sections.
4. Holding the module to the socket, place it in the socket so that the edge connectors insert slightly in the socket. Make sure they match.
5. Press the module into the socket so that it seats firmly in place and the retaining latches rotate upwards and seat themselves in the notches on the side of the module.

Repeat this operation for the rest of modules you will install.

Note: Serverworks III LE chipset can support system memory size up to 4GB, but it depends on OS support. It means if OS only supports system memory up to 2GB, then the system with this OS installed also supports system memory up to 2GB.

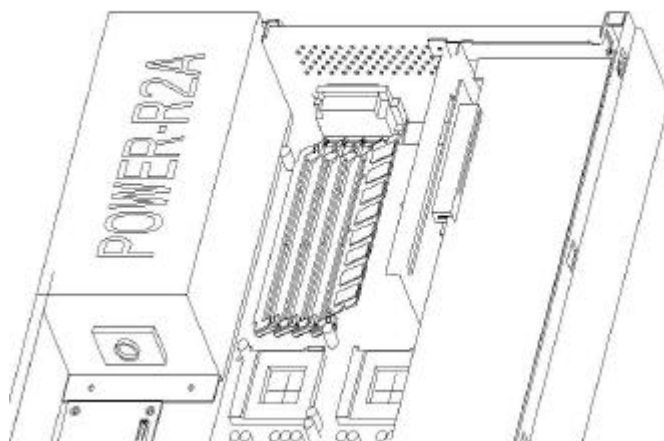

Prepare to insert SDRAM into DIMM socket

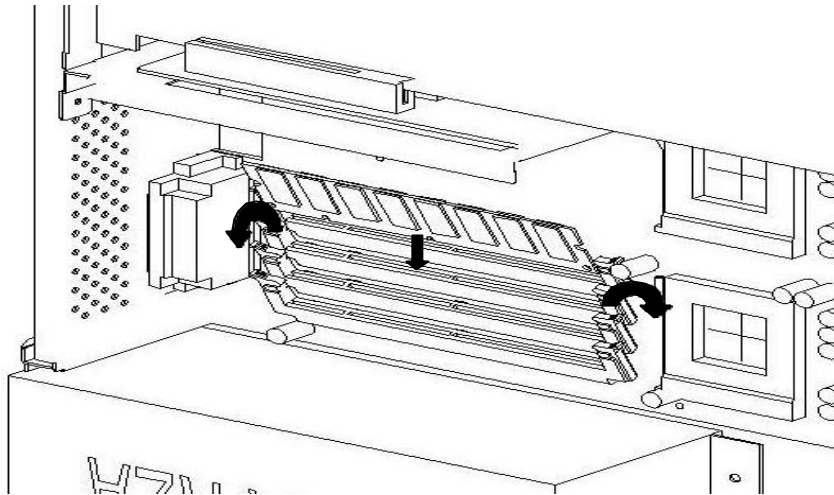

1. Flip the levers on either end of the DIMM socket to the open position.
2. Line up the notches on the memory module with the tabs in the DIMM socket.
3. Firmly, but carefully, press the DIMM into place.
4. The levers will automatically close when the DIMM is properly seated in the socket.

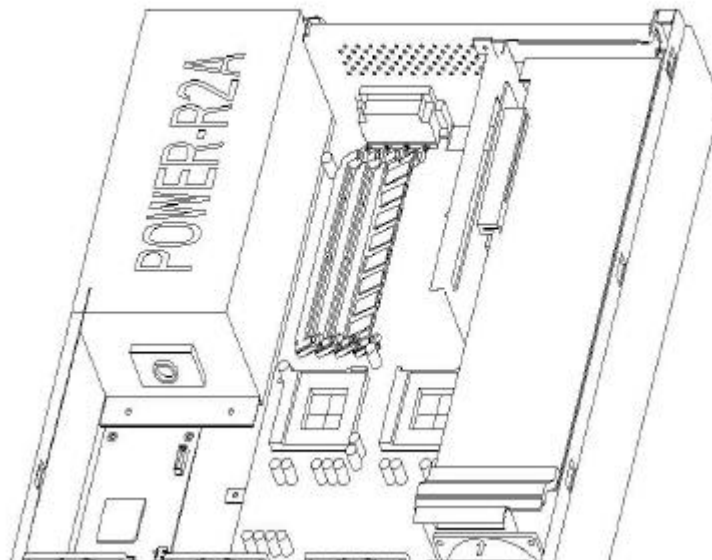

SDRAM Module installed in DIMM socket

2.5 Installing Add-on Cards

- **RS-100-RF**

If you need to install an expansion card in the PCI expansion slot, follow the card installation directions. You can install one PCI expansion card. The slot is mounted horizontally on a preinstalled riser card and there is room for a full sized expansion card

- **RS-200-RF**

There are three expansion slots on the preinstalled riser card. It allows user to install up to 3 64-bit/33MHz PCI add-on cards in the expansion slots, but if user likes to install 64-bit/66MHz PCI add-on card, the riser only accepts one 64-bit/33Mhz add-on card due to chipset limitation.

The detailed installation procedure is stated as follows:

Unscrew the screw on the rear to fix the bracket of the riser card

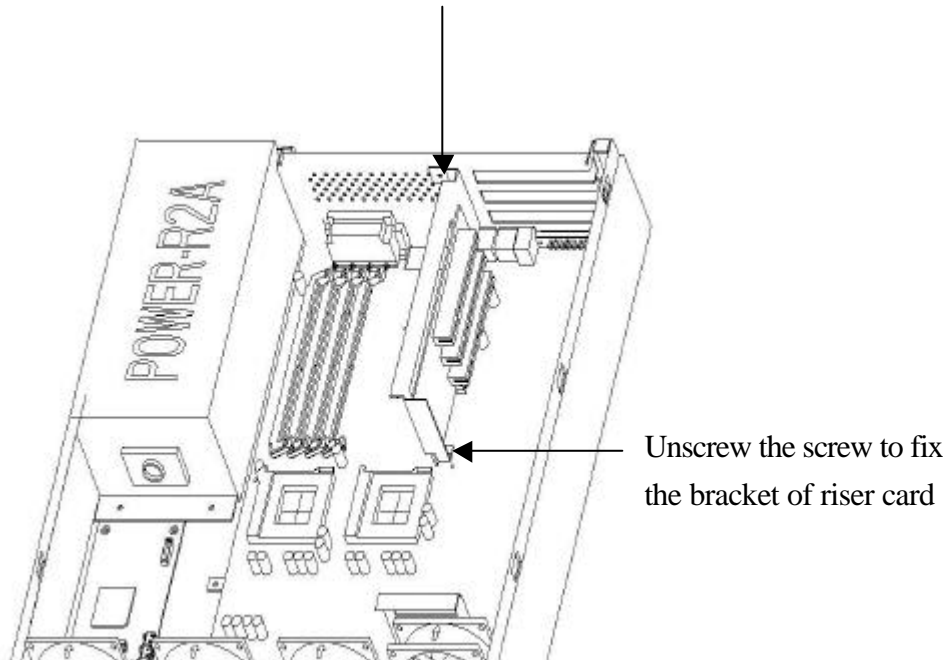

1. Unscrew the screws fixing the bracket of the Riser Card
2. Pull up the Riser Card

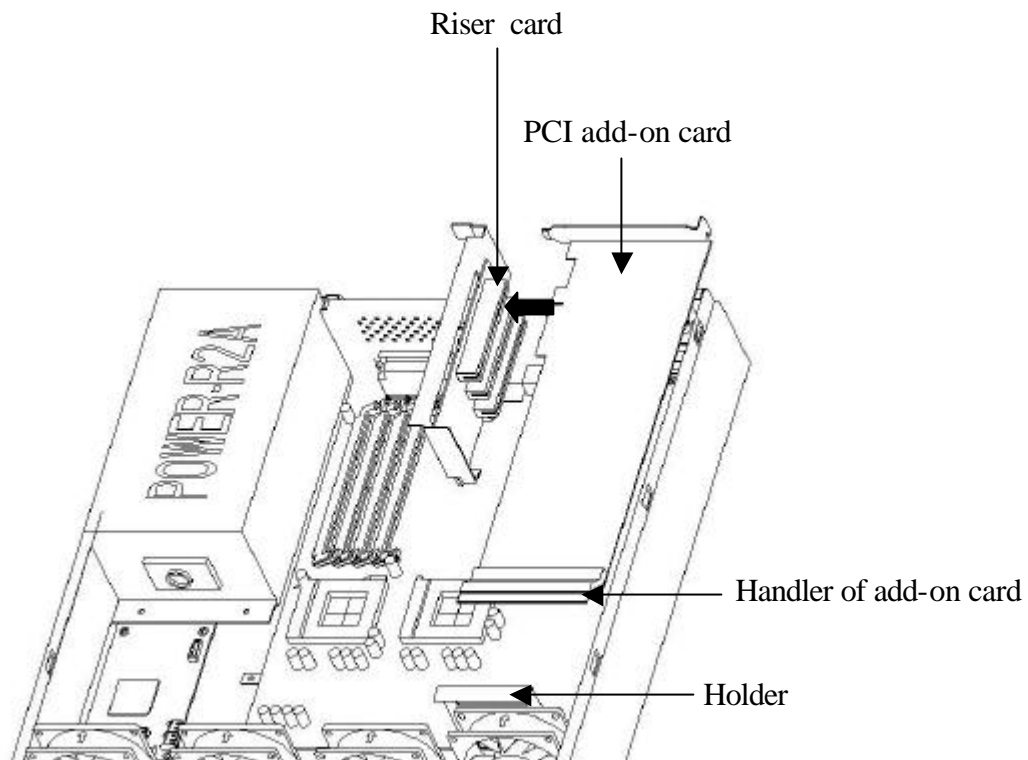

Plug the Add-on card horizontally into PCI slot on the Riser Card.

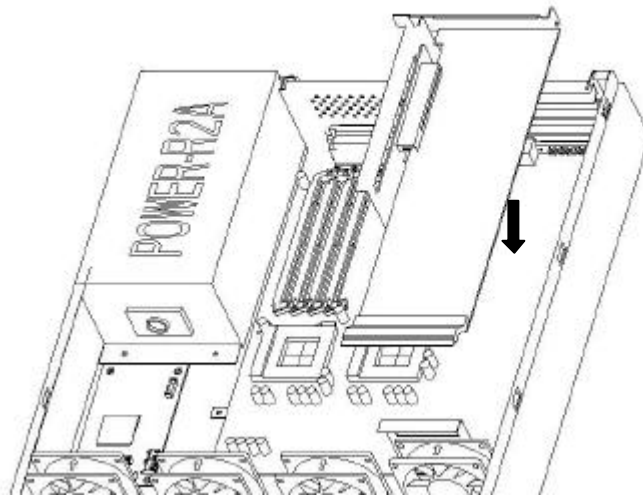

1. Put down the assembled expansion cards.
2. Put the handler of full size add-on card into the holder

Screw the screw to fasten the bracket of the riser card

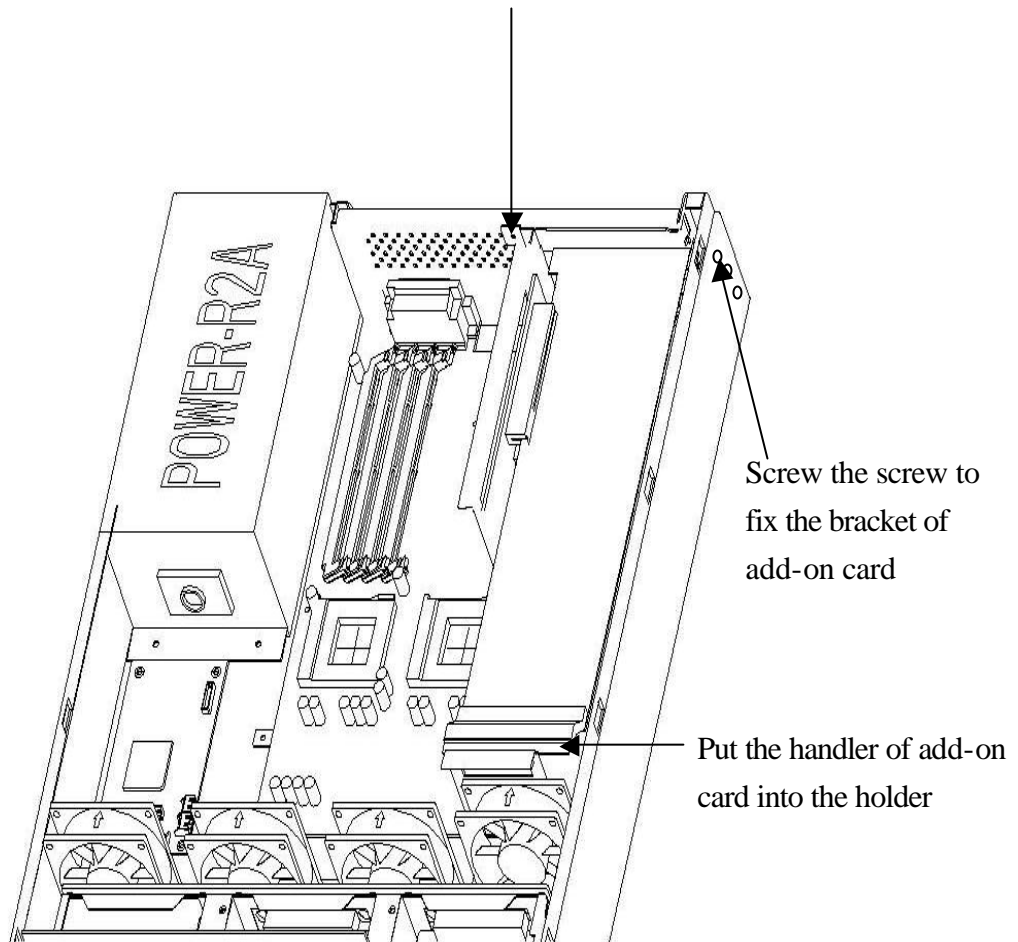

1. Screw the screws to fasten the riser card
2. Screw the screw to fasten add-on card

2.6 Adding Disk Drives

The RS-100/200-RF has preinstalled three/six hard disk drive bays, one slim-type CD-ROM (which is set in the master mode only) and one slim-type floppy disk drive. The RS-100/200-RF provides one SCA-2 backplane and can support three/six hot-swap hard disk drives.

Please notice that if the hard disk drives used in the RS-100/200-RF shall be 3.5", 1" height SCSI hard disk drives with 80-pin SCA-2 connectors.

In order to install the hard disk drives in the chassis, please follow the procedures below.

1. Unfasten the dummy HDD trays from the hard disk rack.
2. Put the hard disk drives in the hard racks and fasten them with screws.
3. Slide the hard disk racks into the drive bay.

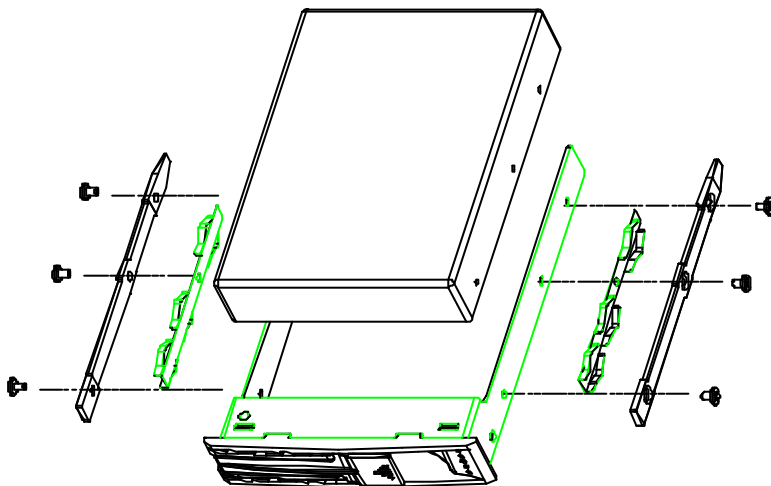

Installing a hard disk drive in the hard disk rack

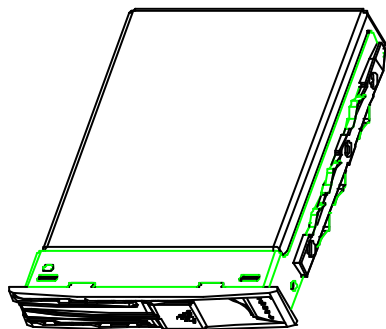

Hard disk assembled

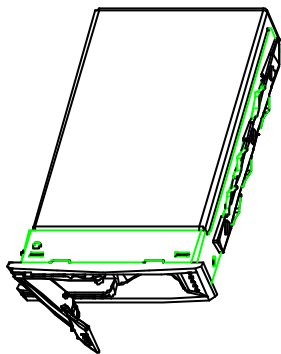

Opening the handler of hard drive cage

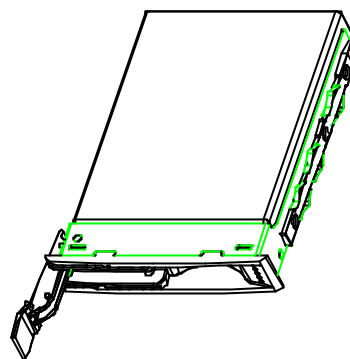

The handler of hard drive bay fully open

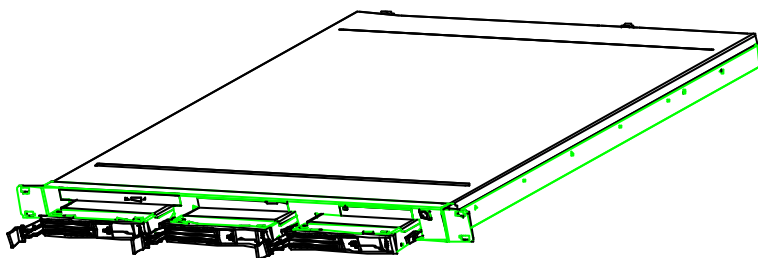

Putting the cages of the hard drive into the hard drive bays

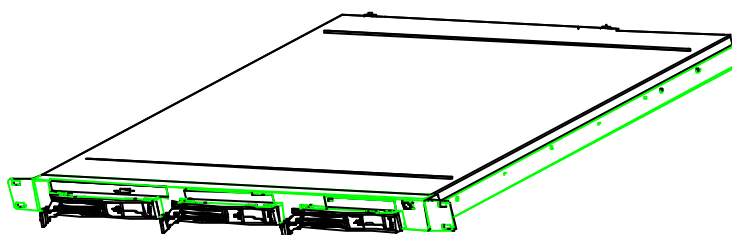

Closing the latches

2.7 Install LAN Module

The server provides an optional LAN module for the third 10/100Mbps LAN. You can buy the LAN module from your dealer near you. Please plug the third LAN module into the 80-pin connector located on Main Board and fasten it by M3 screw. Please refer to 2.1.3 Main Board Placement for LAN module location.

The system is equipped with 3 high-performance 32-bit PCI-bus Ethernet interfaces, which are fully compliant with IEEE 802.3/u 10/100Mbps CSMA/CD standards. They are supported by all major network operating systems. Three onboard RJ 45 jacks provide convenient 10/100Base-T RJ-45 operations.

Chapter 3 BIOS Setup

Award BIOS ROM has a built-in Setup program that allows users to modify the basic system configuration. This type of information is stored in battery-backed RAM (CMOS RAM), so that it retains the Setup information when the power is turned off.

You should be able to use the BIOS optimized default settings as they come from the factory. If you want to check or alter BIOS settings, run the CMOS Setup Utility by pressing the “**Del**” key command during the POST. If you think the settings need to be refreshed, run the Setup Utility, choose the “**Load Optimized Defaults** “ option from the main menu, save and reboot.

3.1 Function Keys

The Function Keys are located at the bottom of CMOS setup screen. The keys allow users to navigate then main setup menu. The following table lists describe their functions.

| Key | Function Description |
|--------------|--|
| Esc | Jump to Exit menu or return to the main menu from sub-menu |
| or | Move the cursor to the up or down between fields |
| or | Select the menu item to the left or the right |
| Enter | Select menu item |
| F10 | Save & Exit Setup |

The Function keys of **sub-menu** are described as below:

| Key | Function Description |
|--------------|---|
| Esc | Jump to Exit menu or return to the main menu from sub-menu |
| or | Move the cursor to the up or down between fields |
| or | Select the menu item to the left or the right |
| PU/PD | Modify the value or setting |
| +/- | Modify the value or setting |
| Enter | Select the menu item |
| F1 | Display the General Help screen from anywhere in the BIOS Setup |
| F5 | Load Previous Values |
| F7 | Load Optimized Defaults |
| F10 | Save the setting |

3.2 Main Menu

When the Setup program is accessed, the following screen appears. Move arrow keys to appropriate place you will setup and press “**Enter**” for selection.



3.2.1 Standard CMOS Features

Choose the “**Standard CMOS Features**” option from main menu. The “**Standard CMOS Features**” allows users to configure system components such as date, time, hard disk drive and floppy drive showed in the screen below:

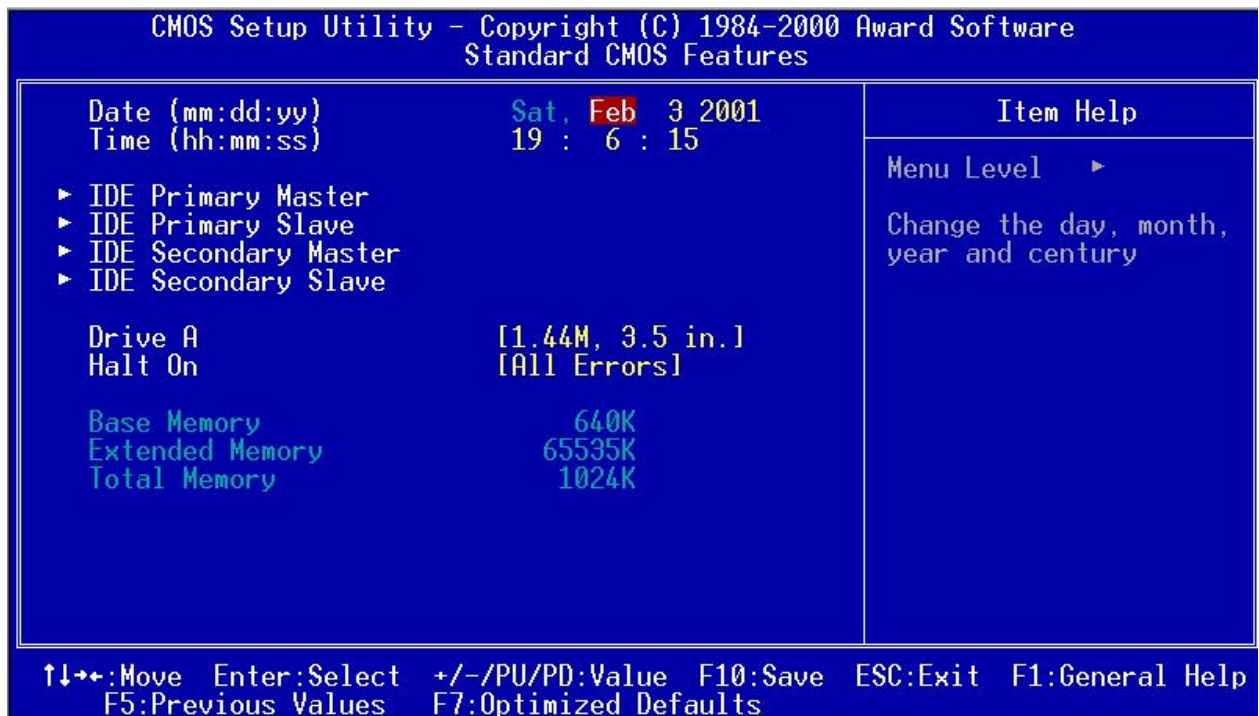

Date (mm:dd:yy): Set system date you specify. The format is month, day and year. Move to proper place by arrow keys in order to modify the values by Page Up/+ Key or Page Down/ - Key.

Time (hh:mm:ss): change internal clock.

IDE Primary Master: Move the highlight to the option “**IDE Primary Master**” and enter to get the following screen.

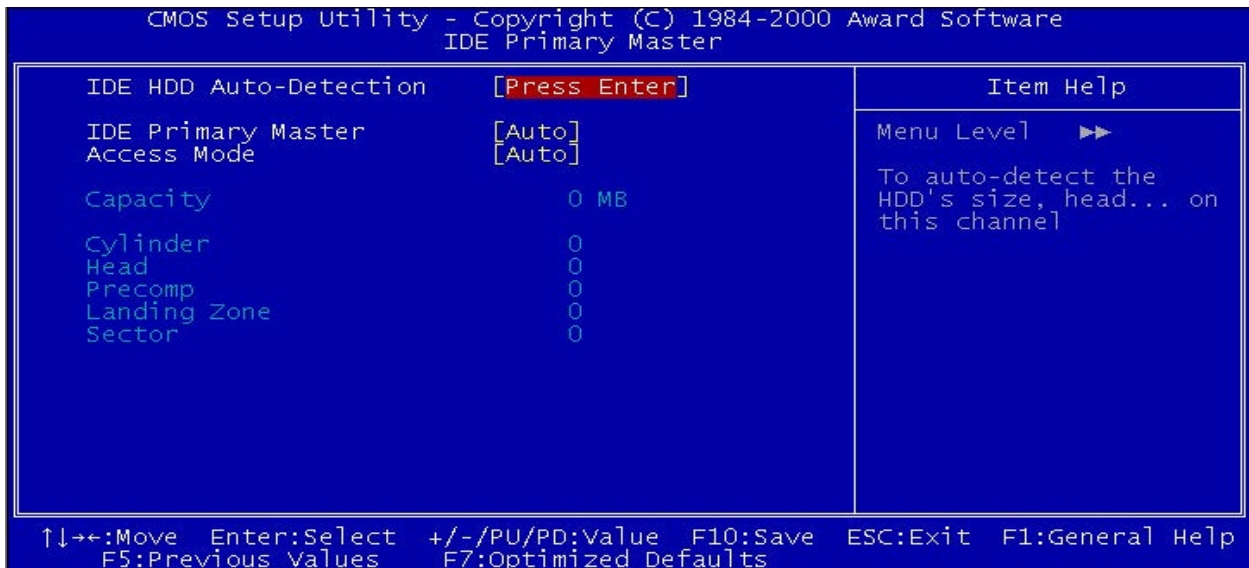

IDE HDD Auto-Detection: To auto-detect the capacity, cylinder, head and sector of HDD

IDE Primary Master: [Auto/Manual/None]

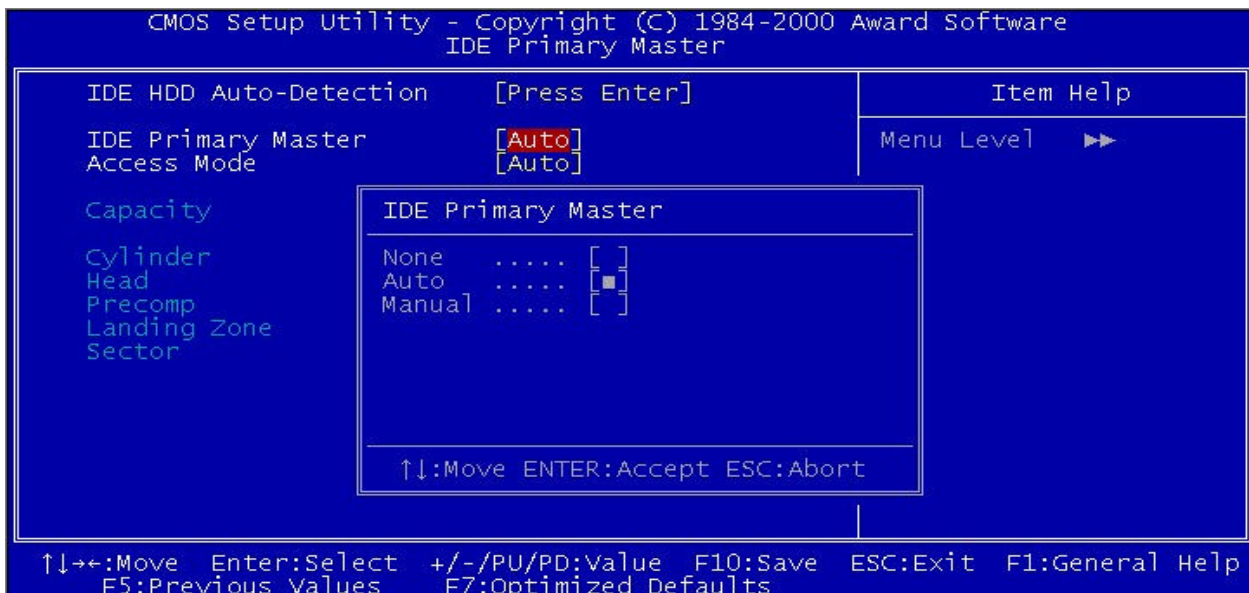

Access Mode: **[Auto/Large/LBA/CHS]**

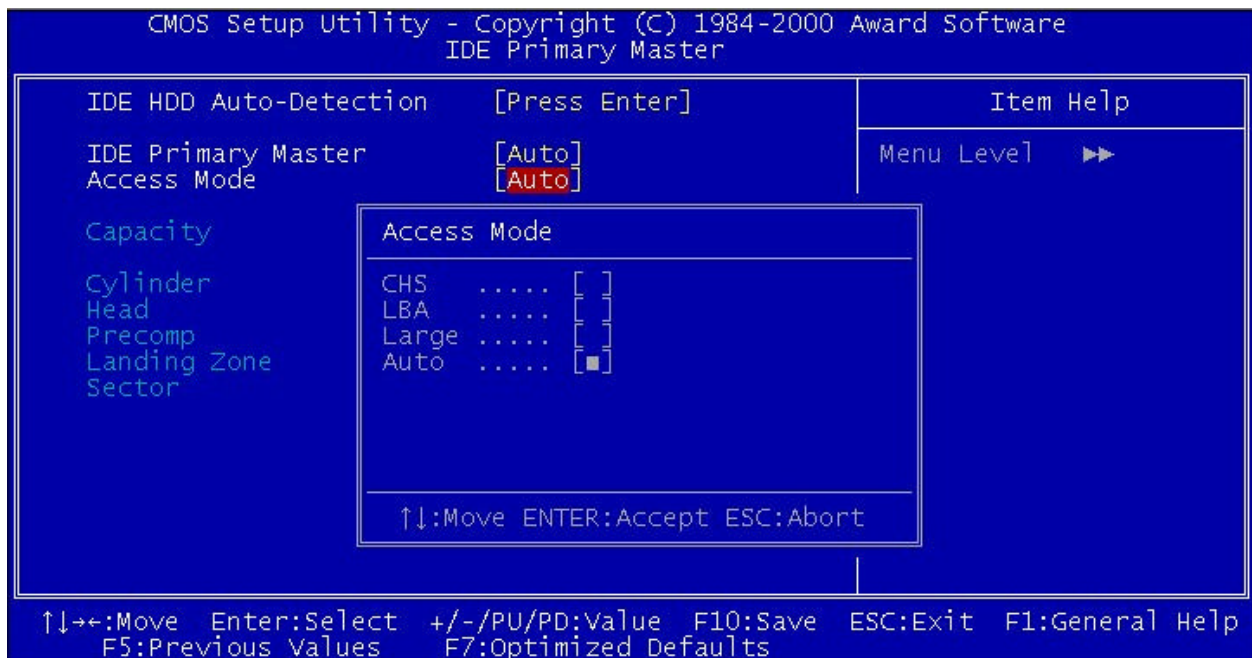

IDE Primary Slave: Choose the option then get the following three items.

IDE HDD Auto-Detection: To auto-detect the capacity, cylinder, head and sector of HDD

IDE Primary Slave: **[Auto/Manual/None]**

Access Mode: **[Auto/Large/LBA/CHS]**

IDE Secondary Master: Choose the option then get the following three items.

IDE HDD Auto-Detection: To auto-detect the capacity, cylinder, head and sector of HDD

IDE Secondary Master: **[Auto/Manual/None]**

Access Mode: **[Auto/Large/LBA/CHS]**

IDE Secondary Slave: Choose the option then get the following three items.

IDE HDD Auto-Detection: To auto-detect the capacity, cylinder, head and sector of HDD

IDE Secondary Slave: **[Auto/Manual/None]**

Access Mode: **[Auto/Large/LBA/CHS]**

Drive A: Set the type of floppy drive installed by Page Up Key and Page Down.

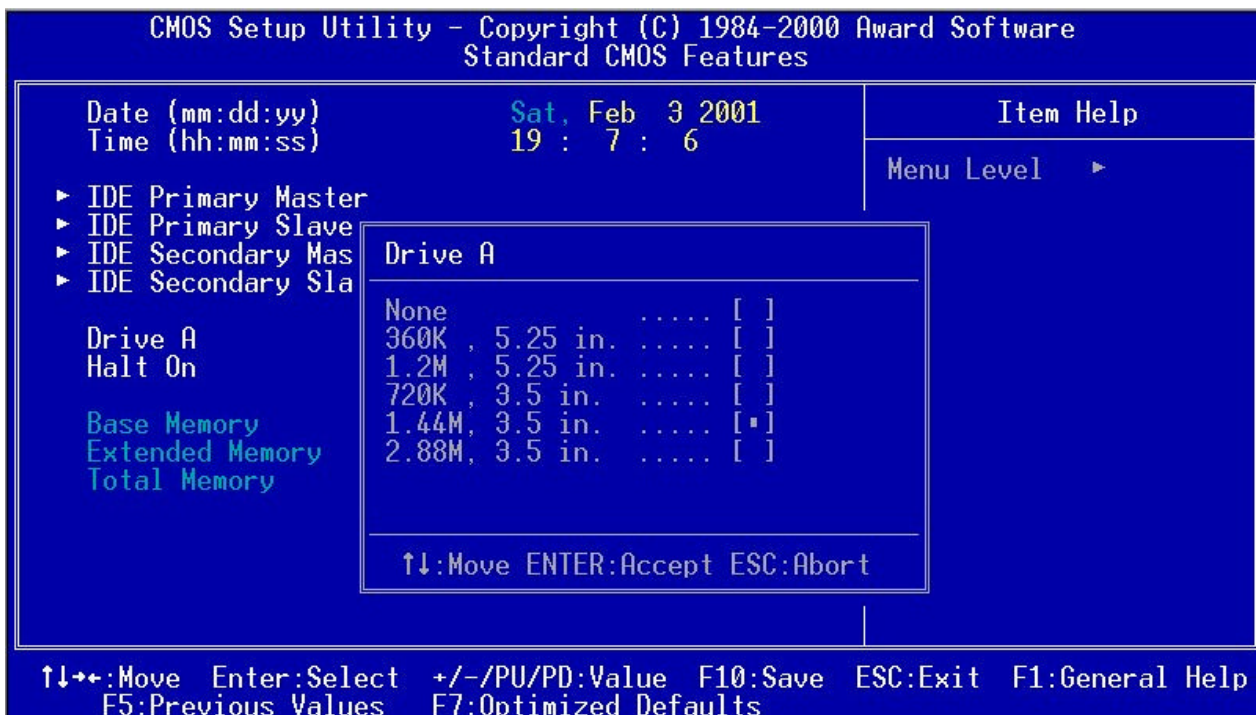

Halt On: Set system halt on when specified item occurs. The selection items are showed in the following screen.

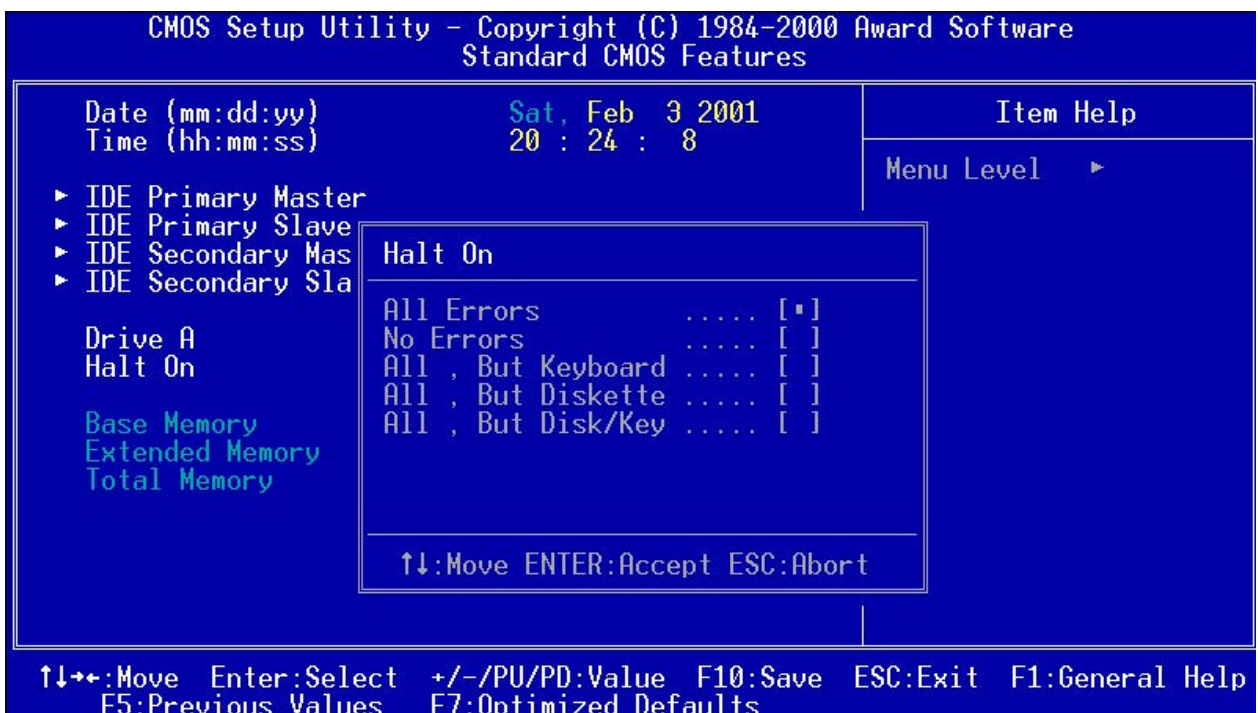

3.2.2 Advanced BIOS Features

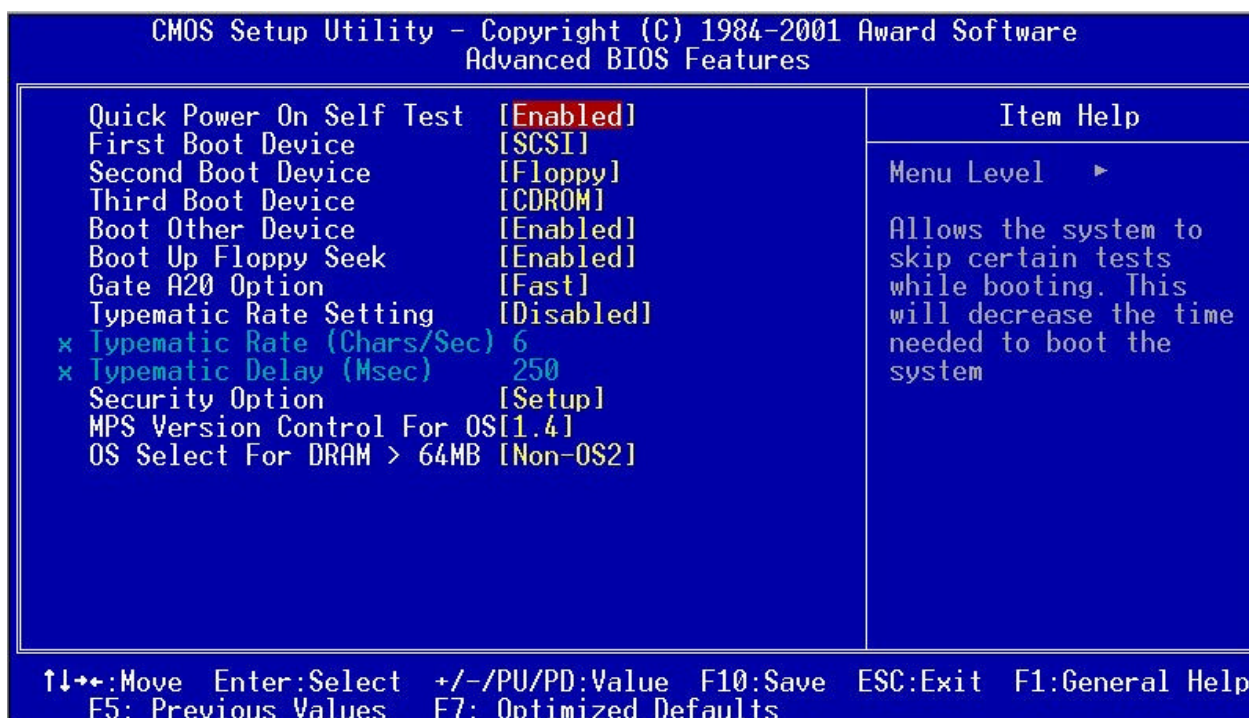

Quick Power On Self Test (POST) [Enabled/Disabled]: Allows the system to skip certain tests while booting. This will decrease the time needed to boot the system.

First Boot Device [Floppy/SCSI/CD-ROM/HDD/LAN/Disabled]: Select your boot device priority

Second Boot Device [Floppy/SCSI/CD-ROM/HDD/LAN/Disabled]: Select your boot device priority

Third Boot Device [Floppy/SCSI/CD-ROM/HDD/LAN/Disabled]: Select your boot device priority

Boot Other Device [Enabled/Disabled]: Select your boot device priority

Boot Up Floppy Seek [Enabled/Disabled]: **Enable-**During POST, BIOS will determine if the floppy disk drive installed is 40 or 80 tracks. A 360 KB type drive is 40 tracks; while 720 KB, 1.2 MB, and 1.44 MB type drives are all 80 tracks. **Disable-** BIOS will not search for the floppy drive type by track number.

Gate A20 Option [Fast/Normal]: **Fast-** let chipset control Gate A20; **Normal-**a pin in keyboard controller controls Gate A20. Default is set “**Fast**”.

Typematic Rate Setting [Enabled/Disabled]: Keystrokes repeat at a rate determined by keyboard controller. When enabled, the typematic rate and typematic delay can be selected.

Typematic Rate (Chars/Sec): BIOS accepts the following input values (characters/second) for typematic rate: 6, 8, 10, 12, 15, 20, 24 and 30.

Typematic Delay (msec): Typematic delay is the time interval between the appearances of two consecutive characters, when holding down a key. The input values for this category are: 250, 500, 750, 1000 (msec).

Security Option [System/Setup]: The setting determines whether the system will boot up if the password is denied. Access to Setup is, however, always limited. **System-** The system will not boot, and access to Setup will be denied if the correct password is not entered at the prompt. **Setup-** The system will boot, but access to Setup will be denied if the correct password is not entered at the prompt.

MPS Version Control For OS [1.4/ 1.1]

OS/2 selection for DRAM > 64MB[Non-OS2/ OS2]: Select OS2 if you are running OS/2 Operating System with greater than 64MB of RAM on the system.

3.2.3 Integrated Peripheral

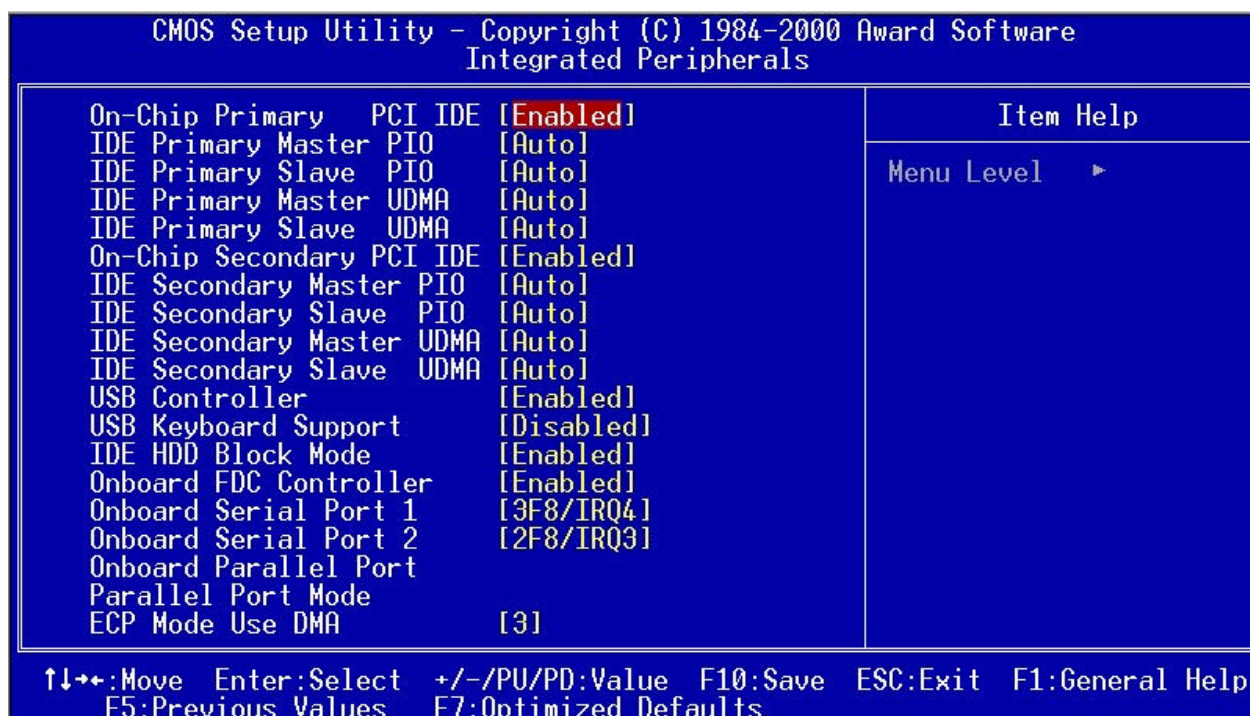

On-Chip Primary PCI IDE [Enabled/Disabled]: The system provides an onboard on-chipset PCI IDE controller that supports Dual Channel IDE. A maximum of 4 IDE devices can be supported. If user installed the Off-Board PCI IDE controller, the user must choose which channels will be disabled. This will depend on which channel will be used for the Off-Board PCI add-on card.

IDE Primary Master/Slave PIO [Auto/Mode0/Mode 1-4]

Each channel has both a master and a slave, making four IDE devices possible. Because each IDE device may have a different Mode timing (0,1,2,3,4), it is necessary for these to be independent. The default setting “Auto” will allow auto-detection to ensure optimal performance.

IDE Primary Master/Slave UDMA [Auto/Disabled]

On-Chip Secondary PCI IDE [Enabled/Disabled]

IDE Secondary Master/Slave PIO [Auto/Mode0/Mode 1-4]

IDE Secondary Master/Slave UDMA [Auto/Disabled]

USB Controller [Enabled/Disabled]

USB Keyboard Support [Enabled/Disabled]: Choosing “Enabled” will allow the system to use USB keyboard without device driver.

IDE HDD Block Mode [Enabled/Disabled]: **Enabled** allows the Block mode access for the IDE HDD

Onboard FDC Controller [Enabled/Disabled]: The system has an on-board Super I/O chip with a FDD controller that supports a FDD Drive for 360K/ 720K/1.2M/1.44M. Choose “**Enabled**” to use the on-board FDD controller for accessing the FDD. Otherwise choose ”**Disabled**” to use the off-board FDD controller.

Onboard Serial Port 1[Auto/Disable/(3F8/IRQ4)/(2F8/IRQ3)/(3E8/IRQ4)/(2E8/IRQ3)]

Onboard Serial Port 2 [Auto/Disable/(3F8/IRQ4)/(2F8/IRQ3)/(3E8/IRQ4)/(2E8/IRQ3)]

The system has an On-board Super I/O chipset with 2 serial ports. The On-board serial ports can be selected as:

Auto

Disable

3F8/IRQ4 COM 1 uses IRQ4

2F8/IRQ3 COM 2 uses IRQ3 (Reserved for Internal Alarm Board)

3E8/IRQ4 COM 3 uses IRQ4

2E8/IRQ3 COM 4 uses IRQ3

ECP Mode Use DMA: In ECP Mode Use DMA, you can select DMA channel 1 or DMA channel 3. Leave this field on the default setting.

3.2.4 PnP/ PCI Configurations

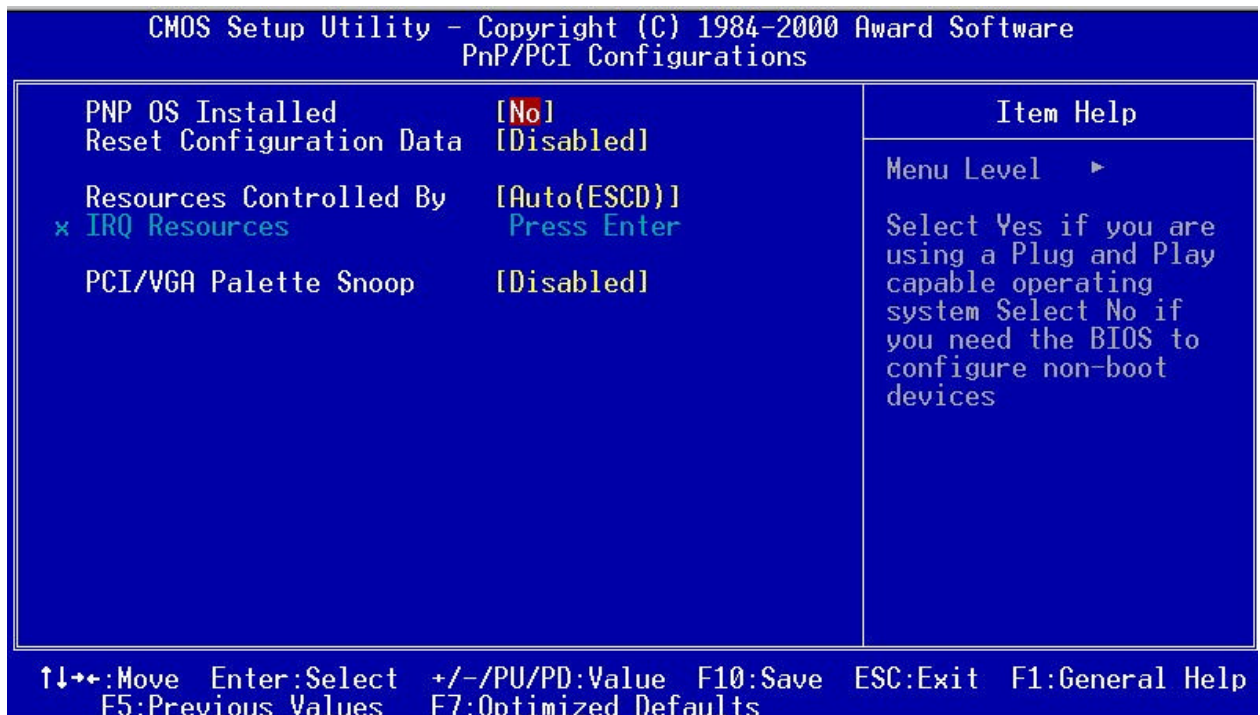

PnP OS Installed [Yes/No]: Select “Yes” if you are using a Plug and Play capable operating system. Select “No” if you need the BIOS to configure non-boot devices.

Reset Configuration Data [Disabled/Enabled]: Default is **Disabled**. Select **Enabled** to reset Extended System Configuration Data (ESCD) when you exit Setup if you have installed a new add-on and the system reconfiguration has caused such a serious conflict that the OS cannot boot.

Resources Controlled by [Auto/Manual]: BIOS can automatically configure all the boot and plug & play compatible devices. If you choose Auto, you cannot select IRQ, DMA and memory base address fields, since BIOS automatically assigns them.

PCI/VGA Palette Snoop [Disabled/Enabled]: Some display cards that are nonstandard VGA, such as graphics accelerators or MPEG Video Cards, may not show colors properly. The setting **Enabled** should correct this problem. Otherwise, leave this on the setup default setting of **Disabled**. Recommend set **Disabled**.

3.2.5 Load Optimized Defaults

The option allows you to load the optimized default values for each of the parameters on the Setup menus. When this option is pressed, a confirmation is requested. Select “Y” to load the optimized default values. Select “N” or Press “Esc” to discard the selection.

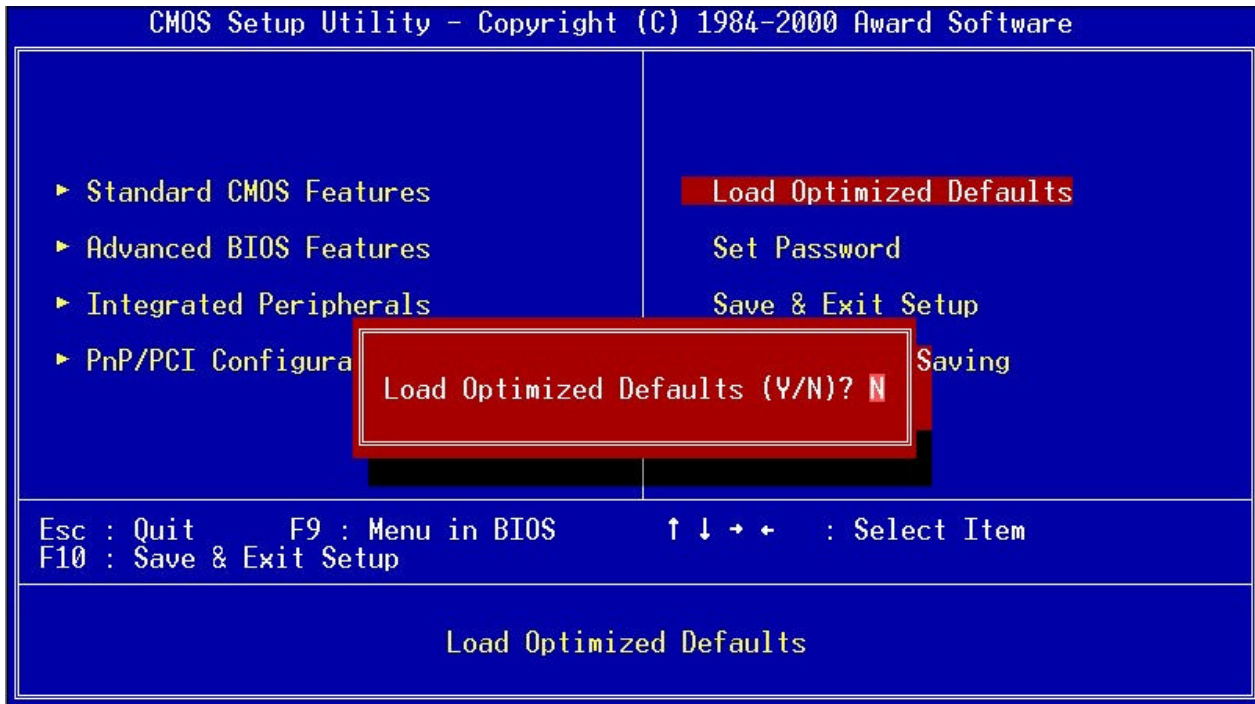

3.2.6 Set Password

The option allows you to set or change user password. To set the user password, press “**Enter**”. Type password and press “**Enter**”. You can type up eight alphanumeric characters.

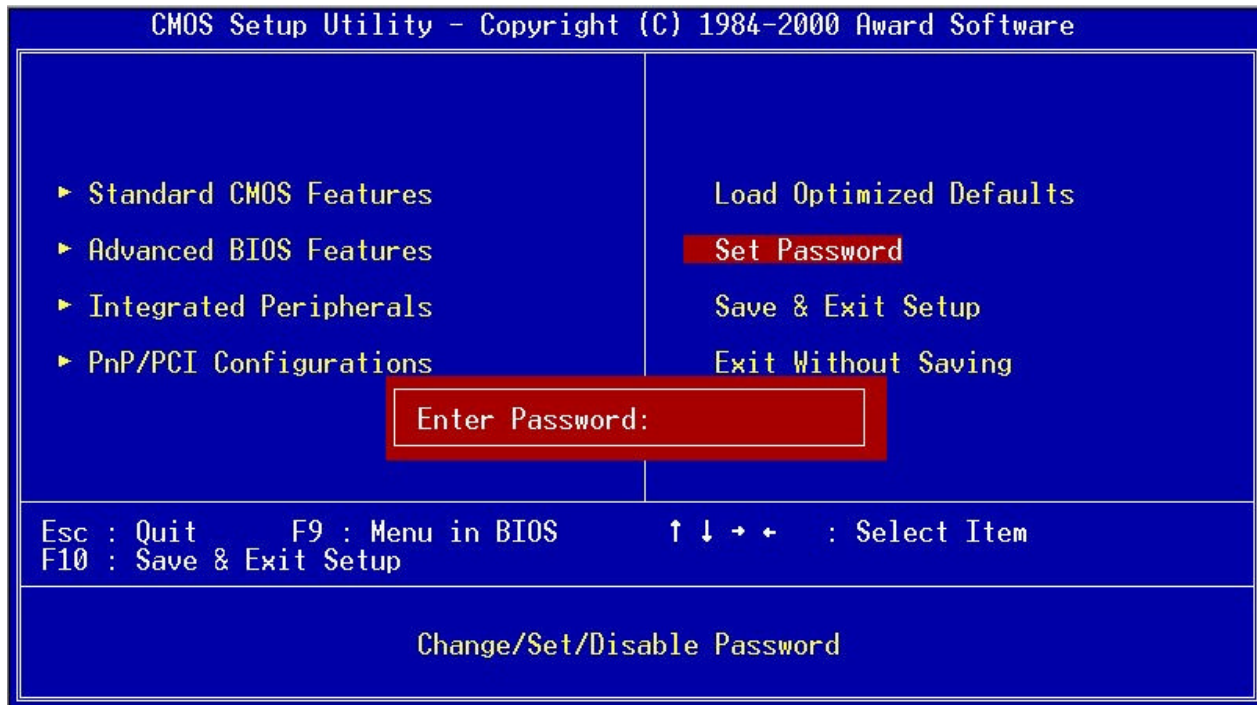

If the CMOS is good or if this option has been used to change the default password, the user is asked for the password stored in the CMOS. The screen will display the following message:

Confirm Password:

Input the current password and press “**Enter**”.

3.2.7 Save & Exit Setup

Once you finish your selection, choose the option to save the values you selected to CMOS RAM. The CMOS RAM is sustained by an on board backup battery and stays on even system is turned off. Once the option is selected, a confirmation is asked. Select “Y” to save changes and exit.

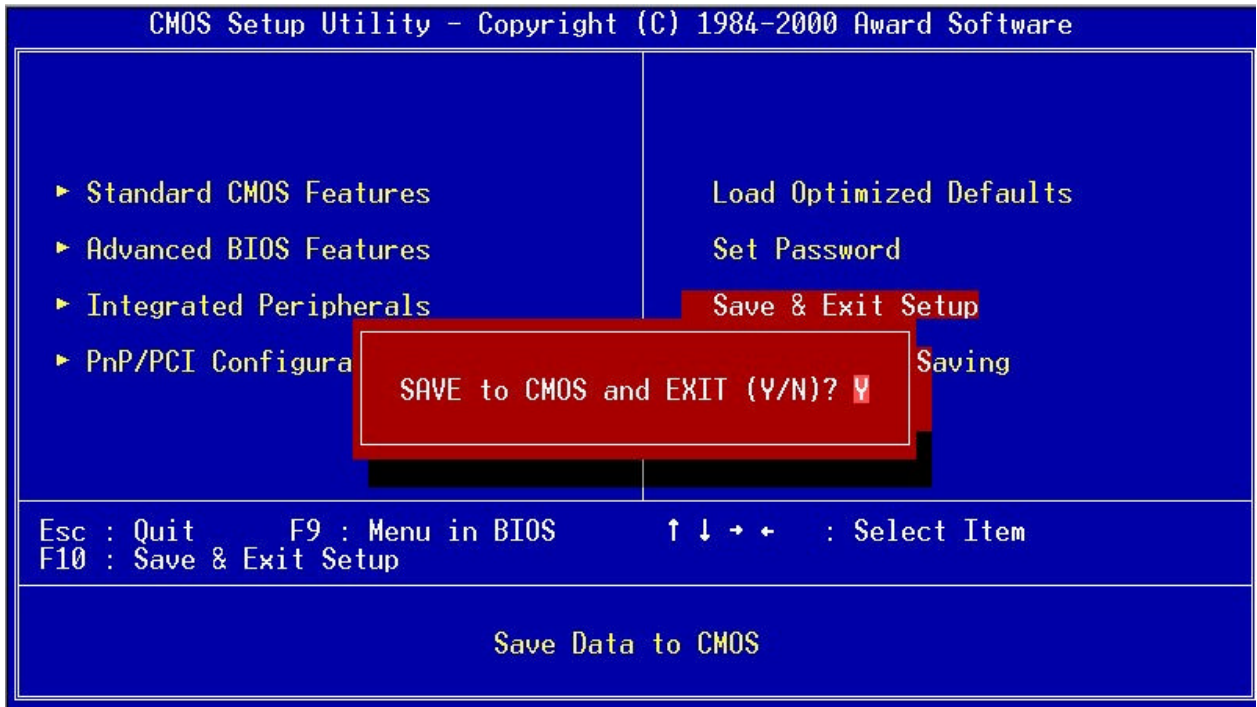

3.2.8 Exit without Saving

The option should only be used if you do not want to save the changes you have made to the Setup program. If you have made changes to the fields, the system will ask for confirmation before existing. Select “Y” then the system will keep previous values.

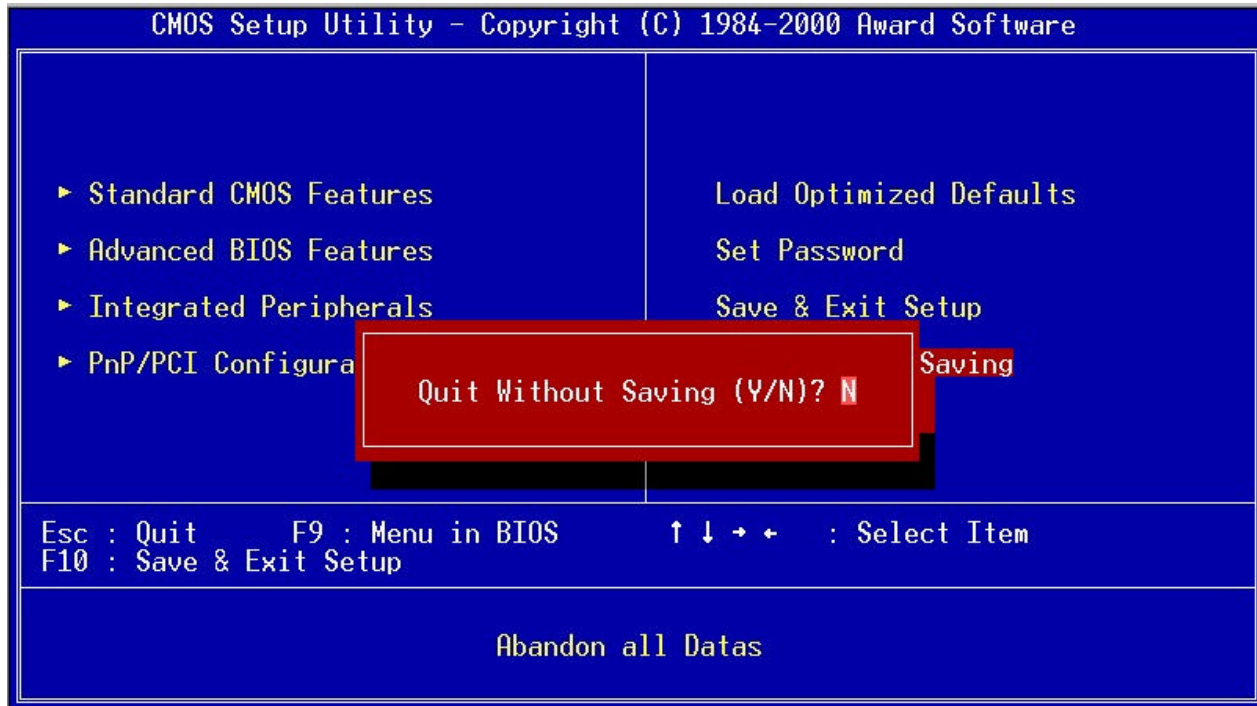

Chapter 4 OS Installation

The server comes with driver support software for several Operating Systems including Microsoft Windows NT 4.0/ 2000, Linux and Free BSD 4.x. The Driver Bank CD-ROM disc has driver software for the Windows NT 4.0 and Windows 2000 for the main sever components including:

Windows NT 4.0 Supporting Driver

- VGA-display driver
- LAN- NIC driver
- SCSI-LSI SCSI driver

Windows 2000 Supporting Driver

- LAN- NIC driver
- SCSI-LSI SCSI driver

There are also two Windows support floppy disks. These disks have copies of the LSI SCSI drivers that are on the Driver Bank CD-ROM. One floppy disk is for Windows 2000, the other for Windows NT 4.0. There is documentation on the disks.

Unix-like Operating System support includes support for the Linux and Free BSD Operating Systems. The support software includes:

- Drivers on the Driver Bank CD-ROM disc
- Red Hat Linux 6.2 Boot & Installation floppy disks

4.1 Installing Windows NT 4.0 Support Driver

The floppy disks with the SCSI drivers for Windows NT 4.0 and Windows 2000 have “readme” and other text files on them with installation details. The following sections give procedures for installing the SCSI drivers during the operating system installation process.

- **LSI Symbios 53C1010 SCSI Driver for Windows NT 4.0**

Driver Installation during Windows NT Install

1. CD-ROM Install: Boot from the CD-ROM and press <F6> while the message ‘**Setup is inspecting your computer’s configuration..?**’.
2. When the “**Welcome to Setup**” window is generated, press “**Enter**”.
3. In the “**Setup Method**” dialog box, press “**Enter**” to confirm “**Express Setup**”.
4. Press “**S**” to add a SCSI adapter.
5. Specify “**a:**”, insert the “**LSI Symbios 53C1010 SCSI Driver for Windows NT 4.0**” diskette into Drive A: and press “**ENTER**”.
6. Select the “**LSI Logic Ultra3 PCI SCSI Driver**” and click “**OK**”.

Note: for CD-ROM installations, you must also specify the driver for your CD-ROM adapter.

Follow the normal Windows NT 4.0 setup installation procedure. Please check other drivers in Driver Bank.

4.2 Installing Windows 2000 Support Driver

- **LSI Symbios 53C1010 SCSI Driver for Windows 2000**

Driver Installation during Windows 2000 Install

1. CD-ROM Install: Boot from the CD-ROM and press <F6> while the message “**Setup is inspecting your computer’s configuration...?**”.
2. When the “**Welcome to Setup**” window is generated, press “**Enter**”.
3. In the “**Setup Method**” dialog box, press “**Enter**” to confirm “**Express Setup**”.
4. Press “**S**” to add a SCSI adapter.
5. Specify “**a:**”, insert the “**LSI Symbios 53C1010 SCSI Driver for Windows 2000**” diskette into Drive A: and press “**ENTER**”.
6. Select the “**LSI Logic Ultra3 PCI SCSI Driver**” and click “**OK**”.

Note: for CD-ROM installations, you must also specify the driver for your CD-ROM adapter.

Follow the normal Windows 2000 setup installation procedure. Please check other drivers in Driver Bank.

4.3 Installing Linux/ Free BSD Support Software

To install Free BSD OS, please use default VGA, SCSI and LAN drivers because the OS has bundled the drivers already.

As mentioned, the server comes with a variety of support software for Linux. This includes a distribution of Red Hat Linux 6.2 sufficient to install the supplied driver software.

4.3.1 Red Hat Installation Procedures

1. BIOS need set the first boot device from floppy in CMOS Setup.
2. Insert the “**Linux Red-Hat 6.2 Installation Disk**” in the floppy disk drive and insert the “**Linux Red-Hat 6.2**” in the CD-ROM Drive. User needs buy the “**Linux Red-Hat 6.2**” OS Disc CD from other suppliers.
3. Type “**text**” or press “**Enter**”
4. Choose “**custom install**” (recommended).
5. Make sure the root partition (lilo boot partition) is “**dev/sdal**”
6. Make sure the /partition size < 1024Mbytes (New version of lilo can solve this problem).
7. When you install packages, you must choose “**kernel development & utilities**”.
(If you didn’ t do this, you must install the Red-Hat Linux source code during compiler:
 - `mount -t iso9660 /dev/cdrom /mnt/cdrom`
 - `cd /RedHat/RPMS`
 - `rpm -i kernel-source-2.2.14-5.0.i386.rpm`
8. After installing Red-Hat 6.2, please insert “**Linux Red-Hat 6.2 Boot Disk**” and reboot the system.

This completes the installation of installing Red-Hat 6.2 and you can now login to Red-Hat 6.2, but you still cannot boot the system from your SCSI HDD now! Please go to next step.

4.3.3 Installing A Network Driver for Red Hat 6.2

1. Insert the " **LSI Symbios 53C1010 SCSI Driver Patch & Intel 82559 Driver for Linux** " diskette to floppy disk drive.
2. Execute the commands in steps 3 to 7 in sequence.
3. **mount /dev/fd0 /mnt/floppy**
4. **cp /mnt/floppy/e100-1.3.14.tgz /home**
5. **cd /home**
6. **tar zxvf e100-1.3.14.tgz**; This step will create a new directory named "e100-1.3.14"
7. **cd /e100-1.3.14**
8. Please refer other steps with the **README** file.

Appendix A Memory Approval List

| No. | Vendor | Model Name | Die | Capacity |
|-----|--------|-----------------|----------------------------|-----------------------------|
| 1 | SMART | SM572164574E63R | SAMSUNG K4S640432D-TC75 | 128MB (PC133 REGISTERED) |
| 2 | SMART | SM572324574E03R | SAMSUNG K4S280432B-TC75 | 256MB (PC133 REGISTERED) |
| 3 | SMART | SM572644578E63R | SAMSUNG K4S560432A-TC75 | 512MB (PC133 REGISTERED) |
| 4 | SMART | SM572284578E83R | | 1GB (PC133 REGISTERED) |
| 5 | ATP | AR16V72C4S4GAS | SAMSUNG KM44S16030CT-G7 | 128MB (PC133 REGISTERED) |
| 6 | ATP | AR32V72C4S4GAS | SAMSUNG K4S280432A-TC75 | 256MB (PC133 REGISTERED) |
| 7 | ATP | AR64V72C4S8GAS | SAMSUNG K4S560432A-TC75 | 512MB (PC133 REGISTERED) |
| 8 | ATP | AR128V72C4SSGAS | SAMSUNG SEC 12950-37 | 1GB (PC133 REGISTERED) |

Appendix B. RAID Card Approval List

| No. | Vendor | Model Name |
|-----|--------|-----------------------------------|
| 1 | AMI | MegaRAID Express 200 (Series 466) |
| 2 | AMI | MegaRAID Express 500 (Series 475) |
| 3 | Mylex | AcceleRAID 170 |
| 4 | Mylex | AcceleRAID 352 |

Appendix C Driver Bank

Driver Bank:

In this CD, there are some options as below when run “**Setup**” or CD auto-run.

1. **RS100/200-VF Drivers**
2. **RS100/200-RF Drivers**
3. **Browse CD Contents**
4. **View Our Website**
5. **Contact Us**
6. **Exit**

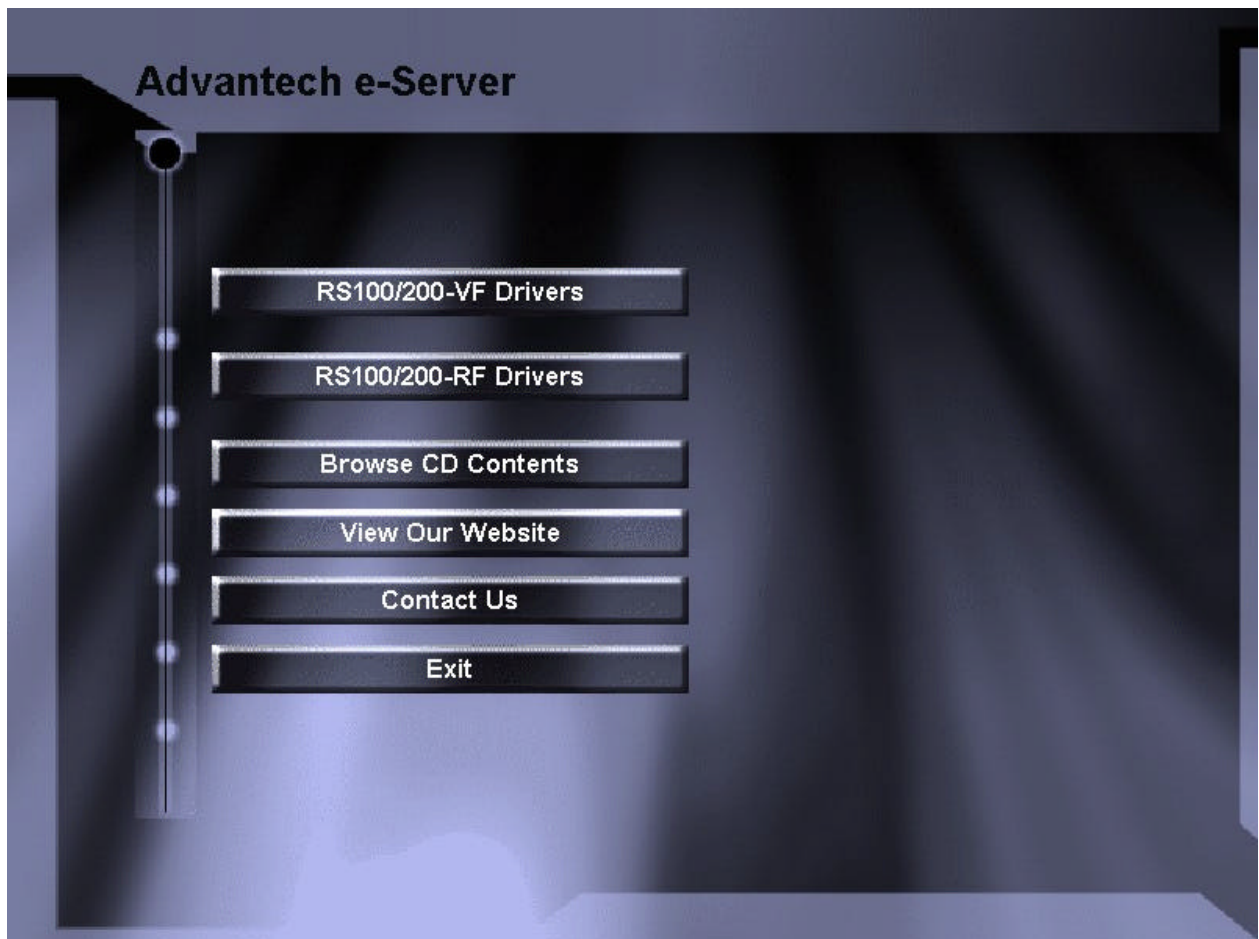

You can click “**RS100/200-RF Drivers**” to install drivers. There are some options as follows.

1. **Install VGA Driver**
2. **Install LAN Driver**
3. **Install SCSI Driver**

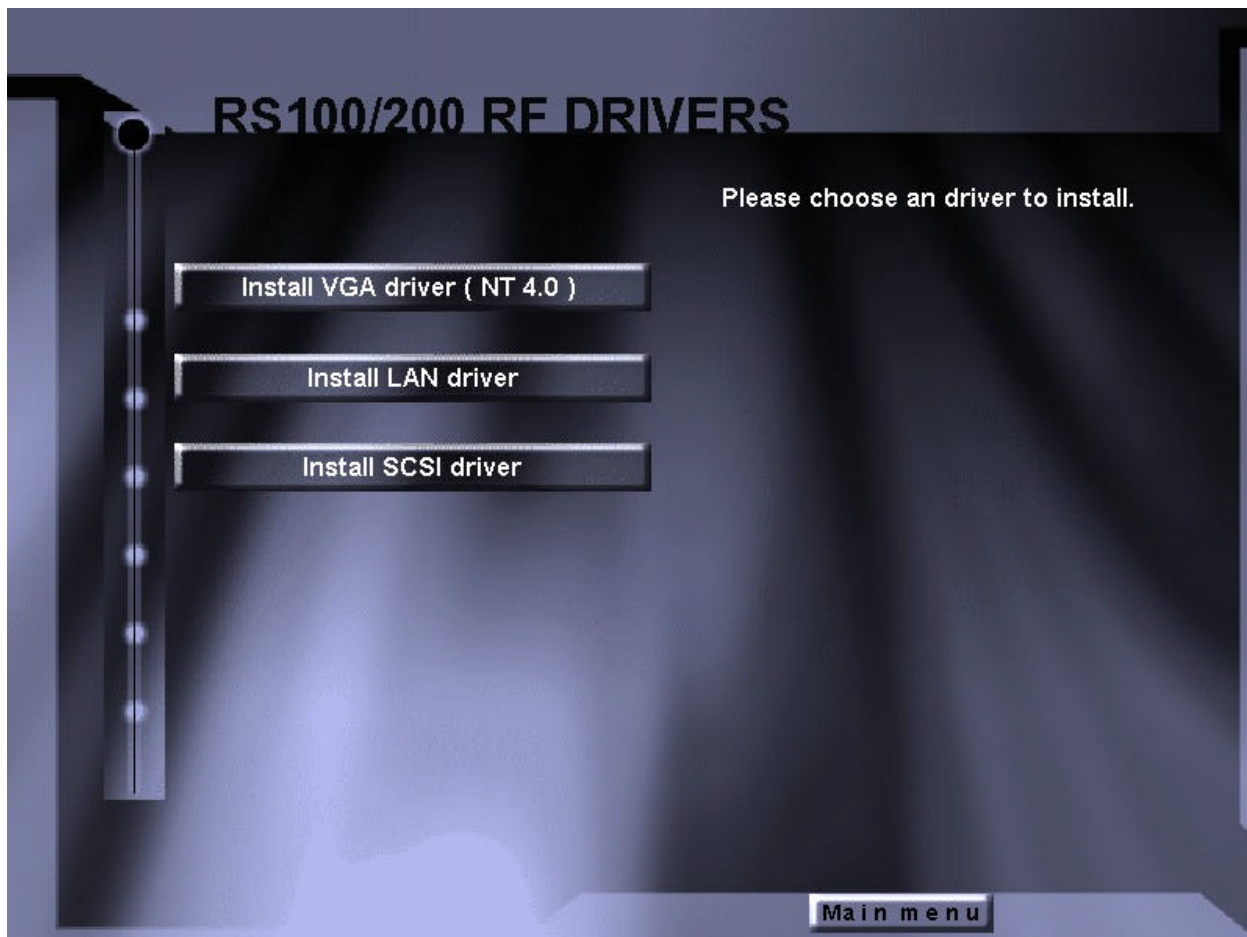

1. Install VGA Driver (For Windows NT 4.0)

Click the selection and it setup automatically.

2. Install LAN Driver

Please go to the following subdirectory when system requests LAN driver during OS installation.

rs100_200_rf\82559

\LAN – Drivers for Windows NT 4.0, NetWare, and Unix

\RedHat 6.2 – Drivers for Linux

3. Install SCSI Driver

Please go to the following subdirectory when system requests SCSI driver during OS installation.

rs100_200_rf\LSI SCSI\WIN2000 – Symbios device drivers for Windows 2000

rs100_200_rf\LSI SCSI\WINNT – Symbios device drivers for Windows NT 4.0.

rs100_200_rf\LSI SCSI\RedHat 6.2

rs100_200_rf\LSI SCSI\Utility \BROWSER – LSI DMI Browser.

\DOS – DOS Utility.

\WINDOWS – Windows Utility.

Appendix D Safety Instructions

D.1 English

1. Read these safety instructions carefully.
2. Keep this user's manual for later reference.
3. Disconnect this equipment from any AC outlet before cleaning. Do not use liquid or spray detergents for cleaning. Use a damp cloth.
4. For pluggable equipment, the power outlet must be installed near the equipment and be easily accessible.
5. Keep this equipment away from humidity
6. Put this equipment on a reliable surface during installation. Dropping it or letting it fall could cause damage.
7. The openings on the enclosure are for air convection. Protect the equipment from overheating. **DO NOT COVER THE OPENINGS.**
8. Make sure the voltage of the power source is correct before connecting equipment to the power outlet.
9. Position the power cord so that people cannot step on it. Do not place anything over the power cord.
10. All cautions and warnings on the equipment should be noted.
11. If the equipment is not used for a long time, disconnect it from the power source to avoid damage by transient over-voltage.
12. Never pour any liquid into an opening. This could cause fire or electrical shock.
13. Never open the equipment. For safety reasons, the equipment should be opened by qualified service personnel only.
14. If any of the following situations arises, get the equipment checked by service personnel.
 - a. The power cord or plug is damaged.
 - b. Liquid has penetrated into the equipment.
 - c. The equipment has been exposed to moisture.
 - d. The equipment does not work well, or you cannot get it to work well according to the installation reference guide.
 - e. The equipment has been dropped and damaged.
 - f. The equipment has obvious signs of breakage.
15. **DO NOT LEAVE THIS EQUIPMENT IN AN UNCONTROLLED ENVIRONMENT WHERE THE STORAGE TEMPERATURE IS BELOW -20 (-4) OR ABOVE 60 (140). THE MAY DAMAGE THE EQUIPMENT.**

The sound pressure level at the operator's position according to IEC 704-1; 1982 is equal to or less than 70dB(A).

DISCLAIMER: This set of instructions is given according to IEC 704-1. Advantech disclaims all responsibility for the accuracy of any statements contained herein.

D.2 German- Wichtige Sicherheitshinweise

1. Bitte lesen Sie sich diese Hinweise sorgfältig durch.
2. Heben Sie diese Anleitung für den späteren Gebrauch auf.
3. Vor jedem Reinigen ist das Gerät vom Stromnetz zu trennen. Verwenden Sie keine Flüssig- oder Aerosolreiniger. Am besten dient ein angefeuchtetes Tuch zur Reinigung.
4. Die Netzanschlusstekdose soll nahe dem Gerät angebracht und leicht zugänglich sein.
5. Das Gerät ist vor Feuchtigkeit zu schützen.
6. Bei der Aufstellung des Gerätes ist auf sicheren Stand zu achten. Ein Kippen oder Fallen könnte Verletzungen hervorrufen.
7. Die Belüftungsöffnungen dienen zur Luftzirkulation die das Gerät vor Überhitzung schützt. Sorgen Sie dafür, dass diese Öffnungen nicht abgedeckt werden.
8. Beachten Sie beim Anschluss an das Stromnetz die Anschlusswerte.
9. Verlegen Sie die Netzanschlusleitung so, dass niemand darüber fallen kann. Es sollte auch nichts auf der Leitung abgestellt werden.
10. Alle Hinweise und Warnungen die sich an den Geräten befinden sind zu beachten.
11. Wird das Gerät über einen längeren Zeitraum nicht benutzt, sollten Sie es vom Stromnetz trennen. Somit wird im Falle einer Überspannung eine Beschädigung vermieden.
12. Durch die Lüftungsöffnungen dürfen niemals Gegenstände oder Flüssigkeiten in das Gerät gelangen. Dies könnte einen Brand bzw. elektrischen Schlag auslösen.
13. Öffnen Sie niemals das Gerät. Das Gerät darf aus Gründen der elektrischen Sicherheit nur von autorisiertem Servicepersonal geöffnet werden.
14. Wenn folgende Situationen auftreten ist das Gerät vom Stromnetz zu trennen und von einer qualifizierten Servicestelle zu überprüfen:
 - a. Netzkabel oder Netzstecker sind beschädigt.
 - b. Flüssigkeit ist in das Gerät eingedrungen.
 - c. Das Gerät war Feuchtigkeit ausgesetzt.
 - d. Wenn das Gerät nicht der Bedienungsanleitung entsprechend funktioniert oder Sie mit Hilfe dieser Anleitung keine Verbesserung erzielen.
 - e. Das Gerät ist gefallen und/oder das Gehäuse ist beschädigt.
 - f. Wenn das Gerät deutliche Anzeichen eines Defektes aufweist.
15. Bitte lassen Sie das Gerät nicht unbehehrt hinten unter -20 (-4) oder oben 60 (140), weil diesen Temperaturen das Gerät zerstören könnten.

Der arbeitsplatzbezogene Schalldruckpegel nach DIN 45 635 Teil 1000 beträgt 70dB(A) oder weniger.

DISCLAIMER: This set of instructions is provided according to IEC 704-1. Advantech disclaims all responsibility for the accuracy of any statements contained herein.