

FPM-3191G

Industrial 19" SXGA Flat Panel Monitor with Direct-VGA Port

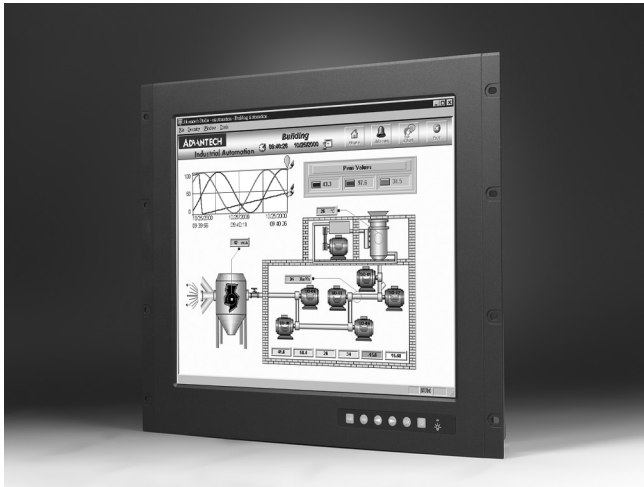

Features

- 19" SXGA TFT LCD with resolution up to 1280 x 1024
- Robust design with stainless steel chassis and aluminum front panel
- Hard anodic coating to prevent panel abrasion and acid corrosion
- Anti-reflective screen with tempered glass
- Supports stainless steel front panel (Customization)
- OSD control pad on front panel
- Supports transreflective LCD technology (Customization)
- Supports Panel, Wall, Desktop, Rack or VESA arm mounting
- NEMA4 / IP65 Compliant

Introduction

FPM-3191G is a 19" color TFT LCD flat panel monitor specifically designed for industrial applications. With a viewing size as large as 19", it presents an ample display area as well as vivid and sharp images for your HMI. It features Direct-VGA signal transmission and the on-screen display function makes it easy to adjust the images on the screen. The stainless steel chassis and the NEMA4/IP65 compliant aluminum front panel enable installation in applications with water and dust. An optional stainless steel front panel is available by request.

Specifications

General

- **Button Controls** OSD (Onscreen Display) control pad on front panel
- **Certification** BSMI, CCC, CE, FCC-B
- **Dimension (WxHxD)** 482 x 399.2 x 66 mm (19" x 15.7" x 2.6")
- **Enclosure** Front panel : Aluminum with hard anodic coating,
Rear cover : Stainless steel chassis
- **Mounting** Panel, wall, desktop, VESA arm, or 19" rackmount with optional mounting kit
- **Power Input** External 60 W power adapter, with AC 100 V ~ 240 V input and DC +12 V @ 5 A output
- **Video Port** VGA
- **Weight (Net)** 10.65 kg (23.46 lbs)

LCD Display

- **Display Type** SXGA TFT LCD (Fujitsu)
- **Display Size** 19"
- **Max. Resolution** 1280 x 1024
- **Max. Color** 16.7M
- **Viewing Angle (H, V)°** 170, 170
- **Luminance (cd/m2)** 300
- **Backlight Life (hrs)** 50,000
- **Contrast Ratio** 700 : 1

Touchscreen (Optional)

- **Sensor** ELO
- **Type** 5W Resistive, Capacitive
- **Interface** RS-232
- **Lifespan** 35 million touches at a single point
- **Light Transmission** 80%±5
- **OS support** DOS, Windows 95/98/ME/2000/XP/NT
- **Power Consumption** +5V @ 100 mA
- **Touch Resolution** 4096 x 4096

Environment

- **Operation Temperature** 0 ~ 50° C (32 ~ 122° F)
- **Storage Temperature** -20 ~ 60° C (-4 ~ 140° F)
- **Humidity (Storage)** 10 ~ 95% non-condensing
- **Waterproof** IEC529 IP65 (Front Panel)
- **Vibration** 5~500 Hz, 1 Grms (Operating, Random)

Ordering Information

- **FPM-3191GA** Industrial 19" SXGA Flat Panel Monitor
- **FPM-3191GA-C** FPM-3191GA with Capacitive touchscreen (RS-232 interface)

Dimensions

Unit: mm

Diameters of the rackmount holes:
Vertical: 6.5mm
Horizontal: 9mm

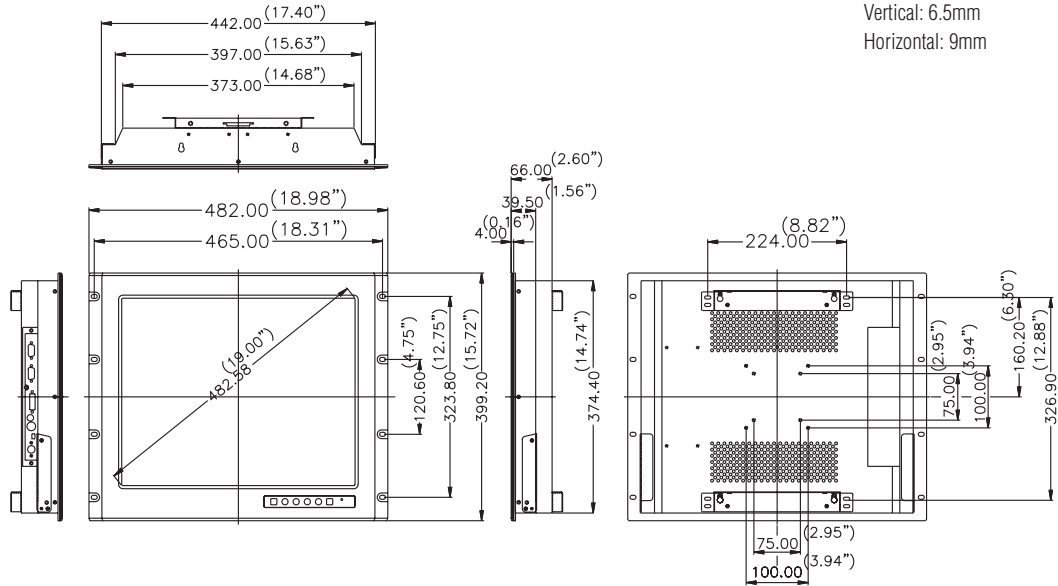

Cut-out dimension: 444 x 376 mm (17.48" x 14.84")

Side View

