

FPM-3155

Industrial 15" Flat Panel Monitor with VGA/DVI/Video/S-Video Port



Features

- 15" XGA TFT LCD with resolution up to 1024 X 768
- Stainless steel chassis with NEMA4/IP65-compliant aluminum front panel
- Multi-scan function supports XGA, SVGA, VGA, text mode
- Auto-recognition of input signal
- Rack, Panel or Wallmount
- Supports VESA arm, Desktop Stand
- Multi-signal input supports RGB, DVI, Video and S-Video

Introduction

The FPM-3155 is a 15-inch color TFT LCD flat panel monitor specifically designed for industrial applications. With a viewing size as large as 15", it presents an ample display area as well as vivid and sharp images for your HMI. The FPM-3155 features VGA, AV, S-Video signal input. Users can thus upgrade the display without making changes to the existing system. Its On Screen Display function also allows users to adjust the images on screen with ease. The whole chassis is stainless steel and the front panel is made of aluminum with NEMA4/IP65 compliance.

Specification

- **Front Panel:** aluminum, NEMA4/IP65 compliant
- **Mounting:** panel mount, wallmount, desktop, VESA Arm, or 19" rackmount with optional mounting kit
- **Dimensions (W x H x D):** 428 x 310 x 61 mm (16.6" x 12.2" x 2.4")
- **Gross Weight:** 7 kgs (15.4 lbs)
- **I/O Port:** VGA, DVI, Video, S-Video, DC power input, power switch, and RS-232 port (Touchscreen version only)
- **Control:** OSD (on screen display) control pads on the front panel
- **Power:** external 48 W power adapter, with AC 100 V ~ 230 V input and DC +12 V @ 4 A output
- **Operating Temperature:** 0° ~ 50° C (32° ~ 122° F)
- **Storage Temp:** -20° ~ 60° C (-4° ~ 140° F)
- **Storage Humidity:** 5 ~ 95 % non-condensing
- **Vibration (operating):** 5 ~ 17 Hz, double-amplitude displacement 17 ~ 500 Hz, 1.0 G peak to peak
- **CE, FCC, BSMI, CCIB compliant**

LCD Display

Display type	XGA TFT LCD
Display size	15"
Max. colors	262 K
Max. resolution	1024 x 768
View angle	120° (H), 100° (V)
Luminance	200 cd/m ²
Storage temperature	-20° ~ 60° C (-4° ~ 140° F)
Operating temperature	0° ~ 50° C (32° ~ 122° F)
Backlight lifetime	25,000 hrs
Contrast ratio	350 : 1 (typ.)

Touchscreen (optional)

- **Type:** 8 wire, analog resistive
- **Resolution:** continuous
- **Light Transmission:** 75%
- **Controller:** RS-232 interface
- **Power Consumption:** +5 V @ 200 mA
- **OS Support:** MS-DOS, Windows 3.1/95/98/NT/2000
- **Lifespan:** 100 million touches

CE FC BSMI

Industrial 15" Flat Panel Monitor with VGA/DVI/Video/S-Video Port

Dimensions

Unit: mm (inch)

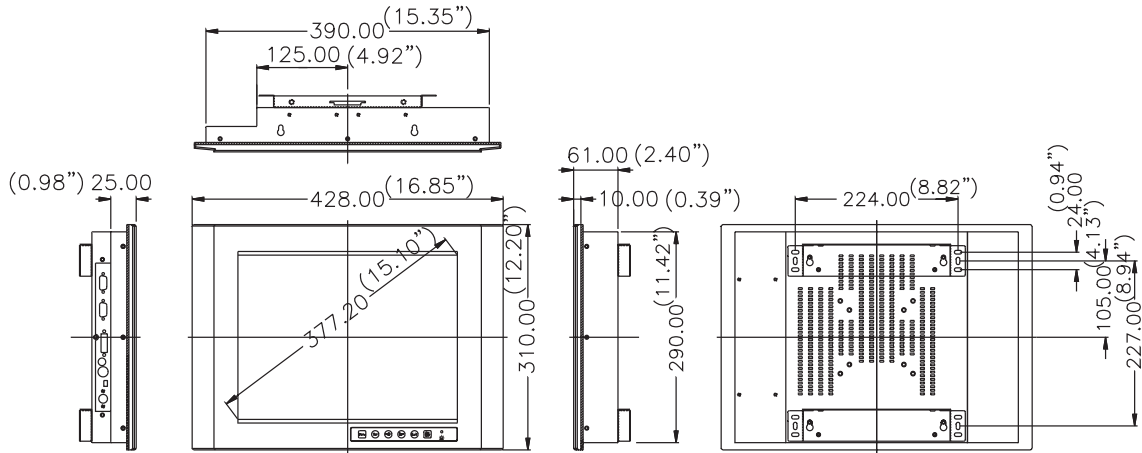

Cut-out dimension: 396 x 296 mm (15.6" x 11.6")

Side View

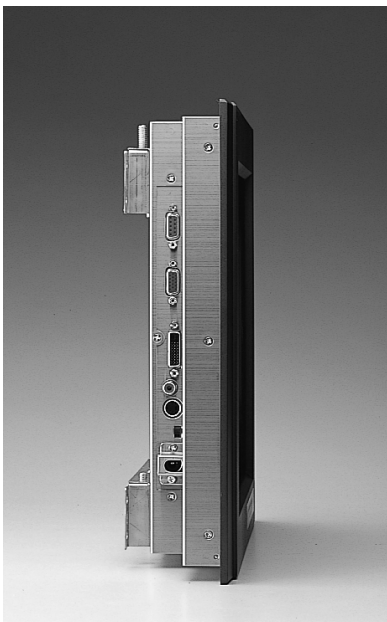

Ordering Information

- FPM-3155TV**
Industrial 15" TFT LCD display with VGA/ DVI/ Video interface and AC 100~230 V input 48W power adpater
- FPM-3155TV-T**
FPM-3155TV with analog resistive touchscreen (RS-232 interface)
- FPM-3150 Rack-MT**
Mounting kit for 19" industrial rack

Accessories

- 1700155001** 50 M VGA cable for FPM-series
- 1700153000** 30 M VGA cable for FPM-series
- 1700152000** 20 M VGA cable for FPM-series
- 1700151000** 10 M VGA cable for FPM-series
- 1700155000** 5 M VGA cable for FPM-series
- 9689000355** RS-232/485 converter for T/S (USA)
- 9689000356** RS-232/485 converter for T/S (UK)
- 9689000357** RS-232/485 converter for T/S (FR)
- 1700090000** 10 M cable for T/S
- 1700090001** 4.5 M cable for T/S
- 1700090002** 3 M cable for T/S