

FPM-3150G

15" XGA Industrial Monitor with Resistive Touchscreen, Direct-VGA and DVI Ports



Features

- High brightness 550 nits LCD display
- Direct VGA & DVI-D video input interface
- Lockable OSD keys with 2 user-defined contrast/brightness settings
- Combo RS-232 & USB interface for touchscreen function (optional)
- Robust design with stainless steel chassis and aluminum front panel
- Supports industrial 24-48 V_{DC} power input (optional)
- Supports Panel, Wall, Desktop, Rack or VESA arm mounting
- Front Panel NEMA4/IP65 Compliant

Introduction

FPM-3150G is a 15" color TFT LCD flat panel monitor specifically designed for industrial applications. With a viewing size as large as 15", it presents an ample display area as well as vivid and sharp images for your HMI. It features Direct-VGA & DVI-D signal transmission, which allows a regular VGA control card to be used in your system. Users can thus upgrade the display without making changes to the existing system. Its on screen display function also allows users to adjust the images on the screen with ease. The whole chassis is stainless steel and the front panel is made of aluminum with front panel NEMA4/IP65 compliance.

Specifications

General

- **Button Controls** OSD control pad on front panel with lockable function
- **Certification** BSMI, CCC, CE, FCC
- **Dimension (W x H x D)** 422 x 310 x 86 mm (16.6" x 12.2" x 3.4")
- **Enclosure** Front panel: Aluminum with coating, Rear cover: Stainless steel chassis
- **Mounting** Panel, wall, desktop, VESA arm, or 19" rackmount with optional mounting kit
- **Power Input** External 50 W power adapter, with AC 100 V ~ 240 V input and DC +12 V @ 4.16 A output
- **Video Port** VGA & DVI-D
- **Weight (Net)** 7.73 kg (17.04 lbs)

LCD Display

- **Display Type** XGA TFT LCD
- **Display Size** 15"
- **Max. Resolution** 1024 x 768
- **Max. Color** 16.2M
- **Viewing Angle (H, V)°** 140, 120
- **Luminance (cd/m²)** 550
- **Backlight Life (hrs)** 50,000
- **Contrast Ratio** 500 : 1

Touchscreen (Optional)

- **Type** 8-wire Resistive
- **Interface** RS-232 & USB
- **Lifespan** 10 million with a silicone rubber of R8 finger, writing rate is by 250g at 2 times/s
- **Light Transmission** > 80%
- **OS Support** Windows® 95/98/ME/2000/XP/CE/NT/Vista, Linux
- **Power Consumption** +5 V @ 100 mA
- **Touch Resolution** Linearity

Environment

- **Operation Temperature** 0 ~ 50° C (32 ~ 122° F)
- **Storage Temperature** -20 ~ 60° C (-4 ~ 140° F)
- **Humidity (Storage)** 10 ~ 95% non-condensing
- **Waterproof** Front Panel NEMA4/IP65 Compliant
- **Vibration** 5 ~ 500 Hz, 1 Grms (Operating, Random)

Ordering Information

- **FPM-3150G-XCE** 15" Industrial Monitor with D-VGA & DVI-D ports
- **FPM-3150G-RCE** FPM-3150G-XCE with Resistive Touchscreen RS-232 & USB Interface

Dimensions

Unit: mm

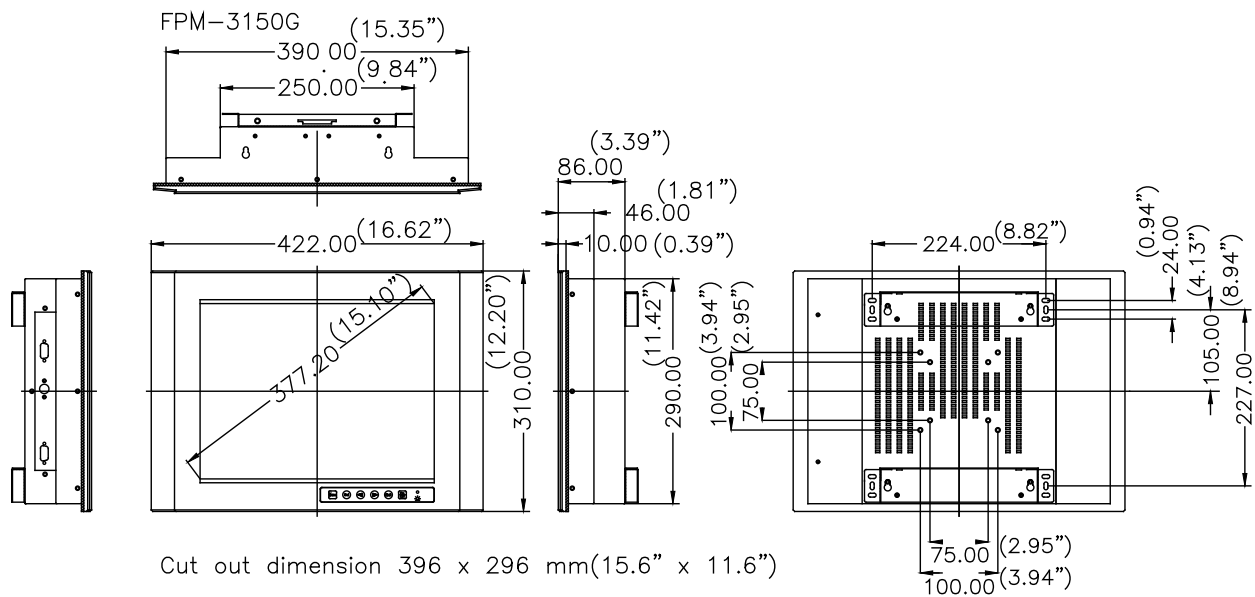

Accessories

- **FPM-3150G-RMKE** Mounting kit for 19" industrial rack
- **PWR-246E** Ind. DC to DC Converter w/24-48 V_{DC} Power Input
- **1702002600** Power Cable US Plug 1.8 M
- **1702002605** Power Cable EU Plug 1.8 M
- **1702031801** Power Cable UK Plug 1.8 M
- **1702031836** Power Cable China/Australia Plug 1.8 M

Rack Mount (FPM-3150G-RMKE)



Side View

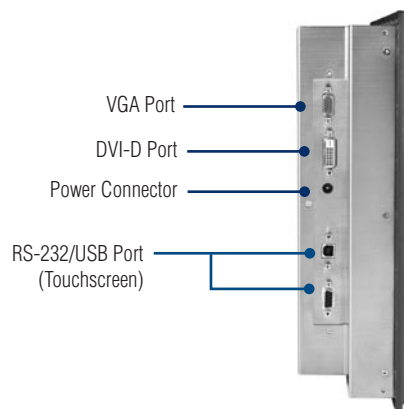

Mounting with DC Source

