

FPM-30/3100

Industrial 10.4" Flat Panel Monitor

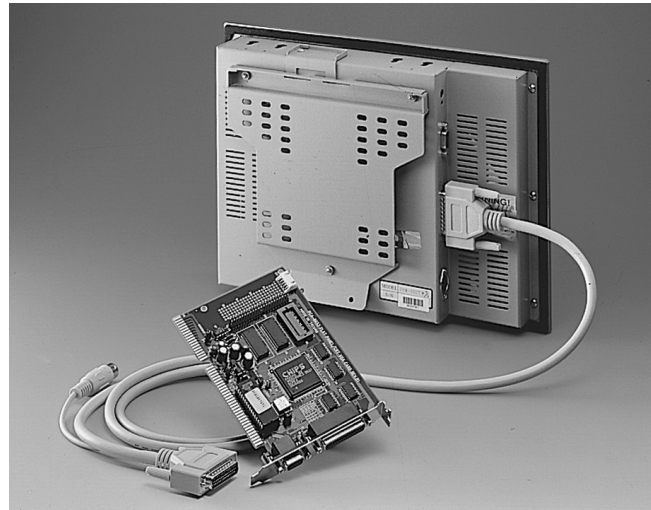
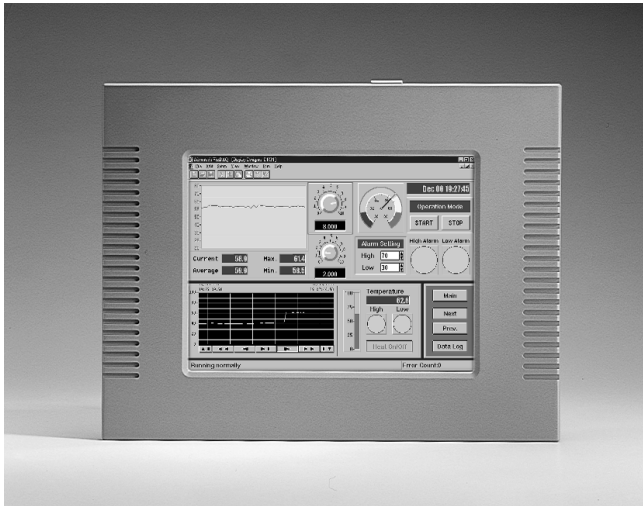

Introduction

The FPM-30/3100 series are flat panel monitors with 10.4" color TFT/DSTN LCDs. Being less than 2" in depth, the FPM-30/3100 is space saving and light enough to fit almost anywhere. Equipped with an optional touchscreen, the FPM-30/3100 even can be used as a remote display or controller for applications. Each model comes with a 1.8 m cable, optional 4.5 m and 10 m cables are available for extended display needs.

Specifications

- **Front panel:** aluminium panel with anodized treatment, meets NEMA4/IP 65
- **Mounting:** Panel or wall mount
- **Dimensions (W x H x D):**
FPM-30: 330 x 242 x 50 mm (13" x 9.5" x 2")
FPM-3100: 342 x 265 x 45 mm (13.5" x 10.4" x 1.8")
- **Gross Weight:**
FPM-30: 5.4 kg (12 lbs)
FPM-3100: 4.5 kg (8 lbs)

PCA-6653 ISA VGA Card (FPM-30)

- **Type:** Half-size 16-bit ISA-bus
- **Video chip:** Chips 65545
- **DRAM:** On-board 1 MB, frame buffer 512 KB (optional)
- **Max. resolution:** 1024 x 768 for both flat panels and CRTs
- **Connectors:** One DB-44 connector for flat panel display
One DB-15 connector for CRT monitor
- Supports simultaneous CRT/LCD display
- **Power consumption:** +5 V @ 1 A, max.

PCA-6654 PCI VGA Card (FPM-3100)

- **Type:** Half-size 32-bit PCI-bus
- **Video chip:** Chips 65550
- **DRAM:** On-board 2 MB, frame buffer 512 KB (optional)
- **Max. resolution:** 1024 x 768 for both flat panels and CRTs

- **Connectors:** One MDR-26 connector for flat panel display
One DB-15 connector for CRT monitor
- **Simultaneous CRT/LCD display**
- **Power consumption:** +5 V @ 1 A, max.

Touchscreen (optional)

- **Type:** Analog resistive, continuous resolution
- **Light transmission:** 75%
- **Controller:** RS-232 interface
- **Power consumption:** +5 V @ 200 mA
- **Durability:** 35 million touch lifetime
- **Software driver:** Supports DOS, Windows 3.1/95/98/NT

Flat Panel Display

Model	FPM-30CT	FPM-3100HT/T
Display type	10.4" TFT	10.4" TFT
Max. resolution	640 x 480	800 x 600/640 x 480
Max. colors	256 K	256 K
Dot size (mm)	0.33 (H) x 0.33 (V)	0.26 x 0.26/0.33 x 0.33 (H x V)
Luminance (cd/m ²)	250	250
Viewing angle	90°	90°
Operating temperature	0 ~ 50° C	0 ~ 50° C
Simultaneous mode	Yes	Yes
LCD MTBF	25,000 hours	25,000 hours
Backlight MTBF	50,000 hours	50,000 hours
Certification	N/A	CE
Signal Transmit	TTL Digital	PanelLink Digital
VGA card	PCA-6653, ISA bus	PCA-6654 B, PCI bus

Installations

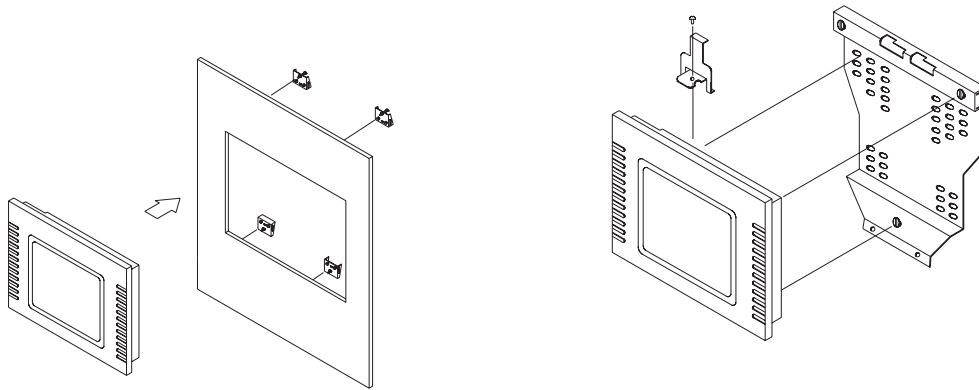

I/O connections FPM-30

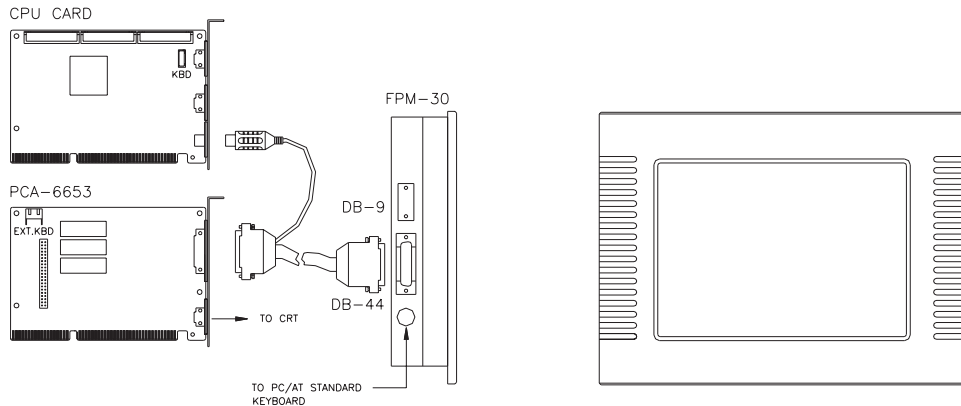

Ordering Information

- ❑ **FPM-30CT**
10.4" TFT LCD, ISA VGA card & 1.8 m cable
- ❑ **FPM-3100HT**
10.4" SVGA TFT LCD, PCI VGA card & 1.8 m cable
- ❑ **FPM-3100T**
10.4" VGA TFT LCD, PCI VGA card & 1.8 m cable
- ❑ **FPM-30CT-T**
FPM-30CT-T + touchscreen (RS-232 interface)
- ❑ **FPM-3100HT-T**
FPM-3100HT-T + touchscreen (RS-232 interface)
- ❑ **FPM-3100T-T**
FPM-3100T-T + touchscreen (RS-232 interface)

Accessories

- ❑ **1700440000**
44-Pin 10m HD D-SUB shielded cable for FPM-30CT
- ❑ **1700444500**
44-Pin 4.5m HD D-SUB shielded cable for FPM-30CT
- ❑ **1700261000**
26-Pin 10m PanelLink shielded cable for FPM-3100HT/3100T
- ❑ **1700264500**
26-Pin 4.5m PanelLink shielded cable for FPM-3100HT/3100T
- ❑ **1700090000**
9P/9P, 10m M/F RS-232 touchscreen cable for Touchscreen version of FPM-3100/30 series
- ❑ **1700090001**
9P/9P, 4.5m M/F RS-232 touchscreen cable for Touchscreen version of FPM-3100/30 series

Dimensions

(FPM-3100)

Unit: mm (inch)

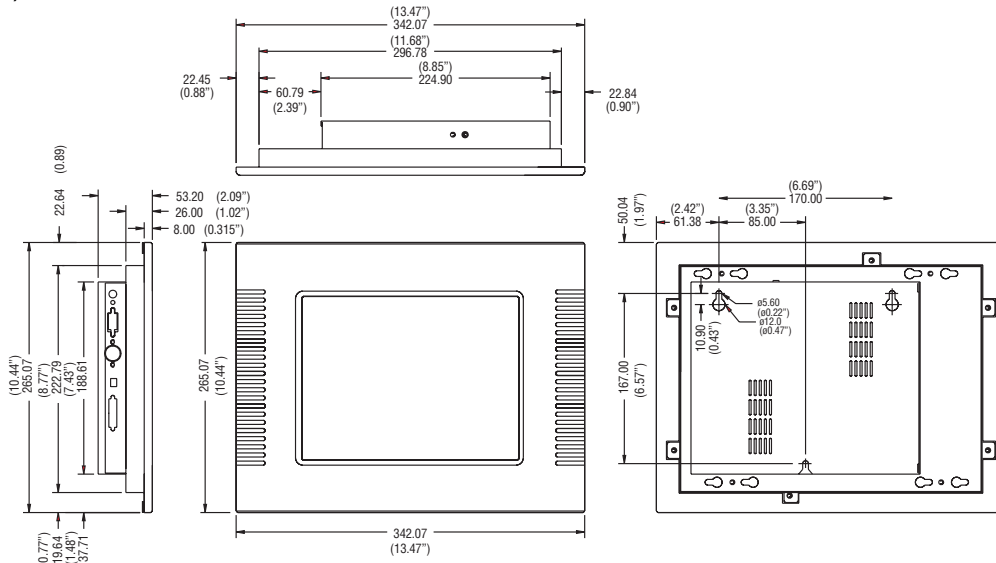

**Cutout dimensions: 305 mm x 230 mm
(12" x 9.05")**

Dimensions

(FPM-30)

Unit: mm (inch)

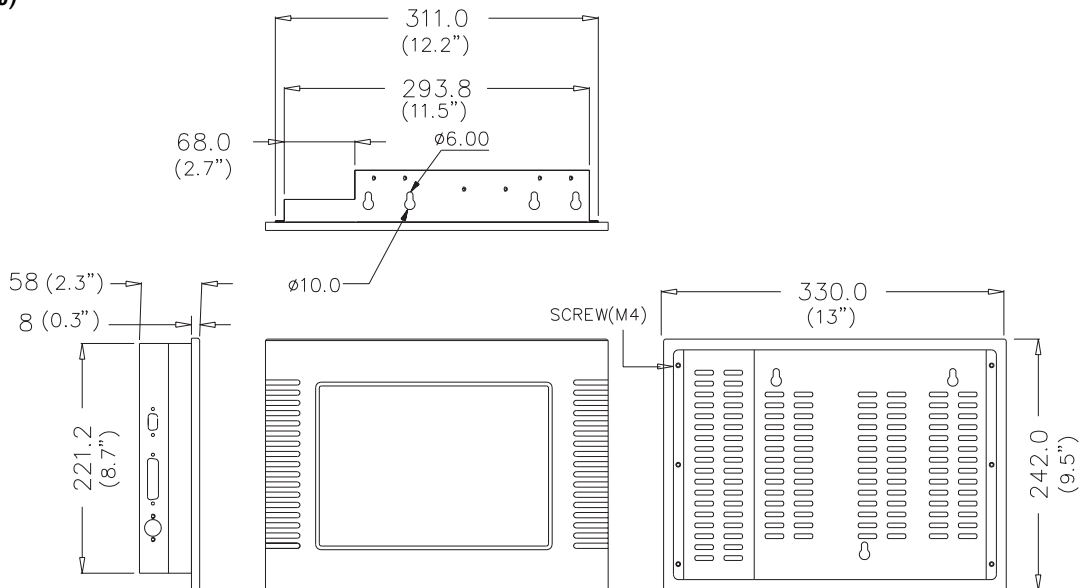

**Cutout dimensions: 305 mm x 230 mm
(12" x 9")**