



Introduction

The ES-530 is an interactive multimedia Web payphone that features the combination of a conventional public phone and full Internet capability. This unit merges the convenience of multimedia functionality and e-commerce with the traditional uses of a telephone. Internet access is through an ADSL broadband network, allowing voice service and on-line shopping service. With an embedded CCD camera, video-calling, video mail, and remote viewing are all available. Among the call payment options, there is a payment setting with an IC/Magnetic Stripe card reader. There is even advertising space on-screen, creating limitless marketing opportunities. The user-friendly touch screen LCD eases on-line shopping capabilities with business transactions recorded on a hard copy receipt from the built-in thermal printer. The ES-530 Web payphone has a durable aluminum alloy die-cast housing integrated with a tough touch screen that provides a friendly HMI (Human Machine Interface), making it vandal resistant yet attractive to the public. The ES-530 is a good solution for telecommunication enterprises, Internet service providers, the media and those who want to link their business to the eWorld.

Features:

- **Impact-Resistant Touch screen - simple and easy to use, but also secure**
- **Versatile Peripherals - thermal printer, card reader, CCD camera**
- **Broadband Connection - equipped for ADSL for Internet and voice communications**
- **Reliable - All-in-One industrial SBC for stability and easy maintenance**
- **Robust - Watch dog timer to reboot during system hang-up**
- **Payment - IC phone card / credit card accepted**
- **Multimedia - Audio/video function, video conferencing capability**
- **Voice Call - Same as conventional public phone**

Specifications

Computing:

- 10.4" high brightness (500 nits) TFT LCD display
- Capacity Tough touch screen (8 mm)
- All-in-One SBC with Celeron or Pentium III 850 Mhz
- Up to 256 MB SDRAM
- Compact Flash™ removable memory card

Multimedia:

- **Audio:** Sound blaster compatible
- **Speaker:** 2 x 3 watts

Payment:

- ISO 7816 compatible Smart card reader.
- ISO 7811 compatible magnetic stripe card, supports 1 & 2 or 2 & 3 tracks

Telephone interface:

- Programmable tariff table set on PC
- Dialing method: DTMF
- Compatible with most of switching systems

Broadband Access:

- ADSL, Access up to 8 Mbs

CCD Camera:

- Interface: USB port
- Image sensor: 1/4" color CCD, 350K pixel
- Frame rate: 640 x 480@18 fps, 352 x 288@30 fps
- View angle: 52° (Horizontal)

Thermal printer:

2" Thermal Printer (optional: 3" Thermal Printer)

Power Supply:

- **Input:** 100 V ~ 120 V / 200 ~ 240 V
- **Output rating:** 150 Watts

Mechanical:

- **Dimensions:** 516 mm (H) x 326 mm (W) x 243 mm (D)
- **Weight:** 25 kgs
- **Housing:** Die-cast Aluminum Alloy

Environmental:

- **Operating temperature:** 0 ~ 40° C
- **Storage temperature:** -20 ~ 60° C
- **Humidity:** 0 ~ 85% RH
- **Shock:** 10 G (11 ms duration)

Dimensions

Unit: mm

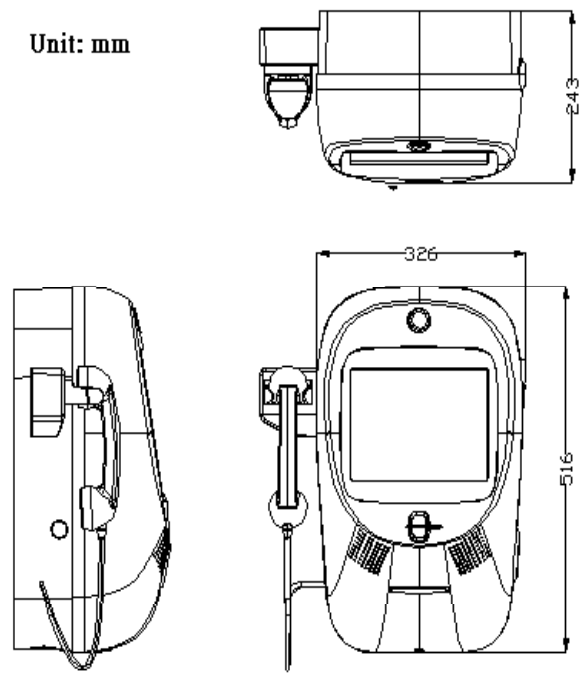

Ordering Information

- **ES-530** Whole system (hardware only)
- **ES-530-TP3** Same as ES-530, except with 3" Thermal printer