

LCM-100
LCD Module
User's Manual

Copyright

This document is copyrighted, 2002, by Advantech Co., Ltd. All rights are reserved. Advantech Co., Ltd. reserves the right to make improvements to the products described in this manual at any time without notice.

No part of this manual may be reproduced, copied, translated or transmitted in any form or by any means without the prior written permission of the original manufacturer. Information provided in this manual is intended to be accurate and reliable. However, the original manufacturer assumes no responsibility for its use, nor for any infringements upon the rights of third parties that may result from its use.

Part No.
1st Edition Printed in Taiwan
August 2002

Product Warranty

Advantech warrants to you, the original purchaser, that each of its products will be free from defects in materials and workmanship for one year from the date of purchase.

This warranty does not apply to any products which have been repaired or altered by persons other than repair personnel authorized by Advantech, or which have been subject to misuse, abuse, accident or improper installation. Advantech assumes no liability under the terms of this warranty as a consequence of such events.

Because of Advantech's high quality-control standards and rigorous testing, most of our customers never need to use our repair service. If an Advantech product is defective, it will be repaired or replaced at no charge during the warranty period. For out-of-warranty repairs, you will be billed according to the cost of replacement materials, service time and freight. Please consult your dealer for more details.

If you think you have a defective product, follow these steps:

1. Collect all the information about the problem encountered. For example, CPU speed, Advantech products used, other hardware and software used, etc. Note anything abnormal and list any on-screen messages you get when the problem occurs.
2. Call your dealer and describe the problem. Please have your manual, product, and any helpful information readily available.
3. If your product is diagnosed as defective, obtain an RMA (return merchandise authorization) number from your dealer. This

allows us to process your return more quickly.

4. Carefully pack the defective product, a fully completed Repair and Replacement Order Card and a photocopy proof of purchase date (such as your sales receipt) in a shippable container. A product returned without proof of the purchase date is not eligible for warranty service.
5. Write the RMA number visibly on the outside of the package and ship it prepaid to your dealer.

On-line Technical Support

For technical support and service, please visit our support website at:

<http://www.advantech.com/support>

Contents

CHAPTER 1	GENERAL INFORMATION	2
	1.2 INTRODUCTION	2
	1.2 PACKING LIST	3
CHAPTER 2	HARDWARE INSTALLATION	6
CHAPTER 3	DEMO TOOL	8
CHAPTER 4	OPERATION EXAMPLES	10
CHAPTER 5	OPERATION PROCEDURE	14

CHAPTER
1

General Information

Chapter 1 General Information

1.1 - Introduction

The major purpose of this module is to provide an easier man-machine interface for those computing systems in which applications friendly operation is a “must”. In traditional computing system design, proprietary keypad and LCD display interfaces are implemented and these interfaces are usually different from system to system. The design goals of this interface are:

- A. A single interface fore both LCD display and keypad is required.
- B. This interface should be available in every computing system
- C. The communication implementation should be OS independent.

Our solution is to use “Serial port” as the interface for both LCD display and keypad. A simple protocol is further defined so that applications can directly communicate with this module no matter what the operating system is.

There are only two connectors in this module, as shown in Fig 1; power connector and serial port connector.

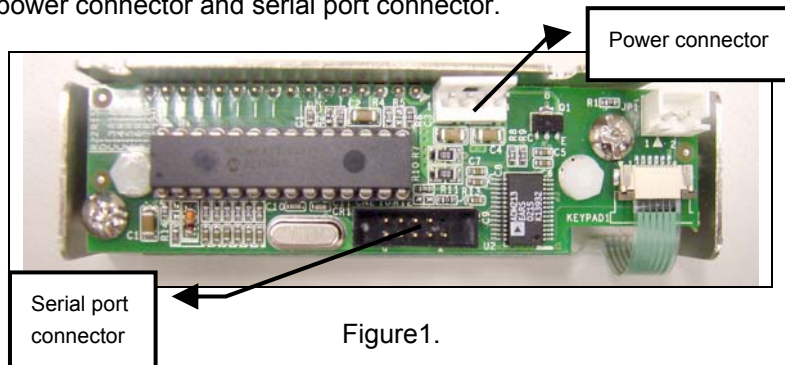

Figure1.

The power source into this module is 5volt only. There are only three pins being used in the serial port interface:

Pin 2: TxD
Pin 3: RxD
Pin 5: Ground

In another words, this serial port is defined as DCE, therefore, we can use straight-through cable to connect it to serial port of most computers because they are defined as DTE.

1.2 - Packing List

You should find the items listed below in the server package. If anything is missing or damaged, please consult with your vendor for resolution.

- 1 LCM-100
- 1 CD Title-Driver Bank
- LCM-100 User's Manual in Driver Bank
- Warrant Card

Technical Support and Sales Assistance

If you have any technical questions about the LCM-100 series products, please visit our support website at <http://www.advantech.com.tw/support>

For more information about Advantech products and sales information, please visit: <http://www.advantech.com>.

CHAPTER
2

Hardware Installation

Chapter 2 Hardware Installation

The installation steps are:

- A. Connect the power cable to the power connector of this module.

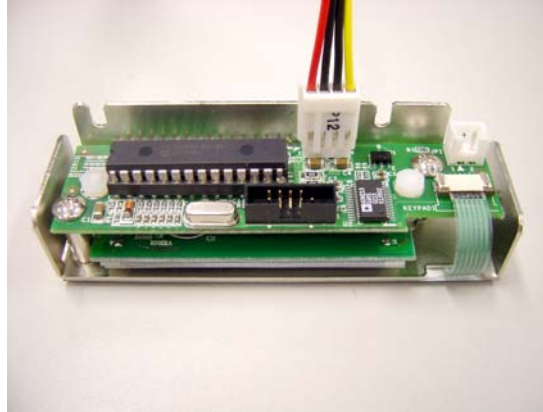

Figure2.

- B. Connect the straight-through cable between serial port of this module and computer.

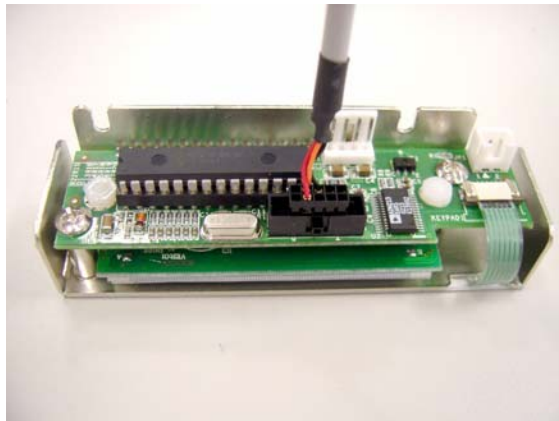

Figure3.

CHAPTER
3

Demo Tool

Chapter 3 Demo Tool

It is a tool for DOS and can be run in Windows environment as well. There are two areas in this Demo/testing tool. The upper area is for editing / sending command / data, as figure 4 shows. The upper area consists of a couple of pages; every page can store up to ten command / data strings. The first byte of every command / data string specifies the length of this string. The second byte and the rest are the content to be sent out and are entered in Hexadecimal format. Detailed function of the tool will be shown after pressing "ALT + F1" keys. To exit the demo tool program, "ALT+ X" can be pressed.

```
Copyright (C) 2001-02-21 TOPPOINT CORP.
BAUD=9600   DATABIT=8  STOPBIT=1  PARITY=NONE  PORT=COM1  2002-09-03  16:36:01
F1 = 00 00 00 00 00 00 00 00 00 00 00 00 00 00 00 00 00 00 00 00 00 00 00 00
F2 = 00 00 00 00 00 00 00 00 00 00 00 00 00 00 00 00 00 00 00 00 00 00 00 00
F3 = 00 00 00 00 00 00 00 00 00 00 00 00 00 00 00 00 00 00 00 00 00 00 00 00
F4 = 00 00 00 00 00 00 00 00 00 00 00 00 00 00 00 00 00 00 00 00 00 00 00 00
F5 = 00 00 00 00 00 00 00 00 00 00 00 00 00 00 00 00 00 00 00 00 00 00 00 00
F6 = 00 00 00 00 00 00 00 00 00 00 00 00 00 00 00 00 00 00 00 00 00 00 00 00
F7 = 00 00 00 00 00 00 00 00 00 00 00 00 00 00 00 00 00 00 00 00 00 00 00 00
F8 = 00 00 00 00 00 00 00 00 00 00 00 00 00 00 00 00 00 00 00 00 00 00 00 00
F9 = 00 00 00 00 00 00 00 00 00 00 00 00 00 00 00 00 00 00 00 00 00 00 00 00
F10= 00 00 00 00 00 00 00 00 00 00 00 00 00 00 00 00 00 00 00 00 00 00 00 00
Press ALT-F1 for help  CC232.EXE Created by Cheng  RUN MONIT  Page 0
```

Figure 4.

CHAPTER

4

Operation Examples

Chapter 4 Operation Examples

These pages of examples are stored as default data of this demo tool. The stored contents are as following:

A. The first page (page 0)

- F1: ASCII code of string "CD"
- F2: Command string to shift the string to right hand side for 3 characters
- F3: Command string to shift the string to right hand side for 3 characters.
- F4: Command string to shift the string to right hand side for 3 characters.
- F5: Command string to request the key-pad status. A response command will be showed after this request command.
- F6: Command string to shift the string to left hand side for 3 characters.
- F7: Command to position the cursor to the bottom line, shift the string to right hand side for 2 characters and ASCII code of string "abcd".
- F8: command string to shift the string to left hand side for 3 characters.
- F9: Command string to request the key-pad status.
- F10: Command to clear screen.

B. The first page (page 1)

- F1: ASCII code of character "A".
- F2: ASCII code of character "L".
- F3: ASCII code of character "b".
- F4: Command string to request the key-pad status. A response command will be shown after this request command.
- F5: Clear screen command.
- F6: Command to position the cursor at the beginning of the second column.
- F7: Command to position the cursor at the beginning of the first

column.

F8: ASCII code of string "ABCDEFGHIJ"

F9: Command to scroll the displayed string to left hand side for one character.

F10: Command to scroll the displayed string to right hand side for one character.

C. The second page (page 2)

F1: Command to position the cursor to the upper and left hand side Conner.

F2: Command to hide displayed string

F3: Command to hide cursor and show hidden string

F4: Command to blink block cursor

F5: Command to show underline

F6: Command to move the cursor to left hand side for one character

F7: Command to move the cursor to right side for one character

F8: ASCII code of character "B"

F9: ASCII code of character "C"

F10: ASCII code of character "3"

CHAPTER
5

Operating procedure

string in displaying area. "Page 0" is a demo page to show:

1. Display the string and move it back / forth and up/ down
2. A loop to interrogate the key pressing status

User can press "Alt" + "F10" so that it will loop between F1 and F10. "Alt" + "0" can be pressed to stop the looping. "Page 1" and "Page 2" are a list of strings to send out data and major commands.

LCM-100 Command

LCM-100 is an intelligent device which will display those data received from RS232 port and reply key pressing status to polling command from RS232 port. There are command and data from RS232 port. To distinguish between data and commands, the LCD/key-pad Module recognizes a command prefix, 254 (Hex 0FE). The byte following "254" will be processed as a command. For example, to clear the screen, send the command prefix (254) followed by the LCD clear-screen code (1). The valid data range is as following table shows.

Valid data range	Displayed characters
0 ~ 7	Customized icon 0~7
48 ~ 57 (30 ~ 39 Hex)	0 ~ 9
65 ~ 90 (41 ~ 5A Hex)	A ~ Z
97 ~ 122 (61 ~ 7A Hex)	A ~ z
Other ASCII characters	{ }, / + - []etc.

To get the key pressing status, a "read key" command can be issued to this module which will check the key-pressing status and reply accordingly. The following are the command and corresponding Decimal/Hex value:

Functions/commands	Decimal/Hex	Remark
Clear screen	1/01	
Home cursor	2/02	
Blank display (retaining data)	8/08	
Hide cursor & display blanked characters	12/0C	
Turn on (blinking block cursor)	13/0D	
Show underline cursor	14/0E	
Move cursor 1 character left	16/10	
Move cursor 1 character right	20/14	
Scroll 1 character left	24/18	

Scroll 1 character right	28/1C	
Set display address (position the cursor) location	128(Hex080) + Location	Note 1
Set character-generator address	64(Hex 040) + address	Note 2

The LCD/key-pad module will check the status of every key and reply with status command accordingly. The replied message from LCD/key-pad module consists of a header and a status byte. The header byte is 253 (Hex0FD). The high nibble (with the most significant bit) of the status byte is “4” or “5” and the low nibble (with the least significant bit) of the status byte is used to indicate key pressing status of the key-pad module. There are five keys in this module- upper arrow, down arrow, left arrow, right arrow, enter (ENT), The relationship between the function key, corresponding status bit, and status byte is as following table.

Function key	Corresponding status bit	Status byte
Up arrow	(0100 0001)	41 (H)
Down arrow	(0100 0010)	42 (H)
Left arrow	(0100 0100)	44 (H)
Right arrow	(0100 1000)	48 (H)
Enter	(0101 0000)	50 (H)

More than one key can be pressed at the same time so that there may be more than one “1”s in the low nibble of status byte. For example, if Up and Down arrow keys are pressed at the same time while ” ready key” command being received, the replied status will be Hex043”.

Note 1:

This command can be used to place the cursor at any location. The corresponding address for each character on the screen is as following:

For 16X2 Display Address

Character	1	2	3	4	5	6	7	8	9	10	11	12	13	14	15	16
Location	00	01	02	03	04	05	06	07	08	09	0A	0B	0C	0D	0E	0F
Address	40	41	42	43	44	45	46	47	48	49	4A	4B	4C	4D	4E	4F

The address of characters at the same row are continuous, so moving cursor commands can be applied to shift the cursor position back and forth. However, the address of characters between upper and lower

row are discontinuous. To change cursor position between upper row and lower row, this command will be applied.

Note 2:

This command can be used to create customized icon. The starting address is 64 and every character will take 8 bytes to create a 5 (width) x 7 (height) resolution picture, as shown in following:

CG RAM MAPPING

CG RAM Address						Character Pattern (CG RAM data)								
5	4	3	2	1	0	7	6	5	4	3	2	1	0	
High			Low			High			Low					
0	0	0	0	0	0	*	*	*	0	1	1	0	0	← Character Pattern
			0	0	1				1	0	0	1	0	
			0	1	0				0	0	1	0	0	
			0	1	1				0	1	0	0	0	
			1	0	0				1	1	1	1	0	
			0	0	0				0	0	0	0	0	
			0	0	0				0	0	0	0	0	
			1	1	1				0	0	0	0	0	
0	0	1	0	0	0	*	*	*	1	1	1	1	1	← Character Pattern
			0	0	1				1	0	0	0	1	
			0	1	0				1	0	1	0	1	
			0	1	1				1	1	0	1	1	
			1	0	0				1	1	0	1	0	
			1	0	1				0	0	0	1	1	
			1	1	0				1	1	1	1	1	
			0	0	0				0	0	0	0	0	
.	
1	1	1	0	0	0	*	*	*	1	1	1	1	1	← Character Pattern
			0	0	1				1	0	0	0	1	
			0	1	0				1	1	1	0	1	
			0	1	1				1	1	0	0	1	
			1	0	0				1	1	0	1	1	
			1	0	1				0	0	0	1	1	
			1	1	0				1	1	1	1	1	
			0	0	0				0	0	0	0	0	

To show the customized icon, just send the data between "0" to "7" to this module. For example, this module will display the customized icon at location 64 to 71 upon receiving data "0"; it will display the customized icon at location 72 to 79 upon receiving data "1".

There is a built-in watch dog timer in the module. This module will

reset itself and send out “reset packet” (0FDH, 0EH) there after.

The input must be a standard RS232 or inverted TTL signal. The RS232 setup is:

Baud rate: 2400 bps

Parity: None

Data bits: 8

Stop bit: 1

The following are default setup after LCD module be initiated:

1. 2-line display mode; every character is 5 x 8 dots.
2. Display on; cursor off; cursor blink off.
3. Display will be cleared
4. Shift right for entry mode.
5. Set address counter to “00” (cursor position to 0)
6. In entry mode